

## Adjustable Accurate Reference Source

## TL431

## ■ Features

- The output voltage can be adjusted to 36V.
- Low dynamic output impedance, its typical value is  $0.2\Omega$ .
- Trapping current capability is 1 to 100mA.
- The typical value of the equivalent temperature factor in the whole temperature scope is  $50 \text{ ppm}/^\circ\text{C}$ .
- The effective temperature compensation in the working Range of full temperature.
- Low output noise voltage.
- Fast on-state response.

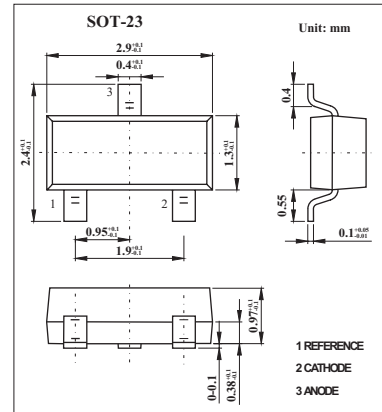

## ■ Internal Block Diagram

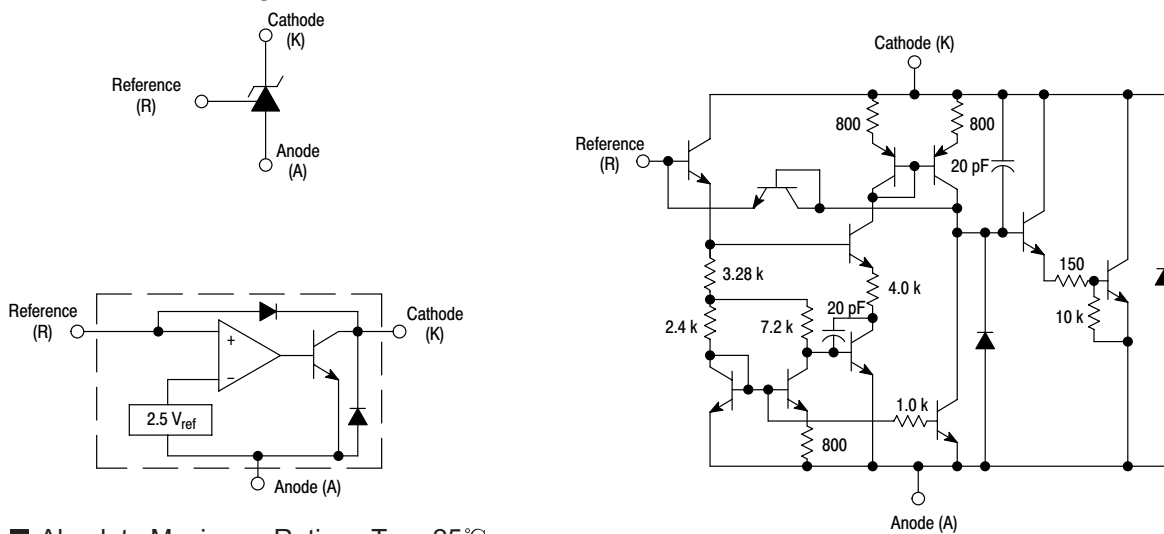
■ Absolute Maximum Ratings  $T_a = 25^\circ\text{C}$ 

Parameter	Symbol	Rating	Unit
Cathode Voltage	$V_{KA}$	37	V
Cathode Current Range (Continuous)	$I_{KA}$	-100 +150	mA
Reference Input Current Range	$I_{ref}$	0.05 +10	mA
Power Dissipation	$P_D$	350	mW
Operating Temperature	$T_{opr}$	0-70	$^\circ\text{C}$
Storage Temperature Range	$T_{stg}$	-65 to +150	$^\circ\text{C}$

## TL431

## ■ Electrical Characteristics Ta = 25°C

Parameter	Symbol	Test conditions	Min	Typ	Max	Unit
Reference Input Voltage	Vref	V <sub>KA</sub> =V <sub>REF</sub> , I <sub>KA</sub> =10mA	2.450	2.5	2.550	V
Deviation of reference Input Voltage Over temperature *	$\Delta V_{ref}/\Delta T$	V <sub>KA</sub> =V <sub>REF</sub> , I <sub>KA</sub> =10mA, T <sub>min</sub> ≤T <sub>a</sub> ≤T <sub>max</sub>		4.5	17	mV
Ratio Of Change in Reference Input Voltage to the change in Cathode Voltage	$\Delta V_{ref}/\Delta V_{KA}$	I <sub>KA</sub> =10mA $\Delta V_{KA} = 10V \sim V_{REF}$ I <sub>KA</sub> =10mA $\Delta V_{KA} = 36V \sim 10V$		-1.0 -0.5	-2.7 -2.0	mV/V
Reference input Current	Iref	I <sub>KA</sub> =10mA, R <sub>1</sub> =10KΩ R <sub>2</sub> =∞		1.5	4	μA
Deviation Of Reference Input Current Over Full Temperature Range	$\Delta I_{ref}/\Delta T$	I <sub>KA</sub> = 10mA, R <sub>1</sub> =10KΩ R <sub>2</sub> =∞ T <sub>A</sub> =full Temperature		0.4	1.2	μA
Minimum cathode current for regulation	I <sub>KA</sub> (min)	V <sub>KA</sub> = V <sub>REF</sub>		0.45	1.0	mA
Off-state cathode Current	I <sub>KA</sub> (OFF)	V <sub>KA</sub> =36V, V <sub>REF</sub> =0		0.05	1.0	μA
Dynamic impedance	Z <sub>KA</sub>	V <sub>KA</sub> =V <sub>REF</sub> , I <sub>KA</sub> =1 to 100mA f≤1.0KHz		0.15	0.5	Ω

\*.T<sub>MIN</sub>=0°C T<sub>MAX</sub>=+70°C

## ■ Marking

Marking	431
---------	-----

## ■ Classification of Vref

Rank	0.5%	1%	2%
Range	2.487-2.512	2.475-2.525	2.45-2.55

## ■ Test Circuits

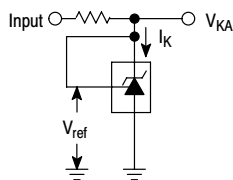
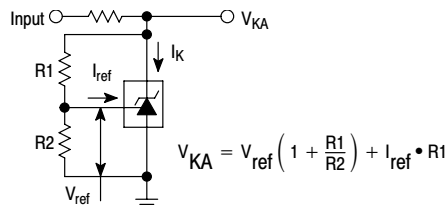
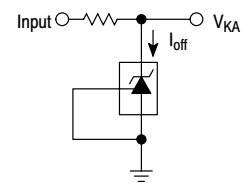
Figure 1. Test Circuit for V<sub>KA</sub> = V<sub>ref</sub>Figure 2. Test Circuit for V<sub>KA</sub> > V<sub>ref</sub>Figure 3. Test Circuit for I<sub>off</sub>

TL431

■ Typical Characteristics

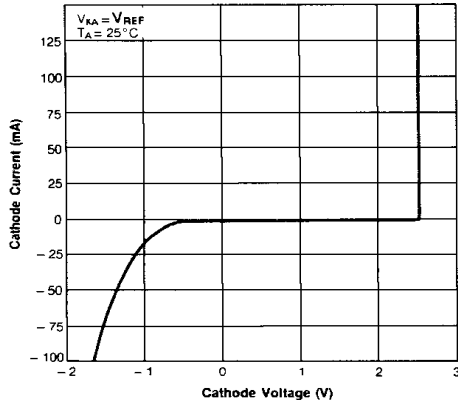

Figure 1. Cathode Current vs. Cathode Voltage

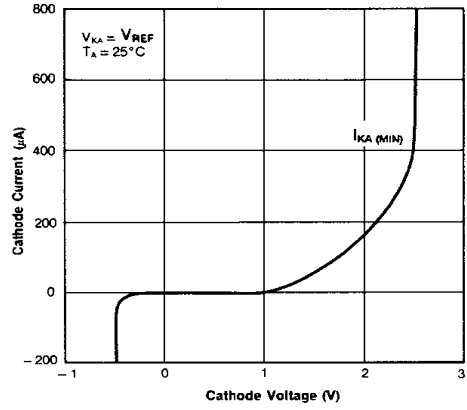

Figure 2. Cathode Current vs. Cathode Voltage

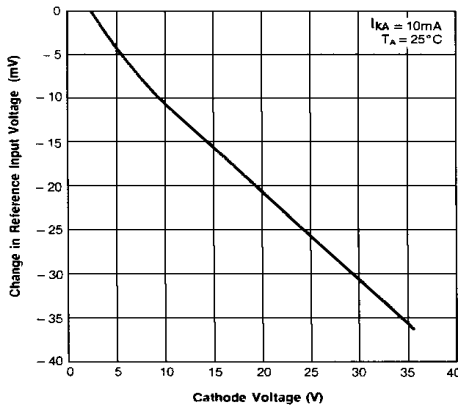

Figure 3. Change In Reference Input Voltage vs. Cathode Voltage

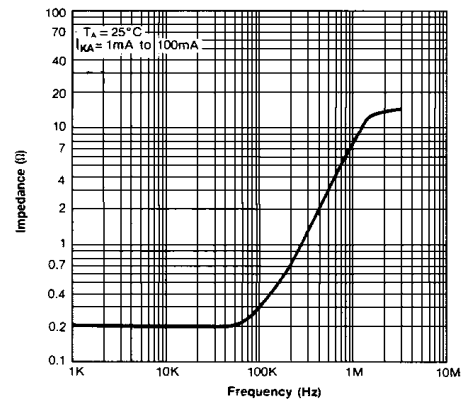

Figure 4. Dynamic Impedance Frequency

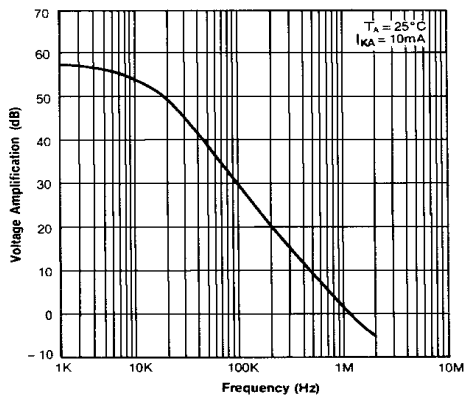

Figure 5. Small Signal Voltage Amplification vs. Frequency

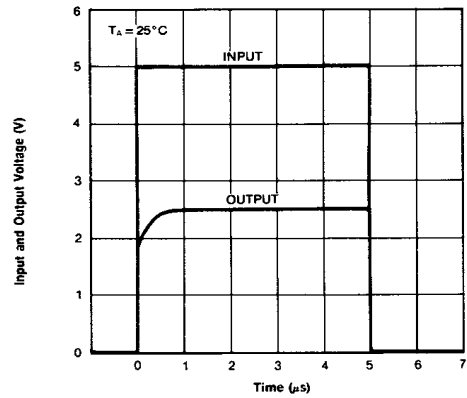

Figure 6. Pulse Response

## X-ON Electronics

Largest Supplier of Electrical and Electronic Components

*Click to view similar products for [Voltage References](#) category:*

*Click to view products by [KEXIN](#) manufacturer:*

Other Similar products are found below :

[622664A](#) [636116E](#) [748389C](#) [AS431ARTR-E1](#) [NCP431BCSNT1G](#) [NCP432BCSNT1G](#) [NCV431BSNT1G](#) [AP4313UKTR-G1](#)  
[TL1431AIYDT](#) [AZ431BR-ATRE1](#) [622668D](#) [NCP432BVSNT1G](#) [5962-8686103XC](#) [NCV431BVDMR2G](#) [AP4306BUKTR-G1](#)  
[SC431BVSNT1G](#) [MAX6023EBT30+T](#) [NCV431ASNT1G](#) [LM4040CEM3-5.0/V+T](#) [LT1460KCS3-3#TRM](#) [LT1460KCS3-3.3#TRM](#)  
[LT1019AIS8-2.5](#) [LT6660KCDC-10#TRMPBF](#) [LTC6652BHLS8-5#PBF](#) [LTC6652AHLS8-4.096#PBF](#) [LTC6655BHLS8-4.096#PBF](#)  
[LT6660HCDC-5#TRMPBF](#) [LM336Z-2.5#PBF](#) [LT1021BMH-10](#) [SC431ILPRAG](#) [TLVH431MIL3T](#) [MAX6023EBT21+T](#) [AP432AQG-7](#)  
[ADR4540CRZ](#) [LM4040B25QFTA](#) [TS3325AQPR](#) [REF102AU/2K5](#) [TL4050B25QDBZR](#) [TL4051C12QDCKR](#) [TL431ACZ](#) [KA431SLMF2TF](#)  
[KA431SMF2TF](#) [KA431SMFTF](#) [LM385BXZ/NOPB](#) [LM4040QCEM3-3.0/NOPB](#) [LM4041C12ILPR](#) [LM4050AEM3X-5.0/NOPB](#)  
[LM4050AIM3X-5.0/NOPB](#) [LM4120AIM5-2.5/NOP](#) [LM431SCCMFX](#)