

DO NOT SCALE FROM THIS PRINT

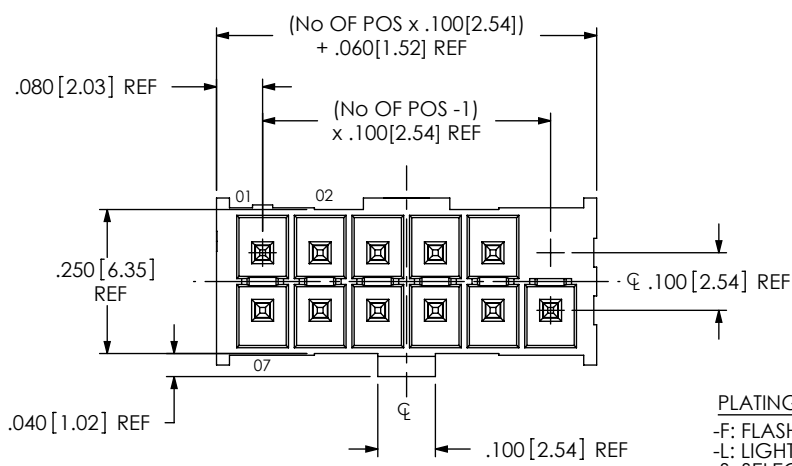
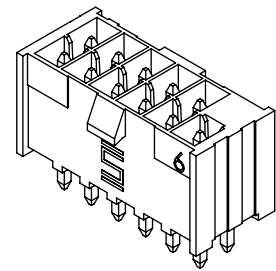
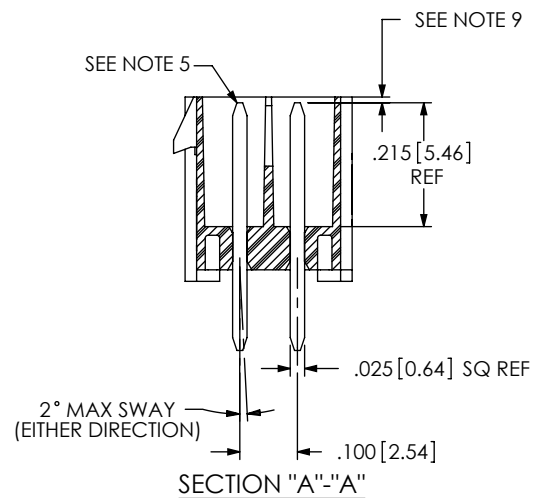
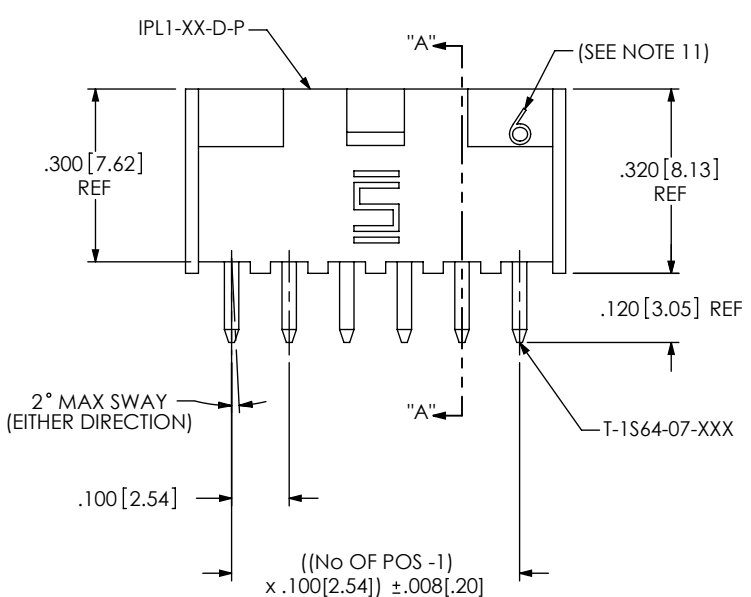

FIG 1  
IPL1-106-01-XXX-D-P SHOWN

IPL1-1XX-XX-XXX-D-XX-X

- No OF POSITIONS  
-02 THRU -25  
(PER ROW)
- LEAD STYLE  
-01: THROUGH HOLE  
(USE T-1S64-XX-XX)  
-02: SURFACE MOUNT  
(SEE FIG 2, SHT 2)  
(USE T-1S64-XX-XX)
- PLATING SPECIFICATION  
-F: FLASH SELECTIVE (USE T-1S64-XX-F)  
-L: LIGHT SELECTIVE (USE T-1S64-XX-L)  
-S: SELECTIVE (USE T-1S64-XX-S)  
-H: HEAVY GOLD (T-1S64-XX-H)  
-FM: FLASH SELECTIVE/MATTE TIN TAILS (USE T-1S64-XX-F)  
-LM: LIGHT SELECTIVE/MATTE TIN TAILS (USE T-1S64-XX-L)  
-SM: SELECTIVE/MATTE TIN TAILS (USE T-1S64-XX-S)  
-STL: SELECTIVE/TIN/LEAD TAILS (USE T-1S64-XX-STL)
- OPTION  
-P: POLARIZATION (SEE FIG 1)  
(USE IPL1-XX-D-P)  
(NOT AVAILABLE W/ -K, OPTIONS)  
-K: KEYED POLARIZATION  
(USE IPL1-XX-D-K)  
(SEE FIG 5, SHEET 3)  
(NOT AVAILABLE W/ -P, OPTIONS)  
-G: GUIDE POSTS (SEE FIG 6 & 7, SHEET 3)  
(USE IPL1-XX-D-GP)  
(NOT AVAILABLE W/-P, -K OPTIONS)
- (LEAVE BLANK FOR NO POLARIZATION  
(SEE FIG 4, SHEET 3), SAMTEC WILL ONLY SUPPORT  
EXISTING BUSINESS AS OF REV U)
- OPTION  
-RA: RIGHT ANGLE (SEE FIG. 3, SHT 2)  
(AVAILABLE WITH -01 LEAD STYLE ONLY)
- ROW SPECIFICATION  
-D: DOUBLE (USE IPL1-XX-D)



NOTES:

1.  $\text{\textcircled{C}}$  REPRESENTS A CRITICAL DIMENSION.
2. NOTE DELETED.
3. MINIMUM TERMINAL RETENTION: 1 LB.
4. PARTS TO BE MOLDED TO POSITION.
5. POST MUST BE WITHIN .005[.13] OF EACH OTHER.
6. ALL PIN TO PIN DIMENSIONS TO BE MEASURED FROM TIP TO TIP.
7. NOTE DELETED.
8. DIMENSION TO BE MEASURED AT BEND.
9. TIP TO BE FLUSH TO .015 BELOW TOP OF SHROUD.
10. BOTH ROWS TO BE SYMMETRIC WITHIN .010[0.25].
11. THIS NUMBER REPRESENTS THE NUMBER OF POSITIONS PER ROW ONLY AND IS NOT INTENDED TO BE USED IN POSITION NUMBERING.
12. 1 OR 2 GATE PADS TO BE PRESENT AT VENDOR DISCRETION.

LEAD STYLE	OPTION	TERMINAL 1	OAL REF	TERMINAL 2	OAL REF
-01	NONE	T-1S64-07-X	.430[10.92]	N/A	N/A
-01	-RA	T-1S64-09-X	.530[13.46]	T-1S64-10-X	.730[18.54]
-02	NONE	T-1S64-08-X	.445[11.30]	N/A	N/A

<p>UNLESS OTHERWISE SPECIFIED, DIMENSIONS ARE IN INCHES. TOLERANCES ARE: DECIMALS ANGLES .XX: ±.01 [.3] ± 2° .XXX: ±.005 [.13] .XXXX: ±.0020 [.051]</p>	<p>PROPRIETARY NOTE THIS DOCUMENT CONTAINS INFORMATION CONFIDENTIAL AND PROPRIETARY TO SAMTEC, INC. AND SHALL NOT BE REPRODUCED OR TRANSFERRED TO OTHER DOCUMENTS OR DISCLOSED TO OTHERS OR USED FOR ANY PURPOSE OTHER THAN THAT WHICH IT WAS OBTAINED WITHOUT THE EXPRESSED WRITTEN CONSENT OF SAMTEC, INC.</p>	<p>520 PARK EAST BLVD, NEW ALBANY, IN 47150 PHONE: 812-944-6733 FAX: 812-948-5047 e-Mail: info@SAMTEC.com code 55322</p>

FIG 2  
IPL1-106-02-XXX-D-P SHOWN  
[DIFFERENT AS SHOWN, OTHERWISE SAME AS FIG 1]

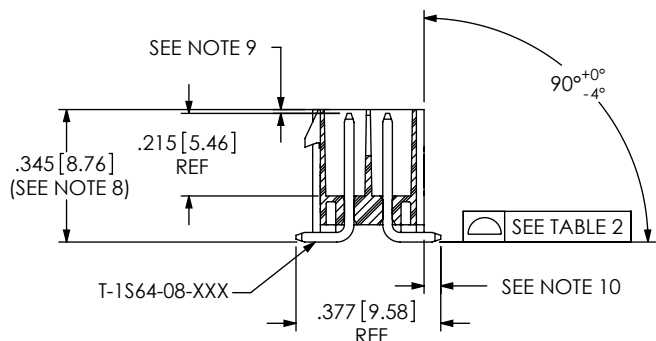
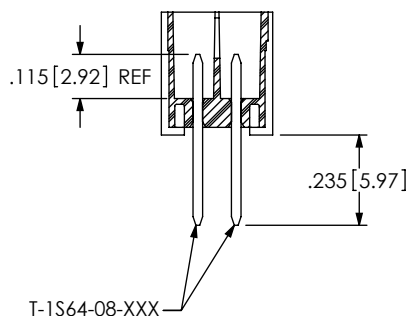
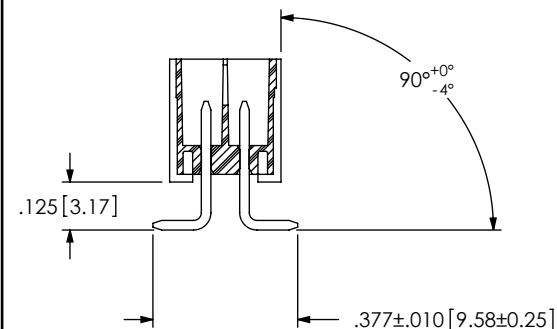

TABLE 2	
No OF POS.	COPLANARITY
-02 THRU -05	.004[.10]
-06 THRU -10	.005[.13]
-11 THRU -25	.006[.15]

-02: SURFACE MOUNT INPROCESS 1



-02: SURFACE MOUNT INPROCESS 2



PACKAGING VIEWS  
(ASSEMBLIES TO HAVE POSITION #1 LOADED IN THE SAME DIRECTION AS ARROW ON TUBE, EXCEPT WITH -RA OPTION)

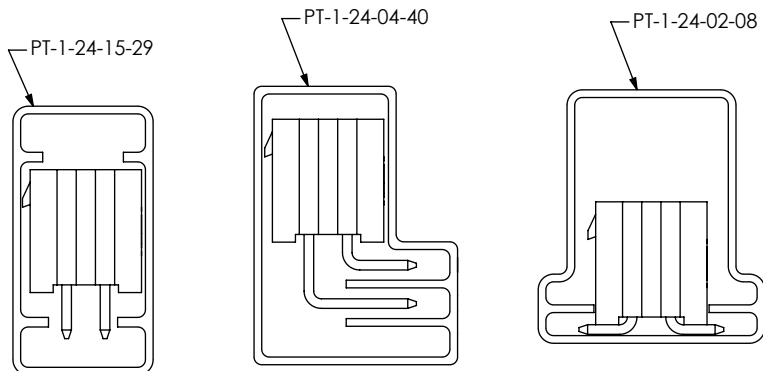

PACKAGING TABLE			
LEAD STYLE	OPTION	PACKAGING TUBE	PLUG
-01	NONE	PT-1-24-15-29	TP-07
-01	-RA	PT-1-24-04-40	TP-07
-02	NONE	PT-1-24-02-08	TP-13

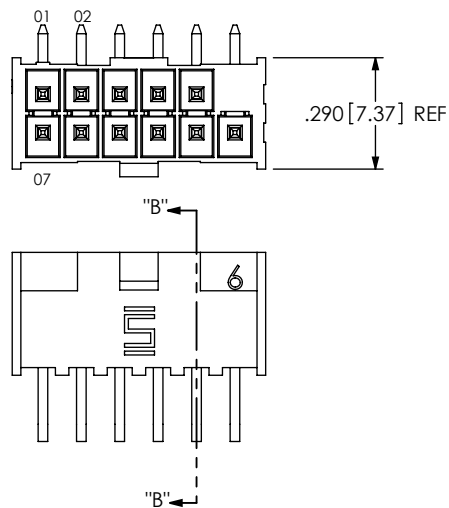
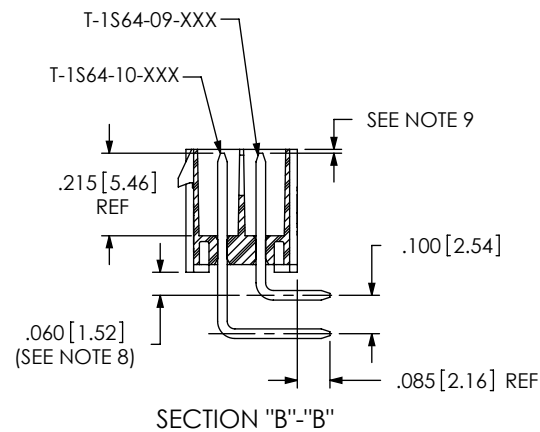

FIG 3  
IPL1-106-01-XXX-D-RA-P SHOWN  
(DIFFERENT AS SHOWN, OTHERWISE SAME AS FIG 1)



F:\DWG\MISC\MKTG\IPL1-1XX-XX-XXX-D-XX-X-MKT.SLDDRW

**PROPRIETARY NOTE**  
THIS DOCUMENT CONTAINS INFORMATION CONFIDENTIAL AND PROPRIETARY TO SAMTEC, INC. AND SHALL NOT BE REPRODUCED OR DISCLOSED TO OTHERS OR USED FOR ANY PURPOSE OTHER THAN THAT WHICH IT WAS OBTAINED WITHOUT THE EXPRESSED WRITTEN CONSENT OF SAMTEC, INC.

DO NOT SCALE DRAWING

SHEET SCALE: 2:1

520 PARK EAST BLVD, NEW ALBANY, IN 47150  
PHONE: 812-944-6733 FAX: 812-948-5047  
e-Mail info@SAMTEC.com code 55322

DESCRIPTION:  
.100[2.54] DOUBLE ROW TERMINAL ASSEMBLY

DWG. NO.  
**IPL1-1XX-XX-XXX-D-XX-X**

BY: KEVIN B 03/11/02 SHEET 2 OF 3

REVISION AD

-RA: INPROCESS 1

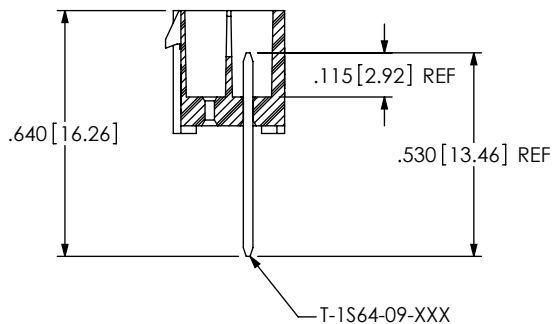

-RA: INPROCESS 2

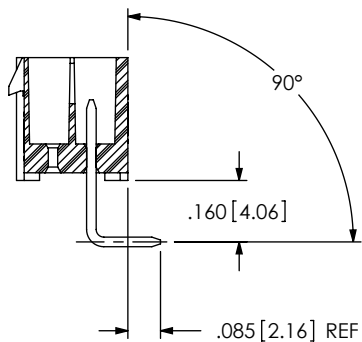

-RA: INPROCESS 3

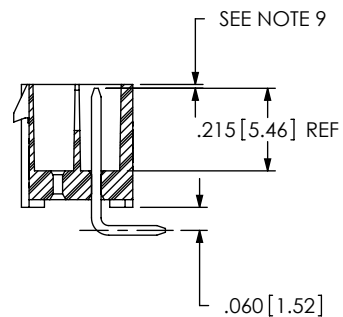

-RA: INPROCESS 4

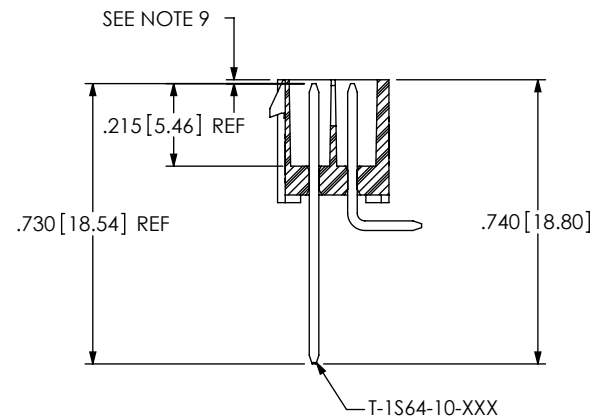

FIG 4  
(IPL1-106-0T-XXX-D SHOWN)  
(DIFFERENT AS SHOWN,  
OTHERWISE SAME AS FIG 1)

**SAMTEC WILL ONLY SUPPORT  
EXISTING BUSINESS AS OF REV. U)**

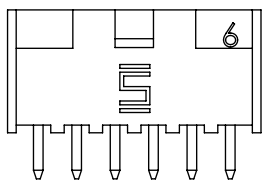
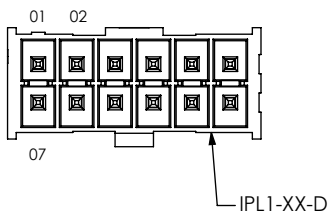

FIG 5  
(IPL1-106-01-XXX-D-K SHOWN)  
(DIFFERENT AS SHOWN, OTHERWISE SAME AS FIG 4)

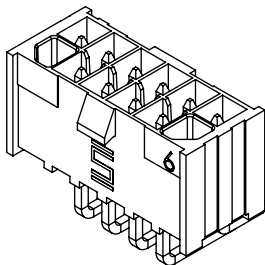
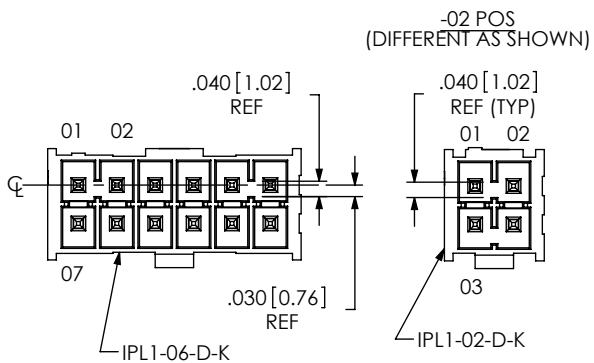

FIG 6  
(IPL1-106-01-XXX-D-RA-G SHOWN)  
(DIFFERENT AS SHOWN, OTHERWISE SAME AS FIG 3)

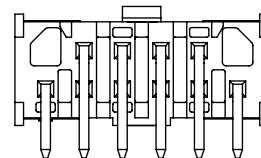
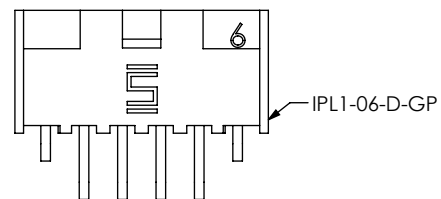
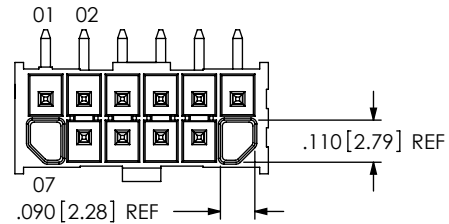
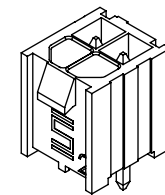
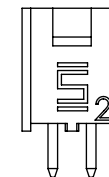
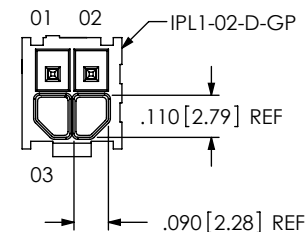

FIG 7  
(IPL1-102-01-XXX-D-G SHOWN)  
(DIFFERENT AS SHOWN,  
OTHERWISE SAME AS FIG 1)



PROPRIETARY NOTE

THIS DOCUMENT CONTAINS INFORMATION  
CONFIDENTIAL AND PROPRIETARY TO  
SAMTEC, INC. AND SHALL NOT BE REPRODUCED  
OR TRANSFERRED TO OTHER DOCUMENTS OR  
DISCLOSED TO OTHERS OR USED FOR ANY  
PURPOSE OTHER THAN THAT WHICH IT WAS  
OBTAINED WITHOUT THE EXPRESSED WRITTEN  
CONSENT OF SAMTEC, INC.

DO NOT SCALE DRAWING

SHEET SCALE: 2:1

**samtec**

520 PARK EAST BLVD. NEW ALBANY, IN 47150  
PHONE: 812-944-6733 FAX: 812-948-5047  
e-Mail: info@SAMTEC.com code 55322

DESCRIPTION:  
.100[2.54] DOUBLE ROW TERMINAL ASSEMBLY

DWG. NO.  
**IPL1-1XX-XX-XXX-D-XX-X**

BY: KEVIN B 03/11/02 SHEET 3 OF 3

## X-ON Electronics

Largest Supplier of Electrical and Electronic Components

*Click to view similar products for [samtec](#) manufacturer:*

Other Similar products are found below :

[ESQT-130-03-M-Q-368](#) [ESQT-135-03-F-D-380](#) [FTSH-105-01-L-D-K](#) [FTSH-111-01-L-DV](#) [QTE-060-01-L-D-A](#) [MSAS-179-ZUGG-18](#)  
[MTSW-103-07-F-S-240](#) [MTSW-125-24-H-D-285](#) [BCS-116-L-S-TE](#) [ERF8-020-05.0-S-DV-K-TR](#) [ERF8-060-05.0-L-DV-K-TR](#) [IDMD-10-T-12.00-A-G-R](#) [IPL1-112-01-L-D-K](#) [SFM-110-02-S-D](#) [SFML-115-01-S-D](#) [SFML-125-01-S-D](#) [SFSDT-15-28-H-04.50-DR-NDS](#) [LSHM-120-02.5-L-DV-A-N-K-TR](#) [SMS-125-02-S-D](#) [ESQ-110-14-G-D](#) [ESQT-125-03-F-D-310](#) [SQW-120-01-F-D-VS-A](#) [SSW-110-02-H-D](#) [CES-150-01-T-D](#) [QFS-052-01-SL-D-RA](#) [QTE-040-04-L-D-A](#) [QTH-020-04-F-D-DP-A-K-TR](#) [QTH-060-01-F-D-A](#) [QTH-090-04-L-D-A](#) [TCSD-10-S-05.00-01-F-N](#) [TFM-110-02-S-D](#) [TFM-115-02-L-DH](#) [TFM-120-12-S-D-LC](#) [TFML-140-02-S-D](#) [TLW-107-05-G-D](#) [TMM-140-03-S-Q](#) [BDL-136-T-E](#) [TSS-132-01-G-S](#) [TST-113-04-S-D-RA](#) [TSW-105-14-F-D](#) [HMTSW-108-22-S-S-400](#) [BSE-040-01-F-D-A](#) [HPF-03-02-T-S](#) [TW-03-06-H-D-400-SM-A](#) [ZW-20-13-H-D-790-150](#) [ERF8-020-01-L-D-RA-L-TR](#) [ERF8-025-05.0-L-DV-TR](#) [ERF8-040-05.0-L-DV-TR](#) [SL-120-T-10](#)  
[SLM-115-01-S-D](#)