

REVISION ET

NOTES:

1.  $\text{\textcircled{C}}$  REPRESENTS A CRITICAL DIMENSION.
2. PARTS MAY BE CUT TO POSITION.
3. MAXIMUM CUT FLASH: .015[0.38]. LOOSE FLASH MUST BE REMOVED.
4. MINIMUM PUSHOUT FORCE: 1.0 LB.
5. MEASURED AT BEND RADIUS, NOT AT END OF PIN.
6. TUBE ONLY -04 THROUGH -50 POSITIONS (SEE TABLE 2).
7. SHEAR TAILS TO DIMENSION SHOWN.
8. MAXIMUM BURR ALLOWANCE: .003 [0.08]
9. GOLD PLATING TO BE ON POST, TIN PLATING TO BE ON TAIL.
10. FILL WITH ALIGNMENT PIN HOLES TO TAIL SIDE.
11. DUE TO THE HIGH AMOUNT OF INSERTION FORCE NEEDED, LOCKING CLIPS ARE NOT COMPATIBLE WITH AUTO PLACEMENT. SAMTEC RECOMMENDS MANUAL PLACEMENT FOR ALL ASSEMBLIES WITH LOCKING CLIPS.
12. VOIDS MAY OR MAY NOT BE PRESENT ON POSITIONS 5 THRU 8 AND CAN BE MIXED WITHIN AN ORDER.
13. ON LEAD STYLES -01 THROUGH -04 THE T-1S15-03 CAN BE SUBSTITUTED FOR T-1S15-14.

DO NOT SCALE FROM THIS PRINT

FTSH-1XX-XX-XXX-DV-XXX

No OF POSITIONS  
-02 THRU -50  
(PER ROW)

LEAD STYLE

- 01: .120 [3.05]
- 02: .075 [1.91]
- 03: .065 [1.65]
- 04: .150 [3.81]
- 05: .170 [4.32]
- 14: .150 [3.81]

(NOT AVAILABLE WITH -SM, FM, LM PLATING OPTIONS)

PLATING SPECIFICATION

- L: 10 $\mu$ " SELECTIVE GOLD IN CONTACT AREA, MATTE TIN ON TAIL
- F: 3 $\mu$ " SELECTIVE GOLD IN CONTACT AREA, MATTE TIN ON TAIL
- S: 30 $\mu$ " SELECTIVE GOLD IN CONTACT AREA, MATTE TIN ON TAIL
- H: 30 $\mu$ " GOLD IN CONTACT AREA, 3 $\mu$ " GOLD ON TAIL
- LM: 10 $\mu$ " SELECTIVE GOLD IN CONTACT AREA, MATTE TIN ON TAIL
- FM: 3 $\mu$ " SELECTIVE GOLD IN CONTACT AREA, MATTE TIN ON TAIL
- SM: 30 $\mu$ " SELECTIVE GOLD IN CONTACT AREA, MATTE TIN ON TAIL
- LTL: 10 $\mu$ " SELECTIVE GOLD IN CONTACT AREA, TIN/LEAD (90/10+/-5%) TAIL
- G: 10 $\mu$ " GOLD IN CONTACT AREA, 3 $\mu$ " GOLD ON TAIL

TAIL OPTION

-DV: DOUBLE VERTICAL  
(USE \*\*FTSH-1XX-XX-XXX-DV FOR ALL OPTIONS EXCEPT -ES, -EJ, -EJM, -EJC, -EC, -EP, -EL, -EPC, -A, THEN USE FTSH-50-D AND BUILD PER PRINT)  
\*\* = SEE FTSHC-1XX-XX-XXX-DX-XX PRINT FOR DETAILS

OPTIONS

- P: PICK & PLACE PAD (4 POS MIN) (SEE FIG 11, SHT 4 & TABLE 5)
- TR: TAPE & REEL PACKAGING
- ES: END SHROUDS (SEE FIG 6, SHT 3) (MOLDED IN 5 POS MIN; -02 & -03 LEAD STYLE ONLY) (SNAP SHROUDS 9 POS MIN; -02 & -03 LEAD STYLE ONLY) (MUST USE FTSH-50-D)
- EJ: EJECTOR SHROUDS: (SEE FIG 4, SHT 2) (10 POS MIN; -01 LEAD STYLE ONLY) (MUST USE FTSH-50-D)
- EJM: EJECTOR SHROUDS WITH MOLDED ALIGNMENT PIN (SEE FIG 5, SHT 2; 10 POS MIN; -01 LEAD STYLE ONLY) (NOT VALID WITH -A OPTION) (MUST USE FTSH-50-D)
- EJC: EJECTOR SHROUDS WITH LOCKING CLIP (SEE FIG 5, SHT 2 & NOTE 11) (10 POS MIN; -01 LEAD STYLE ONLY; NOT VALID WITH -A OPTION) (MUST USE FTSH-50-D)
- EC: LOCKING CLIP (SEE FIG 7, SHT 3 & NOTE 11) (9 POS MIN; -02 & -03 LEAD STYLE ONLY) (MUST USE FTSH-50-D)
- EP: GUIDE POST (SEE FIG 8, SHT 3; 9 POS MIN; -02 & -03 LEAD STYLE ONLY) (USE ONLY WHEN MATING WITH CLP) (MUST USE FTSH-50-D)
- EL: BOARD LOCK (SEE FIG 9, SHT 3) (9 POS MIN; -02 & -03 LEAD STYLE ONLY) (USE ONLY WHEN MATING WITH CLP) (MUST USE FTSH-50-D)
- EPC: GUIDE POST & LOCKING CLIP (SEE FIG 10, SHT 3 & NOTE 11; USE ONLY WHEN MATING WITH CLP) (9 POS MIN; -02 & -03 LEAD STYLE ONLY; NOT VALID WITH -A OPTION) (MUST USE FTSH-50-D)
- A: ALIGNMENT PIN (MOLDED OR STAKED; SEE FIG 3, SHT 2) (MOLDED: 3 POS MIN; STAKED: 6 POS MIN) (SAMTEC DISCRETION ON WHICH -A PIN USED) (MUST USE FTSH-50-D)
- K: KEYING OPTION FOR MATING WITH FFSD (SEE TABLE 3, SHT 2; 05 THRU 25 AVAILABLE AS STANDARD) (POSITION 13, 17, 20 & 25 AVAILABLE WITH -EJ OPTION) (LEAD STYLE -01 ONLY, SEE FIG 2, SHT 2 & NOTE 12) (ALIGNMENT PIN AVAILABLE WITH -K OPTION BUT MUST BE MOLDED) (MUST USE FTSH-XX-CN-XX)
- \*-M: METAL PICK & PLACE PAD (5 POS MIN; USE MPP-22-5) (SEE FIG 12, SHT 4; NOT AVAILABLE WITH -K OPTION)
- \* = NOT ENGINEERING APPROVED

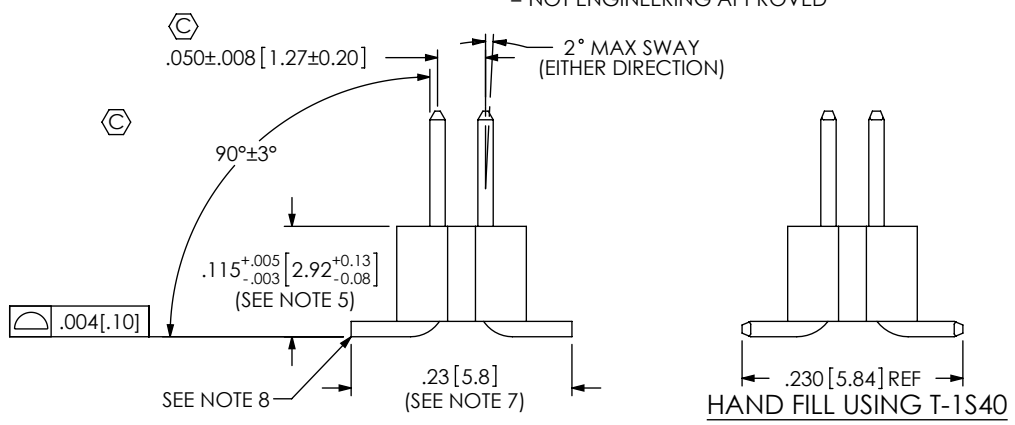
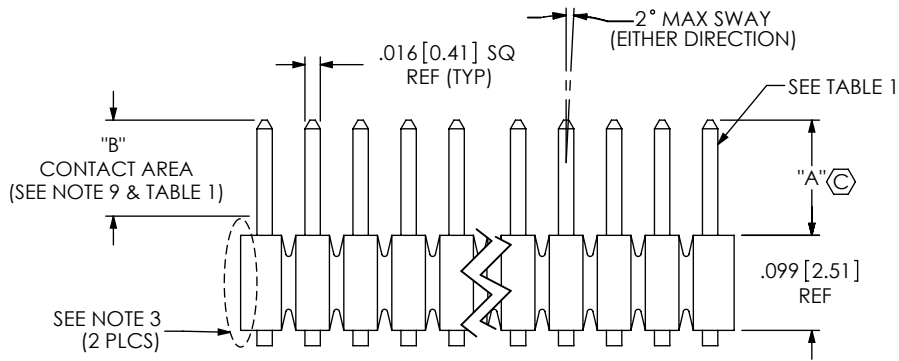
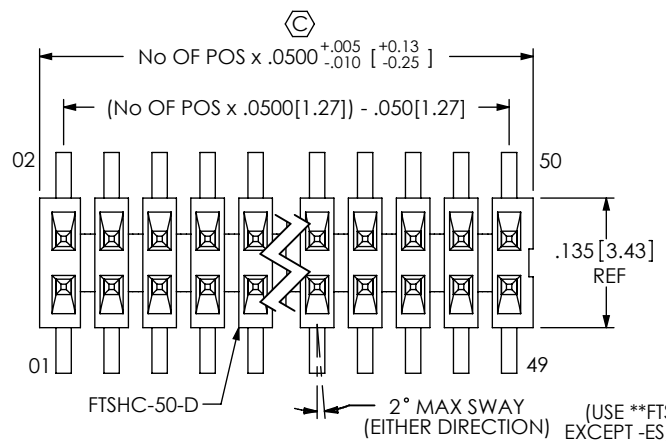

PATENT NUMBERS  
5713755 / 5961339

FIG 1  
FTSH-1XX-XX-XXX-DV SHOWN  
(SEE FTSHC-1XX-XX-XXX-DX-XX PRINT FOR DETAILS)

TABLE 1

LEAD STYLE	"A"	"B" REF	AUTOMATED BKT	HAND FILL	MICRO HEADER
-01	.120 [3.05]	.070 [1.78]	* T-1S15-14-XXX	T-1S40-03-XX-2	T-1S40-03-XX-3
-02	.075 [1.91]	.070 [1.78]	* T-1S15-14-XXX	* T-1S15-14-XXX	NOT AVAILABLE
-03	.065 [1.65]	.070 [1.78]	* T-1S15-14-XXX	* T-1S15-14-XXX	NOT AVAILABLE
-04	.150 [3.81]	.070 [1.78]	* T-1S15-14-XXX	* T-1S15-14-XXX	NOT AVAILABLE
-05	.170 [4.32]	.070 [1.78]	T-1S15-03-XXX	T-1S15-03-XXX	NOT AVAILABLE
* -14	.150 [3.81]	.135 [3.43]	T-1S15-63-XXX	T-1S15-63-XXX	NOT AVAILABLE

\* = SEE NOTE 13

UNLESS OTHERWISE SPECIFIED, DIMENSIONS ARE IN INCHES. TOLERANCES ARE:  
DECIMALS ANGLES  
.XX: ±.01 [.3] 1°  
.XXX: ±.005 [.13]  
.XXXX: ±.0010 [.025]

PROPRIETARY NOTE

THIS DOCUMENT CONTAINS INFORMATION CONFIDENTIAL AND PROPRIETARY TO SAMTEC, INC. AND SHALL NOT BE REPRODUCED OR TRANSFERRED TO OTHER DOCUMENTS OR DISCLOSED TO OTHERS OR USED FOR ANY PURPOSE OTHER THAN THAT WHICH IT WAS OBTAINED WITHOUT THE EXPRESSED WRITTEN CONSENT OF SAMTEC, INC.

MATERIAL: DO NOT SCALE DRAWING SHEET SCALE: 5:1  
INSULATOR: LCP UL 94 VO  
TERMINAL: PHOSPHOR BRONZE

**samtec**  
520 PARK EAST BLVD, NEW ALBANY, IN 47150  
PHONE: 812-944-6733 FAX: 812-948-5047  
e-Mail: info@SAMTEC.com code 53322

DESCRIPTION:  
.050 x .050 CL DOUBLE VERTICAL SMT TERMINAL STRIP

DWG. NO.  
**FTSH-1XX-XX-XXX-DV-XXX**

BY: PURVIS 10/12/1995 SHEET 1 OF 5

REVISION ET

FIG 2

-K OPTION

(LEAD STYLE -01 ONLY)

(DIFFERENT AS SHOWN, OTHERWISE SAME AS FIG 1)

(POSITION 13, 17, 20 & 25 AVAILABLE WITH

-EJ OPTION)

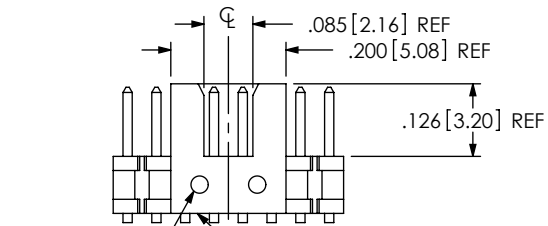
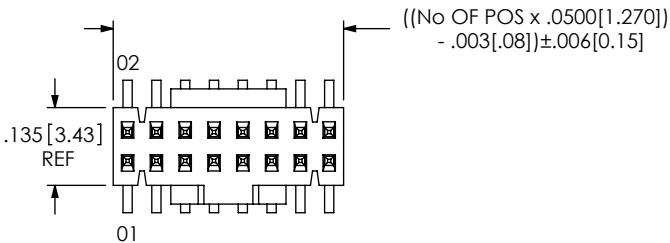

SEE NOTE 12 FTSH-50-CN-XX

TABLE 3		
No OF POS	BODY	No OF PARTS PER FULL STRIP
-05	FTSH-50-CN-05	10
-06	FTSH-50-CN-06	8
-07	FTSH-50-CN-07	7
-08	FTSH-50-CN-08	6
-09	FTSH-50-CN-09	5
-10	FTSH-50-CN-10	5
-11	FTSH-50-CN-11	4
-12	FTSH-50-CN-12	4
-13	FTSH-50-CN-13	3
-14	FTSH-50-CN-14	3
-15	FTSH-50-CN-15	3
-16	FTSH-50-CN-16	3
-17	FTSH-50-CN-17	2
-18	FTSH-50-CN-18	2
-19	FTSH-50-CN-19	2
-20	FTSH-50-CN-20	2
-21	FTSH-50-CN-21	2
-22	FTSH-50-CN-22	2
-23	FTSH-50-CN-23	2
-24	FTSH-50-CN-24	2
-25	FTSH-50-CN-25	2

FIG 4

SCALE 2 : 1

-EJ OPTION

(DIFFERENT AS SHOWN, OTHERWISE SAME AS FIG 1)

(-01 LEAD STYLE ONLY)

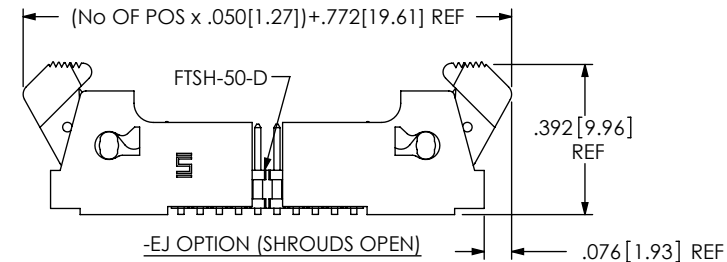
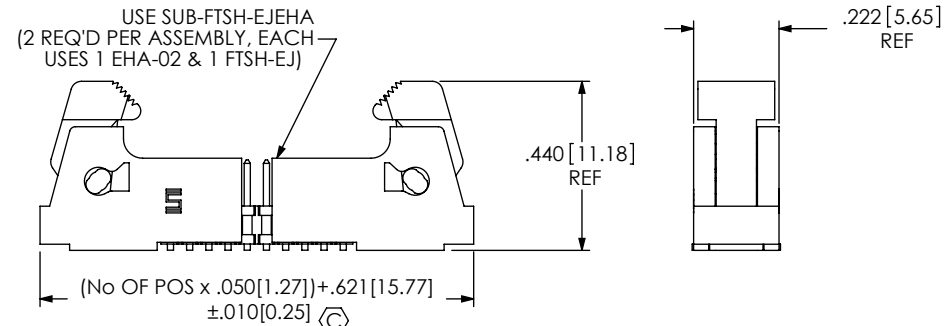

FIG 3

-A OPTION

(DIFFERENT AS SHOWN, OTHERWISE SAME AS FIG 1)

(6 POSITION MINIMUM FOR STAKED ALIGNMENT PINS)

(3 POSITION MINIMUM FOR MOLDED ALIGNMENT PINS)

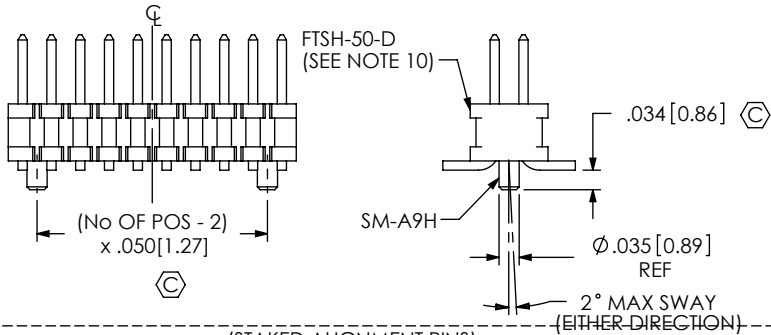

(STAKED ALIGNMENT PINS)

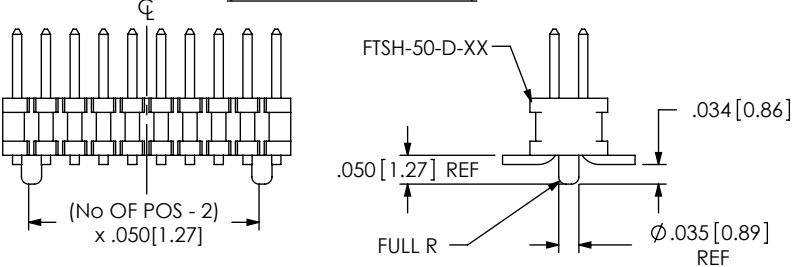

(MOLDED ALIGNMENT PINS)

F:\DWG\MISC\MKTG\FTSH-1XX-XX-XXX-DV-XXX-MKT.SLDDRW

FIG 5

SCALE 2 : 1

-EJC & -EJM OPTIONS

(DIFFERENT AS SHOWN, OTHERWISE SAME AS FIG 4)

(-01 LEAD STYLE ONLY)

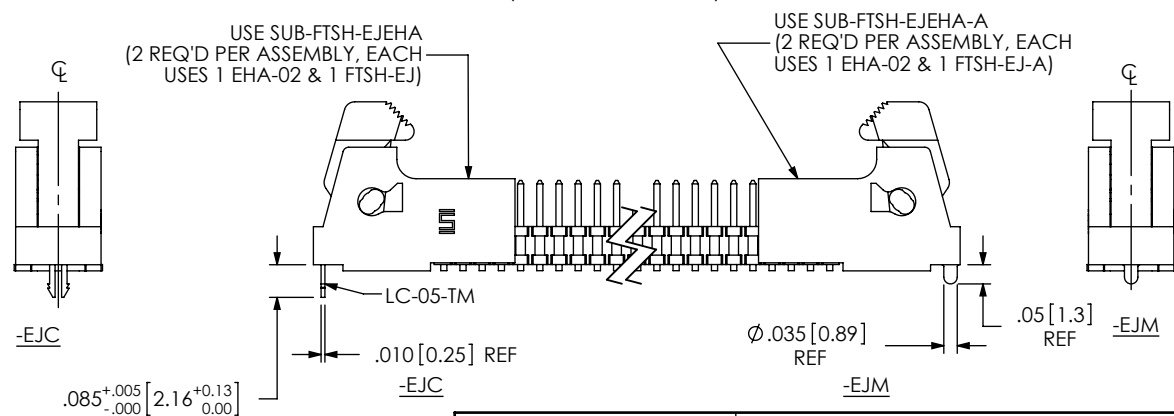

PROPRIETARY NOTE

THIS DOCUMENT CONTAINS INFORMATION CONFIDENTIAL AND PROPRIETARY TO SAMTEC, INC. AND SHALL NOT BE REPRODUCED OR TRANSFERRED TO OTHER DOCUMENTS OR DISCLOSED TO OTHERS OR USED FOR ANY PURPOSE OTHER THAN THAT WHICH IT WAS OBTAINED WITHOUT THE EXPRESSED WRITTEN CONSENT OF SAMTEC, INC.

DO NOT SCALE DRAWING

SHEET SCALE: 3:1

**samtec**

520 PARK EAST BLVD, NEW ALBANY, IN 47150  
PHONE: 812-944-6733 FAX: 812-948-5047  
e-Mail: info@SAMTEC.com code 53322

DESCRIPTION:  
.050 x .050 CL DOUBLE VERTICAL SMT TERMINAL STRIP

DWG. NO.  
**FTSH-1XX-XX-XXX-DV-XXX**

BY: PURVIS 10/12/1995 SHEET 2 OF 5

**FIG 6**  
-ES OPTION  
(DIFFERENT AS SHOWN, OTHERWISE SAME AS FIG 1)  
(USE -02 OR -03 LEAD STYLE ONLY)  
(9 POS MIN FOR SNAP SHROUDS)  
(5 POS MIN FOR MOLDED SHROUDS)

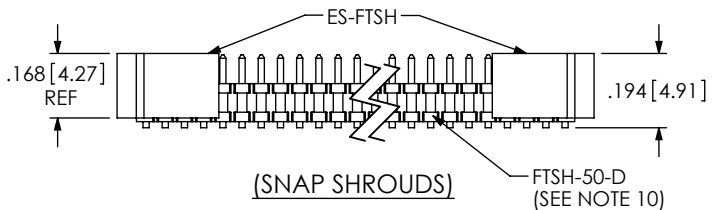
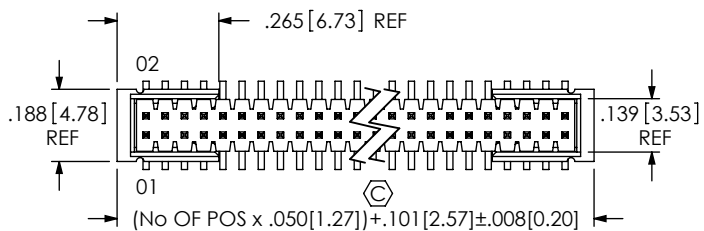

(SNAP SHROUDS)

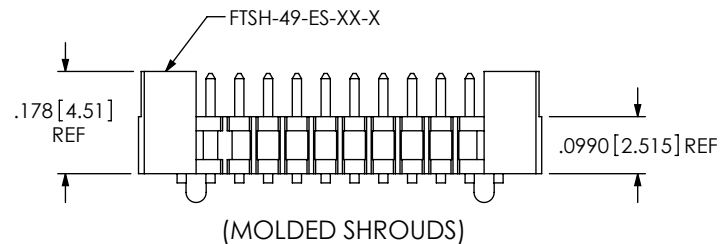
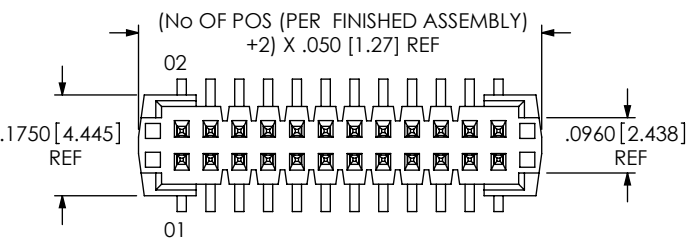

(MOLDED SHROUDS)

**FIG 7**  
-EC OPTION  
(DIFFERENT AS SHOWN, OTHERWISE SAME AS FIG 6)

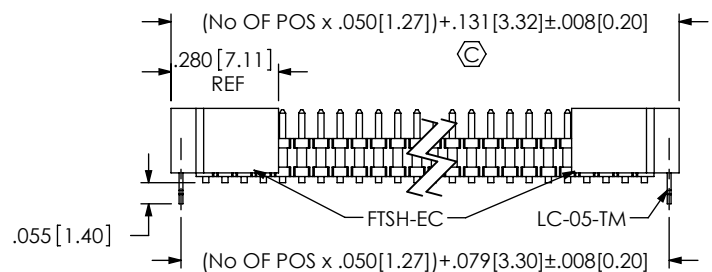

F:\DWG\MISC\MKTG\FTSH-1XX-XX-XXX-DV-XXX-MKT.SLDDRW

**FIG 8**  
-EP OPTION  
(DIFFERENT AS SHOWN, OTHERWISE SAME AS FIG 6)  
(USE ONLY WHEN MATING WITH CLP)

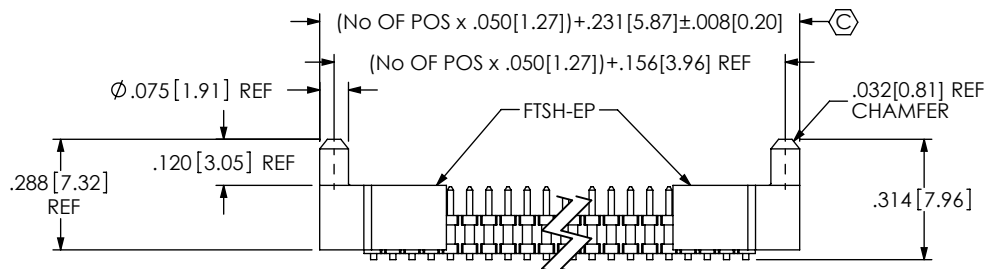

**FIG 9**  
-EL OPTION  
(DIFFERENT AS SHOWN, OTHERWISE SAME AS FIG 6)  
(USE ONLY WHEN MATING WITH CLP)

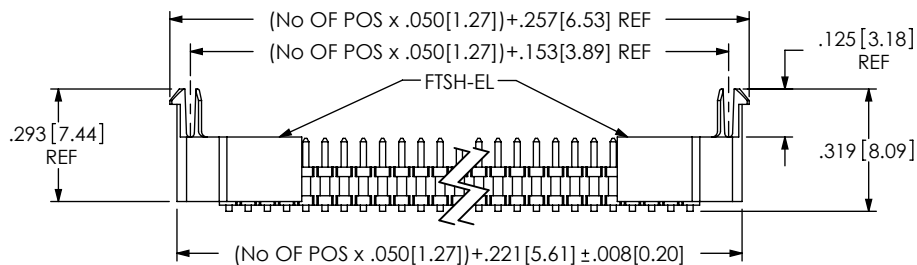

**FIG 10**  
-EPC OPTION  
(DIFFERENT AS SHOWN, OTHERWISE SAME AS FIG 6)  
(USE ONLY WHEN MATING WITH CLP)

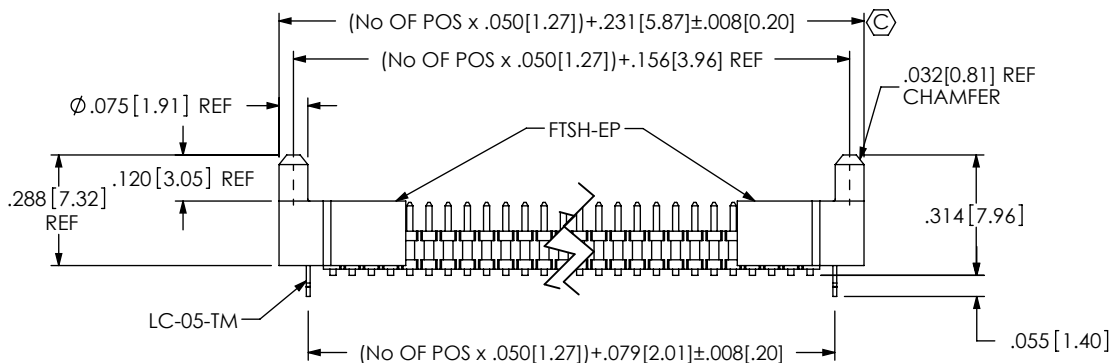

**PROPRIETARY NOTE**

THIS DOCUMENT CONTAINS INFORMATION CONFIDENTIAL AND PROPRIETARY TO SAMTEC, INC. AND SHALL NOT BE REPRODUCED OR TRANSFERRED TO OTHER DOCUMENTS OR DISCLOSED TO OTHERS OR USED FOR ANY PURPOSE OTHER THAN THAT WHICH IT WAS OBTAINED WITHOUT THE EXPRESSED WRITTEN CONSENT OF SAMTEC, INC.

DO NOT SCALE DRAWING

SHEET SCALE: 2:1

**samtec**

520 PARK EAST BLVD, NEW ALBANY, IN 47150  
PHONE: 812-944-6733 FAX: 812-948-5047  
e-Mail info@SAMTEC.com code 53322

DESCRIPTION:  
.050 x .050 CL DOUBLE VERTICAL SMT TERMINAL STRIP

DWG. NO.  
**FTSH-1XX-XX-XXX-DV-XXX**

BY: PURVIS 10/12/1995 SHEET 3 OF 5

REVISION ET

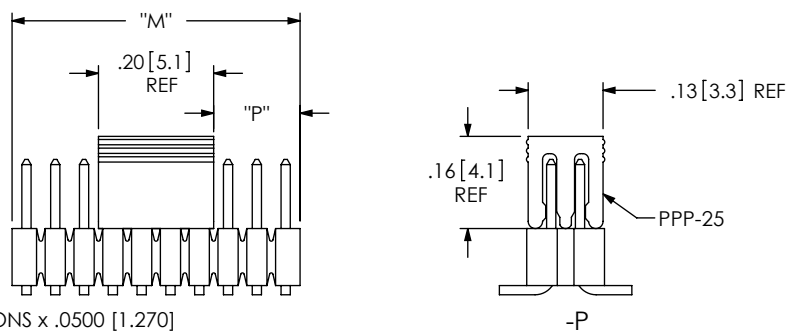

"M" = No OF POSITIONS x .0500 [1.270]  
 "P" = {("M" -.200 [508]) / 2} ±.020 [.51]

FIG 11  
 -P OPTION  
 (DIFFERENT AS SHOWN,  
 OTHERWISE SAME AS FIG 1)

TABLE 5		
OPTION(S)	PAD	MIN. POS
NONE, -A	PPP-25**	4
-EJ, -EJC, -EJM	PPP-41	10
-ES, -EC, -EP, -EL	PPP-25**	9
-EPC	PPP-25**	5*
-K	PPP-25-KT	5
-K-EJ	PPP-25-KT	10

\*MOLDED SHROUD ONLY  
 \*\* USE PPP-25-NT WITH -TR  
 PACKAGING ONLY

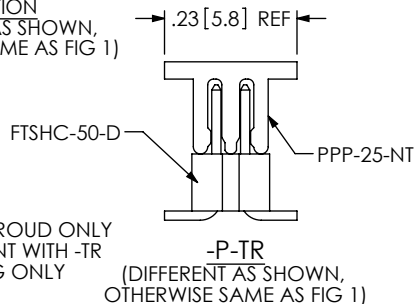

-K-P-TR  
 (DIFFERENT AS SHOWN,  
 OTHERWISE SAME AS FIG 2)

NOTE: TAPE & REEL ORIENTATION:  
 POLARIZATION NOTCH TO THE RIGHT

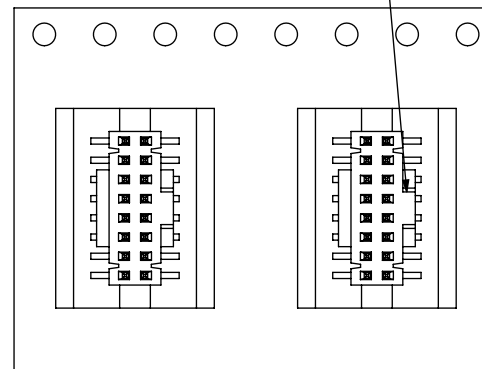

TAPE & REEL VIEW  
 USER DIRECTION OF UN-REELING →  
 POCKET NOT DETAILED

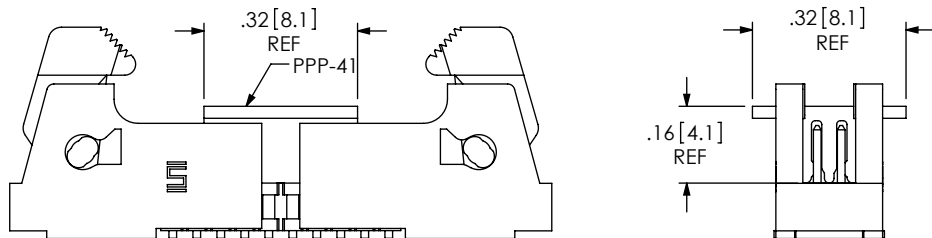

-EJ-P & -EJX -P  
 (DIFFERENT AS SHOWN,  
 OTHERWISE SAME AS FIGS 4 & 5)

FIG 12  
 \*-M: METAL PICK & PLACE PAD  
 (DIFFERENT AS SHOWN, OTHERWISE SAME AS FIG 1)  
 (NOT AVAILABLE WITH -K OPTION)(5 POS MIN)  
 \* = NOT ENGINEERING APPROVED

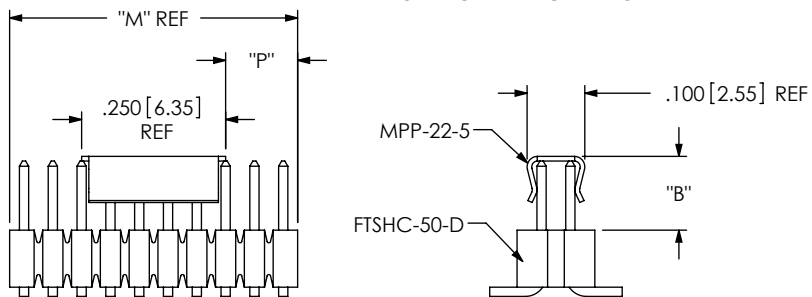

"M" = No OF POSITIONS x .0500[1.270]  
 "P" = {("M" -.250[6.35]) / 2} ± .020[0.51]

TABLE 4	
LEAD STYLE	"B" REF
-01	.125 [3.18]
-02	.080 [2.03]
-03	.070 [1.78]
-04	.155 [3.94]
-14	.155 [3.94]

PROPRIETARY NOTE  
 THIS DOCUMENT CONTAINS INFORMATION  
 CONFIDENTIAL AND PROPRIETARY TO  
 SAMTEC, INC. AND SHALL NOT BE REPRODUCED  
 OR TRANSFERRED TO OTHER DOCUMENTS OR  
 DISCLOSED TO OTHERS OR USED FOR ANY  
 PURPOSE OTHER THAN THAT WHICH IT WAS  
 OBTAINED WITHOUT THE EXPRESSED WRITTEN  
 CONSENT OF SAMTEC, INC.

DO NOT SCALE DRAWING  
 SHEET SCALE: 3:1



520 PARK EAST BLVD, NEW ALBANY, IN 47150  
 PHONE: 812-944-6733 FAX: 812-948-5047  
 e-Mail info@SAMTEC.com code 53322

DESCRIPTION:  
 .050 x .050 CL DOUBLE VERTICAL SMT TERMINAL STRIP

DWG. NO.  
**FTSH-1XX-XX-XXX-DV-XXX**

BY: PURVIS 10/12/1995 SHEET 4 OF 5

FIG 13  
TUBE VIEWS

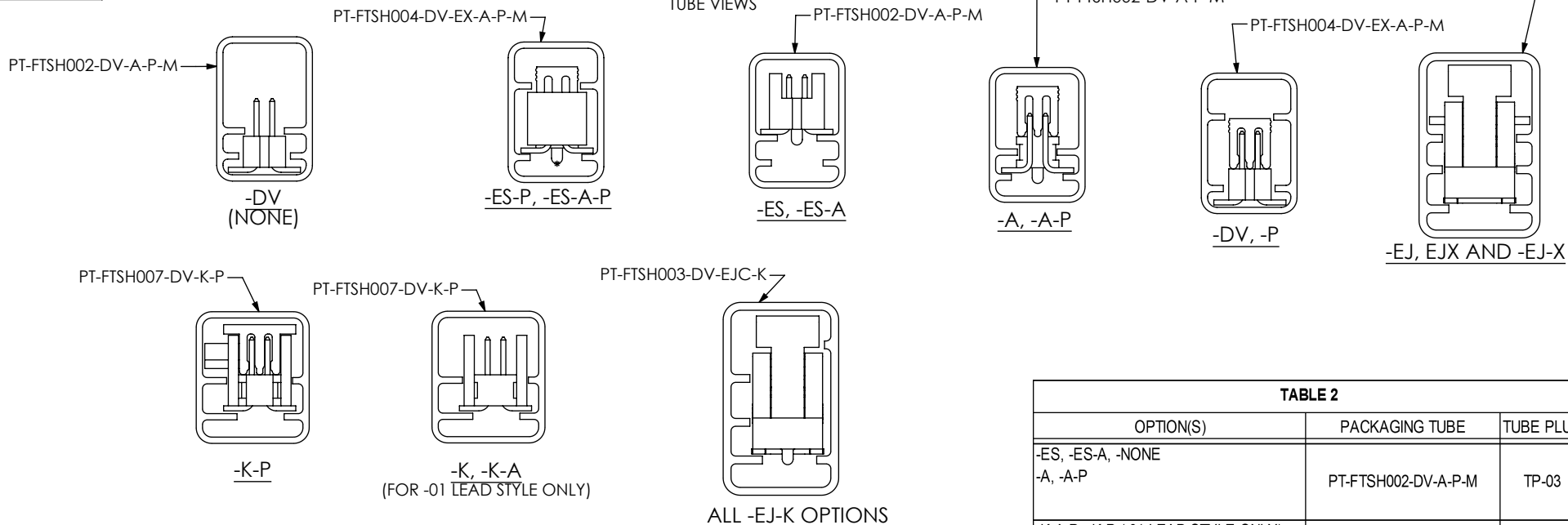
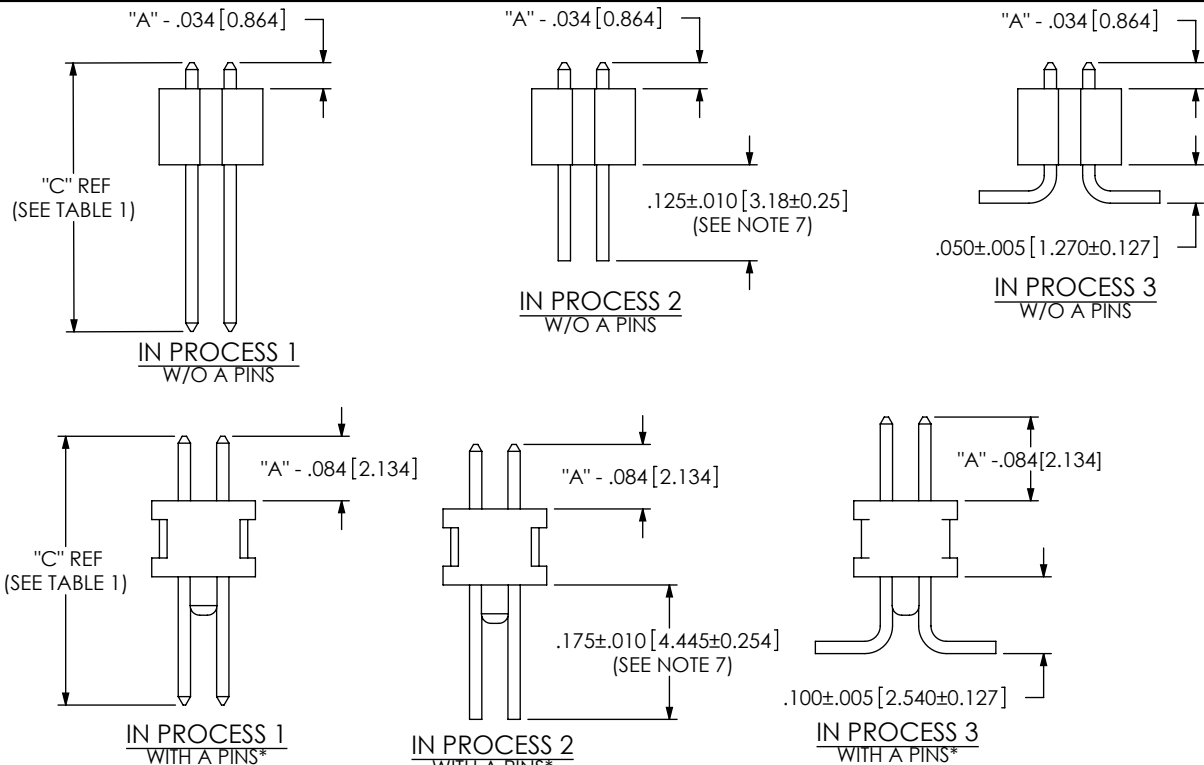

TABLE 2		
OPTION(S)	PACKAGING TUBE	TUBE PLUG
-ES, -ES-A, -NONE -A, -A-P	PT-FTSH002-DV-A-P-M	TP-03
-K-A-P, -K-P (-01 LEAD STYLE ONLY) -K-P (-04 LEAD STYLE ONLY) -K, -K-A (FOR -01 LEAD STYLE ONLY)	PT-FTSH007-DV-K-P	TP-09
-ES-P, -ES-A-P -EC, -EC-P, -EL-P -EP, -EP-A, EP-P, -EP-A-P -EPC, -EPC-D, -EPC-P -EL, -EL-A, -EL-A-P -P (ALL LEAD STYLES)	PT-FTSH004-DV-EX-A-P-M	TP-03
-EJ-K, -EJ-K-P -EJ-K-A, -EJ-K-A-P	PT-FTSH003-DV-EJC-K	TP-03
-EJ, -EJ-P, -EJ-A-P, -EJ-A, -EJM, -EJC	PT-FTSH006-DV-EJC-K-P	TP-03



\* = FOR -01, -04, -05 AND -14 LEAD STYLES ONLY

IN-PROCESS VIEWS ARE FOR HANDFILL ONLY

PROPRIETARY NOTE  
THIS DOCUMENT CONTAINS INFORMATION  
CONFIDENTIAL AND PROPRIETARY TO  
SAMTEC, INC. AND SHALL NOT BE REPRODUCED  
OR TRANSFERRED TO OTHER DOCUMENTS OR  
DISCLOSED TO OTHERS OR USED FOR ANY  
PURPOSE OTHER THAN THAT WHICH IT WAS  
OBTAINED WITHOUT THE EXPRESSED WRITTEN  
CONSENT OF SAMTEC, INC.

DO NOT SCALE DRAWING

SHEET SCALE: 2:1



520 PARK EAST BLVD, NEW ALBANY, IN 47150  
PHONE: 812-944-6733 FAX: 812-948-5047  
e-Mail info@SAMTEC.com code 53322

DESCRIPTION:  
.050 x .050 CL DOUBLE VERTICAL SMT TERMINAL STRIP

DWG. NO.  
**FTSH-1XX-XX-XXX-DV-XXX**

BY: PURVIS 10/12/1995 SHEET 5 OF 5

## X-ON Electronics

Largest Supplier of Electrical and Electronic Components

*Click to view similar products for [Headers & Wire Housings](#) category:*

*Click to view products by [Samtec](#) manufacturer:*

Other Similar products are found below :

[95000-104TRLF](#) [10135584-644402LF](#) [DF62W-EP2022PCA](#) [95000-106TRLF](#) [DF62W-2022SCA](#) [DF62W-EP2022PC](#) [2203348](#) [DF62W-2022SC](#) [1084018](#) [1029039](#) [1084017](#) [802-10-012-10-002000](#) [1112640](#) [1112639](#) [000-34000](#) [0009482033](#) [0009507031](#) [57102-S06-03LF](#) [57202-S52-04LF](#) [PCN6-15S-2.5E](#) [0039019024](#) [58102-G61-06LF](#) [582553-1](#) [0009485154](#) [0009508121](#) [0022285053](#) [0050291907](#) [018731A](#) [LY20-4P-DT1-P1E-BR](#) [02.125.8002.8](#) [60101931](#) [60598-1 \(Cut Strip\)](#) [M1625-3R/100](#) [61062-3](#) [61082-181009](#) [636-1427](#) [638009-1](#) [641938-9](#) [641991-4](#) [644168-1](#) [647662-1](#) [65039-019ELF](#) [65817-002LF](#) [65817-015LF](#) [65863-015LF](#) [66207-023LF](#) [67016-026LF](#) [67046-001LF](#) [67095-007LF](#) [67230-005LF](#)