

NOTES:

1. MINIMUM PUSHOUT FORCE TO BE 12 OZ RETENTION FOR CONTACTS AND WELD TABS.
2. COPLANARITY: .004[.10] = POS 02 THRU 26
.006[.15] = POS 27 THRU 50
3. NOTE DELETED.
4. Ⓞ REPRESENTS A CRITICAL DIMENSION.
5. [] DIMENSIONS ARE IN MILLIMETERS.
6. MEASURED FROM BEND.
7. DIMENSION CHANGED PER REVISION AD.
CONTACT ENGINEERING FOR INFORMATION.
8. SIDES OF PLASTIC BODIES ON ALL LEAD STYLES EXCEPT THE -01 & -02 WILL BE SOLID, NOT RIBBED.
9. MEASURE FROM TIPS OF PIN.
10. NOTE DELETED.
11. .003[.08] MAXIMUM TERMINAL BURR.
12. .005 MAXIMUM HEIGHT VARIATION BETWEEN ANY TWO PINS.
13. MINIMUM LOCKING CLIP RETENTION TO BE 8 OZS.
14. THIS FEATURE ONLY PRESENT ON -01 & -02 LEAD STYLES.
15. AVAILABLE IN -05, -07, -10, -15, -20, -25 & -30 POS. ONLY.
16. DUE TO THE HIGH AMOUNT OF INSERTION FORCE NEEDED, THE -LC OPTION IS NOT COMPATIBLE WITH AUTO PLACEMENT. SAMTEC RECOMMENDS MANUAL PLACEMENT FOR ALL ASSEMBLIES WITH THE -LC OPTION.

DO NOT SCALE FROM THIS PRINT

TFM-1XX-XX-XXX-X-XXX

EC

- LEAD STYLE -01: (-02 THRU -50 ALL POSITIONS AVAILABLE)
LEAD STYLE -02: (-02 THRU -50 ALL POSITIONS AVAILABLE)
ALL OTHER LEAD STYLES: (-5 THRU -50 MULTIPLES OF 5)
LEAD STYLES -11, -12 POS 12, 16, 17 ALSO AVAILABLE
LEAD STYLES -21, -22, -31, -32 POS 12 AND 13 ALSO AVAILABLE

No OF POSITIONS

LEAD STYLE

- | THROUGH HOLE | SURFACE MOUNT |
|-----------------------|------------------|
| -01, -03 (SEE FIG. 1) | -02 (SEE FIG. 2) |
| -11, -13 (SEE FIG. 1) | -12 (SEE FIG. 2) |
| -21, -23 (SEE FIG. 1) | -22 (SEE FIG. 2) |
| -31 (SEE FIG. 1) | -32 (SEE FIG. 2) |

PLATING SPECIFICATION

- S: SELECTIVE, 30 Au / 50 Ni MIN ON CONTACT, MATTE TIN TAIL
- L: LIGHT SELECTIVE, 15 Au / 50 Ni MIN ON CONTACT, MATTE TIN TAIL
- F: FLASH GOLD, 3 Au / 50 Ni MIN ON CONTACT, MATTE TIN TAIL
- H: HEAVY GOLD, 30 Au / 50 Ni MIN ON CONTACT, 3 Au / 50 Ni MIN ON TAIL
- SM: SELECTIVE, 30 Au / 50 Ni MIN ON CONTACT, MATTE TIN TAIL
- LM: LIGHT SELECTIVE, 15 Au / 50 Ni MIN ON CONTACT, MATTE TIN TAIL
- FM: FLASH GOLD, 3 Au / 50 Ni MIN ON CONTACT, MATTE TIN TAIL
- STL: SELECTIVE, 30 Au / 50 Ni MIN ON CONTACT, TIN/LEAD (90/10+/-5%) TAIL

BODY SPECIFICATION

- D: DOUBLE ROW

OPTION

- A: ALIGNMENT PIN (USE TFM-XX-D-XX-A, SEE TABLE 1) (SEE FIG. 8 SHEET 3) (NOT AVAILABLE FOR -RA OR -REX)
- LC: LOCKING CLIP (USE LC-05-TM) SEE NOTE 16 (NOT AVAILABLE FOR -RA OR -REX) (SEE FIG. 10 SHEET 3) (SEE NOTE 13)
- P: PICK AND PLACE PAD (USE PPP-04) (AVAILABLE IN ALL POSITIONS EXCEPT -05 WITH -WT) (NOT AVAILABLE FOR -RA OR -REX, SEE FIG. 7 SHEET 3)
- RA: RIGHT ANGLE (AVAILABLE ONLY IN LEAD STYLE: -01 SEE FIG. 5, SHEET 2)
- TR: TAPE AND REEL (SEE FIG. 4, SHEET 5)
- SA: STAKED ALIGNMENT PIN (SEE FIG. 9, SHEET 3) (NOT AVAILABLE FOR -RA OR -RE)
- K: POLYIMIDE FILM (SEE FIG. 3) (NOT AVAILABLE FOR -RA OR -REX)
- WT: WELD TABS (USE WT-25-XX-T) (AVAILABLE ON -01 AND -02 LEAD STYLES ONLY) (SEE FIG. 6 SHEET 2) (NOT AVAILABLE WITH -A, -LC, -RA, OR -SA OPTIONS)
- RE1: RIGHT ANGLE ELEVATED .062 PCB (USE TFM-XX-D-01-RE, NOT AVAILABLE WITHOUT -WT, AVAILABLE IN LEAD STYLE -01 ONLY, -05 THRU -50 POS) (SEE FIG. 11, SHEET 4) (SEE NOTE 15)
- RE2: RIGHT ANGLE ELEVATED .093 PCB (USE TFM-XX-D-01-RE, NOT AVAILABLE WITHOUT -WT, AVAILABLE IN LEAD STYLE -01 ONLY, -05 THRU -50 POS) (SEE FIG. 11, SHEET 4) (SEE NOTE 15)
- SN: SOLDER NAIL FOR .062 BOARD (TFM-XX-D-01-SN AND WT-27-01-T) (SEE FIG. 12, SHT 3) (ONLY AVAILABLE WITH -02 LEAD STYLE) (NOT AVAILABLE WITH OPTIONS -A, -LC, -RA, -SA, -WT, -RE1 OR -RE2)
- SN2: SOLDER NAIL FOR .093 BOARD (TFM-XX-D-01-SN AND WT-27-02-T) (SEE FIG. 12, SHT 3) (ONLY AVAILABLE WITH -02 LEAD STYLE) (NOT AVAILABLE WITH OPTIONS -A, -LC, -RA, -SA, -WT, -RE1 OR -RE2)

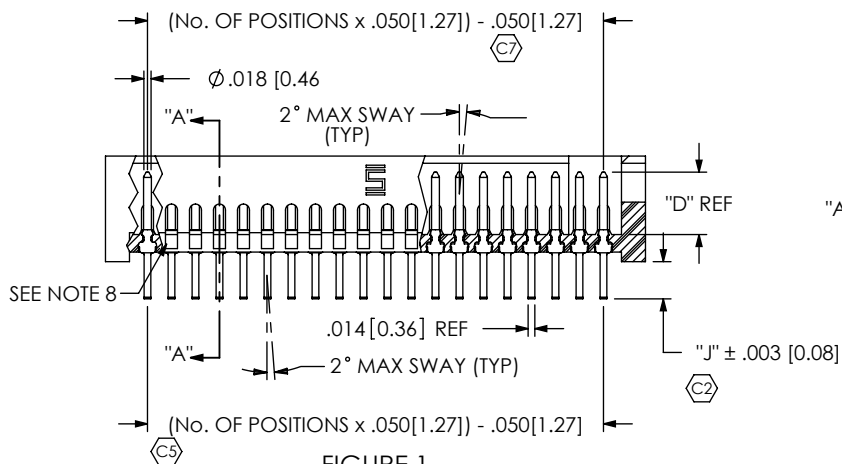
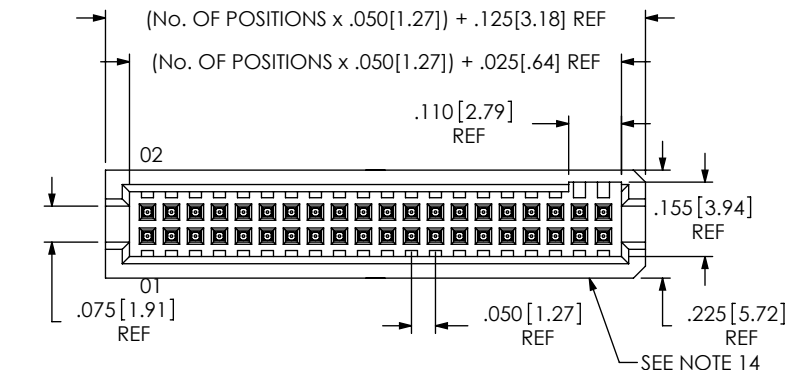
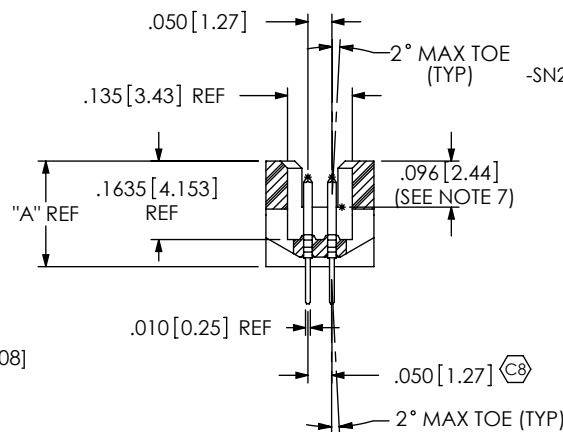
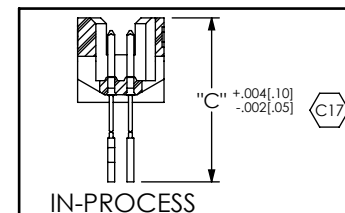

FIGURE 1 THROUGH HOLE -01, -03, -11, -13, -21, -23, -31



SECTION "A"- "A"



IN-PROCESS

LEAD STYLE	BODY	"A"	TERMINAL 1	TERMINAL 2	"C"	"D"	"E"	"J"
-01, -02	TFM-XX-D-01-XX	2200 [5.588]	T-1R16-01-XX-2	N/A	0.427 [10.85]	0.133 [3.38]	0.230 [5.84]	0.078 [1.97]
-11, -12	TFM-XX-D-02-XX	2900 [7.366]	T-1R20-03-XX	N/A	0.644 [16.36]	0.141 [3.58]	0.300 [7.62]	0.078 [1.97]
-21, -22	TFM-XX-D-03-XX	3600 [9.144]	T-1R20-04-XX	N/A	0.644 [16.36]	0.141 [3.58]	0.370 [9.40]	0.078 [1.97]
-31, -32	TFM-XX-D-04-XX	4300 [11.049]	T-1R20-02-XX	N/A	0.644 [16.36]	0.141 [3.58]	0.446 [11.30]	0.078 [1.97]
-01-RA	TFM-XX-D-01-XX	2200 [5.588]	T-1R16-02-XX	T-1R16-03-XX	N/A	0.133 [3.38]	0.230 [5.84]	N/A N/A
-01-RE1	TFM-XX-D-01-RE	2400 [6.096]	T-1R16-06-XX	T-1R16-07-XX	N/A	0.138 [3.51]	N/A	N/A N/A
-01-RE2	TFM-XX-D-01-RE	2400 [6.096]	T-1R16-08-XX	T-1R16-09-XX	N/A	0.138 [3.51]	N/A	N/A N/A
-03	TFM-XX-D-01-XX	2200 [5.588]	T-1R16-10-XX	N/A	0.644 [16.36]	0.141 [3.58]	0.230 [5.84]	0.109 [2.77]
-13	TFM-XX-D-02-XX	2900 [7.366]	T-1R20-05-XX	N/A	0.644 [16.36]	0.141 [3.58]	0.300 [7.62]	0.109 [2.77]
-23	TFM-XX-D-03-XX	3600 [9.144]	T-1R20-06-XX	N/A	0.644 [16.36]	0.141 [3.58]	0.370 [9.40]	0.109 [2.77]

UNLESS OTHERWISE SPECIFIED, DIMENSIONS ARE IN INCHES. TOLERANCES ARE:

DECIMALS ANGLES
.XX: ±.01 [.3] 2°
.XXX: ±.005 [.13]
.XXXX: ±.0020 [.051]

PROPRIETARY NOTE

THIS DOCUMENT CONTAINS INFORMATION CONFIDENTIAL AND PROPRIETARY TO SAMTEC, INC. AND SHALL NOT BE REPRODUCED OR TRANSFERRED TO OTHER DOCUMENTS OR DISCLOSED TO OTHERS OR USED FOR ANY PURPOSE OTHER THAN THAT WHICH IT WAS OBTAINED WITHOUT THE EXPRESSED WRITTEN CONSENT OF SAMTEC, INC.

MATERIAL: DO NOT SCALE DRAWING SHEET SCALE: 2.5:1

INSULATOR: LCP, UL 94-VO
COLOR: BLACK

TERMINAL: PHOSPHOR BRONZE

F:\DWG\MISC\MKTG\TFM-1XX-XX-XXX-X-XXX-MKT.SLDDRW

samtec
520 PARK EAST BLVD, NEW ALBANY, IN 47150
PHONE: 812-944-6733 FAX: 812-948-5047
e-Mail: info@SAMTEC.com code 55322

DESCRIPTION: .050 X .050 TERMINAL STRIP

DWG. NO. TFM-1XX-XX-XXX-X-XXX

BY: B RAY 7-10-2007 SHEET 1 OF 5

FIGURE 2
SURFACE MOUNT
-02, -12, -22, -32
(DIFFERENT AS SHOWN, OTHERWISE SAME AS FIG. 1)

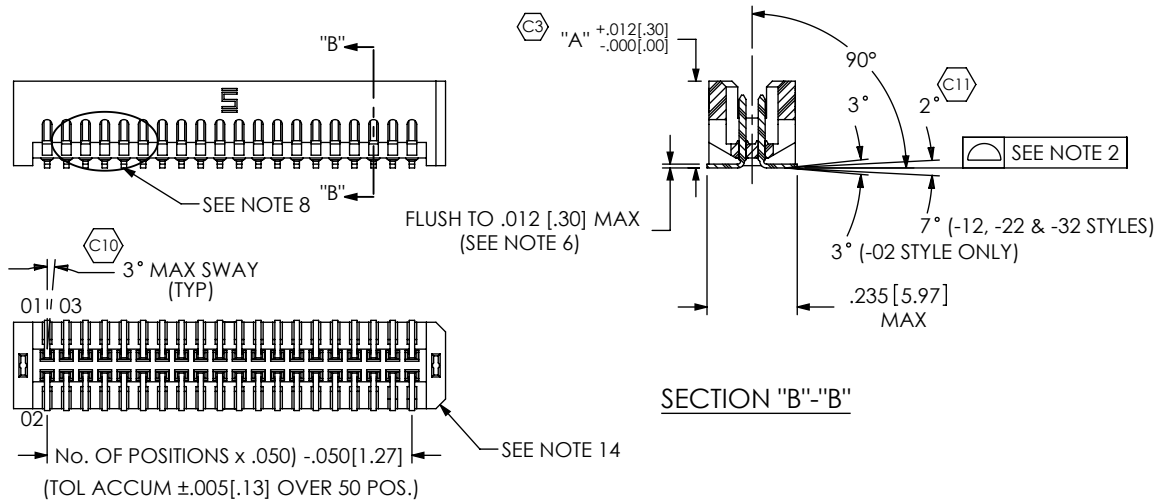

FIGURE 3
-K: POLYIMIDE FILM PAD

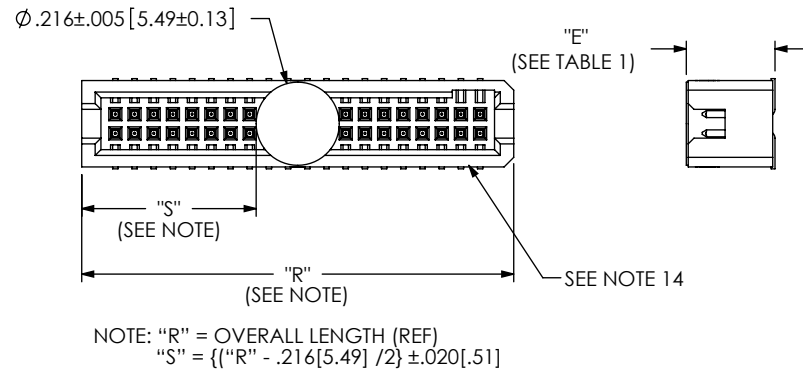

FIGURE 5
-RA OPTION
DIFFERENT AS SHOWN, OTHERWISE SAME AS FIG. 1

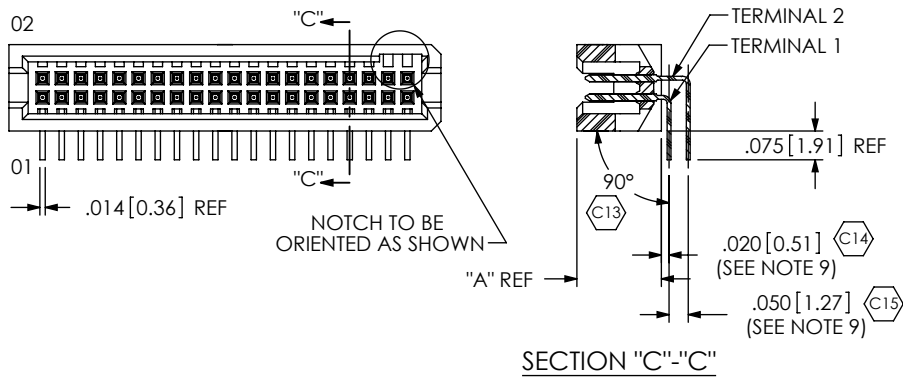
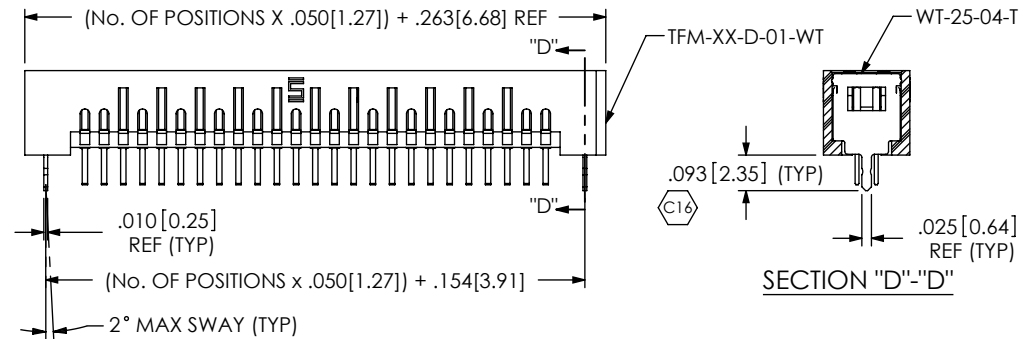
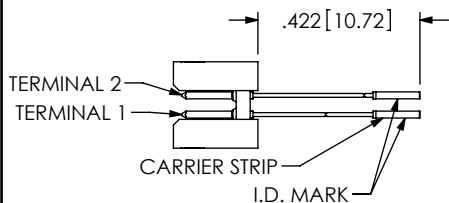

FIGURE 6
-WT OPTION
DIFFERENT AS SHOWN, OTHERWISE SAME AS FIG. 1



IN-PROCESS 1
(ORIENT I.D. MARK AS SHOWN)
(FOR -RA OPTION ONLY)



IN-PROCESS 2

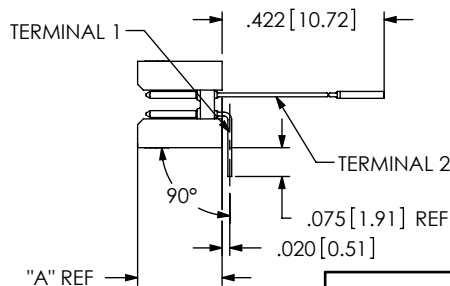

PROPRIETARY NOTE

THIS DOCUMENT CONTAINS INFORMATION CONFIDENTIAL AND PROPRIETARY TO SAMTEC, INC. AND SHALL NOT BE REPRODUCED OR TRANSFERRED TO OTHER DOCUMENTS OR DISCLOSED TO OTHERS OR USED FOR ANY PURPOSE OTHER THAN THAT WHICH IT WAS OBTAINED WITHOUT THE EXPRESSED WRITTEN CONSENT OF SAMTEC, INC.

DO NOT SCALE DRAWING

SHEET SCALE: 2:1



520 PARK EAST BLVD, NEW ALBANY, IN 47150
PHONE: 812-944-6733 FAX: 812-948-5047
e-Mail: info@SAMTEC.com code 55322

DESCRIPTION: .050 X .050 TERMINAL STRIP

DWG. NO. TFM-1XX-XX-XXX-X-XXX

BY: B RAY 7-10-2007 SHEET 2 OF 5

FIGURE 7
-P OPTION

DIFFERENT AS SHOWN, OTHERWISE SAME AS FIG. 1
(PAD TO BE POSITIONED ON C.L. AS SHOWN)

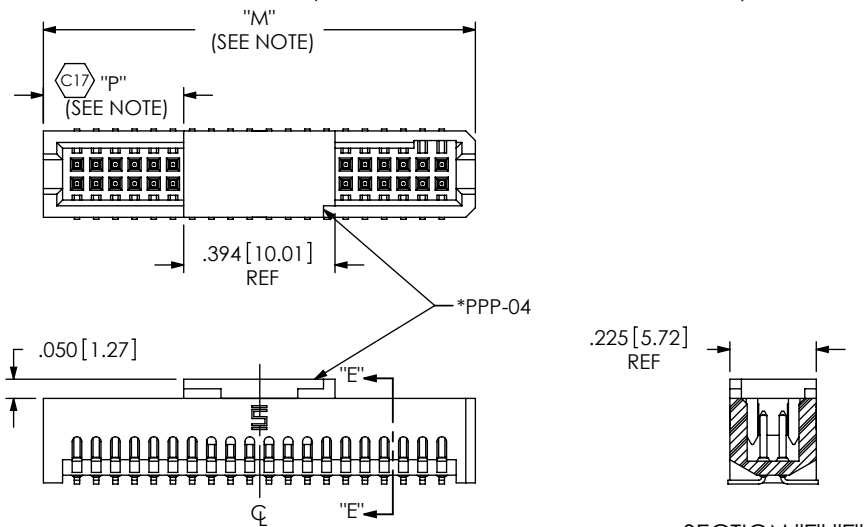

NOTE: "M" = (No. OF POSITIONS X .050[1.27]) + .125[3.18] (REF)
 WITH -WT "M" = (No. OF POSITIONS X .050[1.27]) + .263[6.68] (REF)
 "P" = {("M" - .394[10.01]) / 2} ±.020[.51]

* NOTCH ON PAD TO BE ON SAME END AS THE NOTCH IN THE TFM BODY

SECTION "E"-E

FIGURE 8
-A OPTION

DIFFERENT AS SHOWN, OTHERWISE SAME AS FIG. 1

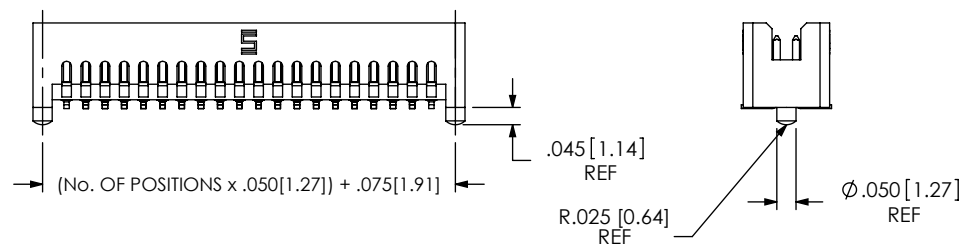

FIGURE 9

-SA OPTION: STAKED ALIGNMENT PIN
 DIFFERENT AS SHOWN, OTHERWISE SAME AS FIG. 1

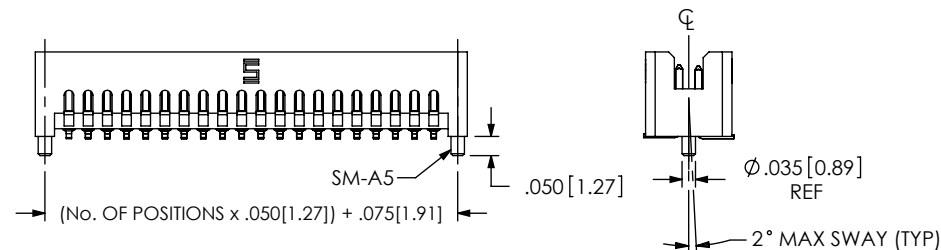

FIGURE 10
-LC OPTION

DIFFERENT AS SHOWN, OTHERWISE SAME AS FIG. 1
(NOT AVAILABLE ON -RA)

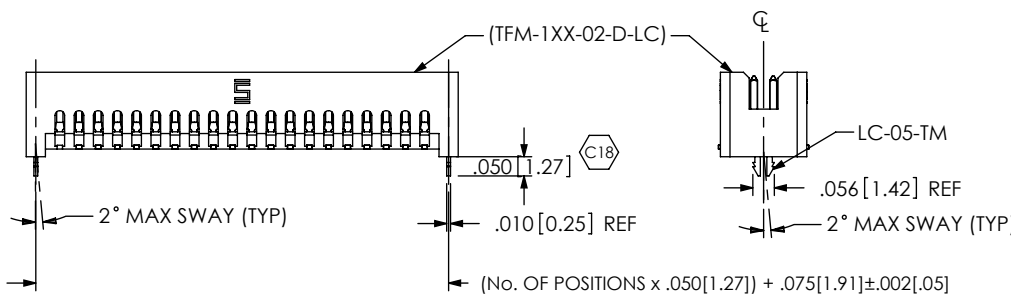

FIGURE 12

-SNX: SOLDER NAIL
 DIFFERENT AS SHOWN, OTHERWISE SAME AS FIG. 1

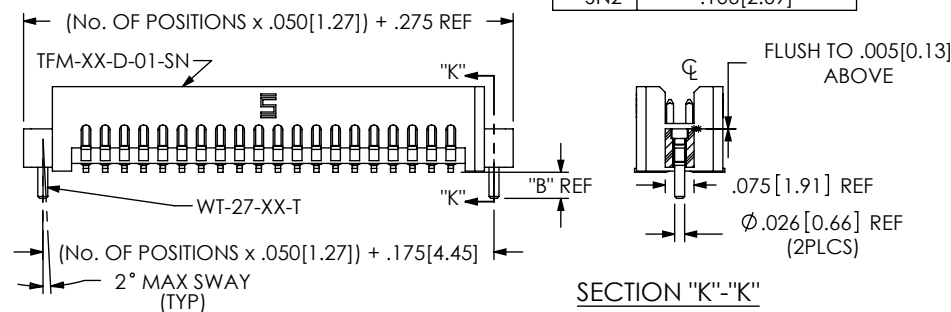

TABLE 4	
OPTION	"B"
-SN	.071[1.80]
-SN2	.106[2.69]

SECTION "K"-K

PROPRIETARY NOTE

THIS DOCUMENT CONTAINS INFORMATION CONFIDENTIAL AND PROPRIETARY TO SAMTEC, INC. AND SHALL NOT BE REPRODUCED OR TRANSFERRED TO OTHER DOCUMENTS OR DISCLOSED TO OTHERS OR USED FOR ANY PURPOSE OTHER THAN THAT WHICH IT WAS OBTAINED WITHOUT THE EXPRESSED WRITTEN CONSENT OF SAMTEC, INC.

DO NOT SCALE DRAWING

SHEET SCALE: 2:1



520 PARK EAST BLVD. NEW ALBANY, IN 47150
 PHONE: 812-944-6733 FAX: 812-948-5047
 e-Mail: info@SAMTEC.com code 55322

DESCRIPTION:	.050 X .050 TERMINAL STRIP
DWG. NO.	TFM-1XX-XX-XXX-X-XXX
BY: B RAY	7-10-2007
	SHEET 3 OF 5

FIGURE 11
 -REX: RIGHT ANGLE ELEVATED
 TFM-120-XX-XXX-D-RE2 SHOWN
 DIFFERENT AS SHOWN, OTHERWISE SAME AS FIG. 1

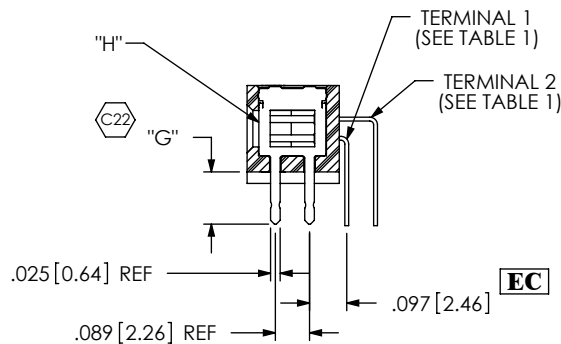
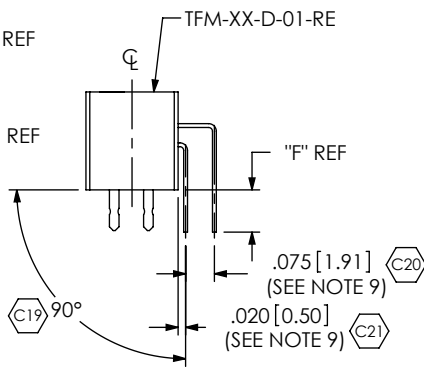
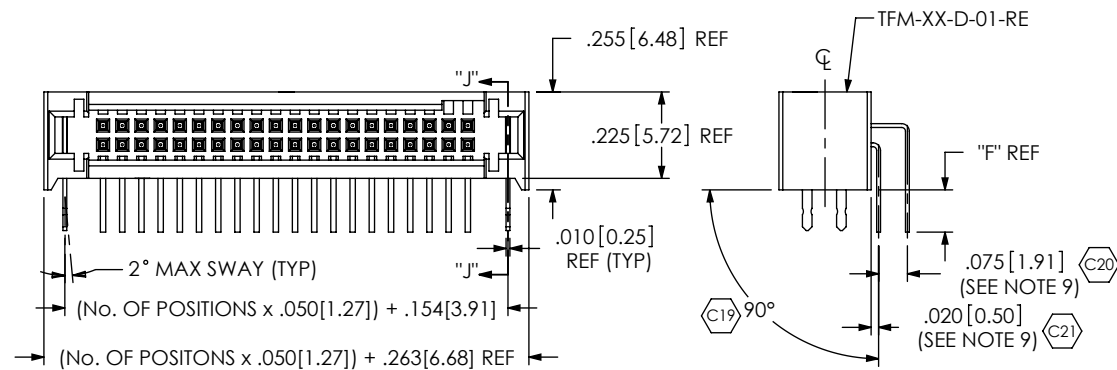
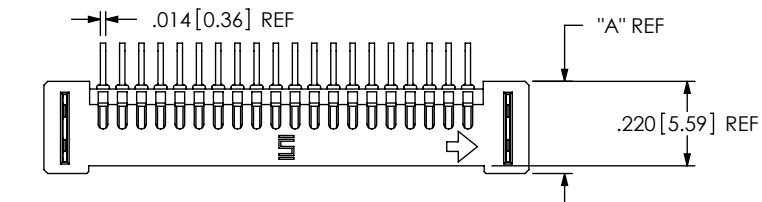

SECTION "J"-"J"

LEAD STYLE	"F"	"G"	"H"
-01-RE1	.078 [1.98]	.074 [1.88]	WT-25-05-T
-01-RE2	.110 [2.79]	.106 [2.69]	WT-25-06-T

IN-PROCESS 1
 (ORIENT I.D. MARK AS SHOWN)
 (FOR -RA OPTION ONLY)

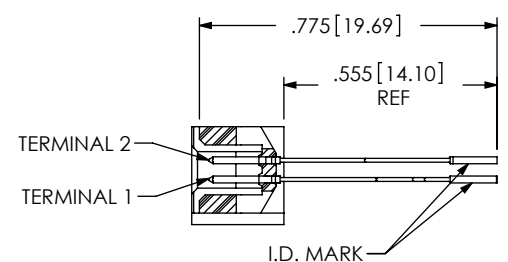

IN-PROCESS 2

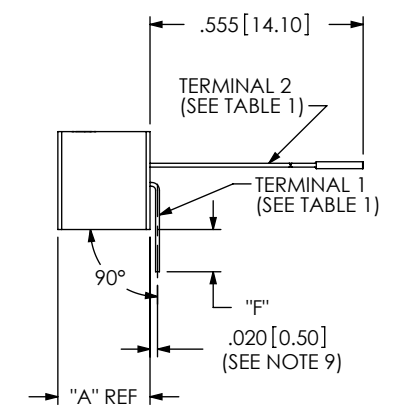

IN-PROCESS 3

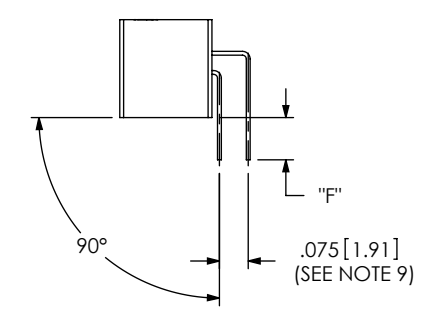

PROPRIETARY NOTE
 THIS DOCUMENT CONTAINS INFORMATION
 CONFIDENTIAL AND PROPRIETARY TO
 SAMTEC, INC. AND SHALL NOT BE REPRODUCED
 OR TRANSFERRED TO OTHER DOCUMENTS OR
 DISCLOSED TO OTHERS OR USED FOR ANY
 PURPOSE OTHER THAN THAT WHICH IT WAS
 OBTAINED WITHOUT THE EXPRESSED WRITTEN
 CONSENT OF SAMTEC, INC.

DO NOT SCALE DRAWING
 SHEET SCALE: 2:1



520 PARK EAST BLVD., NEW ALBANY, IN 47150
 PHONE: 812-944-6733 FAX: 812-948-5047
 e-Mail: info@SAMTEC.com code 55322

DESCRIPTION:
 .050 X .050 TERMINAL STRIP
 DWG. NO.
TFM-1XX-XX-XXX-X-XXX
 BY: B RAY 7-10-2007 SHEET 4 OF 5

PARTS TO BE PACKAGED IN TUBES AS SHOWN

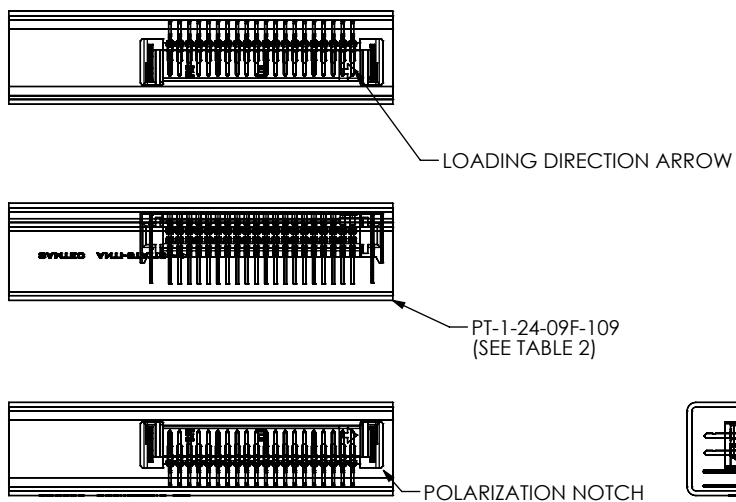
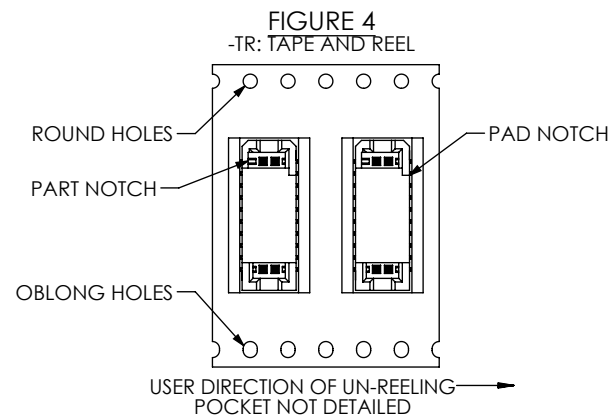
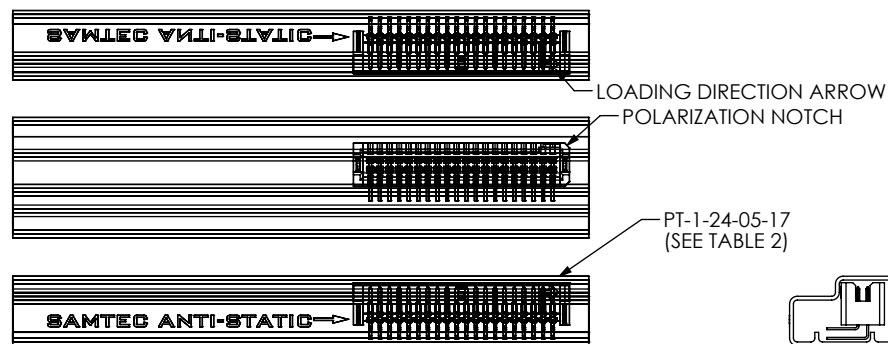
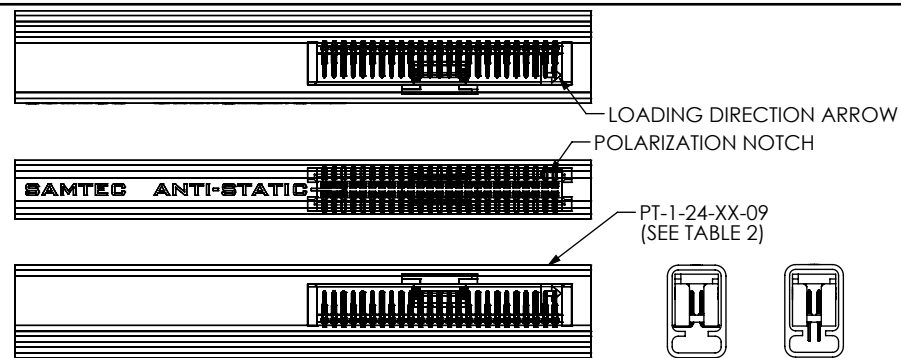
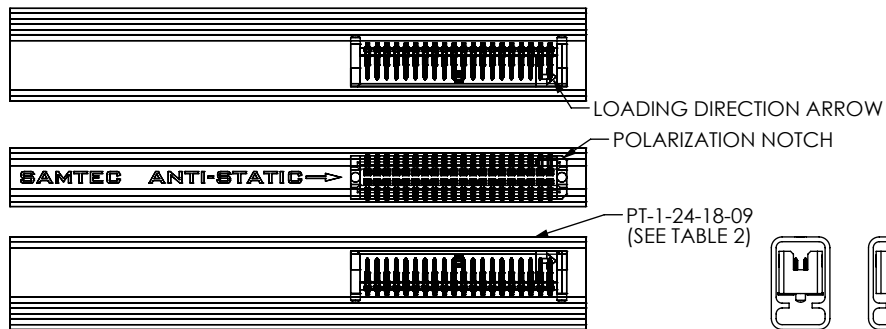

TABLE 2		
LEAD STYLE	PACKAGING TUBE	PLUG
-RA (ALL LEAD STYLES)	PT-1-24-5-17	TP-07
-REX	PT-1-24-09F-109	TP-29
-02, -02-A, -02-A-K, -02-LC	PT-1-24-01-09	TP-24
-12 (ALL OPTIONS), -22-K, -22, -22-A, -22-A-K, -22-LC, -22-LC-K	PT-1-24-04-09	TP-07
-02-A-P, -02-K, -02-LC-K, -02-LC-P, -02-P, -02-WT,A8	PT-1-24-18-09	TP-09
-01 (ALL OPTIONS), -11, -11-A, -11-LC, -11-K, -11-LC-K, -11-A-K		
-03 (ALL OPTIONS)		
-13, -13-A, -13-LC, -13-K, -13-LC-K, -13-A-K	PT-1-24-02-09	TP-07
-31-A-K, -31-A-P, -31-LC-P, -31-P, -32, -32-K, -32-A, -32-A-K, -32-A-P, -32-LC-K, -32-LC-P, -32-P, -32-LC		
-31, -21-P, -22-P, -31-LC, -21-A-P, -21-LC-P, -22-LC-P, -22-A-P, -31-A, -13-P, -13-LC-P, -13-A-P, -21, -23, -23-P, -23-A-P, -11-P, -11-LC-P, -11-A-P, -21-K, -21-A, -21-LC, -21-A-K, -21-LC-K, -23-K, -23-A, -23-A-K, -23-LC, -23-LC-K	PT-1-24-05-09	TP-07
	PT-1-24-20-09	TP-07

NOTE:
PARTS TO BE PACKAGED WITH THE LOADING DIRECTION ARROW POINTED IN SAME DIRECTION AS THE ARROW ON TUBE.

PROPRIETARY NOTE

THIS DOCUMENT CONTAINS INFORMATION CONFIDENTIAL AND PROPRIETARY TO SAMTEC, INC. AND SHALL NOT BE REPRODUCED OR TRANSFERRED TO OTHER DOCUMENTS OR DISCLOSED TO OTHERS OR USED FOR ANY PURPOSE OTHER THAN THAT WHICH IT WAS OBTAINED WITHOUT THE EXPRESSED WRITTEN CONSENT OF SAMTEC, INC.

DO NOT SCALE DRAWING

SHEET SCALE: 2:1



520 PARK EAST BLVD, NEW ALBANY, IN 47150
PHONE: 812-944-6733 FAX: 812-948-5047
e-Mail: info@SAMTEC.com code 55322

DESCRIPTION:
.050 X .050 TERMINAL STRIP

DWG. NO. TFM-1XX-XX-XXX-X-XXX

BY: B RAY 7-10-2007 SHEET 5 OF 5

X-ON Electronics

Largest Supplier of Electrical and Electronic Components

Click to view similar products for [Headers & Wire Housings](#) category:

Click to view products by [Samtec](#) manufacturer:

Other Similar products are found below :

[95000-104TRLF](#) [10135584-644402LF](#) [DF62W-EP2022PCA](#) [95000-106TRLF](#) [DF62W-2022SCA](#) [DF62W-EP2022PC](#) [2203348](#) [DF62W-2022SC](#) [1084018](#) [1029039](#) [1084017](#) [802-10-012-10-002000](#) [1112640](#) [1112639](#) [000-34000](#) [0009482033](#) [0009507031](#) [57102-S06-03LF](#) [57202-S52-04LF](#) [PCN6-15S-2.5E](#) [0039019024](#) [58102-G61-06LF](#) [582553-1](#) [0009485154](#) [0009508121](#) [0022285053](#) [0050291907](#) [018731A](#) [LY20-4P-DT1-P1E-BR](#) [02.125.8002.8](#) [60101931](#) [60598-1 \(Cut Strip\)](#) [M1625-3R/100](#) [61062-3](#) [61082-181009](#) [636-1427](#) [638009-1](#) [641938-9](#) [641991-4](#) [644168-1](#) [647662-1](#) [65039-019ELF](#) [65817-002LF](#) [65817-015LF](#) [65863-015LF](#) [66207-023LF](#) [67016-026LF](#) [67046-001LF](#) [67095-007LF](#) [67230-005LF](#)