

1. $\text{\textcircled{C}}$ REPRESENTS A CRITICAL DIMENSION.
2. MINIMUM PUSHOUT FORCE FOR CONTACTS, WELD TABS, AND THREADED INSERTS: 12 OZ.
3. MINIMUM LOCKING CLIP RETENTION: 8 OZS.
4. MAXIMUM HEIGHT VARIATION BETWEEN ANY TWO PINS: .005[0.13]
5. MAXIMUM TERMINAL BURR: .003[0.08]
6. COPLANARITY: .004[0.10] = POS 02 THRU 26 $\text{\textcircled{C}}$
.006[0.15] = POS 27 THRU 50
7. MEASURED FROM BEND.
8. DIMENSION CHANGED PER REVISION AD. CONTACT ENGINEERING FOR INFORMATION.
9. MEASURE FROM TIPS OF PIN.
10. THIS FEATURE ONLY PRESENT ON -01 & -02 LEAD STYLES.
11. DUE TO THE HIGH AMOUNT OF INSERTION FORCE NEEDED, THE -LC OPTION IS NOT COMPATIBLE WITH AUTO PLACEMENT. SAMTEC RECOMMENDS MANUAL PLACEMENT FOR ALL ASSEMBLIES WITH THE -LC OPTION.
12. SIDES OF PLASTIC BODIES ON ALL LEAD STYLES EXCEPT THE -01, -02 & -03 WILL BE SOLID AND WITHOUT SIDE SLOTS.
13. NOTE DELETED.

DO NOT SCALE FROM THIS PRINT

No OF POSITIONS
LEAD STYLE -01, -02, -03: -02 THRU -50 (ALL POSITIONS AVAILABLE)
LEAD STYLES -11, -12, -13: (-05 THRU -50 MULTIPLES OF 5) POSITIONS 12, 16, 17 ALSO AVAILABLE
LEAD STYLES -21, 22, 23: (-05 THRU -50 MULTIPLES OF 5) POSITIONS 12 & 13 ALSO AVAILABLE
LEAD STYLES 31, 32: 12 POSITION ALSO AVAILABLE

LEAD STYLE

THROUGH HOLE	SURFACE MOUNT
-01, -03 (SEE FIG 1)	-02 (SEE FIG 2)
-11, -13 (SEE FIG 1)	-12 (SEE FIG 2)
-21, -23 (SEE FIG 1)	-22 (SEE FIG 2)
-31 (SEE FIG 1)	-32 (SEE FIG 2)

PLATING SPECIFICATION

- S: 30 μ " SELECTIVE GOLD ON CONTACT AREA, MATTE TIN TAIL
- L: 15 μ " SELECTIVE GOLD ON CONTACT AREA, MATTE TIN TAIL
- F: 3 μ " FLASH GOLD ON CONTACT AREA, MATTE TIN TAIL
- H: 30 μ " SELECTIVE GOLD ON CONTACT AREA, 3 μ " FLASH GOLD ON TAIL
- SM: 30 μ " SELECTIVE GOLD ON CONTACT AREA, MATTE TIN TAIL
- LM: 15 μ " SELECTIVE GOLD ON CONTACT AREA, MATTE TIN TAIL
- FM: 3 μ " FLASH GOLD ON CONTACT AREA, MATTE TIN TAIL
- STL: 30 μ " SELECTIVE GOLD ON CONTACT AREA, TIN/LEAD (90/10 \pm 5%) TAIL

BODY SPECIFICATION

-D: DOUBLE ROW

OPTION

- A: ALIGNMENT PIN (USE TFM-XX-D-XX-A, SEE TABLE 1) (SEE FIG 8, SHT 3) (NOT AVAILABLE FOR -RA OR -REX)
- LC: LOCKING CLIP (USE LC-05-TM) (NOT AVAILABLE FOR -RA OR -REX) (SEE FIG 10, SHT 3 & NOTES 3 & 11)
- P: PICK AND PLACE PAD (USE PPP-04) (AVAILABLE IN ALL POSITIONS -05 THRU -50 EXCEPT -05 WITH -WT) (NOT AVAILABLE FOR -RA OR -REX, SEE FIG 7, SHT 3)
- RA: RIGHT ANGLE (AVAILABLE ONLY IN LEAD STYLE: -01 SEE FIG 5, SHT 2)
- TR: TAPE AND REEL (SEE FIG 4, SHT 7) (NOT AVAILABLE WITH -DS OPTION OR THROUGH HOLE LEAD STYLE)
- SA: STAKED ALIGNMENT PIN (SEE FIG 9, SHT 3) (ONLY AVAILABLE ON SURFACE MOUNT LEAD STYLE)
- K: POLYIMIDE FILM (SEE FIG 3, SHT 2) (USE K-DOT-.217-.313-.005) (NOT AVAILABLE FOR -RA OR -REX) (ALL LEAD STYLES EXCEPT -21 AVAILABLE)
- WT: WELD TABS (USE WT-25-XX-T) (AVAILABLE ON -01, -02 & -03 LEAD STYLES ONLY) (SEE FIG 6, SHT 2) (MATES WITH SFSS/SFSD -SR & -DR ONLY) (NOT AVAILABLE WITH -A, -LC, -RA, OR -SA OPTIONS)
- RE1: RIGHT ANGLE ELEVATED .062 PCB (USE TFM-XX-D-01-RE, NOT AVAILABLE WITHOUT -WT, AVAILABLE IN LEAD STYLE -01 ONLY, -03 THRU -50 POS) (MATES WITH SFSS/SFSD -SR & -DR ONLY) (SEE FIG 11, SHT 4)
- RE2: RIGHT ANGLE ELEVATED .093 PCB (USE TFM-XX-D-01-RE, NOT AVAILABLE WITHOUT -WT, AVAILABLE IN LEAD STYLE -01 ONLY, -03 THRU -50 POS) (MATES WITH SFSS/SFSD -SR & -DR ONLY) (SEE FIG 11, SHEET 4)
- SN: SOLDER NAIL FOR .062 BOARD (TFM-XX-D-01-SN AND WT-27-01-T) (SEE FIG 12, SHT 3) (ONLY AVAILABLE WITH -02 LEAD STYLE) (NOT AVAILABLE WITH OPTIONS -A, -LC, -RA, -SA, -WT, -RE1 OR -RE2)
- SN2: SOLDER NAIL FOR .093 BOARD (TFM-XX-D-01-SN AND WT-27-02-T) (SEE FIG 12, SHT 3) (ONLY AVAILABLE WITH -02 LEAD STYLE) (NOT AVAILABLE WITH OPTIONS -A, -LC, -RA, -SA, -WT, -RE1 OR -RE2)
- DS: DUAL SCREW DOWN FOR .062 BOARD (SEE FIG 18, SHT 5) (ONLY AVAILABLE WITH -01 & -02 LEAD STYLE) (NOT AVAILABLE WITH OPTIONS -A, -LC, -P, -RA, -TR, -SA, -K, -WT, -RE1, -RE2, -SN, -SN2) (-01 LEAD STYLE USES TFM-XX-D-01-DSL & T1-M2-4-VSFM-T, 02 LEAD STYLE USES TFM-XX-D-01-DSA & T1-M2-4-VSFM-T)

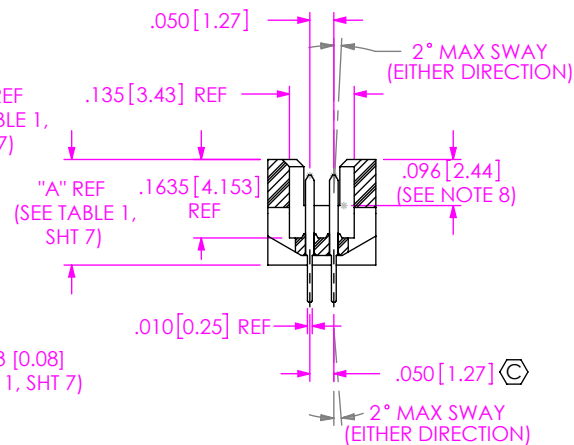
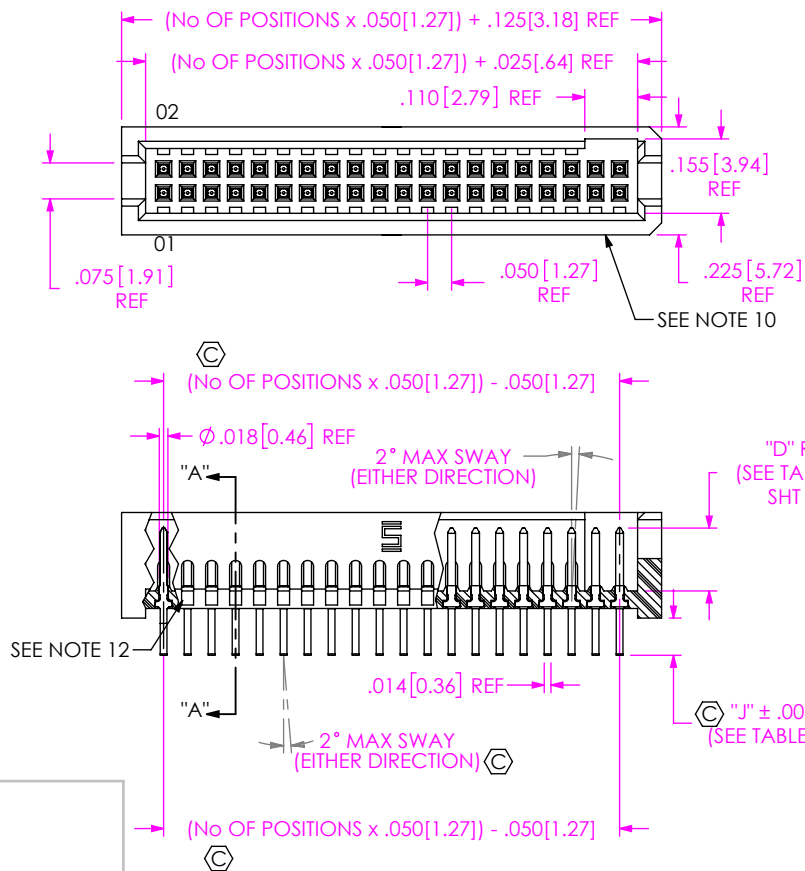

SECTION "A"-"A"

UNLESS OTHERWISE SPECIFIED, DIMENSIONS ARE IN INCHES.
TOLERANCES ARE:
DECIMALS ANGLES
.XX: \pm .01 [0.3]
.XXX: \pm .005 [0.13]
.XXXX: \pm .0020 [0.051]

PROPRIETARY NOTE
THIS DOCUMENT CONTAINS CONFIDENTIAL AND PROPRIETARY INFORMATION AND ALL DESIGN, MANUFACTURING, REPRODUCTION, USE, PATENT RIGHTS AND SALES RIGHTS ARE EXPRESSLY RESERVED BY SAMTEC, INC. THIS DOCUMENT SHALL NOT BE DISCLOSED, IN WHOLE OR PART, TO ANY UNAUTHORIZED PERSON OR ENTITY NOR REPRODUCED, TRANSFERRED OR INCORPORATED IN ANY OTHER PROJECT IN ANY MANNER WITHOUT THE EXPRESS WRITTEN CONSENT OF SAMTEC, INC.

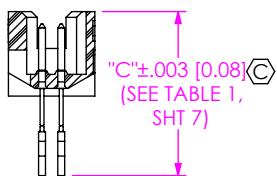

IN-PROCESS

FIG 1 THROUGH HOLE -01, -03, -11, -13, -21, -23, -31

MATERIAL: DO NOT SCALE DRAWING SHEET SCALE: 2.5:1
INSULATOR: LCP, UL 94-V0
COLOR: BLACK
TERMINAL: PHOSPHOR BRONZE

DESCRIPTION: .050 X .050 TERMINAL STRIP
DWG. NO. TFM-1XX-XX-XXX-D-XXX
BY: garyp 11/5/2014 SHEET 1 OF 7



520 PARK EAST BLVD, NEW ALBANY, IN 47150
PHONE: 812-944-6733 FAX: 812-948-5047
e-Mail info@SAMTEC.com code 55322

REVISION FG

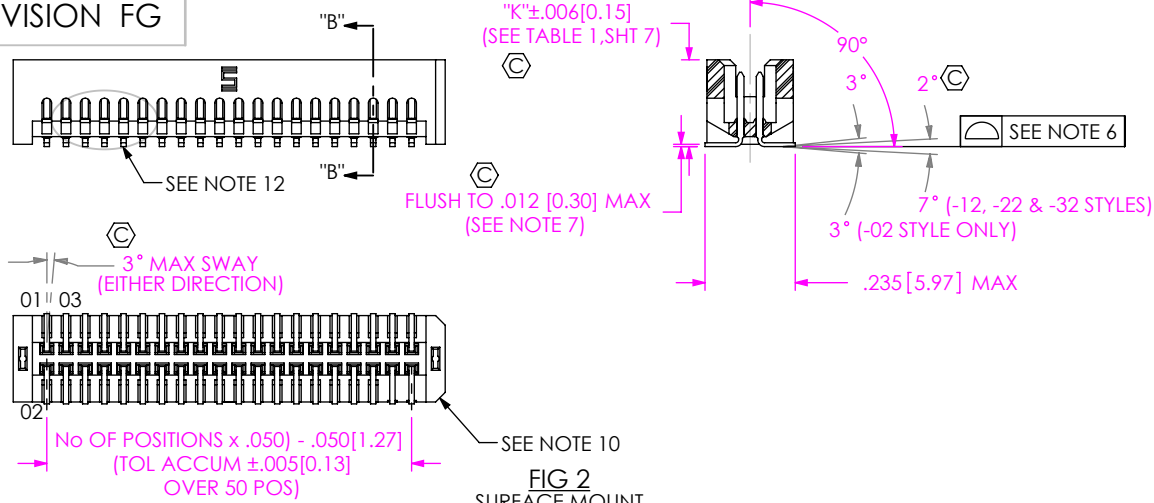

FIG 2
SURFACE MOUNT
-02, -12, -22, -32
DIFFERENT AS SHOWN, OTHERWISE SAME AS FIG 1

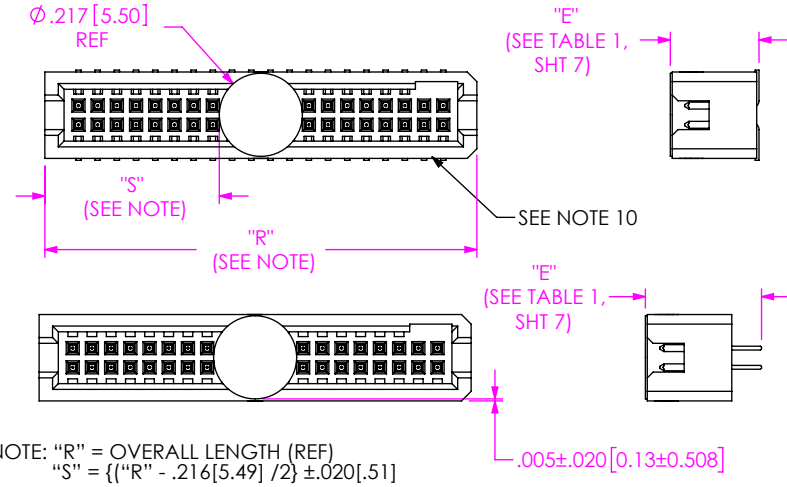

FIG 3
-K: POLYIMIDE FILM PAD

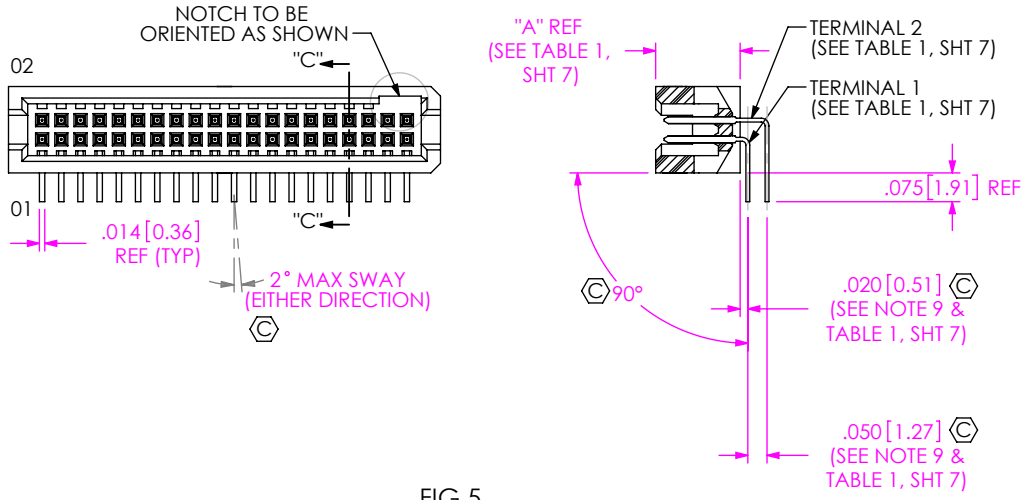

FIG 5
-RA OPTION
DIFFERENT AS SHOWN, OTHERWISE SAME AS FIG 1

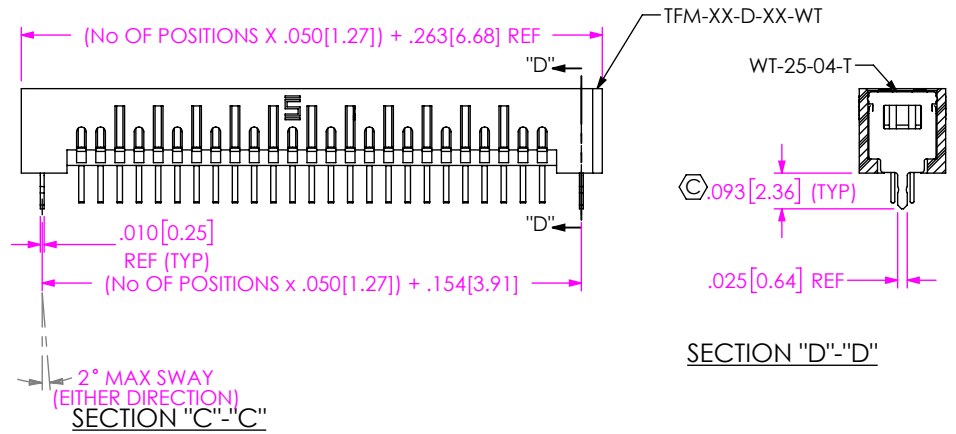
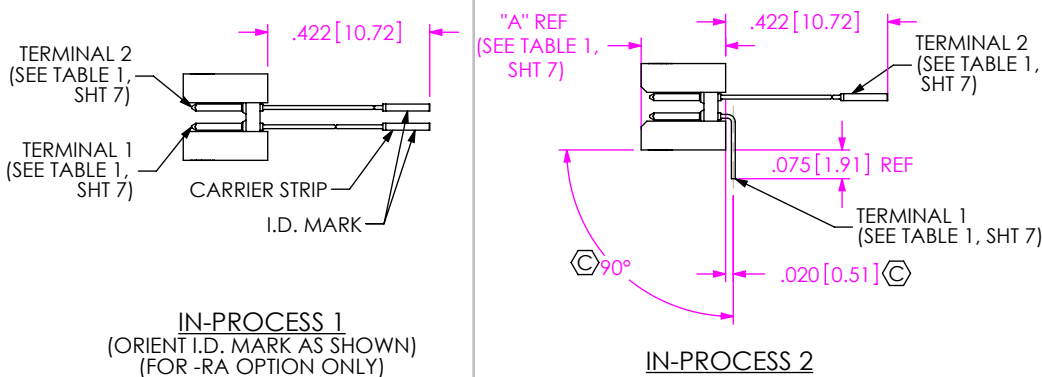

FIG 6
-WT OPTION
DIFFERENT AS SHOWN, OTHERWISE SAME AS FIG 1



F:\DWG\MISC\MKTG\TFM-1XX-XX-XXX-D-XXX-MKT.SLDDRW

PROPRIETARY NOTE
THIS DOCUMENT CONTAINS CONFIDENTIAL AND PROPRIETARY INFORMATION AND ALL DESIGN, MANUFACTURING, REPRODUCTION, USE, PATENT RIGHTS AND SALES RIGHTS ARE EXPRESSLY RESERVED BY SAMTEC, INC. THIS DOCUMENT SHALL NOT BE DISCLOSED, IN WHOLE OR PART, TO ANY UNAUTHORIZED PERSON OR ENTITY NOR REPRODUCED, TRANSFERRED OR INCORPORATED IN ANY OTHER PROJECT IN ANY MANNER WITHOUT THE EXPRESS WRITTEN CONSENT OF SAMTEC, INC.

DO NOT SCALE DRAWING

SHEET SCALE: 2:1

samtec

520 PARK EAST BLVD, NEW ALBANY, IN 47150
PHONE: 812-944-6733 FAX: 812-948-5047
e-Mail: info@SAMTEC.com code 55322

DESCRIPTION:
.050 X .050 TERMINAL STRIP

DWG. NO. TFM-1XX-XX-XXX-D-XXX

BY: garyp 11/5/2014 SHEET 2 OF 7

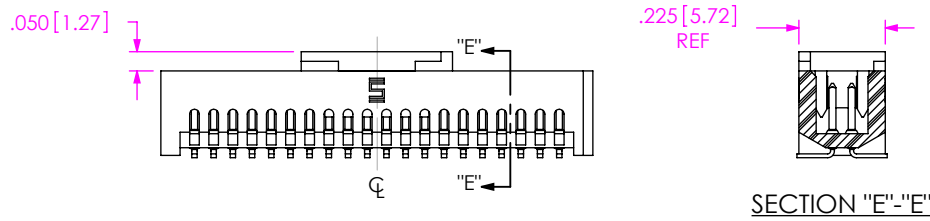
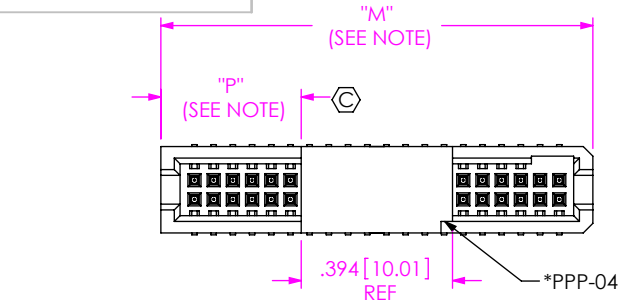

NOTE: "M" = (No. OF POSITIONS X .050[1.27]) + .125[3.18] (REF)
 WITH -WT "M" = (No. OF POSITIONS X .050[1.27]) + .263[6.68] (REF)
 "P" = {"M" - .394[10.01]} / 2 ± .020[.51]

* NOTCH ON PAD TO BE ON SAME END AS THE NOTCH IN THE TFM BODY

FIG 7
 -P OPTION
 DIFFERENT AS SHOWN, OTHERWISE SAME AS FIG 1
 (PAD TO BE POSITIONED ON C.L. AS SHOWN)

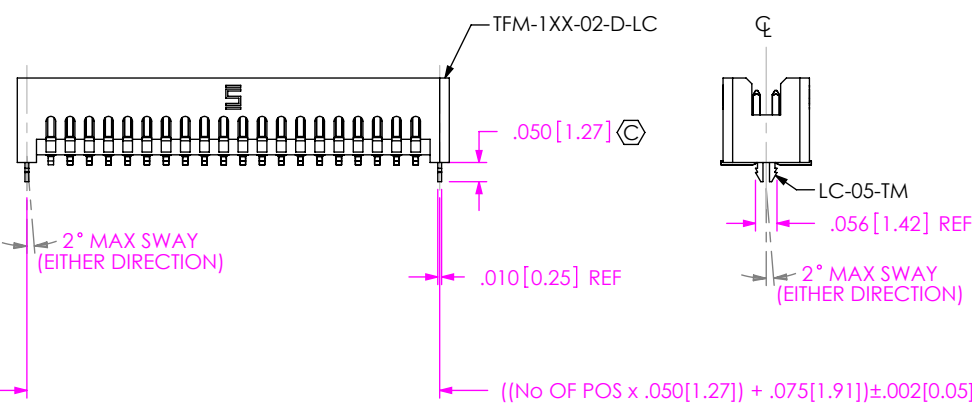

FIG 10
 -LC OPTION
 DIFFERENT AS SHOWN, OTHERWISE SAME AS FIG 1
 (NOT AVAILABLE ON -RA)

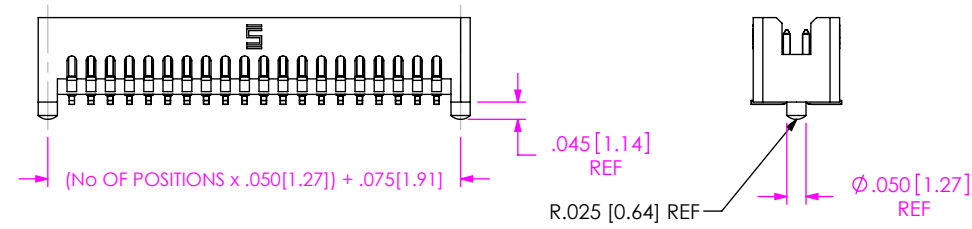

FIG 8
 -A OPTION
 DIFFERENT AS SHOWN, OTHERWISE SAME AS FIG 1

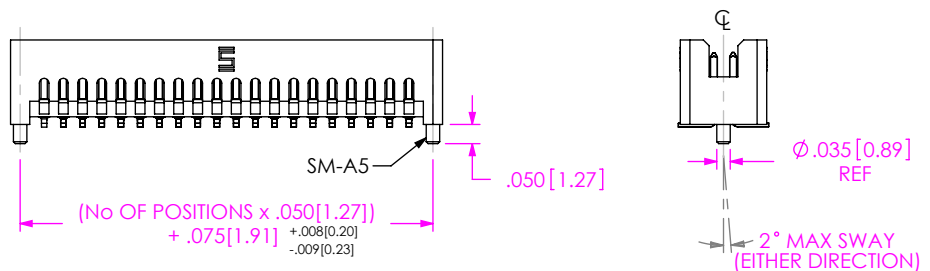

FIG 9
 -SA OPTION: STAKED ALIGNMENT PIN
 DIFFERENT AS SHOWN, OTHERWISE SAME AS FIG 1

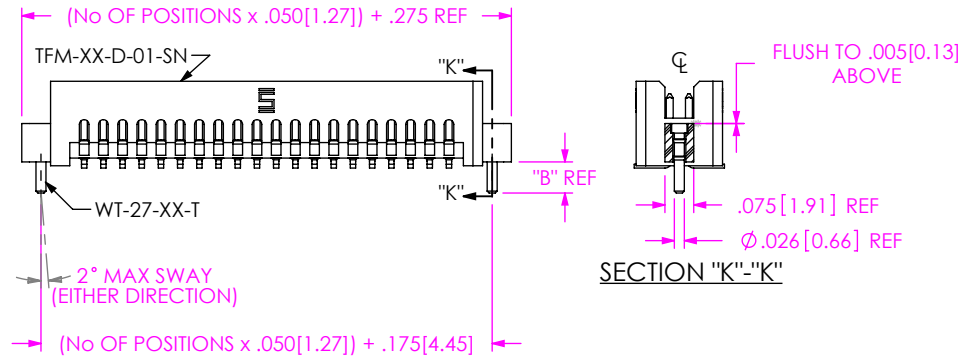

FIG 12
 -SNX: SOLDER NAIL
 DIFFERENT AS SHOWN, OTHERWISE SAME AS FIG 1

TABLE 4	
OPTION	"B"
-SN	.081 2.06
-SN2	.115 2.92

F:\DWG\MISC\MKTG\TFM-1XX-XX-XXX-D-XXX-MKT.SLDRW

PROPRIETARY NOTE
 THIS DOCUMENT CONTAINS CONFIDENTIAL AND PROPRIETARY INFORMATION AND ALL DESIGN, MANUFACTURING, REPRODUCTION, USE, PATENT RIGHTS AND SALES RIGHTS ARE EXPRESSLY RESERVED BY SAMTEC, INC. THIS DOCUMENT SHALL NOT BE DISCLOSED, IN WHOLE OR PART, TO ANY UNAUTHORIZED PERSON OR ENTITY NOR REPRODUCED, TRANSFERRED OR INCORPORATED IN ANY OTHER PROJECT IN ANY MANNER WITHOUT THE EXPRESS WRITTEN CONSENT OF SAMTEC, INC.

DO NOT SCALE DRAWING
 SHEET SCALE: 2:1



520 PARK EAST BLVD, NEW ALBANY, IN 47150
 PHONE: 812-944-6733 FAX: 812-948-5047
 e-Mail info@SAMTEC.com code 55322

DESCRIPTION: .050 X .050 TERMINAL STRIP
 DWG. NO. TFM-1XX-XX-XXX-D-XXX
 BY: garyp 11/5/2014 SHEET 3 OF 7

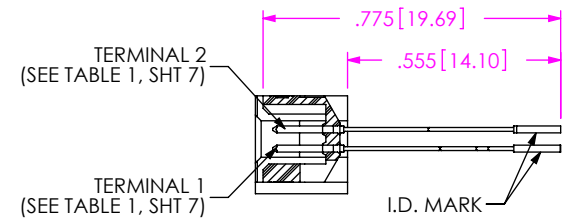
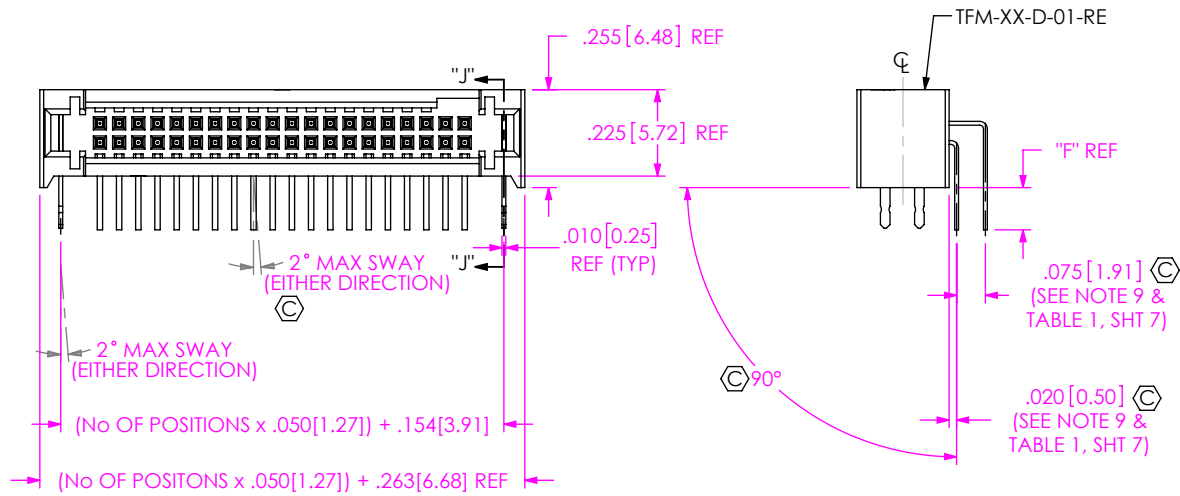
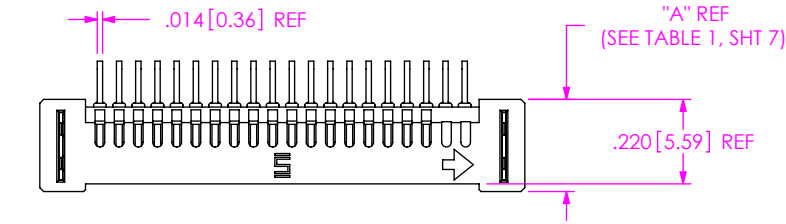

IN-PROCESS 1
(ORIENT I.D. MARK AS SHOWN)
(FOR -RA OPTION ONLY)

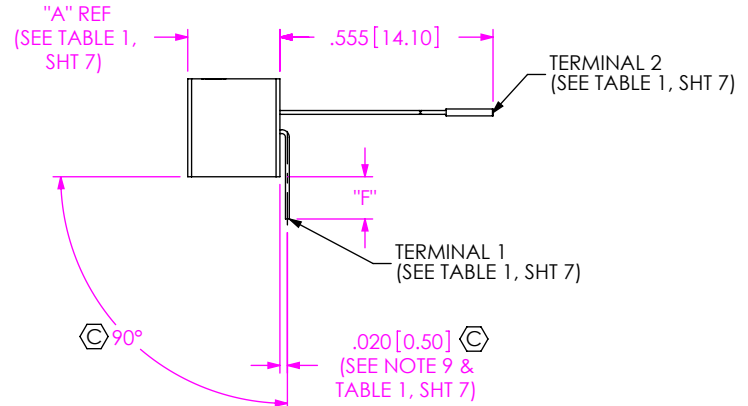

IN-PROCESS 2

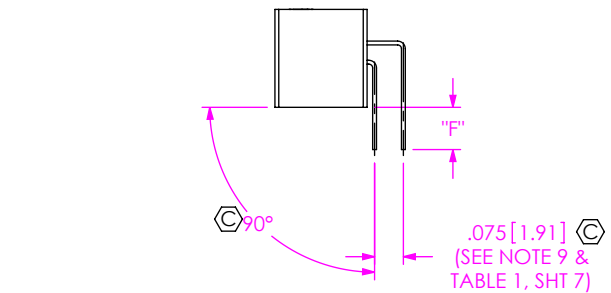

IN-PROCESS 3

F:\DWG\MISC\MKTG\TFM-1XX-XX-XXX-D-XXX-MKT.SLDDRW

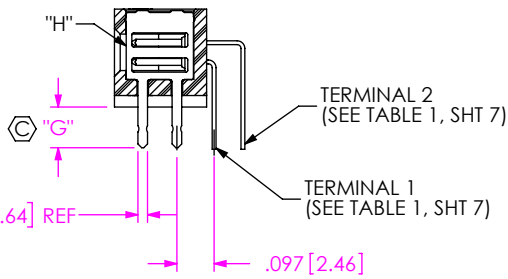

SECTION "J"-"J"

TABLE 3			
LEAD STYLE	"F"	"G"	"H"
-01-RE1	.078 [1.98]	.074 [1.88]	WT-81-01-T
-01-RE2	.110 [2.79]	.106 [2.69]	WT-81-02-T

FIG 11
-REX: RIGHT ANGLE ELEVATED
TFM-120-XX-XXX-D-RE2 SHOWN
DIFFERENT AS SHOWN, OTHERWISE SAME AS FIG 1

PROPRIETARY NOTE
THIS DOCUMENT CONTAINS CONFIDENTIAL AND PROPRIETARY INFORMATION AND ALL DESIGN, MANUFACTURING, REPRODUCTION, USE, PATENT RIGHTS AND SALES RIGHTS ARE EXPRESSLY RESERVED BY SAMTEC, INC. THIS DOCUMENT SHALL NOT BE DISCLOSED, IN WHOLE OR PART, TO ANY UNAUTHORIZED PERSON OR ENTITY NOR REPRODUCED, TRANSFERRED OR INCORPORATED IN ANY OTHER PROJECT IN ANY MANNER WITHOUT THE EXPRESS WRITTEN CONSENT OF SAMTEC, INC.

DO NOT SCALE DRAWING

SHEET SCALE: 2:1



520 PARK EAST BLVD. NEW ALBANY, IN 47150
PHONE: 812-944-6733 FAX: 812-948-5047
e-Mail info@SAMTEC.com code 53322

DESCRIPTION:
.050 X .050 TERMINAL STRIP

DWG. NO. TFM-1XX-XX-XXX-D-XXX

BY: garyp 11/5/2014 SHEET 4 OF 7

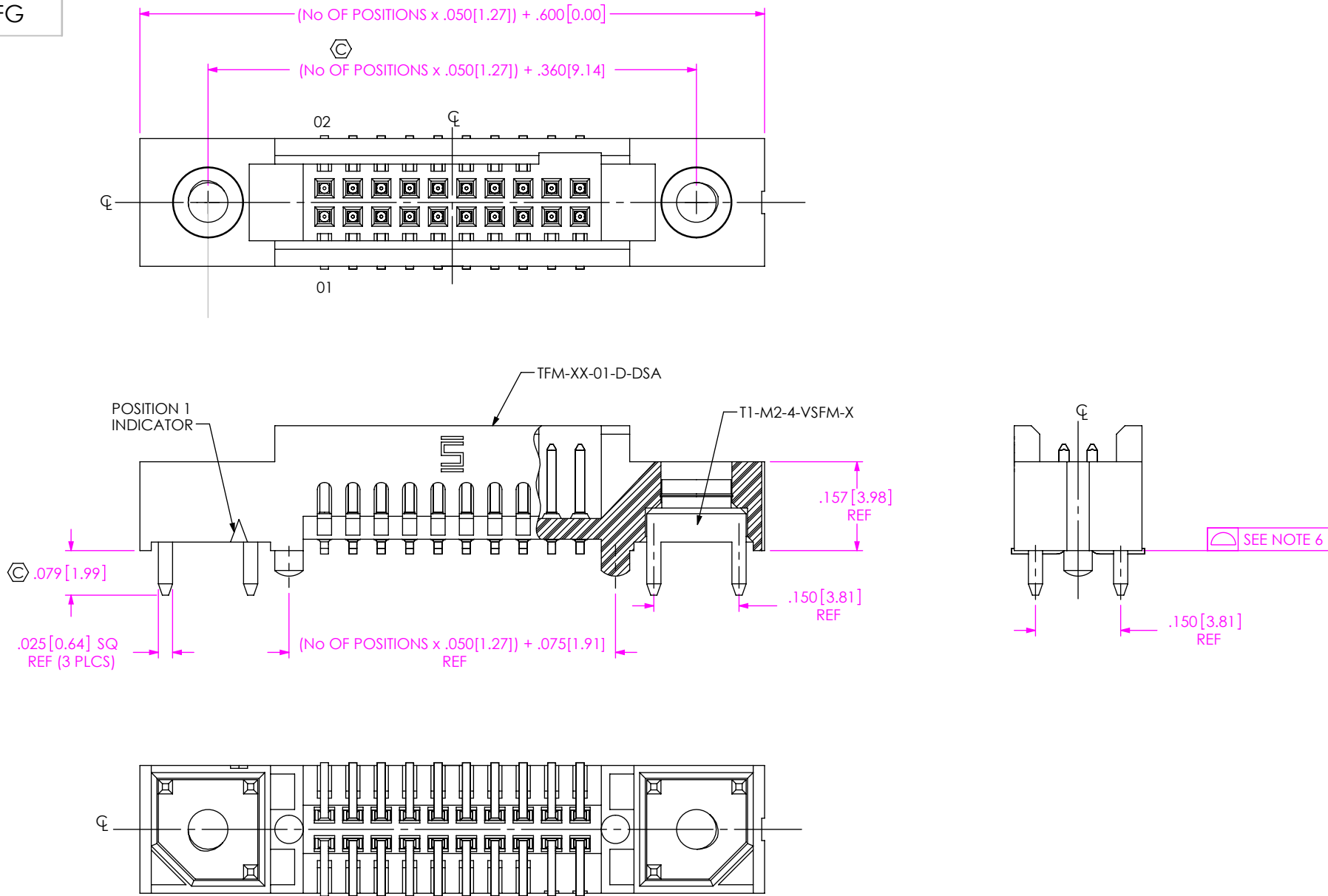

FIG 18
 -DS: DUAL SCREW DOWN
 TFM-110-02-XXX-D-DS SHOWN
 DIFFERENT AS SHOWN, OTHERWISE SAME AS FIG 1

F:\DWG\MISC\MKTG\TFM-1XX-XX-XXX-D-XXX-MKT.SLDDRW

PROPRIETARY NOTE
 THIS DOCUMENT CONTAINS CONFIDENTIAL AND PROPRIETARY INFORMATION AND ALL DESIGN, MANUFACTURING, REPRODUCTION, USE, PATENT RIGHTS AND SALES RIGHTS ARE EXPRESSLY RESERVED BY SAMTEC, INC. THIS DOCUMENT SHALL NOT BE DISCLOSED, IN WHOLE OR PART, TO ANY UNAUTHORIZED PERSON OR ENTITY NOR REPRODUCED, TRANSFERRED OR INCORPORATED IN ANY OTHER PROJECT IN ANY MANNER WITHOUT THE EXPRESS WRITTEN CONSENT OF SAMTEC, INC.

DO NOT SCALE DRAWING
 SHEET SCALE: 2:1



520 PARK EAST BLVD, NEW ALBANY, IN 47150
 PHONE: 812-944-6733 FAX: 812-948-5047
 e-Mail info@SAMTEC.com code 55322

DESCRIPTION:	.050 X .050 TERMINAL STRIP	
DWG. NO.	TFM-1XX-XX-XXX-D-XXX	
BY:	garyp	11/5/2014
		SHEET 5 OF 7

PARTS TO BE PACKAGED IN TUBES AS SHOWN

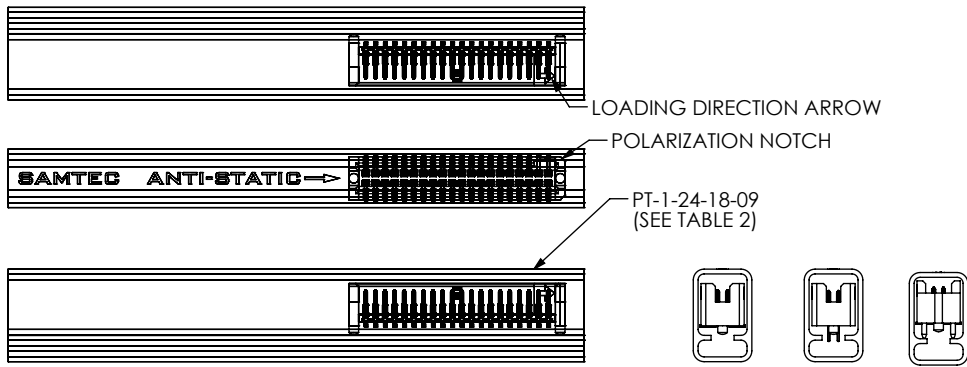

FIG 13
PT-1-24-18-09

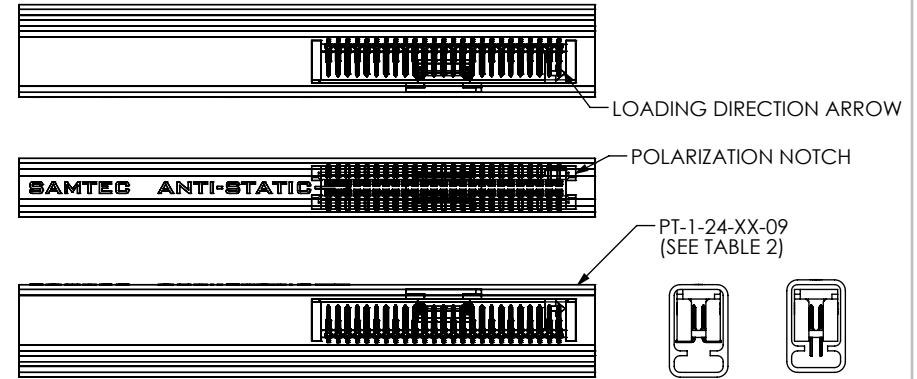

FIG 14
PT-1-24-XX-09

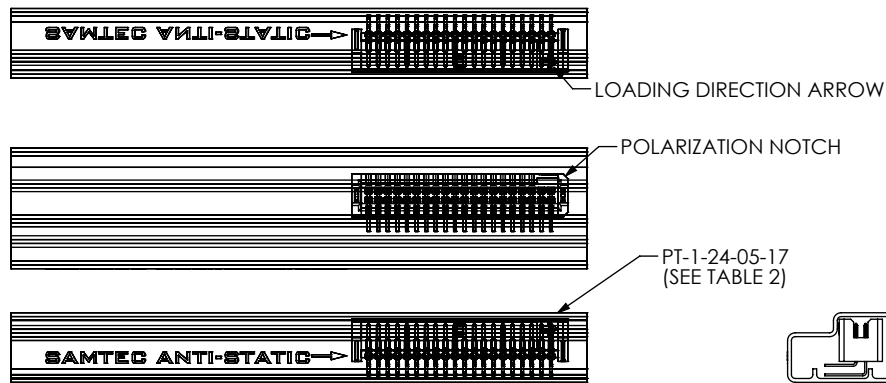

FIG 15
PT-1-24-05-17

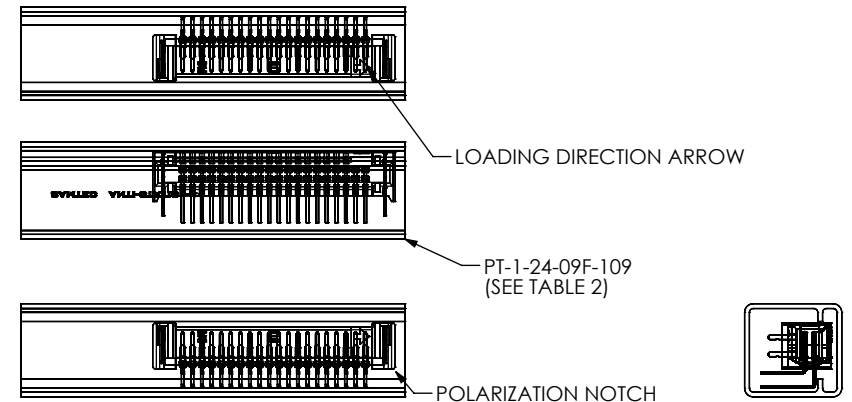

FIG 16
PT-1-24-09F-109

TABLE 2

LEAD STYLE	PACKAGING TUBE	PLUG
-RA (ALL LEAD STYLES)	PT-1-24-05-17	TP-07
-REX	PT-1-24-09F-109	TP-29
-01, -01-A, -01-LC, -01-WT, -01-A-K, -02, -02-A, -02-A-K, -02-LC, -02-SN	PT-FTSH002-DV-A-P-M	TP-03
-12 (ALL OPTIONS), -22-K, -22, -22-A, -22-A-K, -22-LC, -22-LC-K	PT-1-24-04-09	TP-07
-02-A-P, -02-K, -02-LC-K, -02-LC-P, -02-P, -02-WT, -02-WT-K	PT-1-24-18-09	TP-09
-01-K, -01-LC-P, -01-A-P, -01-WT-P, -01-WT-K, -11, -11-A, -11-LC, -11-K, -11-LC-K, -11-A-K		
-03 (ALL OPTIONS)		
-13, -13-A, -13-LC, -13-K, -13-LC-K, -13-A-K	PT-1-24-02-09	TP-07
-01-DS, -02-DS		
-31-A-K, -31-A-P, -31-LC-P, -31-P, -32, -32-K, -32-A, -32-A-K, -32-A-P, -32-LC-K, -32-LC-P, -32-P, -32-LC		
-31, -21-P, -22-P, -31-LC, -21-A-P, -21-LC-P, -22-LC-P, -22-A-P, -31-A, -13-P, -13-LC-P, -13-A-P, -21, -23, -23-P, -23-A-P,	PT-1-24-05-09	TP-07
-11-P, -11-LC-P, -11-A-P, -21-K, -21-A, -21-LC, -21-A-K, -21-LC-K, -23-K, -23-A, -23-A-K, -23-LC, -23-LC-K	PT-1-24-20-09	TP-07

NOTE:

1. PARTS TO BE PACKAGED WITH THE LOADING DIRECTION ARROW POINTED IN SAME DIRECTION AS THE ARROW ON TUBE.
2. A PART WITH -SA OPTION WILL USE THE SAME TUBE AS THE CORRESPONDING PART WITH THE -A OPTION

F:\DWG\MISC\MKTG\TFM-1XX-XX-XXX-D-XXX-MKT.SLDDRW

PROPRIETARY NOTE

THIS DOCUMENT CONTAINS CONFIDENTIAL AND PROPRIETARY INFORMATION AND ALL DESIGN, MANUFACTURING, REPRODUCTION, USE, PATENT RIGHTS AND SALES RIGHTS ARE EXPRESSLY RESERVED BY SAMTEC, INC. THIS DOCUMENT SHALL NOT BE DISCLOSED, IN WHOLE OR PART, TO ANY UNAUTHORIZED PERSON OR ENTITY NOR REPRODUCED, TRANSFERRED OR INCORPORATED IN ANY OTHER PROJECT IN ANY MANNER WITHOUT THE EXPRESS WRITTEN CONSENT OF SAMTEC, INC.

DO NOT SCALE DRAWING

SHEET SCALE: 2:1



520 PARK EAST BLVD, NEW ALBANY, IN 47150
PHONE: 812-944-6733 FAX: 812-948-5047
e-Mail: info@SAMTEC.com code 55322

DESCRIPTION: .050 X .050 TERMINAL STRIP

DWG. NO. TFM-1XX-XX-XXX-D-XXX

BY: garyp 11/5/2014 SHEET 6 OF 7

TABLE 1									
LEAD STYLE	BODY	"A"	TERMINAL 1	TERMINAL 2	"C"	"D"	"E"	"J"	"K"
-01	TFM-XX-D-01-XX	.2200 [5.588]	T-1R16-01-XX-2	N/A	.428 [10.87]	.131 [3.33]	.303 [7.70]	.078 [1.98]	N/A
-11	TFM-XX-D-02-XX	.2900 [7.366]	T-1R20-03-XX	N/A	.645 [16.38]	.139 [3.53]	.375 [9.53]	.080 [2.03]	N/A
-21	TFM-XX-D-03-XX	.3600 [9.144]	T-1R20-04-XX	N/A	.645 [16.38]	.139 [3.53]	N/A	.080 [2.03]	N/A
-31	TFM-XX-D-04-XX	.4350 [11.049]	T-1R20-02-XX	N/A	.645 [16.38]	.139 [3.53]	.520 [13.21]	.080 [2.03]	N/A
-02	TFM-XX-D-01-XX	.2200 [5.588]	T-1R16-01-XX-2	N/A	.428 [10.87]	.131 [3.33]	.231 [5.87]	N/A	.226 [5.74]
-12	TFM-XX-D-02-XX	.2900 [7.366]	T-1R20-03-XX	N/A	.645 [16.38]	.139 [3.53]	.301 [7.65]	N/A	.296 [7.52]
-22	TFM-XX-D-03-XX	.3600 [9.144]	T-1R20-04-XX	N/A	.645 [16.38]	.139 [3.53]	.371 [9.42]	N/A	.366 [9.30]
-32	TFM-XX-D-04-XX	.4350 [11.049]	T-1R20-02-XX	N/A	.645 [16.38]	.139 [3.53]	.446 [11.33]	N/A	.441 [11.20]
-01-RA	TFM-XX-D-01-XX	.2200 [5.588]	T-1R16-02-XX	T-1R16-03-XX	N/A	.142 [3.59]	N/A	N/A	N/A
-01-RE1	TFM-XX-D-01-RE	.2400 [6.096]	T-1R16-06-XX	T-1R16-07-XX	N/A	.139 [3.52]	N/A	N/A	N/A
-01-RE2	TFM-XX-D-01-RE	.2400 [6.096]	T-1R16-08-XX	T-1R16-09-XX	N/A	.139 [3.52]	N/A	N/A	N/A
-03	TFM-XX-D-01-XX	.2200 [5.588]	T-1R16-10-XX	N/A	.645 [16.38]	.139 [3.53]	.336 [8.53]	.111 [2.82]	N/A
-13	TFM-XX-D-02-XX	.2900 [7.366]	T-1R20-05-XX	N/A	.645 [16.38]	.139 [3.53]	.406 [10.31]	.111 [2.82]	N/A
-23	TFM-XX-D-03-XX	.3600 [9.144]	T-1R20-06-XX	N/A	.645 [16.38]	.139 [3.53]	.476 [12.09]	.111 [2.82]	N/A

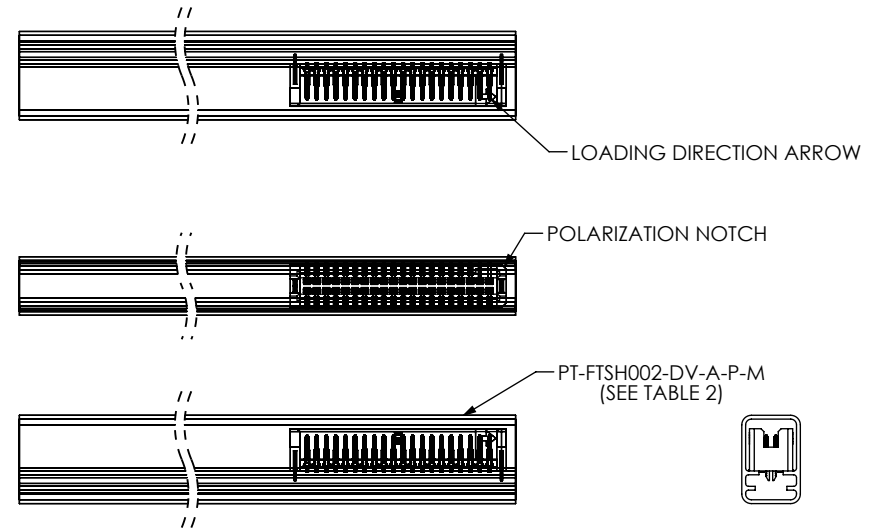
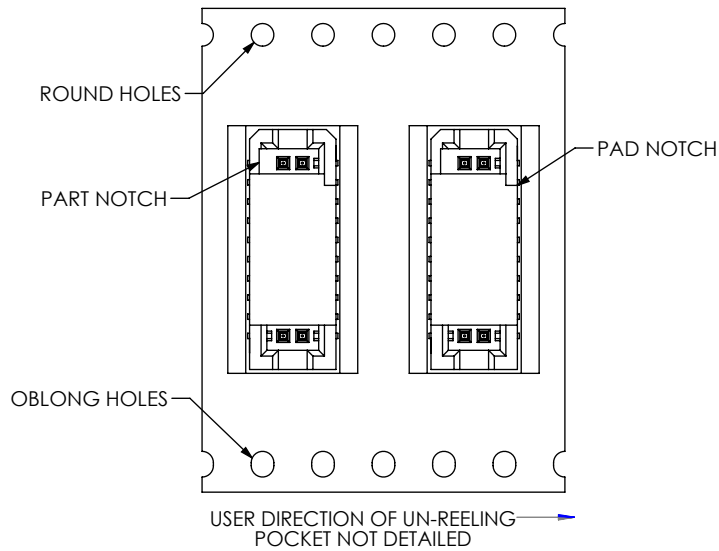

F:\DWG\MISC\MKTG\TFM-1XX-XX-XXX-D-XXX-MKT.SLDDRW

PROPRIETARY NOTE
 THIS DOCUMENT CONTAINS CONFIDENTIAL AND PROPRIETARY INFORMATION AND ALL DESIGN, MANUFACTURING, REPRODUCTION, USE, PATENT RIGHTS AND SALES RIGHTS ARE EXPRESSLY RESERVED BY SAMTEC, INC. THIS DOCUMENT SHALL NOT BE DISCLOSED, IN WHOLE OR PART, TO ANY UNAUTHORIZED PERSON OR ENTITY NOR REPRODUCED, TRANSFERRED OR INCORPORATED IN ANY OTHER PROJECT IN ANY MANNER WITHOUT THE EXPRESS WRITTEN CONSENT OF SAMTEC, INC.

DO NOT SCALE DRAWING

SHEET SCALE: 2:1

samtec
 520 PARK EAST BLVD, NEW ALBANY, IN 47150
 PHONE: 812-944-6733 FAX: 812-948-5047
 e-Mail info@SAMTEC.com code 55322

DESCRIPTION:
 .050 X .050 TERMINAL STRIP

DWG. NO.
TFM-1XX-XX-XXX-D-XXX

BY: garyp 11/5/2014 SHEET 7 OF 7

X-ON Electronics

Largest Supplier of Electrical and Electronic Components

Click to view similar products for [Headers & Wire Housings](#) category:

Click to view products by [Samtec](#) manufacturer:

Other Similar products are found below :

[95000-104TRLF](#) [10135584-644402LF](#) [DF62W-EP2022PCA](#) [95000-106TRLF](#) [DF62W-2022SCA](#) [DF62W-EP2022PC](#) [2203348](#) [DF62W-2022SC](#) [1084018](#) [1029039](#) [1084017](#) [802-10-012-10-002000](#) [1112640](#) [1112639](#) [000-34000](#) [0009482033](#) [0009507031](#) [57102-S06-03LF](#) [57202-S52-04LF](#) [PCN6-15S-2.5E](#) [0039019024](#) [58102-G61-06LF](#) [582553-1](#) [0009508121](#) [0022285053](#) [0050291907](#) [018731A](#) [LY20-4P-DT1-P1E-BR](#) [02.125.8002.8](#) [60101931](#) [60598-1 \(Cut Strip\)](#) [M1625-3R/100](#) [61062-3](#) [61082-181009](#) [636-1427](#) [638009-1](#) [641938-9](#) [641991-4](#) [644168-1](#) [647662-1](#) [65039-019ELF](#) [65817-002LF](#) [65817-015LF](#) [65863-015LF](#) [66207-023LF](#) [67016-026LF](#) [67046-001LF](#) [67095-007LF](#) [67230-005LF](#) [68002-116](#)