

SYMBOL DEFINITION		TOTAL NO OF INSPECTIONS REQUIRED	NO MISSING SYMBOL NUMBER
A DIMENSION WITHOUT AN INSPECTION REPORT SYMBOL ( ) DOES NOT REQUIRE INSPECTION. IT MAY BE CONTROLLED ON THE INDIVIDUAL COMPONENT DRAWING.		20	
	LAST NO. USED	15	

DWG STATUS				REVISION HISTORY				AUTH		DR		AP/VD	
DATE	STG	REV	N/P	CHG	ZONE								
08JUL02	R	02	-	-		CLEARED REV COLUMN#12010717 - MAT'L SPEC WAS R0067547 PA6-BLK; 12015092 - MAT'L SPEC WAS R0064530 PA6-RED; 12015460 - MAT'L SPEC WAS R0065644 PA6-BLU				226196	JBR	EVO	RC
16JUL07	R	03	-	-		ADDED NOTE 8: UPDATED MATERIAL DESCRIPTION				401863	PJC	PJC	SS

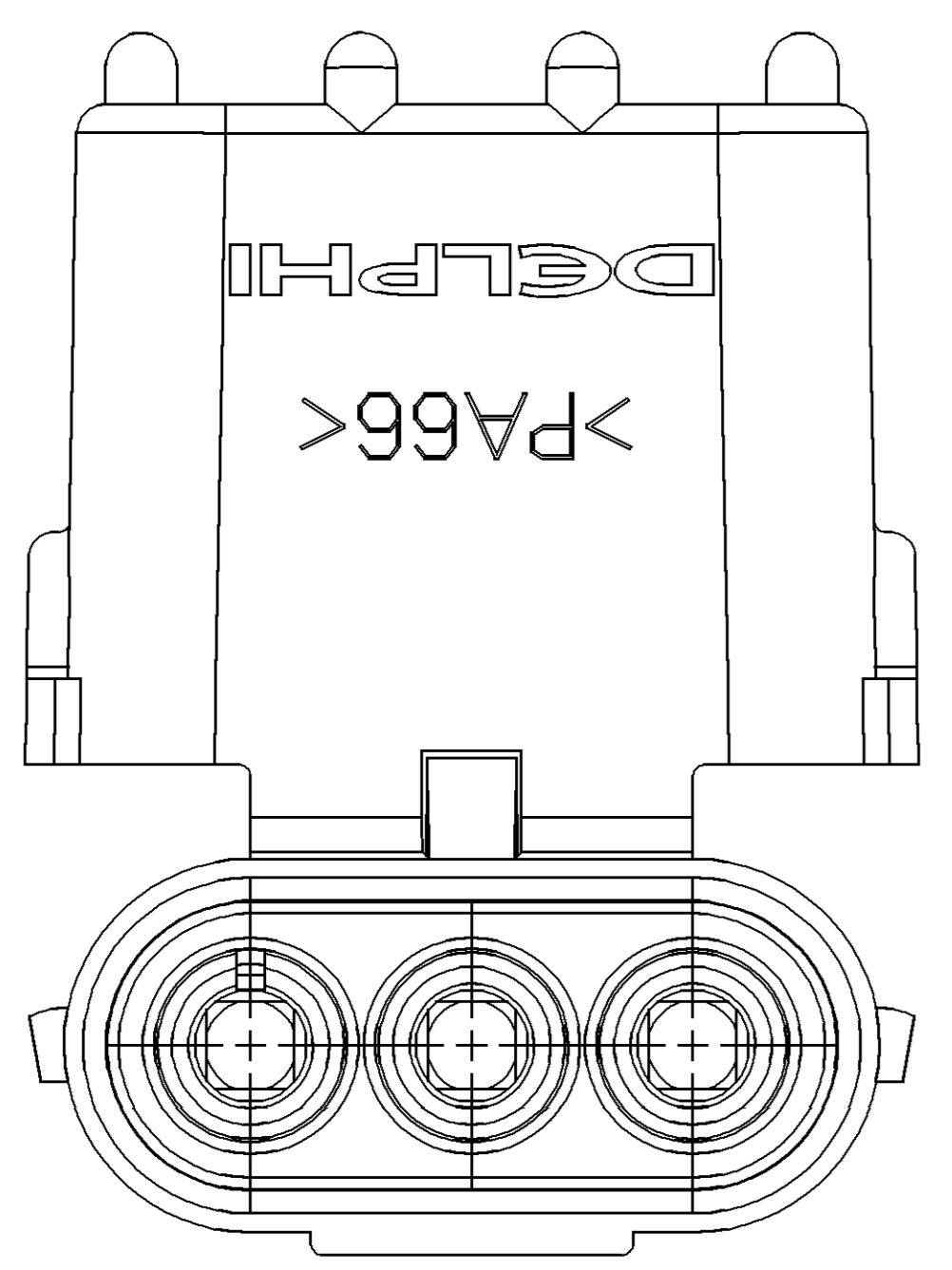

TYPE 102  
SAME AS TYPE 101  
EXCEPT AS SHOWN

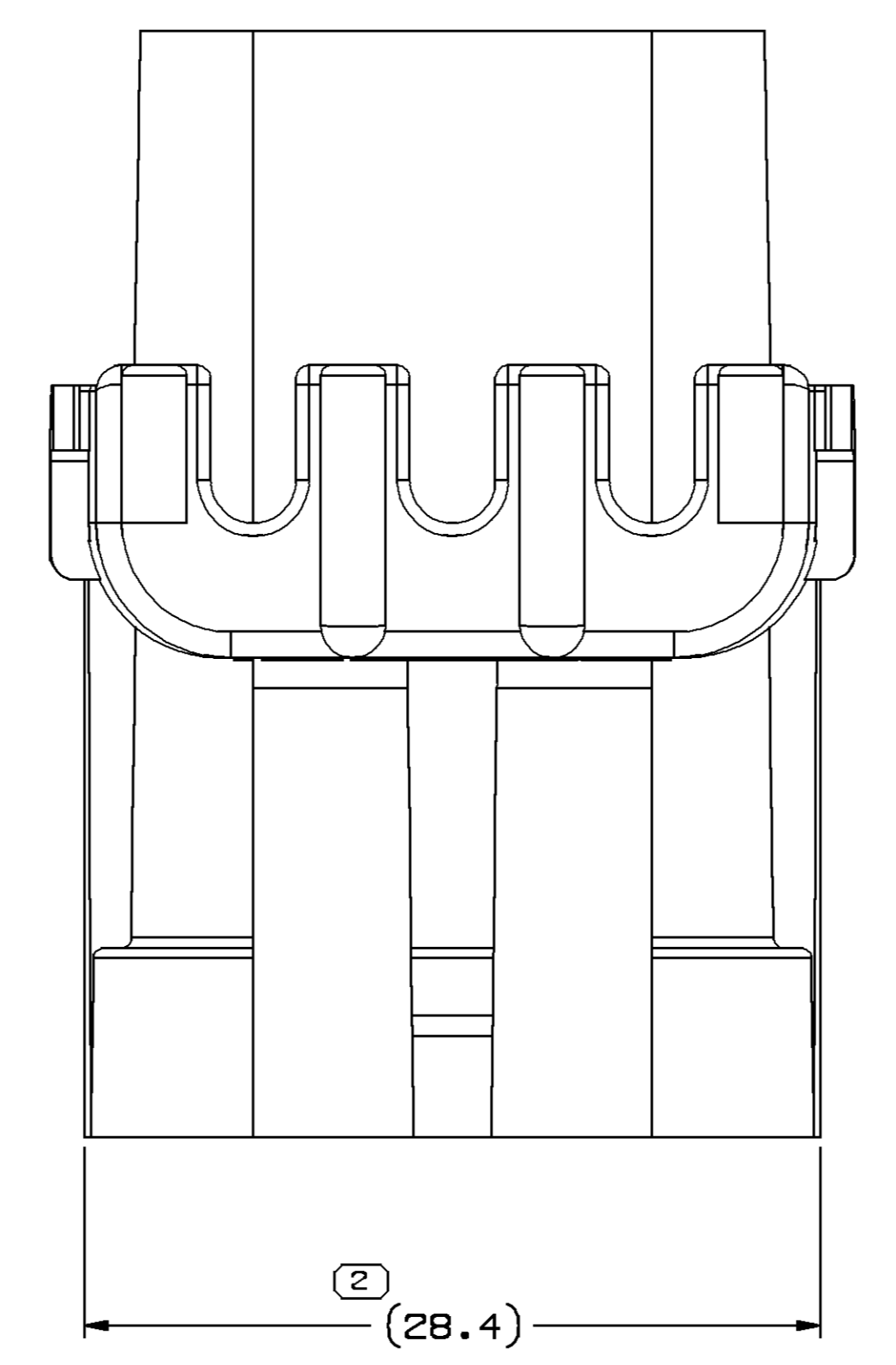
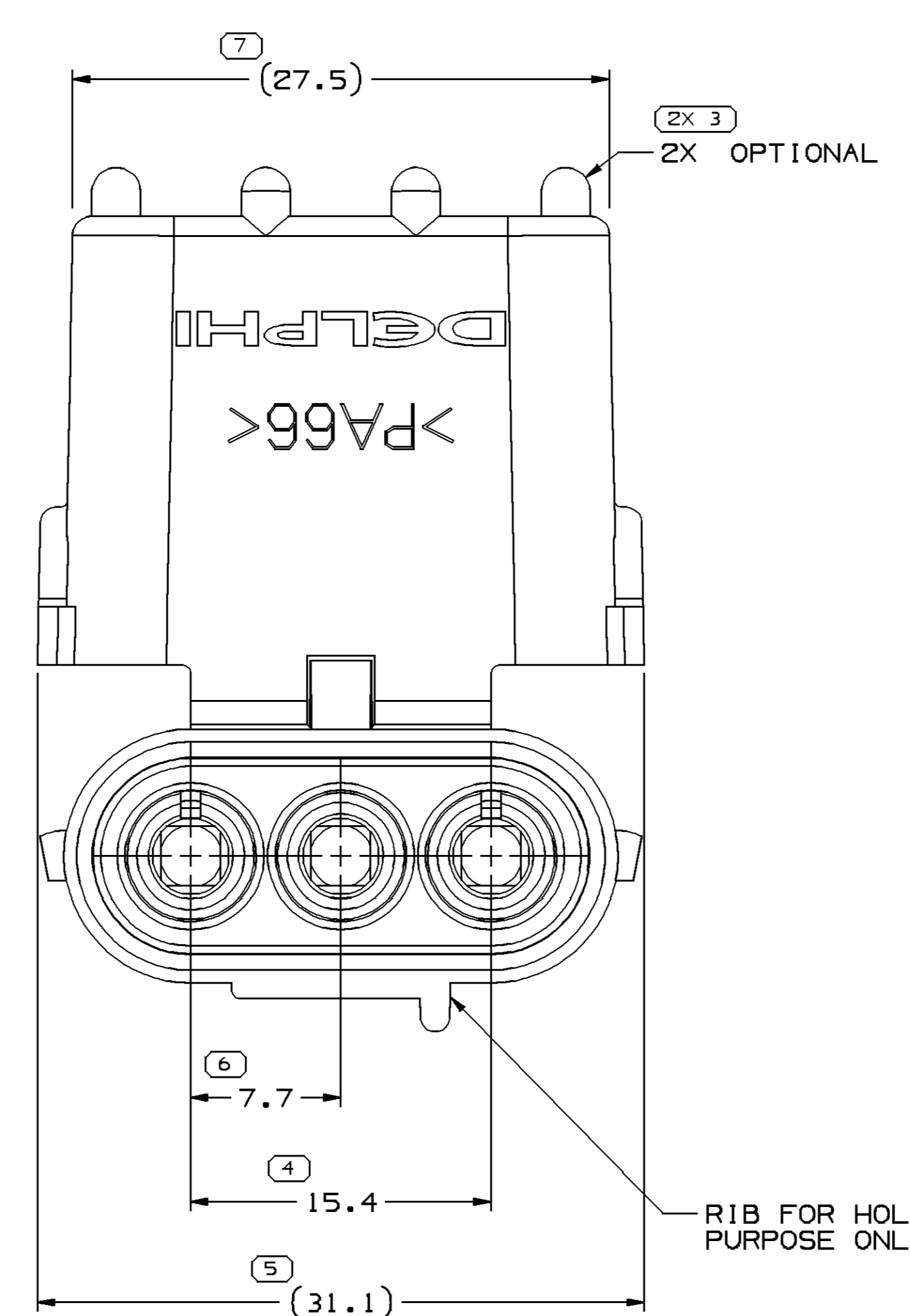

TYPE 101

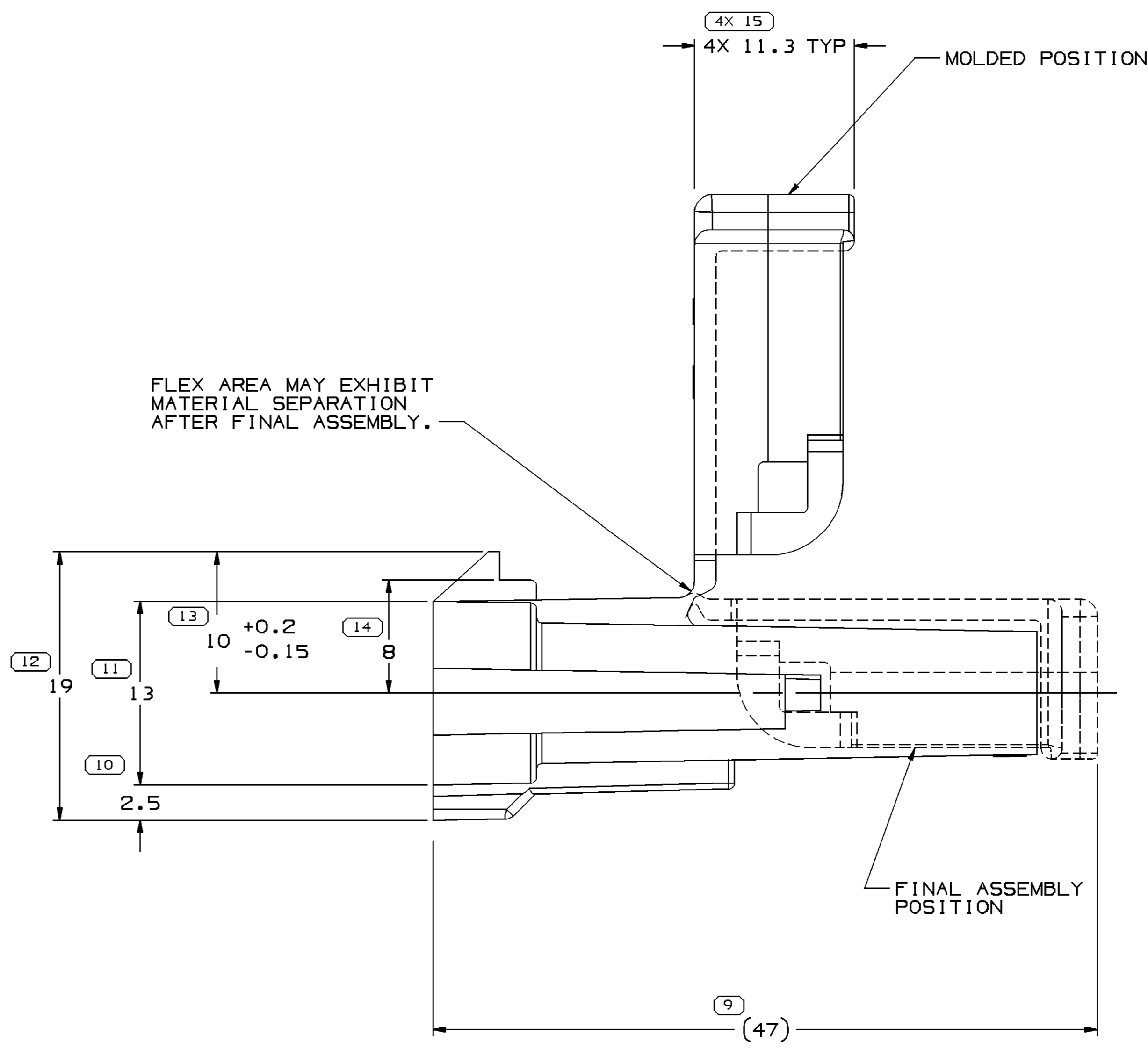

INDEX CODE  
-100-  
(ALSO SEE HAND BOOK)

INDEX CODE  
-101-  
(ALSO SEE HAND BOOK)

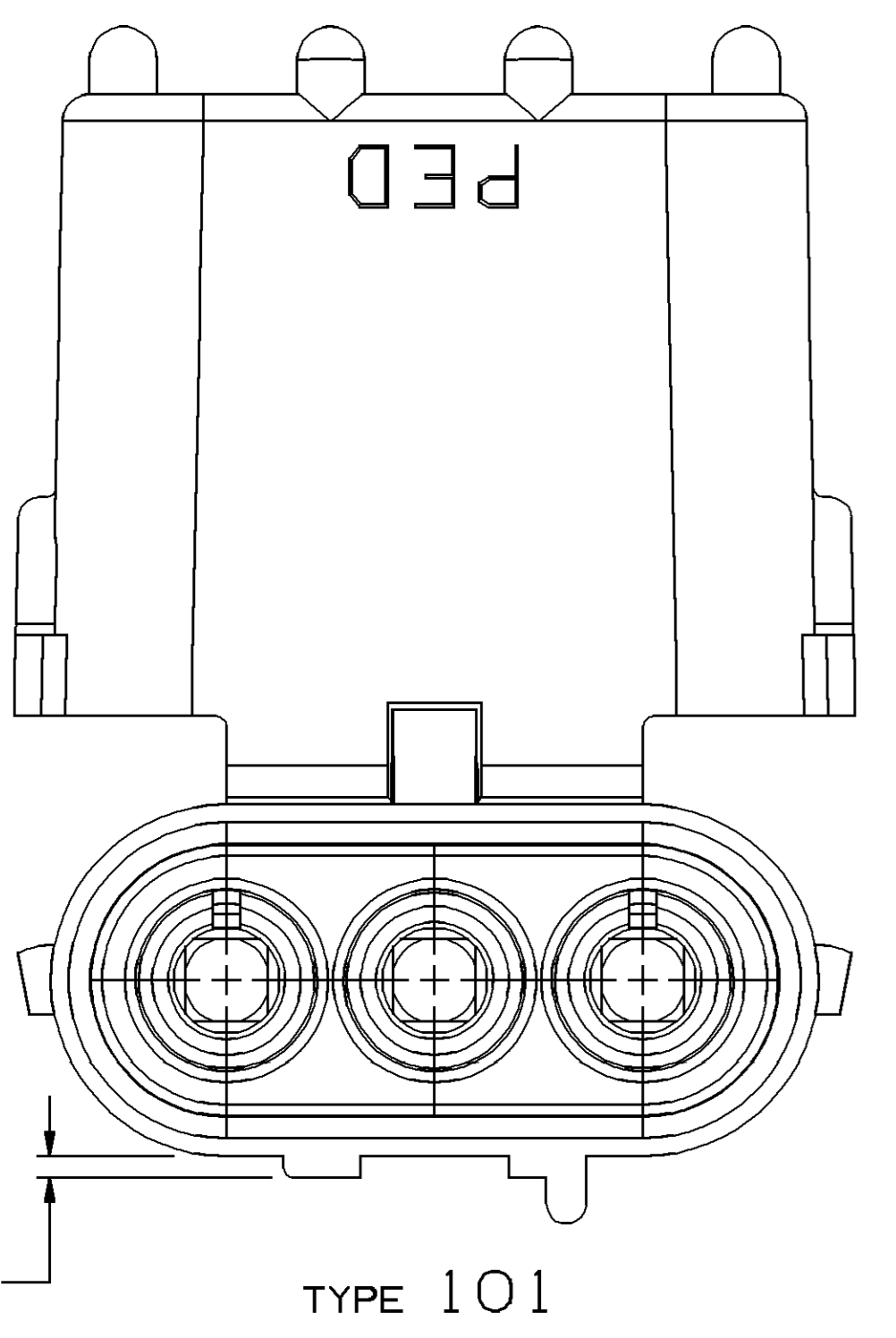

TYPE 101

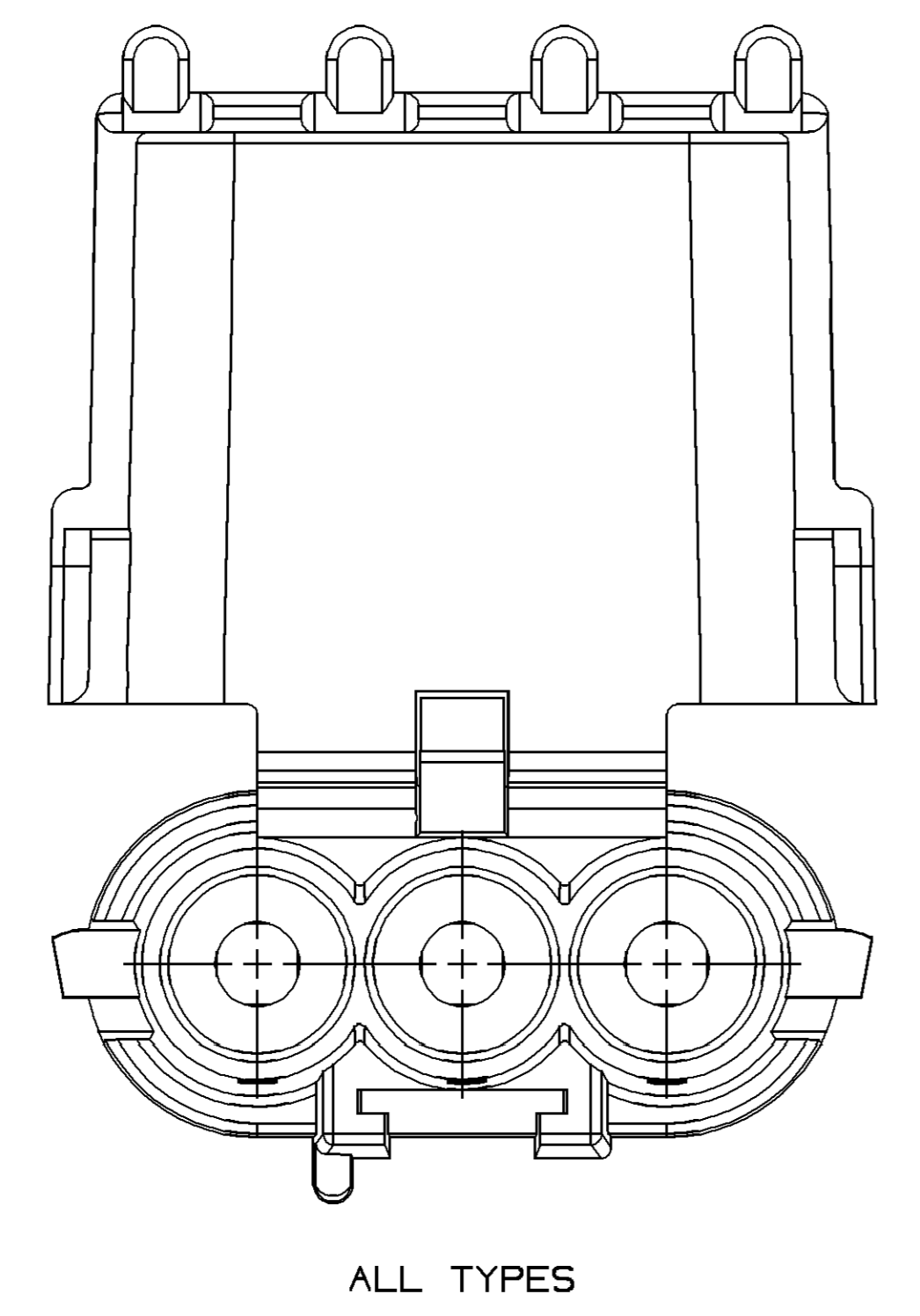

ALL TYPES

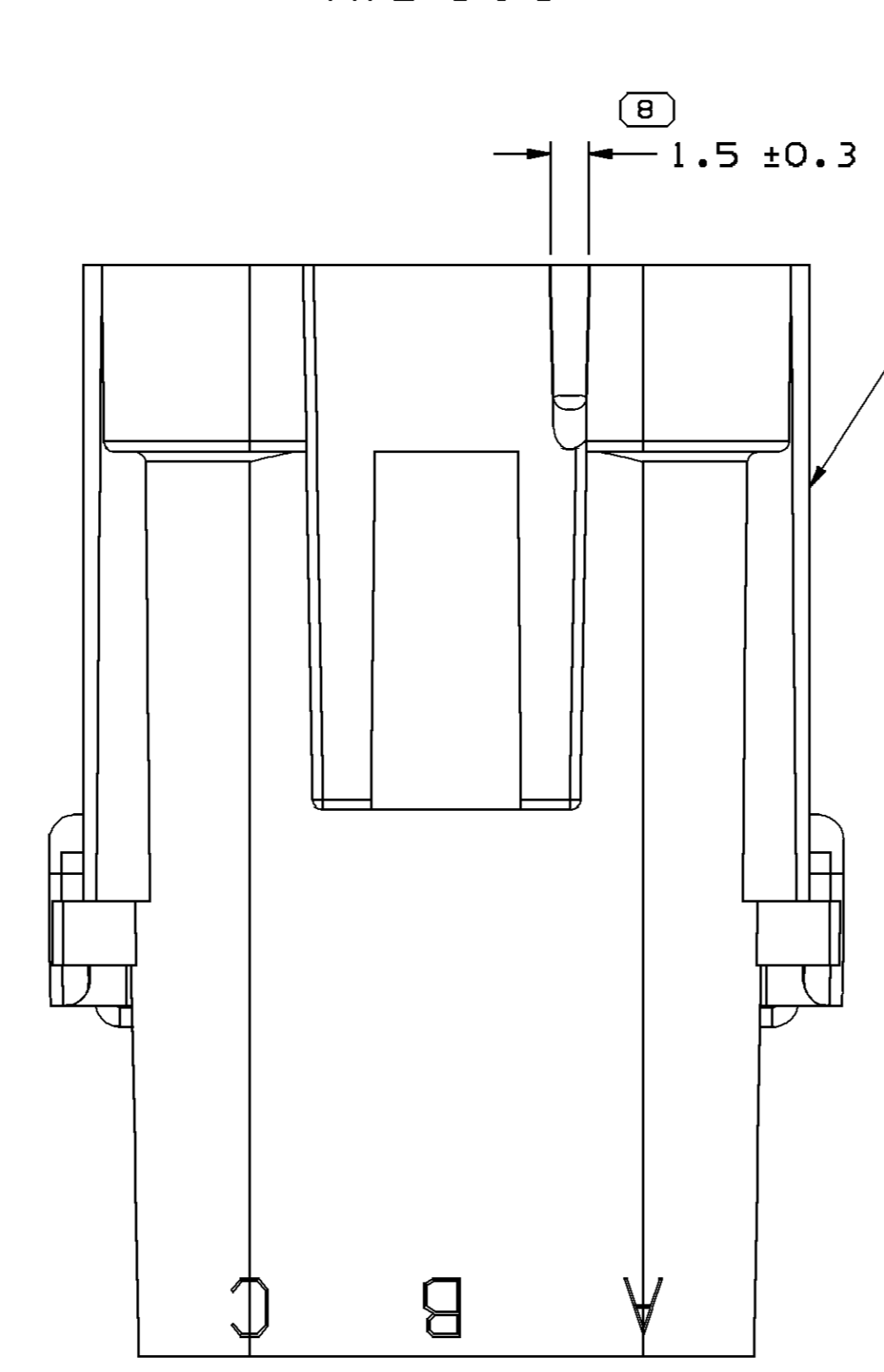

PULL OUT RIBS PERMITTED ALONG THIS AND OPPOSITE SURFACE.

NOTES

- UNLESS OTHERWISE SPECIFIED AND/OR INDICATED: DIMENSIONS ARE TO FACE OF VIEW SHOWN AND AUTOMATICALLY ROUNDED BY COMPUTER FOR INSPECTION (SEE MATH MODEL FOR PRECISE DIMENSIONS). FOR ALL OTHER DIMENSIONS NOT SHOWN BUT REQUIRED FOR TOOL BUILD, SEE MATH MODEL FOR PRECISE TOOL PATH DATA.
- SEALING CODE 3 - DESIGN WILL PASS SALT FOG AND IMMERSION TEST AFTER CONDITIONING AS SPECIFIED IN ESA-644 (WEATHER-PACK), ESA-710 (METRI-PACK), ESA-650 (UNDERHOOD-PACK), C-4006 (WORLD CONNECTOR), ETC WHEN MATED TO MATING PART OR EQUIVALENT.
- MATING COMPONENTS OR EQUIVALENT: CONNECTOR 12015793
- THIS PART ACCEPTS THE FOLLOWING COMPONENTS OR EQUIVALENT: TERMINAL 12089040, CABLE SEAL 12015323
- CAUTION: DO NOT ATTEMPT TO COPY THIS DRAWING WHEN DESIGNING A MATING PART TO A WEATHER PACK CONNECTOR. PLEASE REQUEST THE LATEST COPY OF DRAWING NUMBER 12020084 FROM THE PACKARD ELECTRIC DIVISION
- MATERIAL RECYCLING CODE >PA66< PER SAE J1344. (2.3)X(0.1) RAISED CHARACTERS AS SHOWN TO BE LOCATED ON ANY EXTERIOR SURFACE. OPTIONAL CONSTRUCTION TO BE NO MATERIAL RECYCLING CODE.
- (2.3)X(0.1) RAISED DELPHI CORPORATE BRAND TO BE LOCATED ON ANY EXTERIOR SURFACE, PREFERABLY VISIBLE AT FINAL ASSEMBLY. OPTIONAL CONSTRUCTION TO BE "PED" OR NO LOGO.
- TO VERIFY CONNECTOR PHYSICAL ATTRIBUTES OR APPEARANCE ITEMS, REFER TO VPS-226.

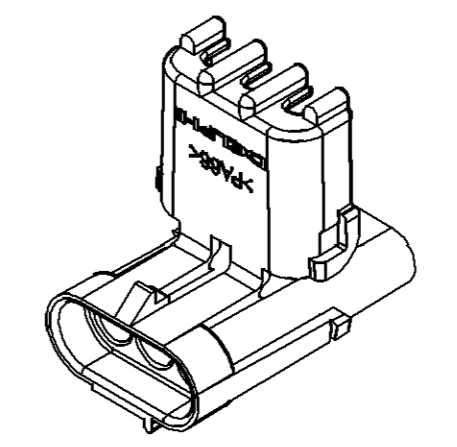

OPTIONAL CONSTRUCTION

PART NO	REV	N/P	STATUS	MATERIAL SPECIFICATION AND COLOR	TYPE	VOLUME CM <sup>3</sup>
12015460	07	AA		POLYAMIDE COMPOUND - BLU	101	7.923
12015092	07	AA		POLYAMIDE COMPOUND - RED	102	7.894
12010717	07	AA		POLYAMIDE COMPOUND - BLK	101	7.923

DIMENSIONAL RANGE (MM)		SHORT ET
FROM	> 0	> 20
TO	20	30
	30	70
	70	100
	100	150
	150	200
	200	250
	250	300
	300	400

DWG TYPE		PART DRAWING	
STYLE		DISTR CODE	D
VOLUME (C/P)	SEE CHART		

**DELPHI**  
DELPHI PACKARD ELECTRICAL/ELECTRONIC ARCHITECTURE  
WARREN, OH

DR	DATE
APV01 J.M. SOVA	16JL79
APV02 T. MUDREY	17JL79
APV03 J. YURTIN	19JL79
APV04	
APV05	

MATERIAL: SUBSTANCES OF CONCERN AND RECYCLED CONTENT PER DELPHI 10949001  
SEE CHART

DRAWING NAME: TAXI CONN M W/P SHD SLD  
DRAWING NUMBER: 12015482

SIZE: A0  
SCALE: 4:1  
FRAME NO: 1  
SHEET NO: 1 OF 1  
STG: R  
REV: 03

## X-ON Electronics

Largest Supplier of Electrical and Electronic Components

*Click to view similar products for [Automotive Connectors](#) category:*

*Click to view products by [APTIV](#) manufacturer:*

Other Similar products are found below :

[003-018-000](#) [600858](#) [60403001](#) [60993906-B](#) [60993913-B](#) [629515004020001](#) [M902-2131](#) [M902-2161](#) [M902-2344](#) [72.330.1035.1](#)  
[73.353.4028.0](#) [F118010](#) [F119300-B](#) [F132210](#) [F132210-B](#) [F166900](#) [F180100](#) [F258300](#) [F258300-B](#) [F294300-B](#) [F339100](#) [F339700](#) [F358300-](#)  
[B](#) [F374110](#) [F407400](#) [F412210](#) [F427600](#) [F444110](#) [F487000](#) [F495100-B](#) [F500900-B](#) [F509500B-B](#) [770444-1](#) [776880-1](#) [827153-1](#) [881735-1](#)  
[8N1515-32-24P](#) [9-1326727-8](#) [9-1326729-8](#) [925467-1](#) [925474-1](#) [928905-1](#) [936398-2](#) [964562-1](#) [964562-4](#) [964731-2](#) [965051-1](#) [968782-1](#)  
[GT17SA-8DS-HU](#) [GT17VS-10DP-5.2CF](#)