



5V 32K X 8 CMOS SRAM (Common I/O)

Features

- Industrial (-40° to 85°C) temperature
- Organization: 32,768 words × 8 bits
- High speed
 - 15 ns address access time
 - 6 ns output enable access time
- Low power consumption via chip deselect
- One chip select plus one Output Enable pin
- Bidirectional data inputs and outputs
- TTL-compatible
- 28-pin JEDEC standard packages
 - 300 mil SOJ
 - 8 × 13.4 mm TSOP
 - 300 mil PDIP
- ESD protection ≥ 2000 volts

Logic block diagram

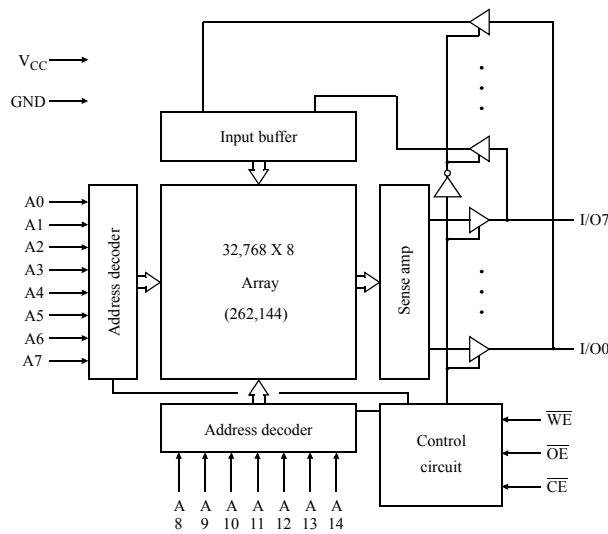

Pin arrangement

28-pin DIP, SOJ (300 mil)

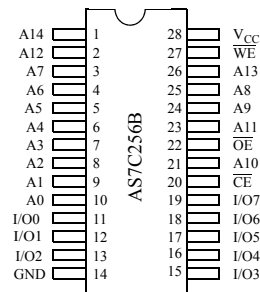

28-pin TSOP 1 (8×13.4mm)

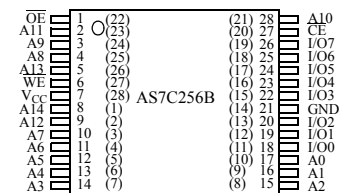

Note: This part is compatible with both pin numbering conventions used by various manufacturers.



Functional description

The AS7C256B is a 5V high-performance CMOS 262,144-bit Static Random-Access Memory (SRAM) device organized as 32,768 words \times 8 bits. It is designed for memory applications requiring fast data access at low voltage, including Pentium™, PowerPC™, and portable computing. Alliance's advanced circuit design and process techniques permit 5.0V operation without sacrificing performance or operating margins.

The device enters *standby mode* when \overline{CE} is high. Equal address access and cycle times (t_{AA} , t_{RC} , t_{WC}) of 12 ns with output enable access times (t_{OE}) of 6 ns are ideal for high-performance applications. The chip enable (\overline{CE}) input permits easy memory expansion with multiple-bank memory organizations.

A write cycle is accomplished by asserting chip enable (\overline{CE}) and write enable (\overline{WE}) LOW. Data on the input pins I/O0-I/O7 is written on the rising edge of \overline{WE} (write cycle 1) or \overline{CE} (write cycle 2). To avoid bus contention, external devices should drive I/O pins only after outputs have been disabled with output enable (\overline{OE}) or write enable (\overline{WE}).

A read cycle is accomplished by asserting chip enable (\overline{CE}) and output enable (\overline{OE}) LOW, with write enable (\overline{WE}) high. The chip drives I/O pins with the data word referenced by the input address. When chip enable or output enable is high, or write enable is low, output drivers stay in high-impedance mode.

All chip inputs and outputs are TTL-compatible. Operation is from a single 5.0 \pm 0.5V supply. The AS7C256B is packaged in high volume industry standard packages.

Absolute maximum ratings

Parameter	Symbol	Min	Max	Unit
Voltage on V_{CC} relative to GND	V_{I1}	-0.5	+7.0	V
Voltage on any pin relative to GND	V_{I2}	-0.5	$V_{CC} + 0.5$	V
Power dissipation	P_D	-	1.25	W
Storage temperature (plastic)	T_{stg}	-55	+125	°C
Ambient temperature with V_{CC} applied	T_{bias}	-55	+125	°C
DC current into outputs (low)	I_{OUT}	-	50	mA

Note:

Stresses greater than those listed under *Absolute Maximum Ratings* may cause permanent damage to the device. This is a stress rating only and functional operation of the device at these or any other conditions outside those indicated in the operational sections of this specification is not implied. Exposure to absolute maximum rating conditions for extended periods may affect reliability.

Truth table

\overline{CE}	\overline{WE}	\overline{OE}	Data	Mode
H	X	X	High Z	Standby (I_{SB} , I_{SB1})
L	H	H	High Z	Output disable (I_{CC})
L	H	L	D_{OUT}	Read (I_{CC})
L	L	X	D_{IN}	Write (I_{CC})

Notes:

H = V_{IH} , L = V_{IL} , x = Don't care.

$V_{LC} = 0.2V$, $V_{HC} = V_{CC} - 0.2V$.

Other inputs $\geq V_{HC}$ or V_{LC} .



Recommended operating conditions

Parameter	Symbol	Min	Typical	Max	Unit
Supply voltage	V_{CC}	4.5	5.0	5.5	V
Input voltage	V_{IH}	2.2	–	$V_{CC}+0.5$	V
	$V_{IL}^{(1)}$	$-0.5^{(1)}$	–	0.8	V
Ambient operating temperature (Industrial)	T_A	–40	–	85	°C

Note:

1 V_{IL} min = –1.5V for pulse width less than 10ns, once per cycle.

DC operating characteristics (over the operating range)¹

Parameter	Symbol	Test conditions	AS7C256B-17		Unit
			Min	Max	
Input leakage current	$ I_{LI} $	$V_{CC} = \text{Max}, V_{in} = \text{GND to } V_{CC}$	–	5	μA
Output leakage current	$ I_{LO} $	$V_{CC} = \text{Max}, \overline{CS} = V_{IH}, V_{OUT} = \text{GND to } V_{CC}$	–	5	μA
Operating power supply current	I_{CC}	$V_{CC} = \text{Max}, \overline{CE} \leq V_{IL}$ $f = f_{Max}, I_{OUT} = 0\text{mA}$	–	150	mA
Standby power supply current	I_{SB}	$V_{CC} = \text{Max}, \overline{CE} \geq V_{IH}$ $f = f_{Max}, I_{OUT} = 0\text{mA}$	–	40	mA
	I_{SB1}	$V_{CC} = \text{Max}, \overline{CE} \geq V_{CC}-0.2\text{V}$ $V_{IN} \leq \text{GND} + 0.2\text{V}$ or $V_{IN} \geq V_{CC}-0.2\text{V}, f = 0^{(2)}$	–	15	mA
Output voltage	V_{OL}	$I_{OL} = 8 \text{ mA}, V_{CC} = \text{Min}$	–	0.4	V
	V_{OH}	$I_{OH} = -4 \text{ mA}, V_{CC} = \text{Min}$	2.4	–	V

Notes:

All values are maximum guaranteed values.

$f_{Max} = 1/t_{RC}$, only address inputs cycling at f_{Max} , $f = 0$ means that no inputs are cycling.

Capacitance ($f = 1\text{MHz}, T_a = \text{room temperature}, V_{CC} = \text{NOMINAL}$)²

Parameter	Symbol	Signals	Test conditions	Max	Unit
Input capacitance	C_{IN}	A, \overline{CE} , \overline{WE} , \overline{OE}	$V_{in} = 3\text{dV}$	7	pF
I/O capacitance	$C_{I/O}$	I/O	$V_{out} = 3\text{dV}$	7	pF

Note:



This parameter is guaranteed by device characterization, but is not production tested.



Read cycle (over the operating range)^{3,9}

Parameter	Symbol	AS7C256B-17		Unit	Notes
		Min	Max		
Read cycle time	t_{RC}	15	-	ns	
Address access time	t_{AA}		15	ns	3
Chip enable (\overline{CE}) access time	t_{ACE}		15	ns	3
Output enable (\overline{OE}) access time	t_{OE}	-	7	ns	
Output hold from address change	t_{OH}	3	-	ns	5
\overline{CE} LOW to output in low Z	t_{CLZ}	4	-	ns	4, 5
\overline{CE} HIGH to output in high Z	t_{CHZ}	0	7	ns	4, 5
\overline{OE} LOW to output in low Z	t_{OLZ}	0	-	ns	4, 5
\overline{OE} HIGH to output in high Z	t_{OHZ}	0	6	ns	4, 5
Power up time	t_{PU}	0	-	ns	4, 5
Power down time	t_{PD}	-	15	ns	4, 5

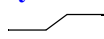
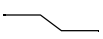
Key to switching waveforms

 Rising input
  Falling input
  Undefined output/don't care

Read waveform 1 (address controlled)^{3,6,7,9}

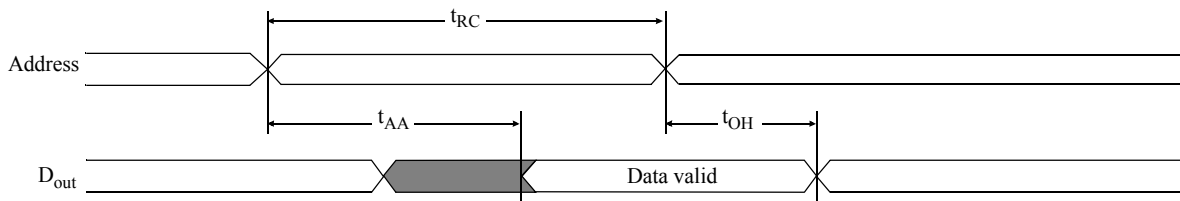

Read waveform 2 (\overline{CE} controlled)^{3,6,8,9}

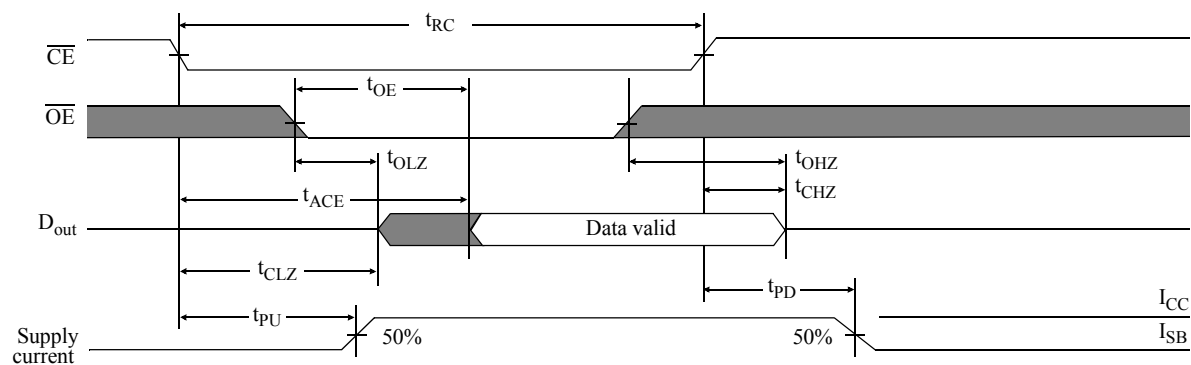



Write cycle (over the operating range)¹¹

Parameter	Symbol	AS7C256B-15		Unit	Notes
		Min	Max		
Write cycle time	t_{WC}	15	–	ns	
Chip enable to write end	t_{CW}	10	–	ns	
Address setup to write end	t_{AW}	10	–	ns	
Address setup time	t_{AS}	0	–	ns	
Write pulse width	t_{WP}	10	–	ns	
Write recovery time	t_{WR}	0	–	ns	
Address hold from end of write	t_{AH}	0	–	ns	
Data valid to write end	t_{DW}	7	–	ns	
Data hold time	t_{DH}	0	–	ns	4, 5
Write enable to output in high Z	t_{WZ}	0	6	ns	4, 5
Output active from write end	t_{OW}	4	–	ns	4, 5

Shaded areas contain advance information.

Write waveform 1 (\overline{WE} controlled)^{10,11}

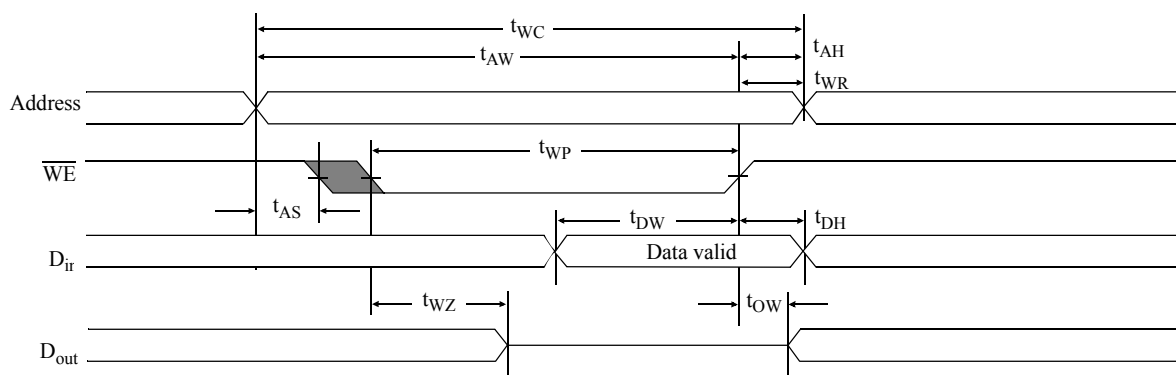

Write waveform 2 (\overline{CE} controlled)^{10,11}

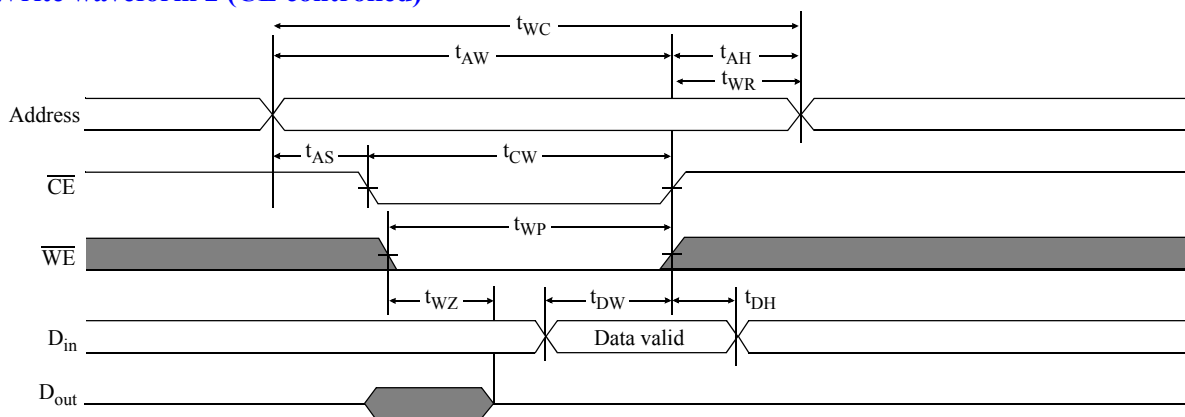



AC test conditions

- Output load: see Figure B.
- Input pulse level: GND to V_{CC} . See Figure A.
- Input rise and fall times: 3 ns. See Figure A.
- Input and output timing reference levels: 1.5V.

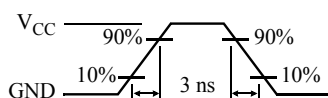

Figure A: Input pulse

Thevenin equivalent

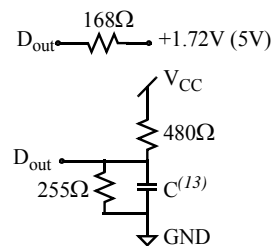

Figure B: Output load

Notes

- 1 During V_{CC} power-up, a pull-up resistor to V_{CC} on \overline{CE} is required to meet I_{SB} specification.
- 2 This parameter is sampled, but not 100% tested.
- 3 For test conditions, see *AC Test Conditions*, Figures A and B.
- 4 These parameters are specified with $C_L = 5\text{pF}$, as in Figures B. Transition is measured $\pm 200\text{mV}$ from steady-state voltage.
- 5 This parameter is guaranteed, but not tested.
- 6 \overline{WE} is High for read cycle.
- 7 \overline{CE} and \overline{OE} are Low for read cycle.
- 8 Address valid prior to or coincident with \overline{CE} transition Low.
- 9 All read cycle timings are referenced from the last valid address to the first transitioning address.
- 10 \overline{CE} or \overline{WE} must be High during address transitions. Either \overline{CE} or \overline{WE} asserting high terminates a write cycle.
- 11 All write cycle timings are referenced from the last valid address to the first transitioning address.
- 12 $\overline{CE1}$ and $\overline{CE2}$ have identical timing.
- 13 $C = 30\text{pF}$, except on High Z and Low Z parameters, where $C = 5\text{pF}$.



Package diagrams

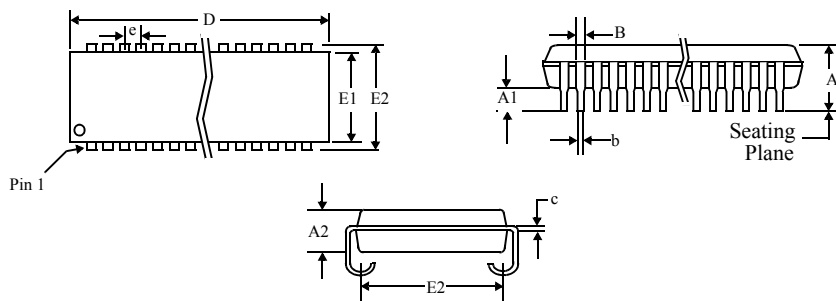

28-pin SOJ		
	Min	Max
in mils		
A	-	0.140
A1	0.025	-
A2	0.095	0.105
B	0.028 TYP	
b	0.018 TYP	
c	0.010 TYP	
D	-	0.730
E	0.245	0.285
E1	0.295	0.305
E2	0.327	0.347
e	0.050 BSC	

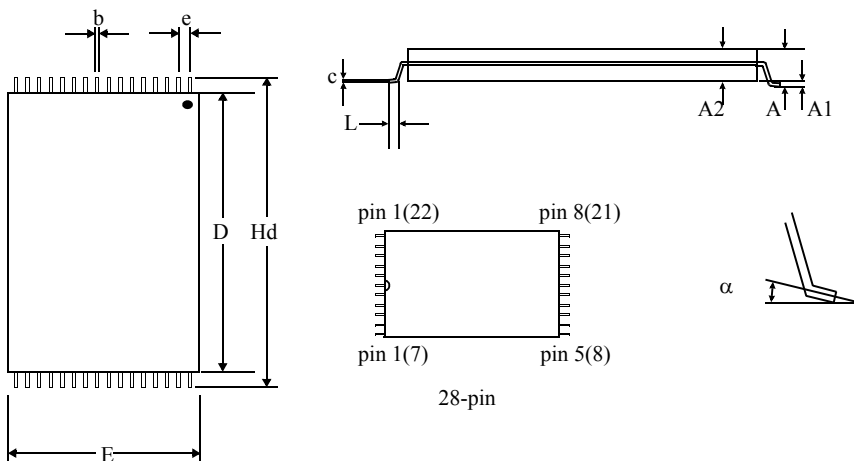

28-pin TSOP 8×13.4 mm		
	Min	Max
A	-	1.20
A1	0.10	0.20
A2	0.95	1.05
b	0.15	0.25
c	0.10	0.20
D	11.60	11.80
e	0.55 nominal	
E	8.0 nominal	
Hd	13.30	13.50
L	0.50	0.70
α	0°	5°

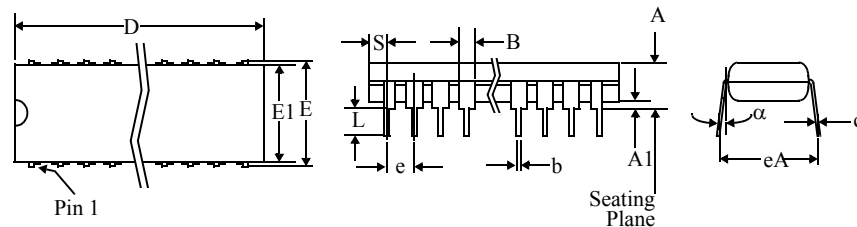

28-pin PDIP		
	Min	Max
in mils		
A	-	0.180
A1	0.010	-
B	0.040	0.065
b	0.014	0.022
c	0.008	0.014
D	-	1.400
E	0.295	0.320
E1	0.278	0.298
e	0.100 BSC	
eA	0.330	0.380
L	0.120	0.140
a	0°	15°
S	-	0.055

Note: This part is compatible with both pin numbering conventions used by various manufacturers.



Ordering information

Package	Volt/Temp	12 ns
Plastic DIP, 300 mil	5V industrial	AS7C256B-12PIN
Plastic SOJ, 300 mil	5V industrial	AS7C256B-15JIN
TSOP 8x13.4 mm	5V industrial	AS7C256B-12TIN

Part numbering system

AS7C	256B	-XX	X	I	X
SRAM prefix	Device number	Access time	Package: P=DIP 300 mil J=SOJ 300 mil T=TSOP 8x13.4 mm	Temperature range: I = -40C to 85C	N=Lead Free Part

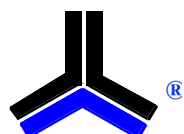

Alliance Memory, Inc.
551 Taylor Way, Suite #1
San Carlos, CA 94070 USA
Tel: 650-610-6800
Fax: 650-620-9211

www.alliancememory.com

Copyright © Alliance Memory
All Rights Reserved
Part Number: AS7C256B
Document Version: v.1.0

© Copyright 2003 Alliance Memory, Inc. All rights reserved. Our three-point logo, our name and Intelliwatt are trademarks or registered trademarks of Alliance. All other brand and product names may be the trademarks of their respective companies. Alliance reserves the right to make changes to this document and its products at any time without notice. Alliance assumes no responsibility for any errors that may appear in this document. The data contained herein represents Alliance's best data and/or estimates at the time of issuance. Alliance reserves the right to change or correct this data at any time, without notice. If the product described herein is under development, significant changes to these specifications are possible. The information in this product data sheet is intended to be general descriptive information for potential customers and users, and is not intended to operate as, or provide, any guarantee or warranty to any user or customer. Alliance does not assume any responsibility or liability arising out of the application or use of any product described herein, and disclaims any express or implied warranties related to the sale and/or use of Alliance products including liability or warranties related to fitness for a particular purpose, merchantability, or infringement of any intellectual property rights, except as expressly agreed to in Alliance's Terms and Conditions of Sale (which are available from Alliance). All sales of Alliance products are made exclusively according to Alliance's Terms and Conditions of Sale. The purchase of products from Alliance does not convey a license under any patent rights, copyrights, mask works rights, trademarks, or any other intellectual property rights of Alliance or third parties. Alliance does not authorize its products for use as critical components in life-supporting systems where a malfunction or failure may reasonably be expected to result in significant injury to the user, and the inclusion of Alliance products in such life-supporting systems implies that the manufacturer assumes all risk of such use and agrees to indemnify Alliance against all claims arising from such use.

X-ON Electronics

Largest Supplier of Electrical and Electronic Components

Click to view similar products for [SRAM](#) category:

Click to view products by [Alliance Memory](#) manufacturer:

Other Similar products are found below :

[5962-8855206XA](#) [CY6116A-35DMB](#) [CY7C128A-45DMB](#) [CY7C1461KV33-133AXI](#) [CY7C199-45LMB](#) [GS8161Z36DD-200I](#) [GS88237CB-200I](#) [R1QDA7236ABB-20IB0](#) [RMLV0408EGSB-4S2#AA0](#) [IS64WV3216BLL-15CTLA3](#) [IS66WVE4M16ECLL-70BLI](#) [PCF8570P](#) [K6T4008C1B-GB70](#) [CY7C1353S-100AXC](#) [AS6C8016-55BIN](#) [AS7C164A-15PCN](#) [515712X](#) [IS62WV51216EBLL-45BLI](#) [IS63WV1288DBLL-10HLI](#) [IS66WVE2M16ECLL-70BLI](#) [47L16-E/SN](#) [IS66WVE4M16EALL-70BLI](#) [IS62WV6416DBLL-45BLI](#) [IS61WV102416DBLL-10TLI](#) [CY7C1381KV33-100AXC](#) [CY7C1381KV33-100BZXI](#) [CY7C1373KV33-100AXC](#) [CY7C1381KVE33-133AXI](#) [CY7C4042KV13-933FCXC](#) [8602501XA](#) [5962-3829425MUA](#) [5962-8855206YA](#) [5962-8866201XA](#) [5962-8866201YA](#) [5962-8866204TA](#) [5962-8866206MA](#) [5962-8866207NA](#) [5962-8866208UA](#) [5962-8872502XA](#) [5962-8959836MZA](#) [5962-8959841MZA](#) [5962-9062007MXA](#) [5962-9161705MXA](#) [N08L63W2AB7I](#) [7130LA100PDG](#) [M38510/28902BVA](#) [5962-8971203XA](#) [5962-8971202ZA](#) [5962-8872501LA](#) [5962-8866207UA](#)