



## 512K X 16 BIT HIGH SPEED CMOS SRAM

### FEATURES

- Fast access time : 10ns
- **low power consumption:**  
Operating current:  
80mA (TYP. 10/ns)  
Standby current:  
3mA(TYP)
- Single 3.3V power supply
- All inputs and outputs TTL compatible
- Fully static operation
- Tri-state output
- Data byte control : LB# (DQ0 ~ DQ7)  
UB# (DQ8 ~ DQ15)
- Data retention voltage : 1.5V (MIN.)
- **Green package available**
- Package : 44-pin 400 mil TSOP-II  
48-ball 6mmx8mm TFBGA

### GENERAL DESCRIPTION

The AS7C38098A is a 8M-bit high speed CMOS static random access memory organized as 512K words by 16 bits. It is fabricated using very high performance, high reliability CMOS technology. Its standby current is stable within the range of operating temperature.

The AS7C38098A operates from a single power supply of 3.3V and all inputs and outputs are fully TTL compatible

### PRODUCT FAMILY

Product Family	Operating Temperature	Vcc Range	Speed	Power Dissipation	
				Standby(IsB1,TYP.)	Operating(Icc1,TYP.)
AS7C38098A	-40 ~ 85°C	2.7 ~ 3.6V	10ns	3mA	80/70mA



**512K X 16 BIT HIGH SPEED CMOS SRAM**

**FUNCTIONAL BLOCK DIAGRAM**

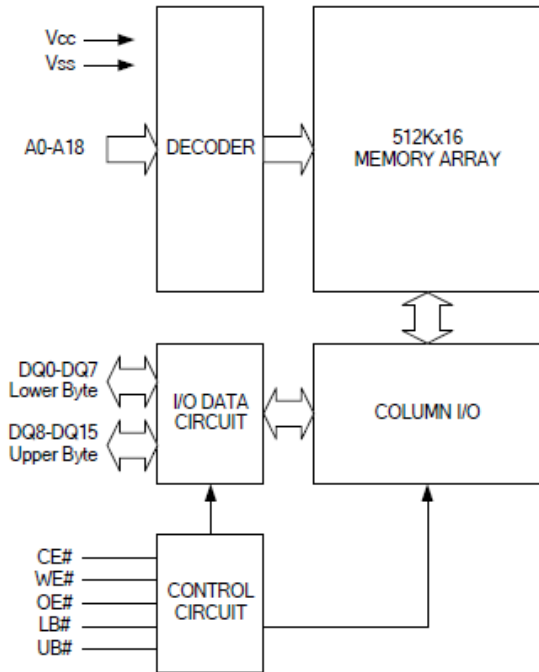

**PIN DESCRIPTION**

SYMBOL	DESCRIPTION
A0 - A18	Address Inputs
DQ0 – DQ15	Data Inputs/Outputs
CE#	Chip Enable Input
WE#	Write Enable Input
OE#	Output Enable Input
LB#	Lower Byte Control
UB#	Upper Byte Control
Vcc	Power Supply
Vss	Ground



**512K X 16 BIT HIGH SPEED CMOS SRAM**

**PIN CONFIGURATION**

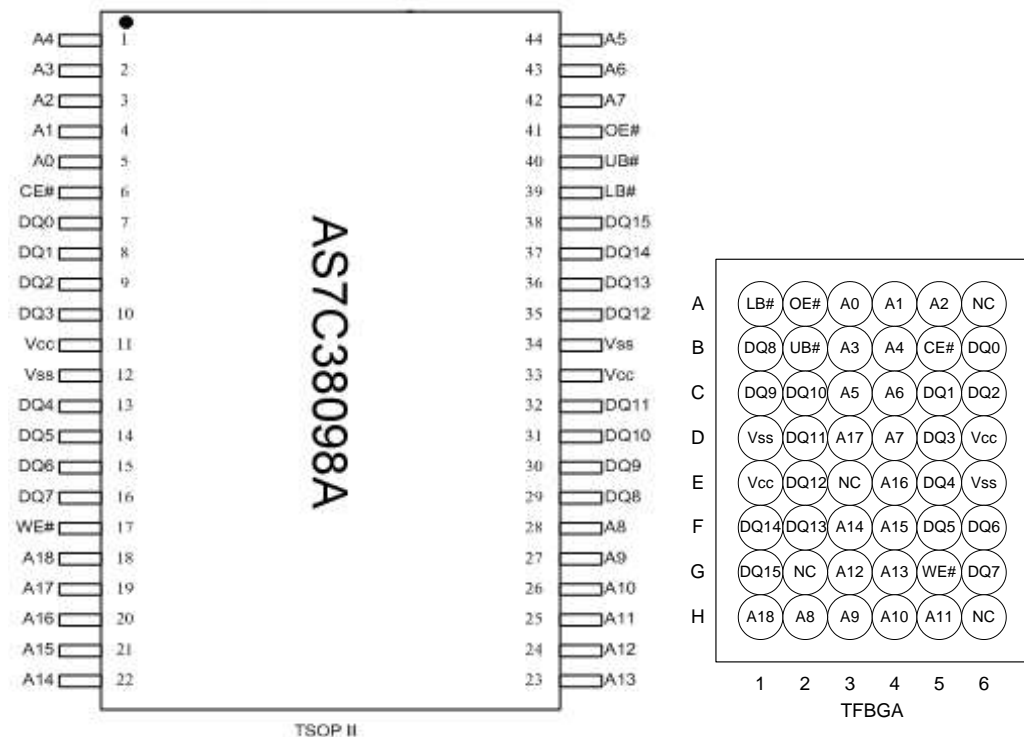

**ABSOLUTE MAXIMUM RATINGS\***

PARAMETER	SYMBOL	RATING	UNIT
Terminal Voltage with Respect to Vss	V <sub>TERM</sub>	-0.5 to 4.6	V
Operating Temperature	T <sub>A</sub>	-40 to 85	°C
Storage Temperature	T <sub>STG</sub>	-65 to 150	°C
Power Dissipation	P <sub>D</sub>	1	W
DC Output Current	I <sub>OUT</sub>	50	mA
Soldering Temperature (under 10 sec)	T <sub>SOLDER</sub>	260	°C

\*Stresses greater than those listed under "Absolute Maximum Ratings" may cause permanent damage to the device. This is a stress rating only and functional operation of the device or any other conditions above those indicated in the operational sections of this specification is not implied. Exposure to the absolute maximum rating conditions for extended period may affect device reliability.



## 512K X 16 BIT HIGH SPEED CMOS SRAM

### TRUTH TABLE

MODE	CE#	OE#	WE#	LB#	UB#	I/O OPERATION		SUPPLY CURRENT
						DQ0-DQ7	DQ8-DQ15	
Standby	H	X	X	X	X	High - Z	High - Z	I <sub>SB1</sub>
Output Disable	L	H	H	X	X	High - Z	High - Z	I <sub>CC</sub>
	L	X	X	H	H	High - Z	High - Z	
Read	L	L	H	L	H	D <sub>OUT</sub>	High - Z	I <sub>CC</sub>
	L	L	H	H	L	High - Z	D <sub>OUT</sub>	
	L	L	H	L	L	D <sub>OUT</sub>	D <sub>OUT</sub>	
Write	L	X	L	L	H	D <sub>IN</sub>	High - Z	I <sub>CC</sub>
	L	X	L	H	L	High - Z	D <sub>IN</sub>	
	L	X	L	L	L	D <sub>IN</sub>	D <sub>IN</sub>	

Note: H = V<sub>IH</sub>, L = V<sub>IL</sub>, X = Don't care.

### DC ELECTRICAL CHARACTERISTICS

PARAMETER	SYMBOL	TEST CONDITION	MIN.	TYP. <sup>4</sup>	MAX.	UNIT	
Supply Voltage	V <sub>CC</sub>		-10	2.7	3.3	3.6	V
Input High Voltage	V <sub>IH</sub> <sup>1</sup>			2.2	-	V <sub>CC</sub> +0.3	V
Input Low Voltage	V <sub>IL</sub> <sup>2</sup>			-0.3	-	0.8	V
Input Leakage Current	I <sub>LI</sub>	V <sub>CC</sub> ≥ V <sub>IN</sub> ≥ V <sub>SS</sub>		-1	-	1	μA
Output Leakage Current	I <sub>LO</sub>	V <sub>CC</sub> ≥ V <sub>OUT</sub> ≥ V <sub>SS</sub> , Output Disabled		-1	-	1	μA
Output High Voltage	V <sub>OH</sub>	I <sub>OH</sub> = -8mA		2.4	-	-	V
Output Low Voltage	V <sub>OL</sub>	I <sub>OL</sub> = 4mA		-	-	0.4	V
Average Operating Power supply Current	I <sub>CC</sub>	CE# = V <sub>IL</sub> , I <sub>I/O</sub> = 0mA ;f=max	-10	-	100	130	mA
	I <sub>CC1</sub>	CE# ≥ V <sub>CC</sub> - 0.2V, Other pin is at 0.2V or V <sub>CC</sub> -0.2V, I <sub>I/O</sub> = 0mA;f=max	-10		80	110	mA
Standby Power Supply Current	I <sub>SB</sub>	CE# ≥ V <sub>IH</sub> Other pin is at V <sub>IL</sub> or V <sub>IH</sub>				40	mA
Standby Power Supply Current	I <sub>SB1</sub>	CE# ≥ V <sub>CC</sub> - 0.2V; Other pin is at 0.2V or V <sub>CC</sub> -0.2V			3	25	mA

Notes:

- V<sub>IH</sub>(max) = V<sub>CC</sub> + 3.0V for pulse width less than 10ns.
- V<sub>IL</sub>(min) = V<sub>SS</sub> - 3.0V for pulse width less than 10ns.
- Over/Undershoot specifications are characterized, not 100% tested.
- Typical values are included for reference only and are not guaranteed or tested.

Typical values are measured at V<sub>CC</sub> = V<sub>CC</sub>(TYP.) and T<sub>A</sub> = 25°C



## 512K X 16 BIT HIGH SPEED CMOS SRAM

### CAPACITANCE ( $T_A = 25^\circ\text{C}$ , $f = 1.0\text{MHz}$ )

PARAMETER	SYMBOL	MIN.	MAX	UNIT
Input Capacitance	$C_{IN}$	-	8	pF
Input/Output Capacitance	$C_{I/O}$	-	10	pF

Note : These parameters are guaranteed by device characterization, but not production tested.

### AC TEST CONDITIONS

speed	10ns
Input Pulse Levels	0.2V to $V_{CC}-0.2\text{V}$
Input Rise and Fall Times	3ns
Input and Output Timing Reference Levels	1.5V
Output Load	$C_L = 30\text{pF} + 1\text{TTL}$ , $I_{OH}/I_{OL} = -4\text{mA}/8\text{mA}$

### AC ELECTRICAL CHARACTERISTICS

#### (1) READ CYCLE

PARAMETER	SYM.	AS7C38098A-10		UNIT
		MIN.	MAX.	
Read Cycle Time	$t_{RC}$	10	-	ns
Address Access Time	$t_{AA}$	-	10	ns
Chip Enable Access Time	$t_{ACE}$	-	10	ns
Output Enable Access Time	$t_{OE}$	-	4.5	ns
Chip Enable to Output in Low-Z	$t_{CLZ}^*$	2	-	ns
Output Enable to Output in Low-Z	$t_{OLZ}^*$	0	-	ns
Chip Disable to Output in High-Z	$t_{CHZ}^*$	-	4	ns
Output Disable to Output in High-Z	$t_{OHZ}^*$	-	4	ns
Output Hold from Address Change	$t_{OH}$	2	-	ns
LB#, UB# Access Time	$t_{BA}$	-	4.5	ns
LB#, UB# to High-Z Output	$t_{BHZ}^*$	-	4	ns
LB#, UB# to Low-Z Output	$t_{BLZ}^*$	0	-	ns

#### (2) WRITE CYCLE

PARAMETER	SYM.	AS7C38098A-10		UNIT
		MIN.	MAX.	
Write Cycle Time	$t_{WC}$	10	-	ns
Address Valid to End of Write	$t_{AW}$	8	-	ns
Chip Enable to End of Write	$t_{CW}$	8	-	ns
Address Set-up Time	$t_{AS}$	0	-	ns
Write Pulse Width	$t_{WP}$	8	-	ns
Write Recovery Time	$t_{WR}$	0	-	ns
Data to Write Time Overlap	$t_{DW}$	6	-	ns
Data Hold from End of Write Time	$t_{DH}$	0	-	ns
Output Active from End of Write	$t_{OW}^*$	2	-	ns
Write to Output in High-Z	$t_{WHZ}^*$	-	4	ns
LB#, UB# Valid to End of Write	$t_{BW}$	8	-	ns

\*These parameters are guaranteed by device characterization, but not production tested.



**512K X 16 BIT HIGH SPEED CMOS SRAM**

**TIMING WAVEFORMS**

**READ CYCLE 1 (Address Controlled) (1,2)**

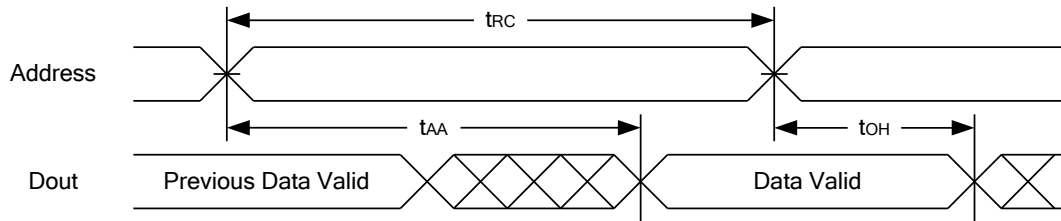

**READ CYCLE 2 (CE# and OE# Controlled) (1,3,4,5)**

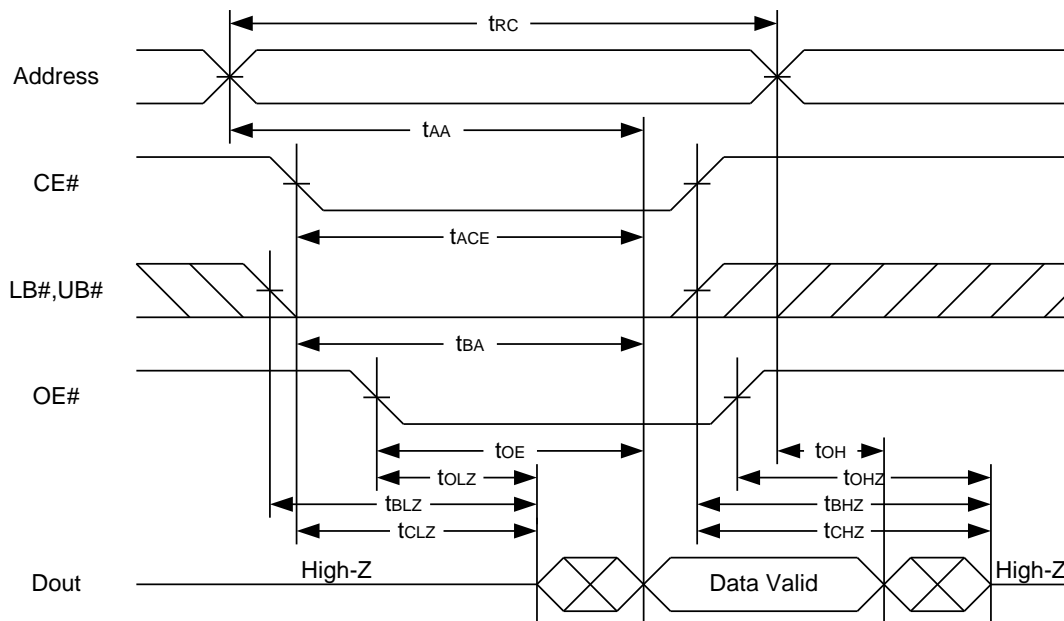

Notes :

1. WE# is high for read cycle.
2. Device is continuously selected OE# = low, CE# = low, LB# or UB# = low.
3. Address must be valid prior to or coincident with CE# = low, LB# or UB# = low transition; otherwise  $t_{AA}$  is the limiting parameter.
4.  $t_{CLZ}$ ,  $t_{BLZ}$ ,  $t_{OLZ}$ ,  $t_{CHZ}$ ,  $t_{BHZ}$  and  $t_{OHZ}$  are specified with  $C_L = 5pF$ . Transition is measured  $\pm 500mV$  from steady state.
5. At any given temperature and voltage condition,  $t_{CHZ}$  is less than  $t_{CLZ}$ ,  $t_{BHZ}$  is less than  $t_{BLZ}$ ,  $t_{OHZ}$  is less than  $t_{OLZ}$ .



**512K X 16 BIT HIGH SPEED CMOS SRAM**

**WRITE CYCLE 1 (WE# Controlled) (1,2,3,5,6)**

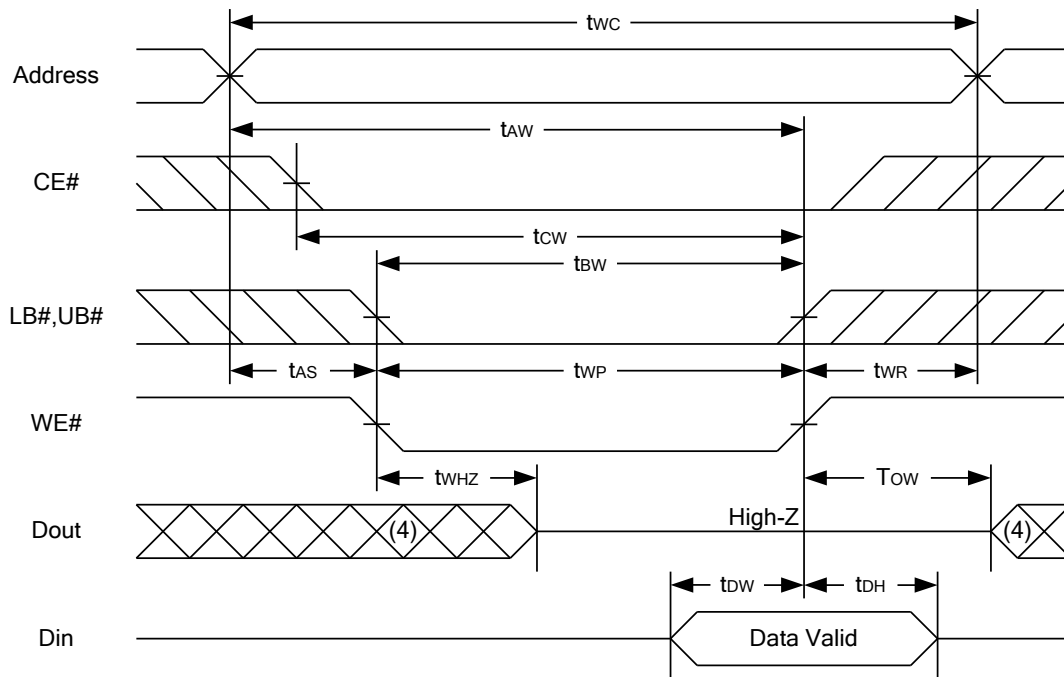

**WRITE CYCLE 2 (CE# Controlled) (1,2,5,6)**

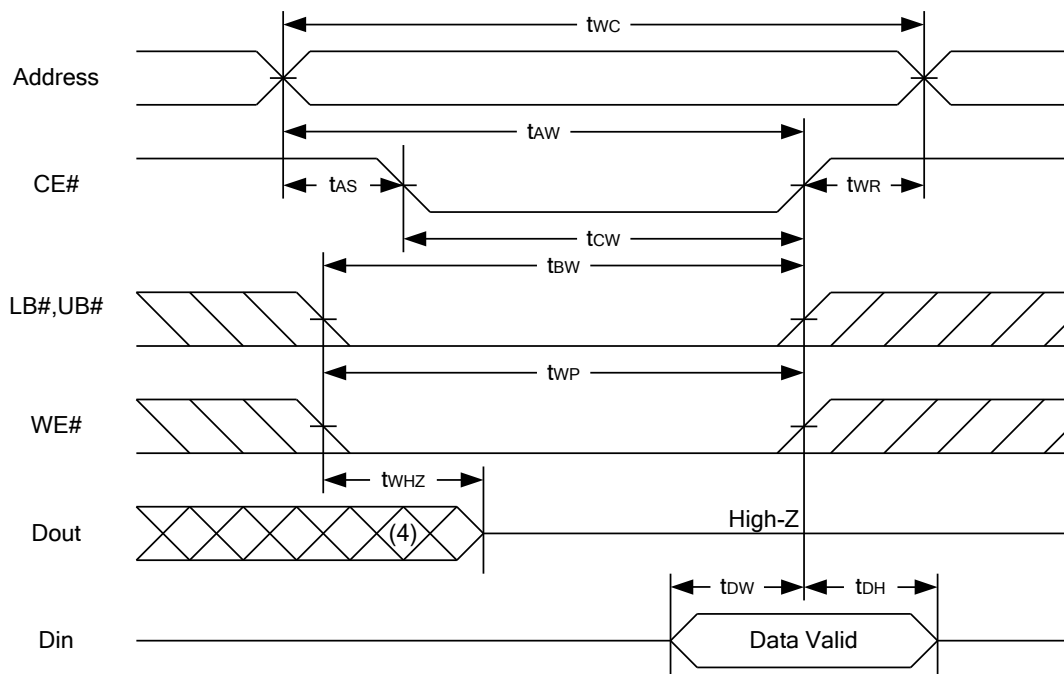



**512K X 16 BIT HIGH SPEED CMOS SRAM**

**WRITE CYCLE 3 (LB#,UB# Controlled) (1,2,5,6)**

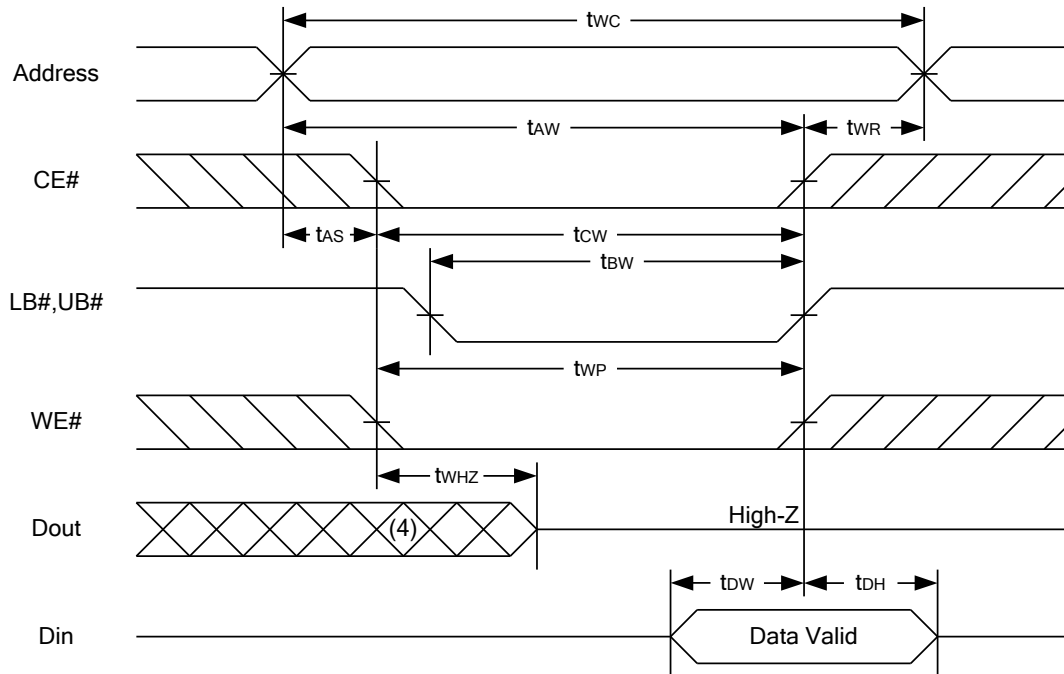

Notes :

1. WE#, CE#, LB#, UB# must be high during all address transitions.
2. A write occurs during the overlap of a low CE#, low WE#, LB# or UB# = low.
3. During a WE# controlled write cycle with OE# low, tWP must be greater than tWHZ + tDW to allow the drivers to turn off and data to be placed on the bus.
4. During this period, I/O pins are in the output state, and input signals must not be applied.
5. If the CE#, LB#, UB# low transition occurs simultaneously with or after WE# low transition, the outputs remain in a high impedance state.
6. tOW and tWHZ are specified with CL = 5pF. Transition is measured ±500mV from steady state.





**512K X 16 BIT HIGH SPEED CMOS SRAM**

**DATA RETENTION CHARACTERISTICS**

PARAMETER	SYMBOL	TEST CONDITION	MIN.	TYP.	MAX.	UNIT
VCC for Data Retention	$V_{DR}$	$CE\# \geq V_{CC} - 0.2V$	1.5	-	3.6	V
Data Retention Current	$I_{DR}$	$V_{CC} = 1.5V$ $CE\# \geq V_{CC} - 0.2V$ ; Other pin is at 0.2V or $V_{CC} - 0.2V$	-	3	25	mA
Chip Disable to Data Retention Time	$t_{CDR}$	See Data Retention Waveforms (below)	0	-	-	ns
Recovery Time	$t_R$		$t_{RC}^*$	-	-	ns

$t_{RC}^*$  = Read Cycle Time

**DATA RETENTION WAVEFORM**

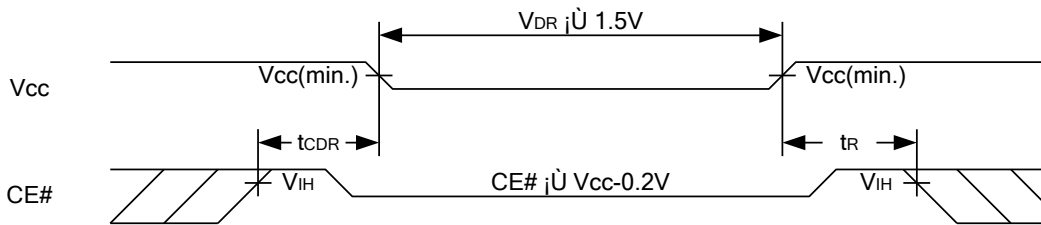



**512K X 16 BIT HIGH SPEED CMOS SRAM**

**PACKAGE OUTLINE DIMENSION**

44-pin 400mil TSOP-II Package Outline Dimension

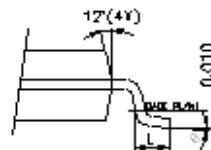
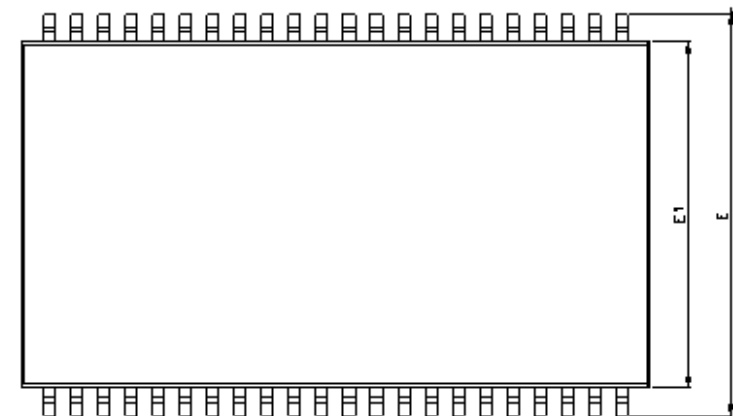

DETAIL B

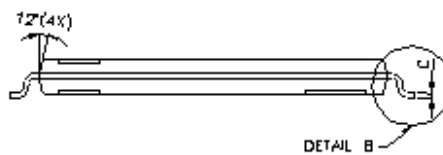
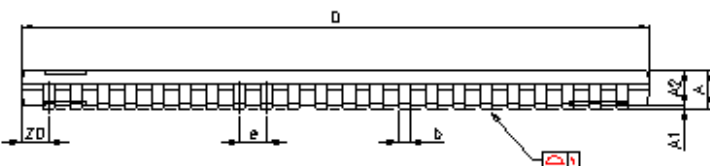

DETAIL B

SYMBOLS	DIMENSIONS IN MILLIMETERS			DIMENSIONS IN MILS		
	MIN.	NOM.	MAX.	MIN.	NOM.	MAX.
A	-	-	1.20	-	-	47.2
A1	0.05	0.10	0.15	2.0	3.9	5.9
A2	0.95	1.00	1.05	37.4	39.4	41.3
b	0.30	-	0.45	11.8	-	17.7
c	0.12	-	0.21	4.7	-	8.3
D	18.212	18.415	18.618	717	725	733
E	11.506	11.760	12.014	453	463	473
E1	9.957	10.160	10.363	392	400	408
e	-	0.800	-	-	31.5	-
L	0.40	0.50	0.60	15.7	19.7	23.6
ZD	-	0.805	-	-	31.7	-
y	-	-	0.076	-	-	3
θ	0°	3°	6°	0°	3°	6°



**512K X 16 BIT HIGH SPEED CMOS SRAM**

**48-ball 6mm x 8mm TFBGA Package Outline Dimension**

TOP VIEW

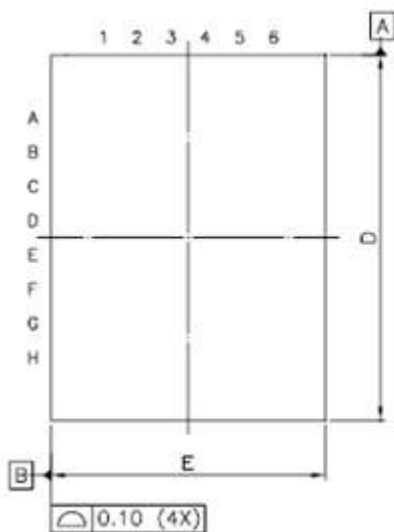

BOTTOM VIEW

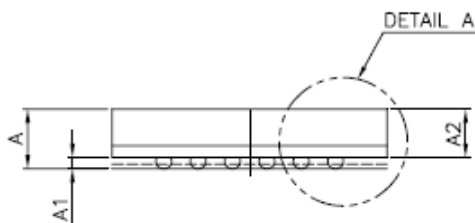
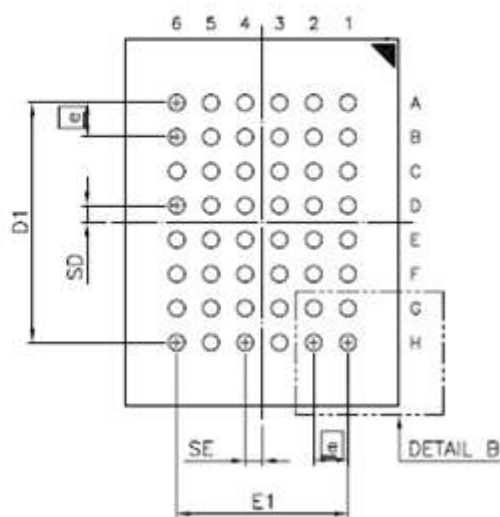

SIDE VIEW

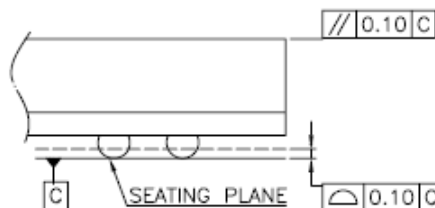

DETAIL A

SYM.	DIMENSION (mm)			DIMENSION (inch)		
	MIN.	NOM.	MAX.	MIN.	NOM.	MAX.
A	—	—	1.40	—	—	0.055
A1	0.20	0.25	0.30	0.008	0.010	0.012
A2	—	—	1.05	—	—	0.041
b	0.30	0.35	0.40	0.012	0.014	0.016
D	7.95	8.00	8.05	0.313	0.315	0.317
D1	5.25 BSC			0.207 BSC		
E	5.95	6.00	6.05	0.234	0.236	0.238
E1	3.75 BSC			0.148 BSC		
SE	0.375 TYP			0.015 TYP		
SD	0.375 TYP			0.015 TYP		
Ⓢ	0.75 BSC			0.030 BSC		

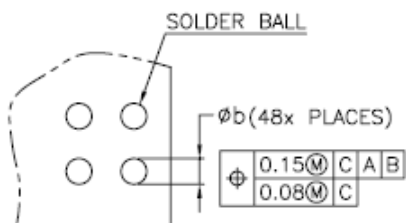

DETAIL B

NOTE:

1. CONTROLLING DIMENSION : MILLIMETER.
2. REFERENCE DOCUMENT : JEDEC MO-207.



**512K X 16 BIT HIGH SPEED CMOS SRAM**

**ORDERING INFORMATION**

**AS7C38098A - 10 x I N**

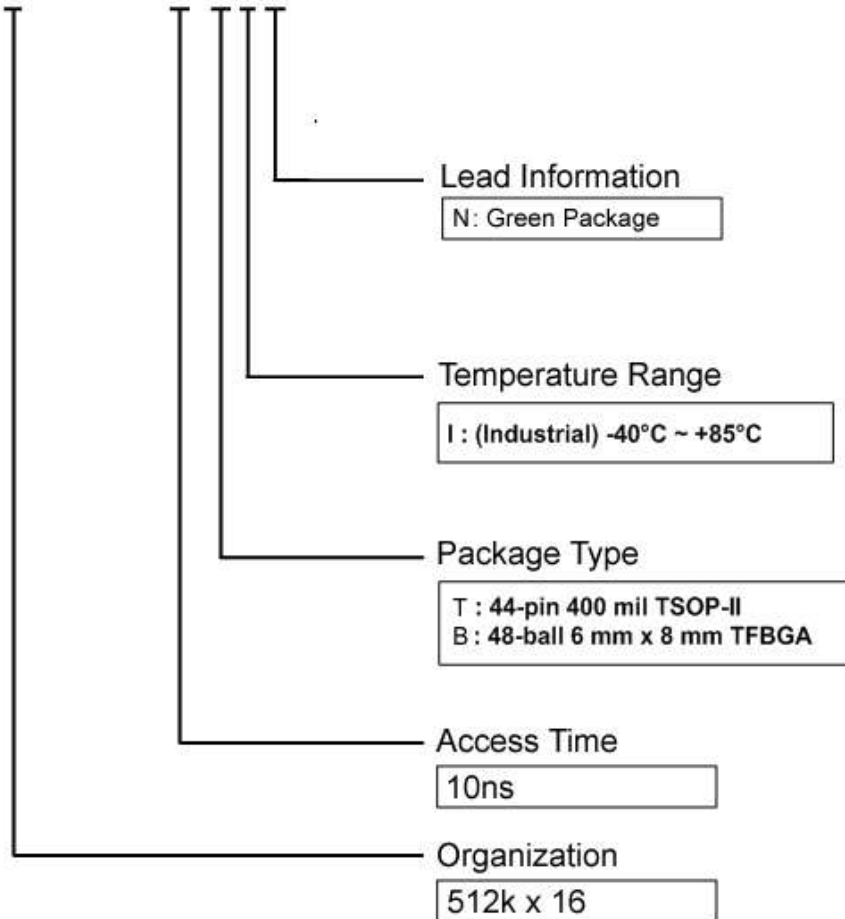

BGA : 48-ball 6 mm x 8 mm TFBGA	Industrial -40°C ~ +85°C	AS7C38098A-10BIN
TSOP II : 44-pin 400 mil TSOP II	Industrial -40°C ~ +85°C	AS7C38098A-10TIN

## X-ON Electronics

Largest Supplier of Electrical and Electronic Components

*Click to view similar products for [SRAM](#) category:*

*Click to view products by [Alliance Memory](#) manufacturer:*

Other Similar products are found below :

[5962-8855206XA](#) [CY6116A-35DMB](#) [CY7C128A-45DMB](#) [CY7C1461KV33-133AXI](#) [CY7C199-45LMB](#) [GS8161Z36DD-200I](#) [GS88237CB-200I](#) [R1QDA7236ABB-20IB0](#) [RMLV0408EGSB-4S2#AA0](#) [IS64WV3216BLL-15CTLA3](#) [IS66WVE4M16ECLL-70BLI](#) [PCF8570P](#) [K6T4008C1B-GB70](#) [CY7C1353S-100AXC](#) [AS6C8016-55BIN](#) [AS7C164A-15PCN](#) [515712X](#) [IS62WV51216EBLL-45BLI](#) [IS63WV1288DBLL-10HLI](#) [IS66WVE2M16ECLL-70BLI](#) [47L16-E/SN](#) [IS66WVE4M16EALL-70BLI](#) [IS62WV6416DBLL-45BLI](#) [IS61WV102416DBLL-10TLI](#) [CY7C1381KV33-100AXC](#) [CY7C1381KV33-100BZXI](#) [CY7C1373KV33-100AXC](#) [CY7C1381KVE33-133AXI](#) [CY7C4042KV13-933FCXC](#) [8602501XA](#) [5962-3829425MUA](#) [5962-8855206YA](#) [5962-8866201XA](#) [5962-8866201YA](#) [5962-8866204TA](#) [5962-8866206MA](#) [5962-8866207NA](#) [5962-8866208UA](#) [5962-8872502XA](#) [5962-8959836MZA](#) [5962-8959841MZA](#) [5962-9062007MXA](#) [5962-9161705MXA](#) [N08L63W2AB7I](#) [7130LA100PDG](#) [M38510/28902BVA](#) [5962-8971203XA](#) [5962-8971202ZA](#) [5962-8872501LA](#) [5962-8866207UA](#)