

Color Mark Sensor

Feature

- Outstanding color matching accuracy
 - RGB light emitting diodes and 12-bit resolution
 - 2 detection modes (color only / color + intensity)
 - 3-step sensitivity adjustment for each mode (fine, normal, rough)
- External light interference reduction minimizes errors and allows stable detection
- Check reference color with teaching indicator
- Operation indicator (red LED), stability indicator (green LED), timer indicator (orange LED)
- Configure operation functions with external input from wiring
- W1.24 × L6.7 mm spot size for detection of tiny targets and color marks
- IP67 protection structure (IEC standard)

⚠ Please read "Caution for your safety" in operation manual before using.



Overview

General photoelectric sensor detects present or absent of target by light. Color mark sensor detects colors of surfaces by RGB (red, green, and blue) light source.

Saving the desired color at the inner memory, color mark sensor emits RGB LED light source to the target sequentially. Color mark sensor calculates ratio of the three colors, RGB, for the optimized sensing via the inner light collection lens. Using off-axis optical system for minimized optical loss, and cylindrical lens, BC Series compares setting color and sensing color with full-color determination.

Applications

Packaging, stickers industry: Label status, Mark color check, etc.
Electronic components, semiconductor industry: Defective unit check, Connector color check, etc.

Specifications

Model	BC15-LDT-C	BC15-LDT-C-P
Sensing method	Convergent reflective type	
Sensing distance	15mm ±2mm	
Sensing target	Opaque, translucent	
Hysteresis	Max. 20% of sensing distance (may vary by sensing mode or sensitivity)	
Spot size	1.24×6.7mm (rectangular)	
Response time	500μs	
Power supply	12-24VDC ±10% (ripple P-P: max. 10%)	
Current consumption	Max. 30mA	
Light source	Full Color LED (red, green, blue)	
Sensing mode	C (color only) mode, C+I (color + intensity) mode	
Output mode	Color match output, color mismatch output	
Output timer	40ms OFF delay timer function	
Control output	NPN or PNP open collector output • Load voltage: max. 30V • Load current: max. 100mA • Residual voltage - NPN: max. 1V , PNP: max. 2.5V	
Protection circuit	Reverse polarity protection, output short-circuit protection	
Indicator	Operation indicator: red LED, Stability indicator: green LED, Teaching indicator: full Color LED	
Connection method	Connector type	
External input	External SET cable input	
Insulation resistance	Over 20MΩ (at 500VDC megger)	
Noise immunity	±240V of square wave noise (pulse width: 1μs) from the noise simulator	
Dielectric strength	1,000VAC at 50/60Hz for 1min	
Vibration	1.5mm amplitude at 10 to 55Hz frequency in each X, Y, Z direction for 2 hours	
Shock	500m/s ² (approx. 50G) in each X, Y, Z direction for 3 times	
Environment	Ambient illumination	Incandescent lamp: Max. 3,000lx (receiver illumination)
	Ambient temp.	-10 to 55°C, storage: -25 to 75°C
	Ambient humidity	35 to 85%RH, storage: 35 to 85%RH
Protection structure	IP67 (IEC standard)	
Material	Case: polycarbonate, Sensing part: acrylic, Bracket: stainless steel 304 , Bolt: carbon steel	
Accessories	Bracket, Fixing bolts: 2 , Adjustment screwdriver: 1	
Approval	CE	
Weight ^{※1}	Approx. 80g (approx. 14g)	

※1: The weight includes packaging. The weight in parenthesis is for unit only.

※ The temperature and humidity of environment resistance is rated at non-freezing or condensation.

NEW

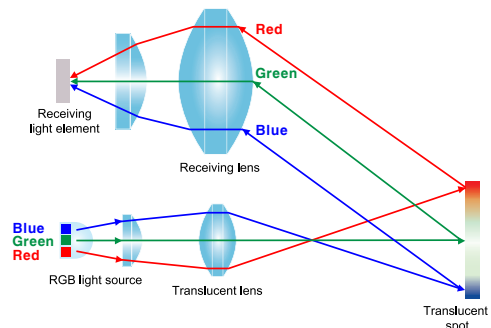

- (A) Photoelectric Sensors
- (B) Fiber Optic Sensors
- (C) Door/Area Sensors
- (D) Proximity Sensors
- (E) Pressure Sensors
- (F) Rotary Encoders
- (G) Connectors/ Connector Cables/ Sensor Distribution Boxes/Sockets
- (H) Temperature Controllers
- (I) SSRs / Power Controllers
- (J) Counters
- (K) Timers
- (L) Panel Meters
- (M) Tacho / Speed / Pulse Meters
- (N) Display Units
- (O) Sensor Controllers
- (P) Switching Mode Power Supplies
- (Q) Stepper Motors & Drivers & Controllers
- (R) Graphic/ Logic Panels
- (S) Field Network Devices
- (T) Software

BC Series

Control Output Diagram

• NPN open collector output

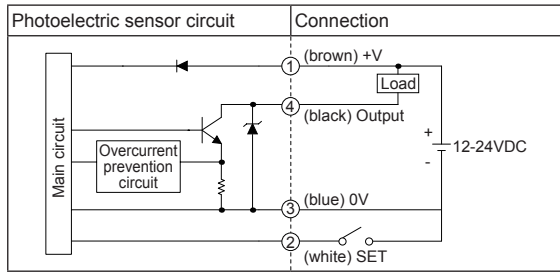

• PNP open collector output

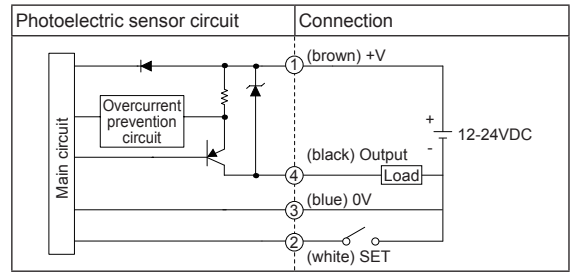

Connections For Connector Part

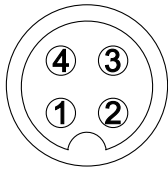

M12 Connector Pin

Pin number	Cable color	Name
1	Brown	+V
2	White	SET
3	Blue	GND (0V)
4	Black	OUT

• Connector cable (sold separately)

※Connector cable model

: CIDH4-□

(connector length □: 2, 3, 5, 7m)

※Please refer to the G-6 for connector cable.

Operation Mode

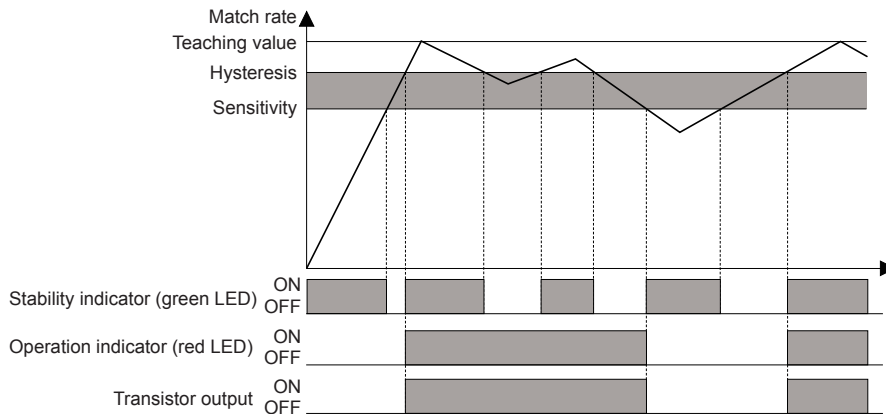

※The waveforms of "Operation indicator" and "Transistor output" are for color match mode operation. They are opposite operation for color mismatch mode operation.

Unit Description

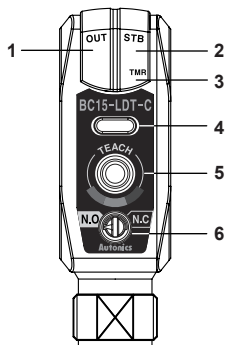

1. Operation indicator (OUT): ON (red) indicates operation.
2. Stability indicator (STB): ON (green) indicates stable status.
3. Timer indicator (TMR): ON (orange) when timer is set.
4. Teaching indicator:
Displays the reference color after successfully "teaching" the color.
※The teaching color and the color displayed on the teaching indicator may differ depending on environment conditions (ambient light, reflection angle, material, etc.) .
5. SET key: Used for function settings.
6. Color match/mismatch switch
- N.O.: Output ON when target color matches reference color.
- N.C.: Output ON when target color does not match reference color.

■ Dimensions

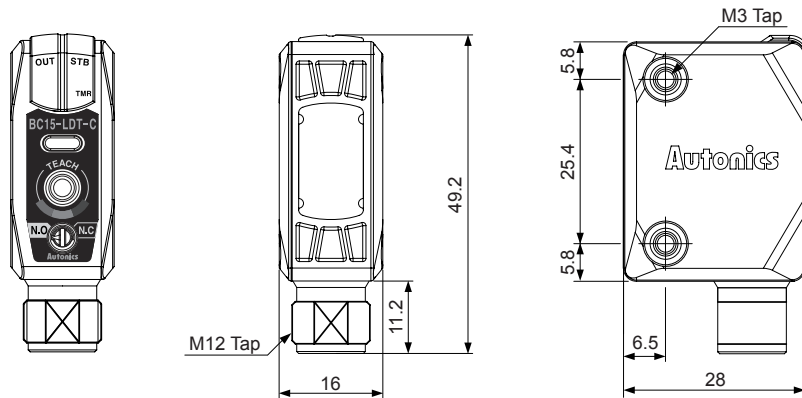

● Mounting Bracket

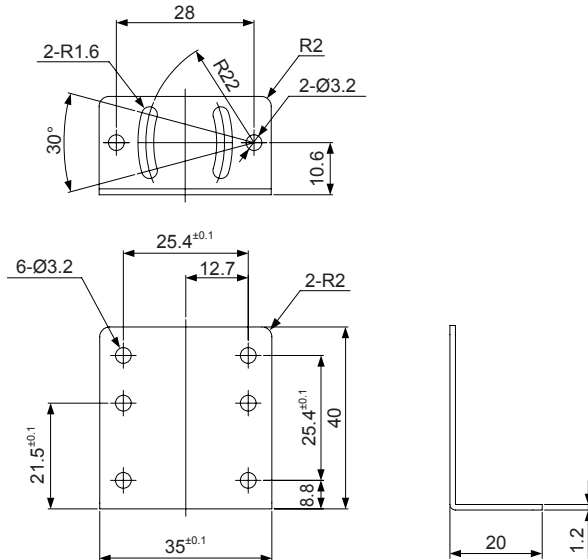

■ Installation and Sensitivity Adjustment

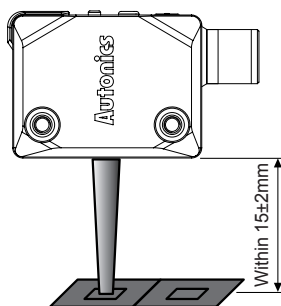

① Installation

: Place the color mark sensor and the target object facing each other then affix the unit. The installation distance should be within ± 2 mm of 15mm .

② Press the SET key to enter teaching standby status. Place the desired color at the sensing position (spot) and hold the SET key for 3 seconds to set the reference color. When it is complete, the teaching indicator will display the set color

③ Hold the SET key for 3 seconds change sensing mode and sensitivity settings.

④ Hold the SET key for 5 seconds to set the timer. The timer is a 40ms OFF delay timer.

※ In case of teaching error, the output indicator and teaching indicator will flash depending on the intensity of received light.

※ When detecting metal or glossy objects tilt install the sensor at about 10 to 20 degree angle.

(A) Photoelectric Sensors

(B) Fiber Optic Sensors

(C) Door/Area Sensors

(D) Proximity Sensors

(E) Pressure Sensors

(F) Rotary Encoders

(G) Connectors/ Connector Cables/ Sensor Distribution Boxes/Sockets

(H) Temperature Controllers

(I) SSRs / Power Controllers

(J) Counters

(K) Timers

(L) Panel Meters

(M) Tacho / Speed / Pulse Meters

(N) Display Units

(O) Sensor Controllers

(P) Switching Mode Power Supplies

(Q) Stepper Motors & Drivers & Controllers

(R) Graphic/ Logic Panels

(S) Field Network Devices

(T) Software

■ Functions

○ Color teaching

Set the reference color with the teaching function. Press the SET key in RUN mode to enter teaching standby status. Place the desired color at the sensing position (spot) and hold the SET key for over 3 seconds.

When teaching is complete, the teaching color indicator will turn ON.

When there is an error, the operation indicator will flash (red).

○ Display teaching

The set reference color can be displayed on the teaching indicator.

With the ability to check the set reference color there is no need to re-set the teaching color every time.

It may difficult to check the similar colors when installing multiple sensors.

Teaching indicator color is available only for reference.

※The teaching color and the color displayed on the teaching indicator may differ depending on environment conditions (ambient light, reflection angle, material, etc.)

○ Sensing mode, sensitivity setting (color tolerance)

Two sensing modes; C (color only) mode discriminates by color rate and C+I (color +intensity) mode discriminates by color rate and contrast. Set the sensing sensitivity (fine, normal, rough) at each sensing mode.

○ Color match/mismatch mode

- Color match mode (N.O.) : Output ON when target color matches reference color.

Turn the color match/mismatch switch towards N.O.

- Color mismatch mode (N.C.) : Output ON when target color does not match reference color.

Turn the color match/mismatch switch towards N.C.

○ OFF delay timer

Timer (40ms OFF delay) functions helps prevent output malfunction from target objects moving too rapidly. The timer indicator turns ON (orange) when the timer function is set.

■ Operation and Settings

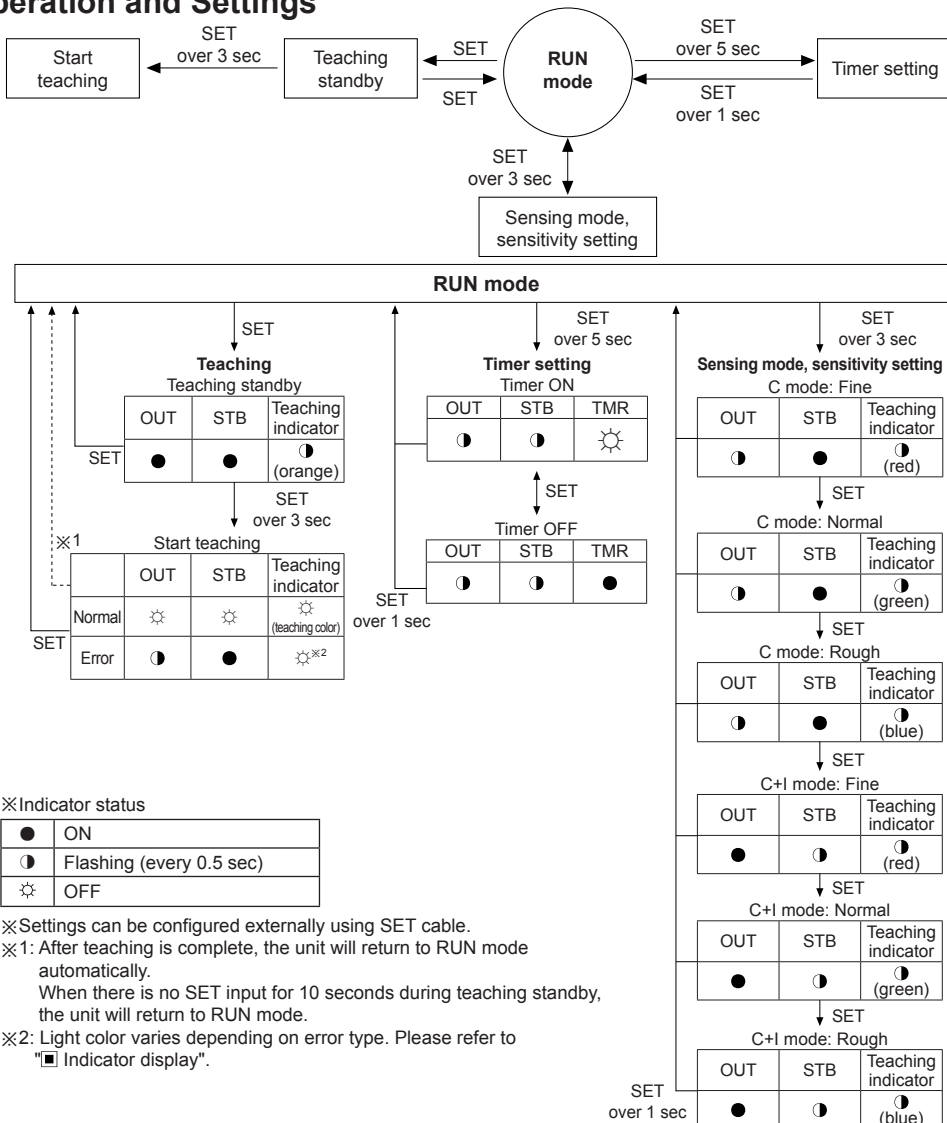

Feature Data

BC Series Standard Sensing Color

Reference color		Yellow	Red	Purple	Sky blue	Blue	Green	Black	White
		Color code	Yellow U	Red032U	Purple U	306U	Blue072U	Green U	405U
PANTONE	Uncoated	Yellow U	Red032U	Purple U	306U	Blue072U	Green U	405U	—
Color code	Coated	Yellow C	Red032C	Purple C	306C	Blue072C	Green C	405C	—

Color sensing distance by mode

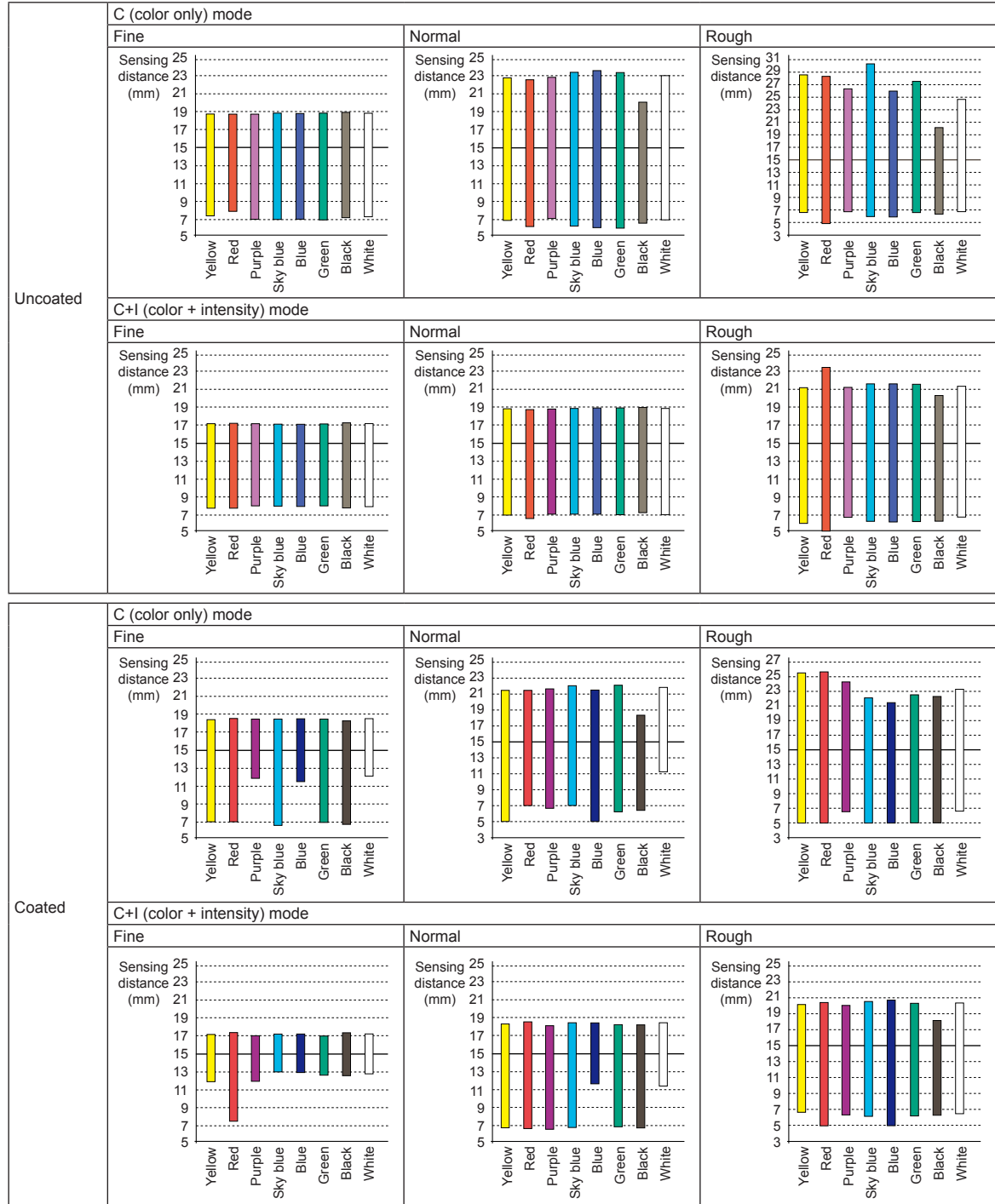

- (A) Photoelectric Sensors
- (B) Fiber Optic Sensors
- (C) Door/Area Sensors
- (D) Proximity Sensors
- (E) Pressure Sensors
- (F) Rotary Encoders
- (G) Connectors/ Connector Cables/ Sensor Distribution Boxes/Sockets
- (H) Temperature Controllers
- (I) SSRs / Power Controllers
- (J) Counters
- (K) Timers
- (L) Panel Meters
- (M) Tacho / Speed / Pulse Meters
- (N) Display Units
- (O) Sensor Controllers
- (P) Switching Mode Power Supplies
- (Q) Stepper Motors & Drivers & Controllers
- (R) Graphic/ Logic Panels
- (S) Field Network Devices
- (T) Software

BC Series

Color sensing angle by mode

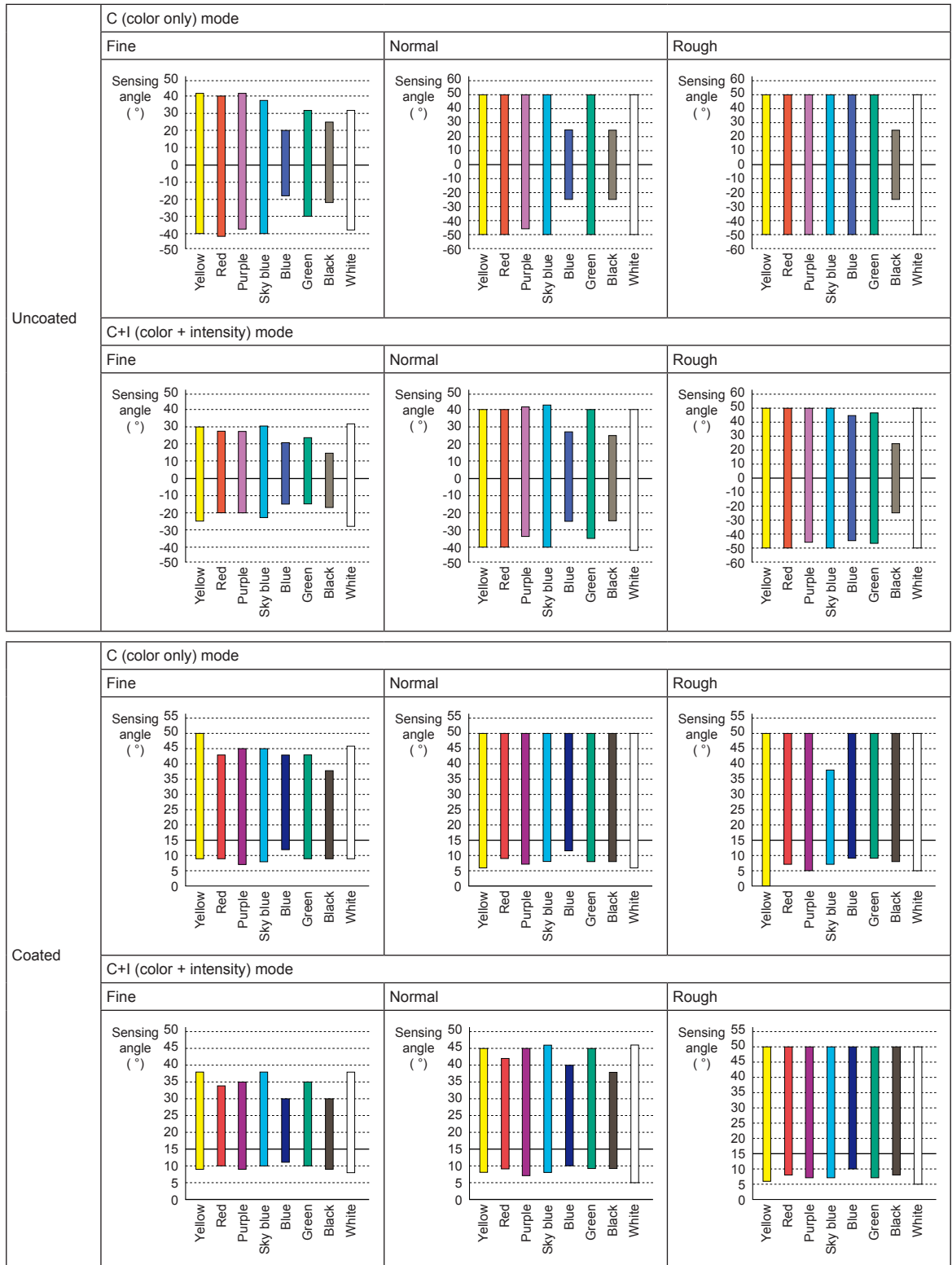

Indicator Display

Status		Operation indicator (red LED)	Stability indicator (green LED)	Teaching indicator (full color LED)	Timer indicator (orange LED)	
					Timer ON	Timer OFF
Normal operation	Stable match	☼	☼	☼ (teaching color)		
	Unstable match	☼	●			
	Unstable mismatch	●	●			
	Stable mismatch	●	☼			
Sensitivity setting (C mode)	Fine	◐	●	◐ (red)		
	Normal			◐ (green)		
	Rough			◐ (blue)		
Sensitivity setting (C+1 mode)	Fine	●	◐	◐ (red)	☼	●
	Normal			◐ (green)		
	Rough			◐ (blue)		
Teaching setting	Teaching standby		●	●	◐ (orange)	
	Normal teaching		☼	☼	☼ (teaching color)	
	Teaching error	Excess light intensity	◐	●	☼ (green)	
		Insufficient light intensity	◐	●	☼ (red)	
		Fluctuating light intensity	◐	●	☼ (blue)	
Timer setting	ON		◐	◐	☼ (teaching color)	☼
	OFF		◐	◐	☼ (teaching color)	●
Overcurrent input		▶	◀	●		●

※Indicator status

☼	ON	●	OFF
◐	Flashing (every 0.5 sec)	▶◀	Flashing alternately (every 0.5 sec)

Troubleshooting

Problem	Cause	Troubleshooting
Will not operate	Power supply	Supply power within rated specifications
	Connection error	Check the cable connections.
Will not operate occasionally	Excess light intensity alarm during teaching, output chattering	Install the sensor at a 10 to 20 degree angle. (when sensing metal or glossy objects)
	Converter external light interference	Install a visor on the sensor or install the unit away from the external light source.
	Contamination of sensor cover	Remove the substance using a soft brush and reset the sensitivity.
	Connector error	Check connector assembly.
Other error	—	Check the display status of the indicators.

(A) Photoelectric Sensors

(B) Fiber Optic Sensors

(C) Door/Area Sensors

(D) Proximity Sensors

(E) Pressure Sensors

(F) Rotary Encoders

(G) Connectors/ Connector Cables/ Sensor Distribution Boxes/Sockets

(H) Temperature Controllers

(I) SSRs / Power Controllers

(J) Counters

(K) Timers

(L) Panel Meters

(M) Tacho / Speed / Pulse Meters

(N) Display Units

(O) Sensor Controllers

(P) Switching Mode Power Supplies

(Q) Stepper Motors & Drivers & Controllers

(R) Graphic/ Logic Panels

(S) Field Network Devices

(T) Software

X-ON Electronics

Largest Supplier of Electrical and Electronic Components

Click to view similar products for [Photoelectric Sensors](#) category:

Click to view products by [Autonics](#) manufacturer:

Other Similar products are found below :

[E3JM-DS70R4T-US](#) [E3L2DC4](#) [E3RA-DN12 2M](#) [E3RA-DP12 2M](#) [E3S5LE4S](#) [E3S-AD38](#) [E3S-CR11 5M](#) [E3SCT11D5M](#) [E3SCT11M1J03M](#)
[E3T-SL14R](#) [E3T-SL24 5M](#) [E3T-ST12R](#) [E3X-CN02](#) [E3X-CN11 5M](#) [E3X-CN21 10M](#) [E3ZM-B66](#) [E3ZM-CL81H 2M](#) [E3Z-T62 2M](#)
[NJL5303R-TE1](#) [PB10CNT15PO](#) [PD60CNX20BP](#) [CX-491-P-J](#) [CX-491-Z](#) [XUM2BKCNL2T](#) [XUM2BKCNL2T](#) [XUM2BNANL2R](#) [Y92E-](#)
[ES30M](#) [Y92E-GS08SS](#) [ZXTDS04T](#) [ZX-XC4A 4M](#) [E3E23Y2US](#) [E3JM-DS70S4-US](#) [E3RA-RN11 2M](#) [E3S5LE42M](#) [E3S-LS20XB4 5M](#)
[E3TFD14N](#) [E3T-FD14R](#) [E3T-SL21 5M](#) [E3T-SL21M](#) [E3T-ST11R](#) [E3T-ST12 5M](#) [E3X-DA41-S-M1J 0.3M](#) [E3X-DAB6](#) [E3X-DAG8](#) [E3ZM-](#)
[B86](#) [E3ZM-CR81 2M](#) [E3ZM-CR86](#) [E3Z-T61A-L 2M](#) [ZX-XGC2R](#) [ZX-XB1A](#)