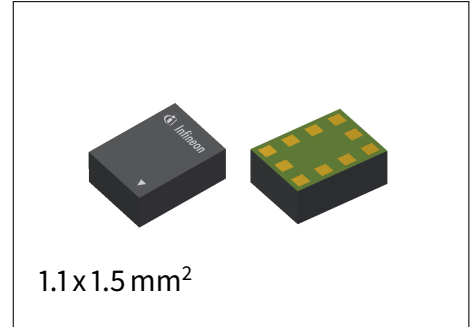


# BGSX22G5A10

## DPDT Antenna Cross Switch

### Features

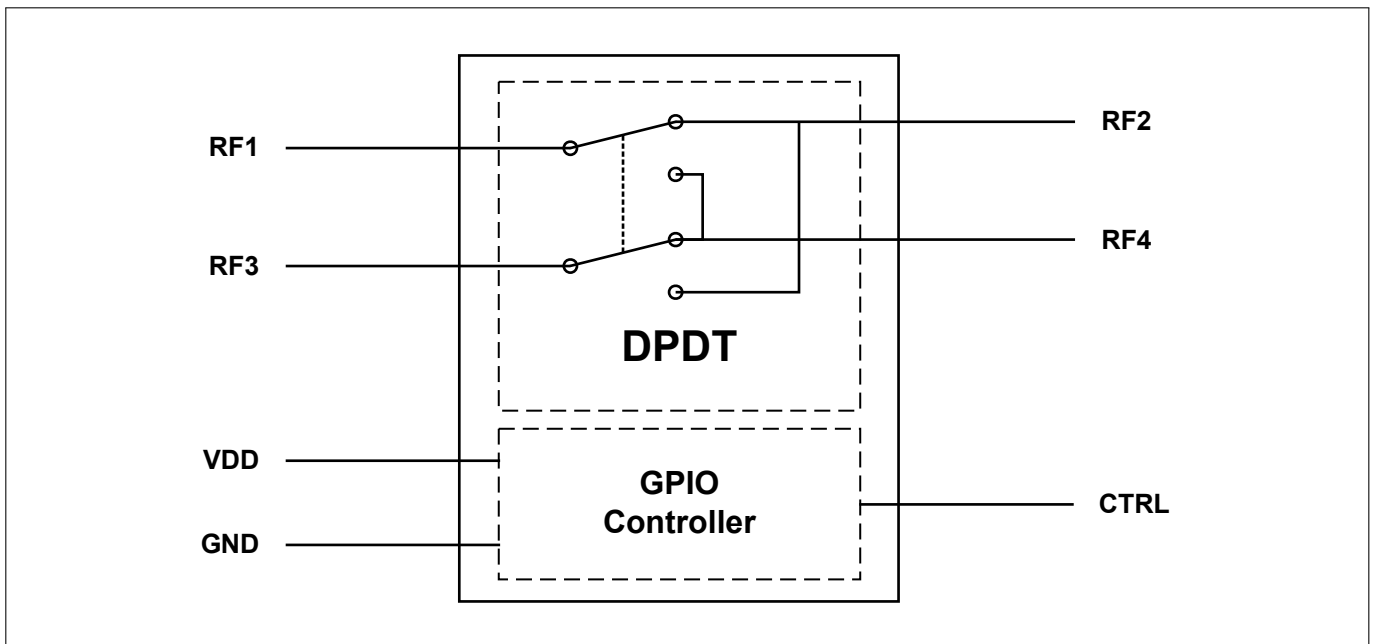
- RF CMOS DPDT antenna cross switch with power handling capability of up to 37 dBm
- Suitable for multi-mode LTE and WCDMA multi antenna applications
- Ultra-low insertion loss and harmonics generation
- 0.1 to 6.0 GHz coverage
- High port-to-port-isolation
- No decoupling capacitors required if no DC applied on RF lines
- General Purpose Input-Output (GPIO) Interface
- Small form factor 1.1mm x 1.5mm
- No power supply blocking required
- High EMI robustness
- RoHS and WEEE compliant package



### Product Validation

Qualified for industrial applications according to the relevant tests of JEDEC47/20/22.

### Block diagram



## Table of Contents

<b>Table of Contents</b>	<b>1</b>
<b>1 Features</b>	<b>2</b>
<b>2 Maximum Ratings</b>	<b>3</b>
<b>3 Operation Ranges</b>	<b>4</b>
<b>4 RF Characteristics</b>	<b>5</b>
<b>5 Modes of Operation</b>	<b>9</b>
<b>6 Application Information</b>	<b>9</b>
<b>7 Package Information</b>	<b>10</b>

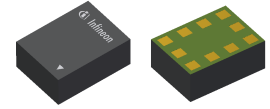
# BGSX22G5A10

## DPDT Antenna Cross Switch

### Features

## 1 Features

- RF CMOS DPDT antenna cross switch with power handling capability of up to 37 dBm
- Suitable for multi-mode LTE and WCDMA multi antenna applications
- Ultra-low insertion loss and harmonics generation
- 0.1 to 6.0 GHz coverage
- High port-to-port-isolation
- No decoupling capacitors required if no DC applied on RF lines
- General Purpose Input-Output (GPIO) Interface
- Small form factor 1.1mm x 1.5mm
- No power supply blocking required
- High EMI robustness
- RoHS and WEEE compliant package



## Description

The BGSX22G5A10 RF MOS switch is specifically designed for LTE and WCDMA triple antenna applications. This DPDT offers low insertion loss and low harmonic generation paired with high isolation between RF ports.

The switch is controlled via a GPIO interface. The on-chip controller allows power-supply voltages from 1.65V to 3.4V.

The switch features direct-connect-to-battery functionality and DC-free RF ports. Unlike GaAs technology, external DC blocking capacitors at the RF Ports are only required if DC voltage is applied externally. The BGSX22G5A10 RF Switch is manufactured in Infineon's patented MOS technology, offering the performance of GaAs with the economy and integration of conventional CMOS including the inherent higher ESD robustness. The device has a very small size of only 1.1 x 1.5mm<sup>2</sup> and a maximum thickness of 0.55mm.

Product Name	Marking	Package
BGSX22G5A10	X5	ATSLP-10-50

Maximum Ratings

**2 Maximum Ratings**

**Table 1: Maximum Ratings Table** at  $T_A = 25\text{ }^\circ\text{C}$ , unless otherwise specified

Parameter	Symbol	Values			Unit	Note / Test Condition
		Min.	Typ.	Max.		
Frequency Range	f	0.1	–	6.0	GHz	1)
Supply voltage <sup>2)</sup>	$V_{DD}$	-0.5	–	3.6	V	–
Storage temperature range	$T_{STG}$	-55	–	150	$^\circ\text{C}$	–
Junction temperature	$T_j$	–	–	125	$^\circ\text{C}$	–
RF input power at all RF ports	$P_{RF}$	–	–	39	dBm	CW / VSWR 1:1 / $50\ \Omega$
ESD capability, CDM <sup>3)</sup>	$V_{ESD\_CDM}$	-1	–	+1	kV	
ESD capability, HBM <sup>4)</sup>	$V_{ESD\_HBM}$	-1	–	+1	kV	
ESD capability, system level <sup>5)</sup>	$V_{ESD\_RF}$	-8	–	+8	kV	RF versus system GND, with 27 nH
Thermal resistance junction - soldering point	$R_{thJS}$	–	–	60	K/W	–
Maximum DC-voltage on RF-Ports and RF-Ground	$V_{RFDC}$	0	–	0	V	No DC voltages allowed on RF-Ports
GPIO control voltage levels	$V_{Ctrlx}$	-0.7	–	$V_{DD}+0.7$ (max. 3.6V)	V	–

<sup>1)</sup>Switch has a lowpass response. For higher frequencies, losses have to be considered for their impact on thermal heating. The DC voltage at RF ports  $V_{RFDC}$  has to be 0V.

<sup>2)</sup>Note: Consider potential ripple voltages on top of  $V_{DD}$ . Including RF ripple,  $V_{DD}$  must not exceed the maximum ratings:  $V_{DD} = V_{DC} + V_{Ripple}$ . Furthermore, high pulse voltages at  $V_{DD}$  pin will cause the ESD structure to trigger.

<sup>3)</sup>Field-Induced Charged-Device Model ANSI/ESDA/JEDEC JS-002. Simulates charging/discharging events that occur in production equipment and processes. Potential for CDM ESD events occurs whenever there is metal-to-metal contact in manufacturing.

<sup>4)</sup>Human Body Model ANSI/ESDA/JEDEC JS-001 (R=1,5 k $\Omega$ , C=100 pF).

<sup>5)</sup>IEC 61000-4-2 (R=330  $\Omega$ , C=150 pF), contact discharge.

**Warning: Stresses above the max. values listed here may cause permanent damage to the device. Maximum ratings are absolute ratings; exceeding only one of these values may cause irreversible damage to the integrated circuit. Exposure to conditions at or below absolute maximum rating but above the specified maximum operation conditions may affect device reliability and life time. Functionality of the device might not be given under these conditions.**

Operation Ranges

### 3 Operation Ranges

**Table 2: Operation Ranges** at  $T_A = -40\text{ }^{\circ}\text{C} \dots 85\text{ }^{\circ}\text{C}$ ,  $P_{IN} = 0\text{ dBm}$ , Supply Voltage  $V_{DD} = 1.65\text{V} \dots 3.4\text{V}$ , unless otherwise specified

Parameter	Symbol	Values			Unit	Note / Test Condition
		Min.	Typ.	Max.		
Supply voltage	$V_{DD}$	1.65	–	3.4	V	–
Supply current	$I_{DD}$	–	55	–	$\mu\text{A}$	–
GPIO control voltage high	$V_{Ctrl\_H}$	1.35	–	$V_{DD} + 0.3$ (max. 3.6V)	V	–
GPIO control voltage low	$V_{Ctrl\_L}$	-0.3	–	0.45	V	–
GPIO control input capacitance	$C_{Ctrl}$	–	–	2	pF	–
Ambient temperature	$T_A$	-40	25	85	$^{\circ}\text{C}$	–

**Table 3: RF Input Power**

Parameter	Symbol	Values			Unit	Note / Test Condition
		Min.	Typ.	Max.		
RF input power	$P_{RF}$	–	–	37	dBm	CW / VSWR 1:1 / $50\ \Omega$

RF Characteristics

**4 RF Characteristics**

**Table 4: RF Characteristics** at  $T_A = 25\text{ }^\circ\text{C}$ ,  $P_{IN} = 0\text{ dBm}$ , Supply Voltage  $V_{DD} = 2.8\text{V}$ , unless otherwise specified

Parameter	Symbol	Values			Unit	Note / Test Condition
		Min.	Typ.	Max.		
<b>Insertion Loss<sup>1)</sup></b>						
All RF ports	IL	-	0.28	0.35	dB	699 to 960MHz
		-	0.37	0.50	dB	1710 to 2200MHz
		-	0.45	0.60	dB	2300 to 2690MHz
		-	0.60	1.20	dB	3300 to 4200MHz
		-	0.80	1.30	dB	4400 to 5000MHz
		-	1.10	1.50	dB	5150 to 5925MHz
<b>Return Loss<sup>1)</sup></b>						
All RF ports	RL	19	24	-	dB	699 to 960MHz
		15	17	-	dB	1710 to 2200MHz
		14	16	-	dB	2300 to 2690MHz
		12	15	-	dB	3300 to 4200MHz
		10	13	-	dB	4400 to 5000MHz
		7	10	-	dB	5150 to 5925MHz

<sup>1)</sup>Measured on application board without any external matching components.

**Table 5: RF Characteristics** at  $T_A = -40\text{ }^\circ\text{C} \dots 85\text{ }^\circ\text{C}$ ,  $P_{IN} = 0\text{ dBm}$ , Supply Voltage  $V_{DD} = 1.65\text{V} \dots 3.4\text{V}$ , unless otherwise specified

Parameter	Symbol	Values			Unit	Note / Test Condition
		Min.	Typ.	Max.		
<b>Insertion Loss<sup>1)</sup></b>						
All RF ports	IL	-	0.28	0.4	dB	699 to 960MHz
		-	0.37	0.6	dB	1710 to 2200MHz
		-	0.45	0.7	dB	2300 to 2690MHz
		-	0.60	1.3	dB	3300 to 4200MHz
		-	0.80	1.4	dB	4400 to 5000MHz
		-	1.10	1.8	dB	5150 to 5925MHz
<b>Return Loss<sup>1)</sup></b>						
All RF ports	RL	19	24	-	dB	699 to 960MHz
		14	17	-	dB	1710 to 2200MHz
		13	16	-	dB	2300 to 2690MHz
		10	15	-	dB	3300 to 4200MHz
		9	13	-	dB	4400 to 5000MHz
		6	10	-	dB	5150 to 5925MHz

<sup>1)</sup>Measured on application board without any external matching components.

# BGSX22G5A10

## DPDT Antenna Cross Switch



### RF Characteristics

**Table 6: RF Characteristics** at  $T_A = -40\text{ }^{\circ}\text{C} \dots 85\text{ }^{\circ}\text{C}$ ,  $P_{IN} = 0\text{ dBm}$ , Supply Voltage  $V_{DD} = 1.65\text{V} \dots 3.4\text{V}$ , unless otherwise specified

Parameter	Symbol	Values			Unit	Note / Test Condition
		Min.	Typ.	Max.		
<b>Isolation<sup>1)</sup></b>						
State 1 RF1-RF3, RF2-RF4	ISO	47	49	-	dB	699 to 960MHz
		41	43	-	dB	1710 to 2200MHz
		39	41	-	dB	2300 to 2690MHz
		37	39	-	dB	3300 to 4200MHz
		36	39	-	dB	4400 to 5000MHz
		34	38	-	dB	5150 to 5925MHz
<b>Isolation<sup>1)</sup></b>						
State 2 RF1-RF3, RF2-RF4	ISO	41	44	-	dB	699 to 960MHz
		35	37	-	dB	1710 to 2200MHz
		33	35	-	dB	2300 to 2690MHz
		31	33	-	dB	3300 to 4200MHz
		31	33	-	dB	4400 to 5000MHz
		33	35	-	dB	5150 to 5925MHz
<b>Isolation<sup>1)</sup></b>						
State 1 RF1-RF4, RF3-RF2	ISO	56	58	-	dB	699 to 960MHz
		49	52	-	dB	1710 to 2200MHz
		48	50	-	dB	2300 to 2690MHz
		44	49	-	dB	3300 to 4200MHz
		41	46	-	dB	4400 to 5000MHz
		38	43	-	dB	5150 to 5925MHz
<b>Isolation<sup>1)</sup></b>						
State 2 RF1-RF2, RF3-RF4	ISO	39	41	-	dB	699 to 960MHz
		32	34	-	dB	1710 to 2200MHz
		31	33	-	dB	2300 to 2690MHz
		28	30	-	dB	3300 to 4200MHz
		28	29	-	dB	4400 to 5000MHz
		29	31	-	dB	5150 to 5925MHz
<b>Harmonic Generation</b>						
H2	P <sub>Harm</sub>	-	-85	-65	dBm	25 dBm, 50 $\Omega$ , CW mode
H3		-	-90	-75	dBm	25 dBm, 50 $\Omega$ , CW mode
H2, GSM LB		-	-70	-55	dBm	35 dBm, 50 $\Omega$ , 50% duty cycle
H3, GSM LB		-	-60	-55	dBm	35 dBm, 50 $\Omega$ , 50% duty cycle
H2, GSM HB		-	-70	-55	dBm	33 dBm, 50 $\Omega$ , 50% duty cycle
H3, GSM HB		-	-60	-55	dBm	33 dBm, 50 $\Omega$ , 50% duty cycle
<b>Intermodulation Distortion IMD2</b>						
IIP2, low	IIP2,l	110	125	-	dBm	IIP2 conditions, Tab. 7
IIP2, high	IIP2,h	110	130	-	dBm	
<b>Intermodulation Distortion IMD3</b>						
IIP3	IIP3	65	80	-	dBm	IIP3 conditions, Tab. 8

<sup>1)</sup> Measured on application board without any external matching components.

# BGSX22G5A10

## DPDT Antenna Cross Switch



### RF Characteristics

**Table 7: IIP2 conditions table**

Band	In-Band Frequency [MHz]	Blocker Frequency 1 [MHz]	Blocker Power 1 [dBm]	Blocker Frequency 2 [MHz]	Blocker Power 2 [dBm]
Band 1 Low	2140	1950	24	190	-10
Band 1 High	2140	1950	24	4090	-10
Band 5 High	880	835	24	1715	-10
Band 7 Low	2655	2535	24	120	-10
Band 7 High	2655	2535	24	5190	-10

**Table 8: IIP3 conditions table**

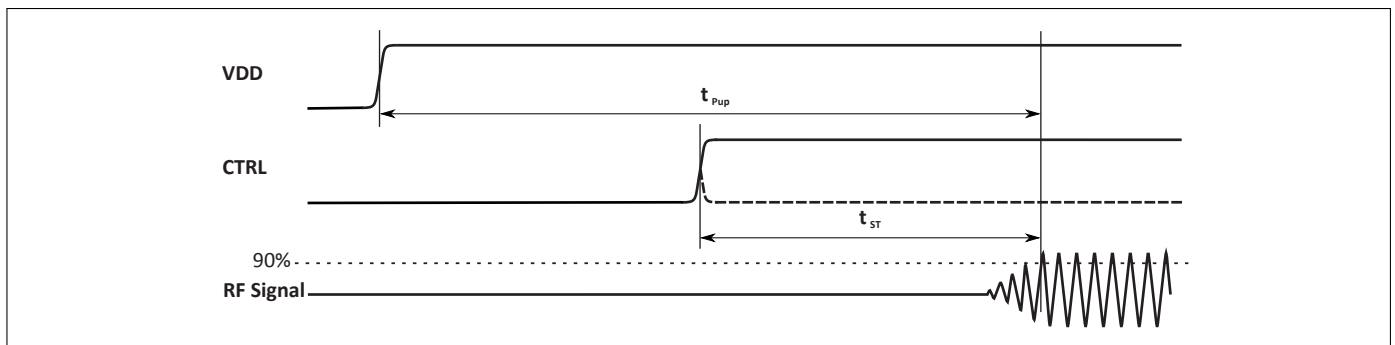
Band	In-Band Frequency [MHz]	Blocker Frequency 1 [MHz]	Blocker Power 1 [dBm]	Blocker Frequency 2 [MHz]	Blocker Power 2 [dBm]
Band 1 Low	2140	1950	24	95	-10
Band 1 Mid	2140	1950	24	1760	-10
Band 1 High	2140	1950	24	6040	-10
Band 5 Low	880	835	24	22.5	-10
Band 5 Mid	880	835	24	790	-10
Band 5 High	880	835	24	2550	-10
Band 7 Low	2655	2535	24	60	-10
Band 7 Mid	2655	2535	24	2415	-10
Band 7 High	2655	2535	24	7725	-10



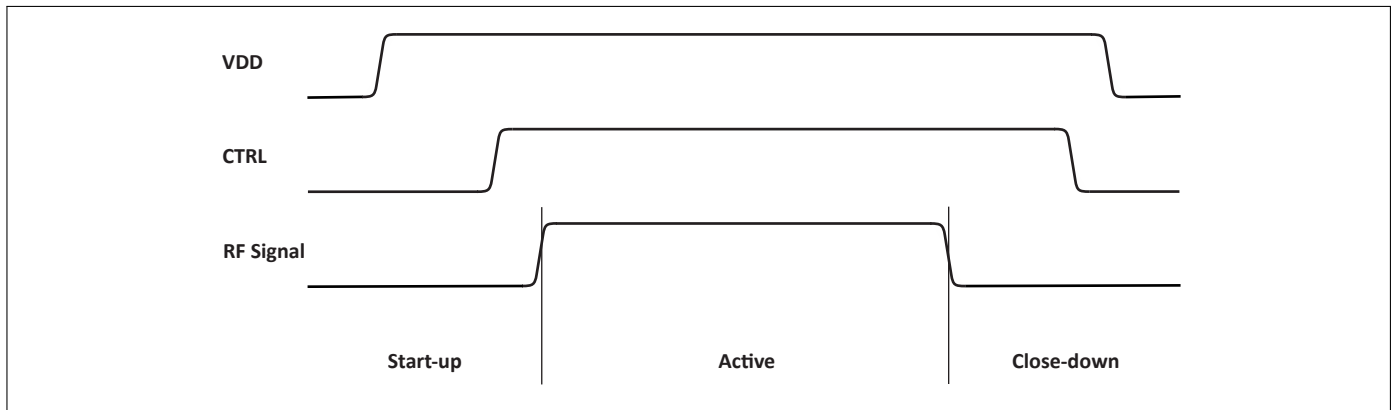
**RF Characteristics**

**Table 9: Switching Time** at  $T_A = 25\text{ }^\circ\text{C}$ ,  $P_{IN} = 0\text{ dBm}$ , Supply Voltage  $V_{DD} = 1.65\text{V} \dots 3.4\text{V}$ , unless otherwise specified

Parameter	Symbol	Values			Unit	Note / Test Condition
		Min.	Typ.	Max.		
<b>Switching Time</b>						
RF Rise Time	$t_{RT}$	-	-	1	$\mu\text{s}$	10 % to 90 % RF signal
Switching Time	$t_{ST}$	-	3	4	$\mu\text{s}$	50 % Ctrl signal to 90 % RF signal
Power Up Settling Time	$t_{Pup}$	-	10	25	$\mu\text{s}$	After power down mode



**Figure 1:** Power Up Settling Time and Switching Time



**Figure 2:** Power On and Off Sequence

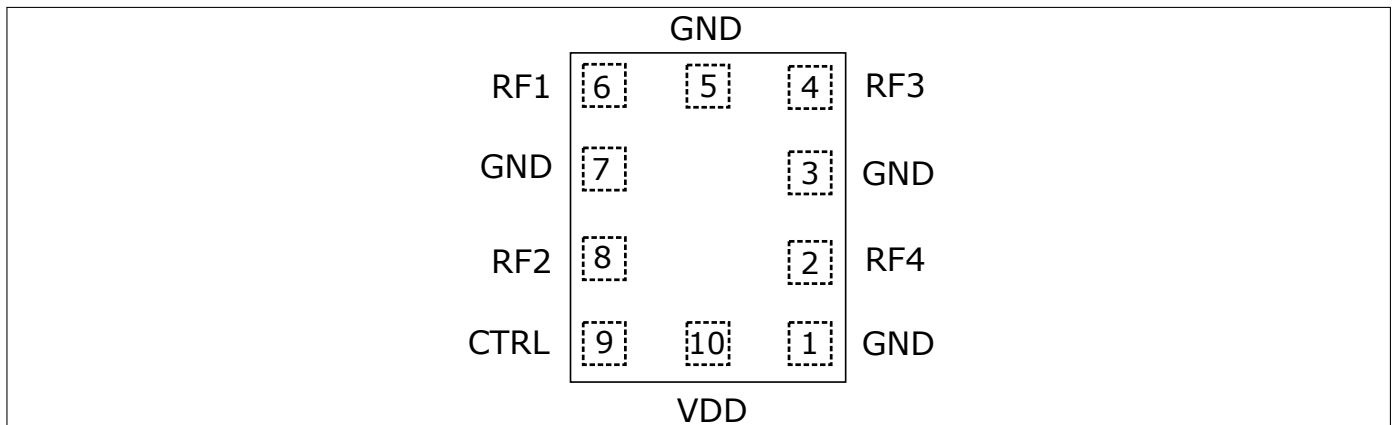
## 5 Modes of Operation

**Table 10: Modes of Operation (Truth Table)**

State	Mode	Control Input
		CTRL
1	RF1 - RF2	0
	RF3 - RF4	
2	RF1 - RF4	1
	RF3 - RF2	

## 6 Application Information

### Pin Configuration and Function



**Figure 3:** BGSX22G5A10 Pin Configuration (top view)

**Table 11: Pin Definition and Function**

Pin No.	Name	Function
1	GND	DC ground
2	RF4	RF port 4
3	GND	RF ground
4	RF3	RF port 3
5	GND	RF ground
6	RF1	RF port 1
7	GND	RF ground
8	RF2	RF port 2
9	CTRL	GPIO control pin
10	VDD	Power supply

# BGSX22G5A10

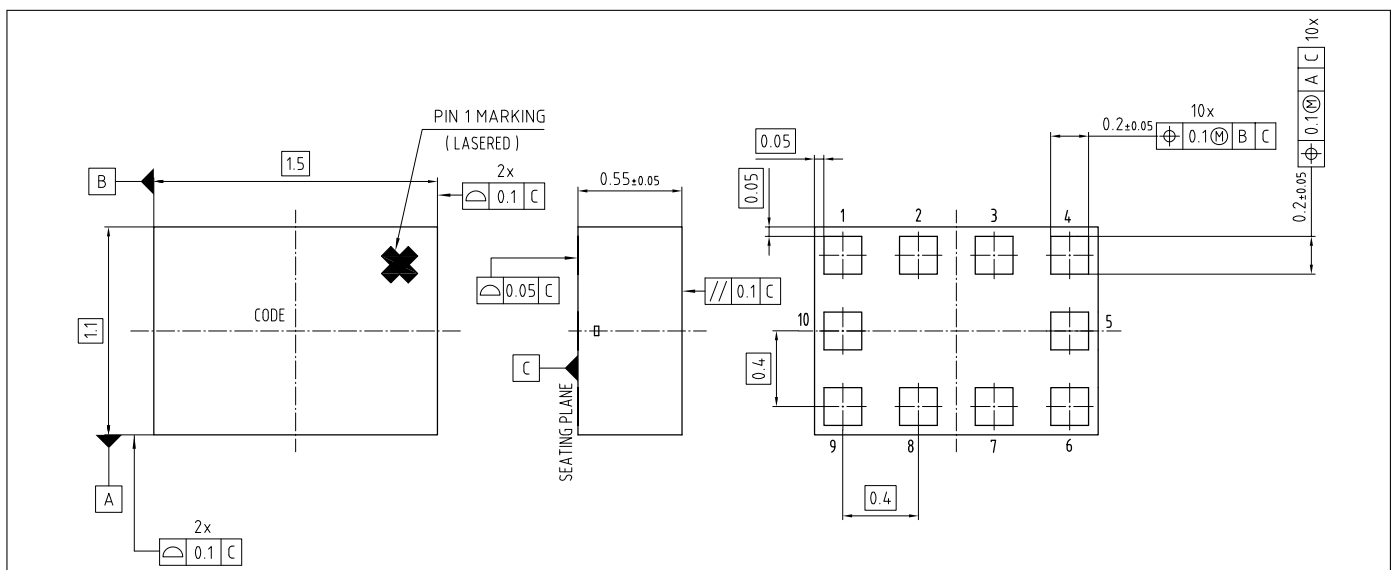
## DPDT Antenna Cross Switch

### Package Information

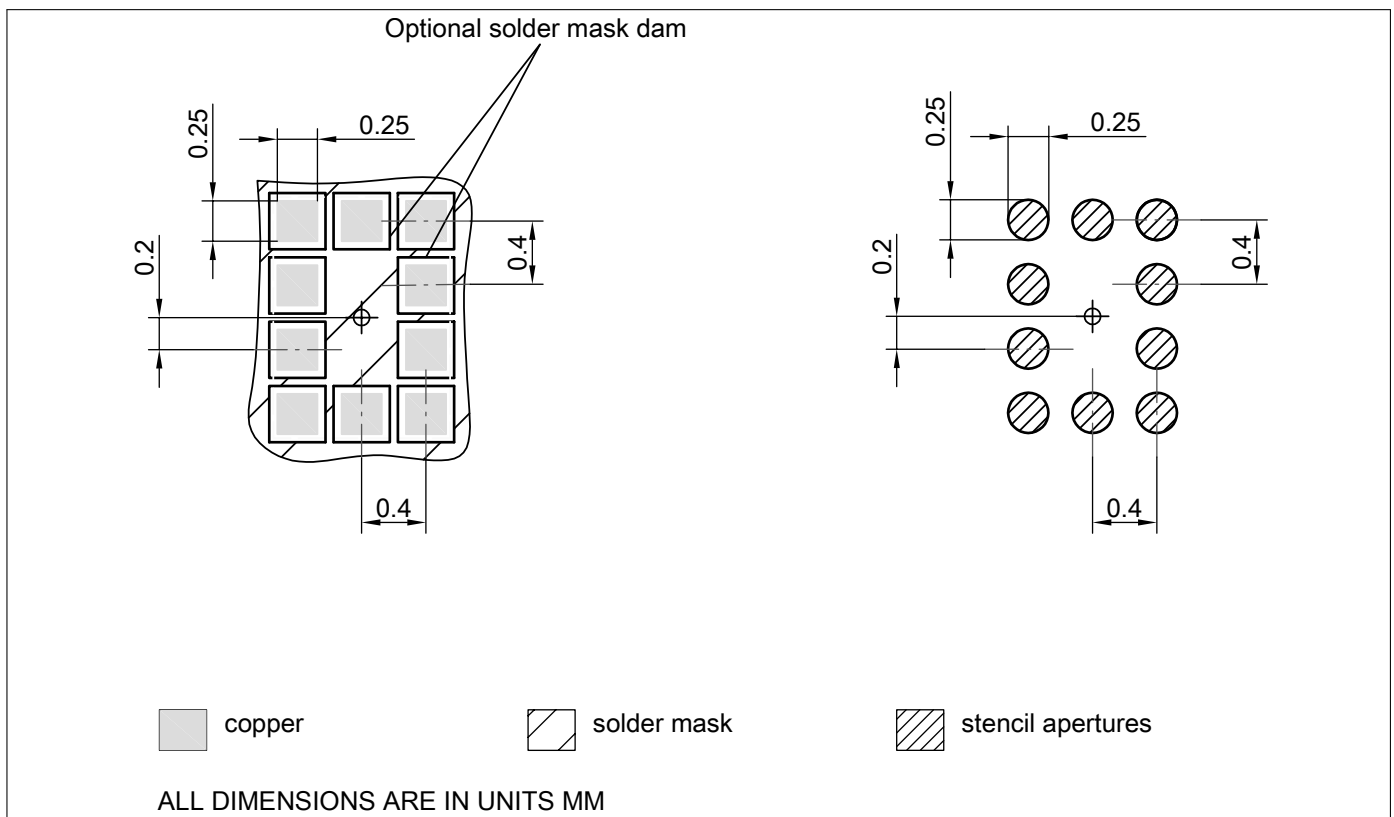
## 7 Package Information

**Table 12: Mechanical Data**

Parameter	Symbol	Value	Unit
X-Dimension	X	1.1 ± 0.05	mm
Y-Dimension	Y	1.5 ± 0.05	mm
Size	Size	1.65	mm <sup>2</sup>
Height	H	0.55 ± 0.05	mm

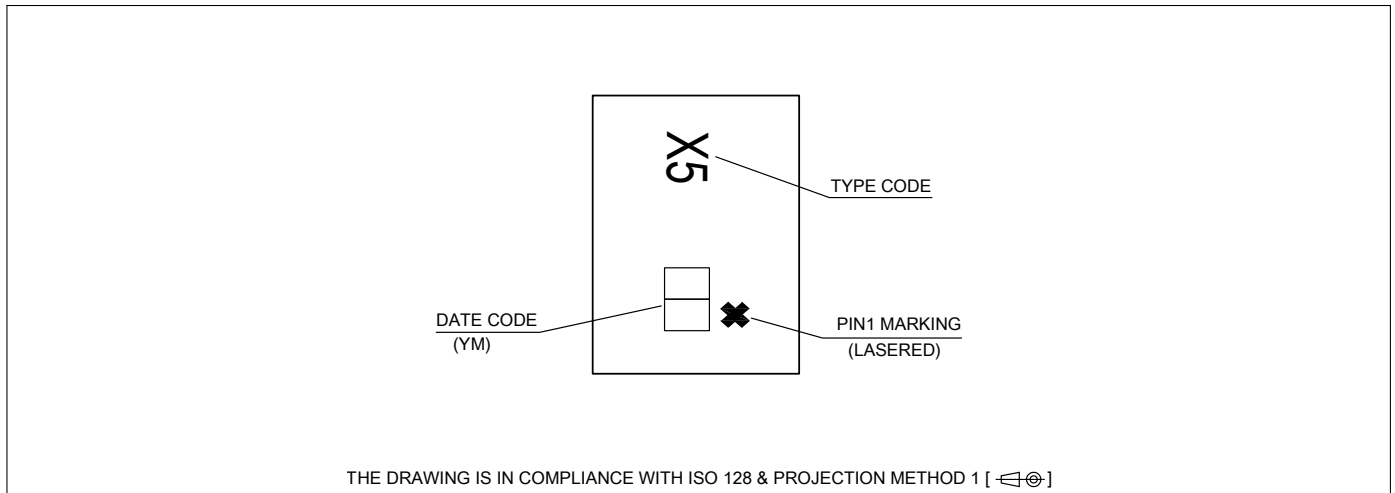


**Figure 4:** ATSLP-10-50 Package Outline (top, side and bottom views)



**Figure 5:** Footprint Recommendation

**Package Information**



**Figure 6:** Marking Specification (top view): Date code digits Y and W defined in Table 13/14

**Table 13: Year date code marking - digit "Y"**

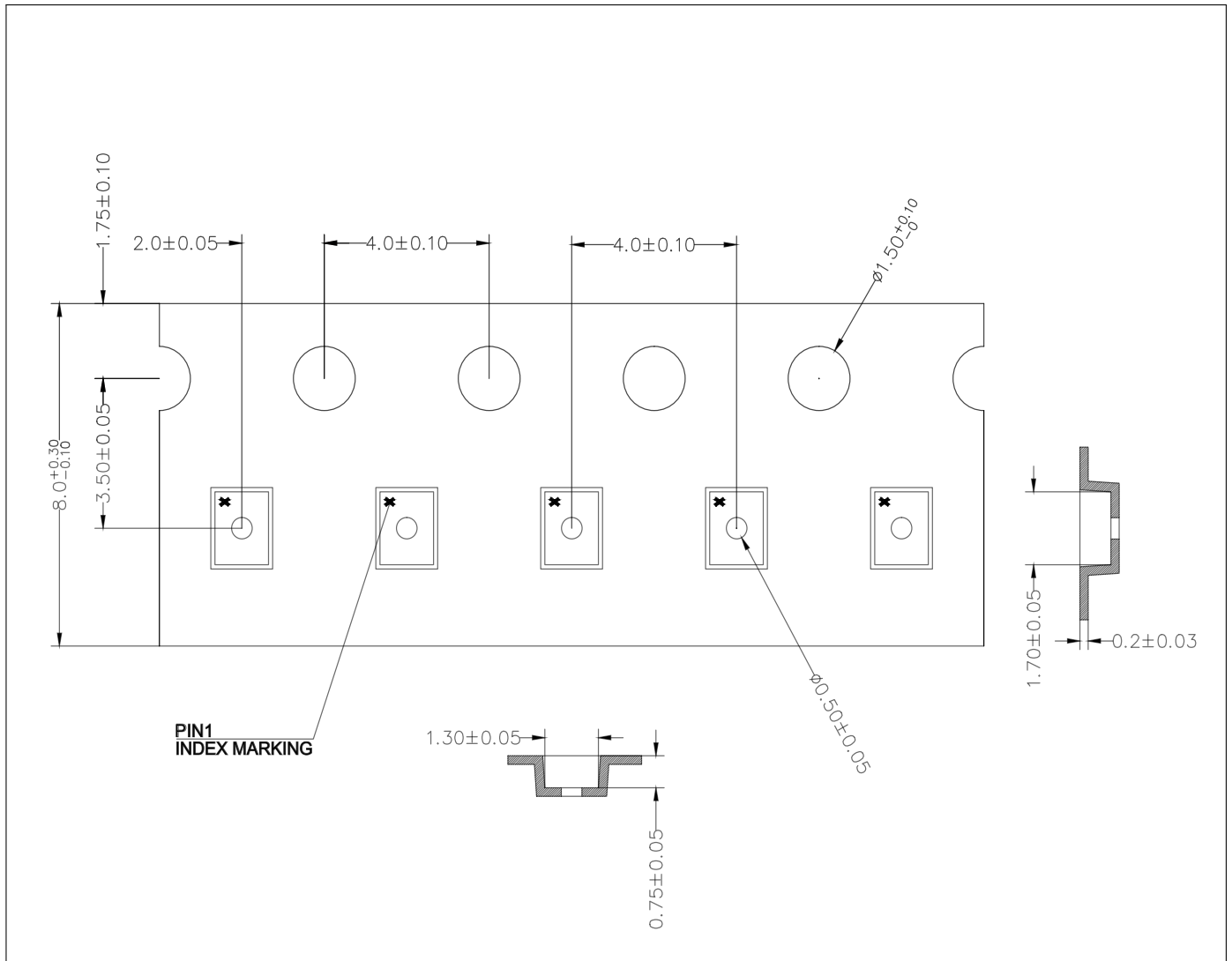
Year	"Y"	Year	"Y"	Year	"Y"
2010	0	2020	0	2030	0
2011	1	2021	1	2031	1
2012	2	2022	2	2032	2
2013	3	2023	3	2033	3
2014	4	2024	4	2034	4
2015	5	2025	5	2035	5
2016	6	2026	6	2036	6
2017	7	2027	7	2037	7
2018	8	2028	8	2038	8
2019	9	2029	9	2039	9

**Table 14: Week date code marking - digit "W"**

Week	"W"	Week	"W"	Week	"W"	Week	"W"	Week	"W"
1	A	12	N	23	4	34	h	45	v
2	B	13	P	24	5	35	j	46	x
3	C	14	Q	25	6	36	k	47	y
4	D	15	R	26	7	37	l	48	z
5	E	16	S	27	a	38	n	49	8
6	F	17	T	28	b	39	p	50	9
7	G	18	U	29	c	40	q	51	2
8	H	19	V	30	d	41	r	52	3
9	J	20	W	31	e	42	s		
10	K	21	Y	32	f	43	t		
11	L	22	Z	33	g	44	u		

**BGSX22G5A10**  
**DPDT Antenna Cross Switch**

**Package Information**



**Figure 7:** ATSLP-10-50 Carrier Tape

---

**Revision History**

<b>Page or Item</b>	<b>Subjects (major changes since previous revision)</b>
---------------------	---

**Revision 8.1, 2018-10-01**

5	RF Characteristics update
---	---------------------------

---

**Trademarks**

All referenced product or service names and trademarks are the property of their respective owners.

**Edition 2018-10-01****Published by****Infineon Technologies AG****81726 Munich, Germany****© 2018 Infineon Technologies AG.****All Rights Reserved.****Do you have a question about any aspect of this document?****Email: [erratum@infineon.com](mailto:erratum@infineon.com)****IMPORTANT NOTICE**

The information given in this document shall in no event be regarded as a guarantee of conditions or characteristics ("Beschaffungsgarantie"). With respect to any examples, hints or any typical values stated herein and/or any information regarding the application of the product, Infineon Technologies hereby disclaims any and all warranties and liabilities of any kind, including without limitation warranties of non-infringement of intellectual property rights of any third party. In addition, any information given in this document is subject to customer's compliance with its obligations stated in this document and any applicable legal requirements, norms and standards concerning customer's products and any use of the product of Infineon Technologies in customer's applications. The data contained in this document is exclusively intended for technically trained staff. It is the responsibility of customer's technical departments to evaluate the suitability of the product for the intended application and the completeness of the product information given in this document with respect to such application.

For further information on technology, delivery terms and conditions and prices, please contact the nearest Infineon Technologies Office ([www.infineon.com](http://www.infineon.com)).

**WARNINGS**

Due to technical requirements products may contain dangerous substances. For information on the types in question please contact your nearest Infineon Technologies office.

Except as otherwise explicitly approved by Infineon Technologies in a written document signed by authorized representatives of Infineon Technologies, Infineon Technologies products may not be used in any applications where a failure of the product or any consequences of the use thereof can reasonably be expected to result in personal injury.

## X-ON Electronics

Largest Supplier of Electrical and Electronic Components

*Click to view similar products for [Analogue Switch ICs category](#):*

*Click to view products by [Infineon manufacturer](#):*

Other Similar products are found below :

[FSA3051TMX](#) [NLVAS4599DTT1G](#) [MAX4992EVB+T](#) [MAX4684ETB+T](#) [BCM6522IPBG](#) [BCM65300IFSBG](#) [MAX14764ETA+T](#)  
[TMUX1113RSVR](#) [TMUX1112RSVR](#) [ADG1436TRUZ-EP](#) [BL4684C](#) [PE423422A](#) [PE42359SCAA](#) [PE42540F](#) [RS550YUCM12](#)  
[ADGS1414DBCCZ](#) [ADG658YRUZ-REEL7](#) [RS2117YUTQK10](#) [RS2118YUTQK10](#) [RS2227XUTQK10](#) [SP2526A-1EN-L/TR](#) [FSA4157P6X](#)  
[BA7603F-E2](#) [MAX4702EUE+](#) [MAX4617CUE+](#) [MAX4599EUT+T](#) [MAX4066ESD+](#) [MAX4052ACSE+](#) [MAX396CAI+](#) [MAX391CPE+](#)  
[MAX4730EXT+T](#) [MAX314CPE+](#) [MAX4051AEEE+](#) [BU4066BCFV-E2](#) [MAX313CPE+](#) [BU4S66G2-TR](#) [TS3A4751PWR](#)  
[NCN1154MUTAG](#) [DG444DY-E3](#) [NLAS4157DFT2G](#) [NLAS4599DFT2G](#) [NLAS7242MUTBG](#) [NLASB3157DFT2G](#) [NLAST4599DFT2G](#)  
[NLAST4599DTT1G](#) [DG403DY-T1-E3](#) [MAX4714EXTT](#) [MAX392CPE](#) [BGSX22G2A10E6327XTSA1](#) [ADG1611BRUZ-REEL7](#)