



DPM 8000 Series-2 Voltmeters and Ammeters



Models covered by this instruction sheet

• DPM8100-2	3.5 DIGIT 200mV DC
• DPM8100A-2	3.5 DIGIT 2V DC
• DPM8120-2	3.5 DIGIT 200mV AC
• DPM8120A-2	3.5 DIGIT 2V AC
• DPM8140-2	3.5 DIGIT 200mV True RMS AC
• DPM8400-2	4.5 DIGIT 200mV DC
• DPM8400A-2	4.5 DIGIT 2V DC
• DPM8420-2	4.5 DIGIT 200mV AC
• DPM8420A-2	4.5 DIGIT 2V AC

The DPM8100-2 and DPM8400-2 series can be ranged as voltmeters or ammeters by fitting multiplier or shunt resistors (not include into the labelled positions on the main printed circuit board as shown on the diagram overleaf. Wire links "JP1" may need to be removed for some voltmeter ranges.

Using close tolerance resistors, the minimum of recalibration is required. For accurate setting a calibrated supply should be used. The resistors fitted should be adequately rated for the current or voltage range.

For non standard ranging and calibration, application sheet No. AES040 is available on request.

Over range is indicated by -1 on the display for 3.5 digit meters and by flashing zero's on the 4.5 digit meters.

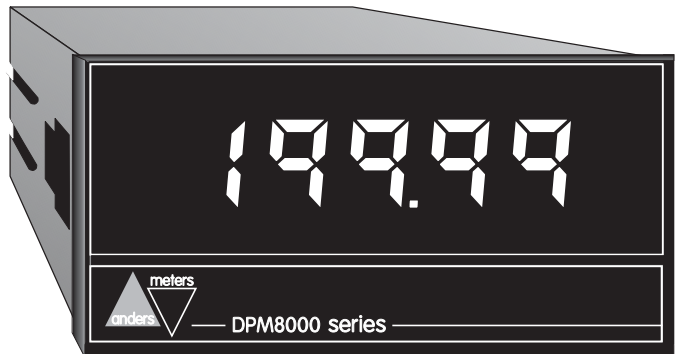

OPERATING SPECIFICATION

Accuracy:	81xx: +/- 0.1% of rdg +/-1 digit (AC models +/- 0.2%) 84xx: +/- 0.01% of rdg +/-2 digits DC models 84xx: +/- 0.1% of rdg +/-3 digits AC models
Line voltage:	115/ 230 volts +10, -20%, 50 - 60 Hz
Temperature:	0 - 50 degrees C
Humidity:	below 85% RH
Power:	4VA
Sampling rate:	2.5 / second

TERMINAL DEFINITIONS

	SYMBOL	DESCRIPTION
1	IN HI	Apply input to pins 1 and 2. If INLO signal is greater than INHI the display will read -ive.
2	IN LO	
3	n/c	Not connected (unused)
4	Gnd (sig)	digital 0 Volts (NOT MAINS EARTH)
5	HOLD (display)	connect to terminal 6 (+5V) 8100 series connect to terminal 4 (0V) 8400 series
6	+5V (o/p)	internal +5V output (maximum 50mA)
7	230V	AC mains supply
8	115V	
9	0V (N)	

DIMENSIONS

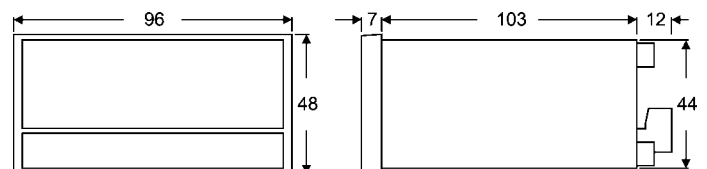

Panel cut out 92 x 45 mm

INSTALLATION DIAGRAM

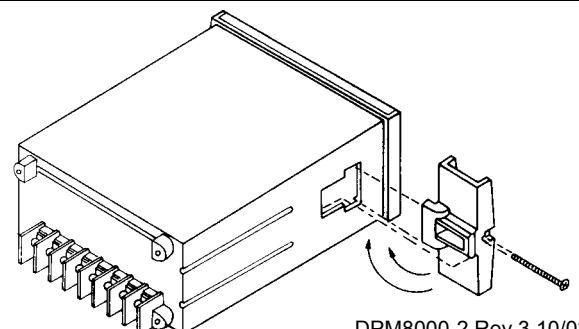

DPM8000-2 Rev 3 10/03

STEP BY STEP INSTRUCTIONS

1	Remove instrument from its protective plastic bag and clip off front cover.
2	Pull off the three green safety terminals from the rear of the meter. The complete panel meter assembly can now be removed from its case by carefully levering the base of the LED display board over the plastic retaining lug while pushing gently on the terminal pins at the rear.
3	With reference to the Range Specification table and notes overleaf, determine the resistance values to be fitted for the required voltage or current range. Further note whether link "JP1" should be removed. Carefully de-solder and remove link JP1 if necessary and solder the required resistors in place as shown on the main circuit board diagram.
4	The decimal point should be set as required by either repositioning the PCB jumper link JP2 on the 3.5 digit models or setting a dip switch on the front of the 4.5 digit model, in one of these locations:- DP1 gives 1.999 i.e. .XXX DP2 gives 19.99 i.e. X.XX DP3 gives 199.9 i.e. XX.X DP4 gives 1999.9 i.e. XXX.X on 4.5 digit version only.
5	Slide panel meter back into its case along the guide rails taking care to ease bottom of LED display board over protruding lug. Then push the green safety terminals securely back into place on the rear of the meter.
6	Make electrical connection to the meter with reference to the Terminal Definition table. Note Mains Earth must NOT be connected to pin 4. There is no earth connection required with this meter. Note also that Pin 3 is unused.
7	The instrument may now be tested. For improved accuracy it can be adjusted by turning the "span adj" potentiometer whilst applying full scale signal from a calibrated source until exactly full scale is shown on the display. On the DPM8140 and DPM8400 only, first set the display to read zero for 0V input using the "offset" potentiometer on the front left hand side of the board.
8	Finally, clip the cover back on and insert the meter into the panel cut-out. "Snap" the mounting clips into the side of the case (refer to installation diagram) and tighten the fixing screws until secure in the panel - do not over tighten!

PCB LAYOUT

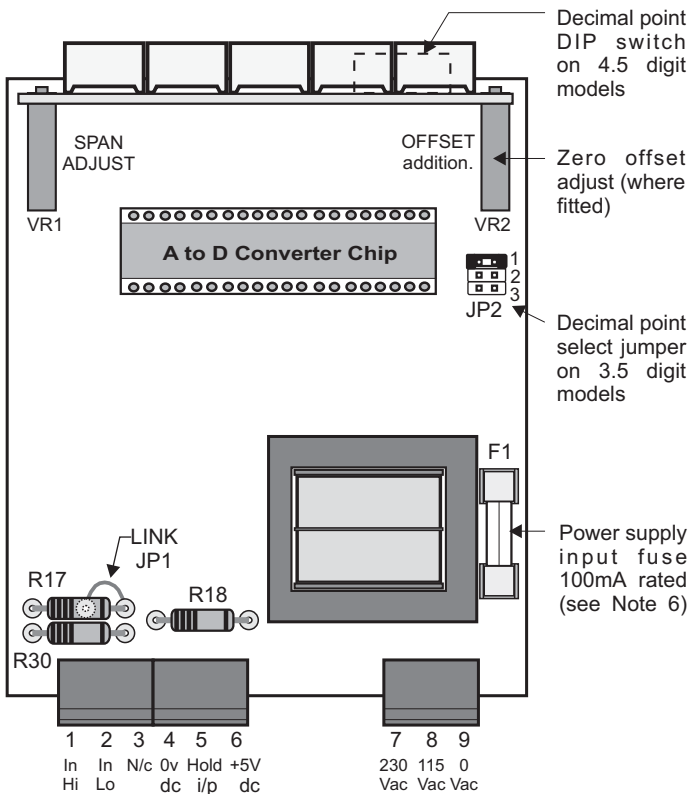

! Warning:
Make **no** connection from pin 4 to mains earth under any conditions.

Important
Observe the mains input connections

NOTES

- To measure voltages above the meters basic sensitivity, attenuator resistors R17 and R18 need to be installed. The general equation to determine their values is given by: $V_{IN} = V_D \times (1 + R_{17}/R_{18})$ Where V_{IN} is the input voltage required and V_D is the corresponding display voltage. Note, V_D max is actually 199.9mV for a nominal 200mV basic sensitivity meter and 1.999V for a nominal 2V meter

V_{IN}	Display	V_D	R17	R18
20V	19.99V	1.999V	1M	110K
10V	1500rpm	1.5V	1M	176K

For standard input ranges choose the corresponding resistors from the range specification table below.
- For inputs greater than 200V, R17 must be a high voltage resistor such as Philips VR37 Series (1x2M2, 0.5W, RS164-8316) with R18=2k2. Alternatively, use two carbon film resistors in series, such as Multicomp MCF (2x1M2, 0.5W, Farnell 262-195) with R18 as 2K4. See the options for R17 below. The maximum input voltage on this range with correct resistors is 650V.
- For ranges of 200V or less, for R17, use metal film resistors, 1%, 0.5W as Farnell 545-314. For basic 200mV use only existing link JP1
- For R18, on all voltage ranges, use metal film resistors, 1%, 0.25W
- On current ranges, use metal film resistors, 0.5W for R30. The current, using internal shunt resistor R30 must not exceed 2 Amps. Leave link JP1 in place
- The power supply input protection fuse is a 20mm cartridge type rated at 250V/ 100mA.

Options for Resistor R17

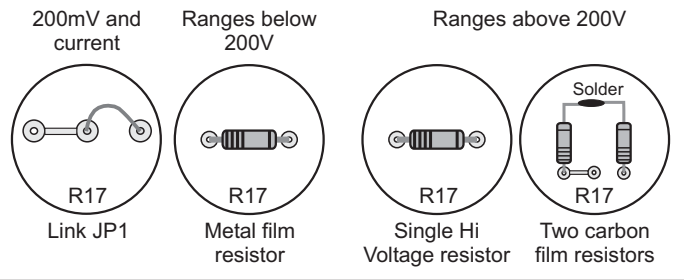

RANGE SPECIFICATION

MODEL NUMBER	RESOLUTION (of range required)	BASIC SENSITIVITY	RANGE REQUIRED	OVERLOAD PROTECTION	R17	R18	R30	LINK JP1	INPUT IMPEDANCE
8100, 8120, 8140 8400, 8420	100 V 10 V	200mV	0.2V	100V	—	—	—	IN	>100M
8100, 8120, 8140 8400, 8420	1mV 100 V	200mV	2V	100V	1M	110K	—	OUT	1M
8100, 8120, 8140 8400, 8420	10mV 1mV	200mV	20V	300V	1M	10K	—	OUT	1M
8100A, 8120A 8400A, 8420A	1mV 100 V	2V	2V	100V	—	—	—	IN	>100M
8100A, 8120A 8400A, 8420A	10mV 1mV	2V	20V	100V	1M	110K	—	OUT	1M
8100A, 8120A 8400A, 8420A	100mV 10mV	2V	200V	300V	1M	10K	—	OUT	1M
8100A, 8120A 8400A, 8420A	1V 100mV	2V	650V (see note 2)	700V	2M2	2K2	—	OUT	2M2
8100, 8120, 8140 8400, 8420	0.1 A 10nA	200mV	200 A	DO NOT EXCEED DISSIPATION RATING OF SHUNT RESISTOR RC (SEE NOTE 5)	—	—	1K	IN	1k
8100, 8120, 8140 8400, 8420	1 A 0.1 A	200mV	2mA		—	—	100R	IN	100R
8100, 8120, 8140 8400, 8420	10 A 1 A	200mV	20mA		—	—	10R	IN	10R
8100, 8120, 8140 8400, 8420	100 A 10 A	200mV	200mA		—	—	1R	IN	1R
8100, 8120, 8140 8400, 8420	1mA 100 A	200mV	2A		—	—	0R1	IN	R1 (0.1)

X-ON Electronics

Largest Supplier of Electrical and Electronic Components

Click to view similar products for [Anderson Power](#) manufacturer:

Other Similar products are found below :

[Anderson Power](#)