



ARM Cortex-A8 System On Module

GCS2 SERIES DATASHEET



V1.2
GRINN 2016

Table of Contents

1.	Summary	3
1.1.	Features	3
1.2.	Applications.....	3
1.3.	Description	3
2.	Functional Description	4
2.1.	Block Diagram.....	4
2.2.	AM335X Microprocessors	5
2.3.	Power Management IC	5
2.4.	IC SDRAM DDR3 Memory.....	5
2.5.	NAND Flash Memory	5
3.	Terminal Description.....	6
3.1.	Pinout.....	6
3.2.	Boot Configuration Pins	12
4.	Electrical Characteristics.....	12
4.1.	Absolute Maximum Ratings	12
4.2.	Recommended Operating Conditions	12
5.	Mechanical Characteristics	13
6.	Ordering Information	14
6.1.	Nomenclature.....	14
6.2.	Order table.....	14
7.	Reference Documentation	15
8.	Document Revision History.....	15

1. Summary

1.1. Features

- Fast time to market
- Reduction of production costs
- Tiny size - 40mm x 40mm x 2.6mm
- Direct assembly to PCB
- Universal for multiple projects
- Single power supply
- Fast and high-performance processor
- Easy EMC/EMI certification
- Low heat emission

1.2. Applications

- Industrial Automation
- Home/Building Automation
- Medical Appliances
- HMI panels
- Internet of Things
- Metering Gateways
- Consumer Electronics

1.3. Description

The chiliSOM is an ultra-small, extremely low-power, state-of-art module based on ARM Cortex-A8 processor. Modular design makes it easy to embed to your device without any connector. By placing the most critical signals in the module, even very complex peripherals can be placed using two PCB layers. This allows a significant reduction in production costs. ChiliSOM is ideally suitable for applications requiring high degree of density and high computational power at extremely low power consumption. The module is designed to operate with all major OS. It is preconfigured for Linux and Android. With a rich set of peripherals the module is designed to cater for a wide range of applications.

2. Functional Description

2.1. Block Diagram

chiliSOM functional block diagram is shown on Figure 1.

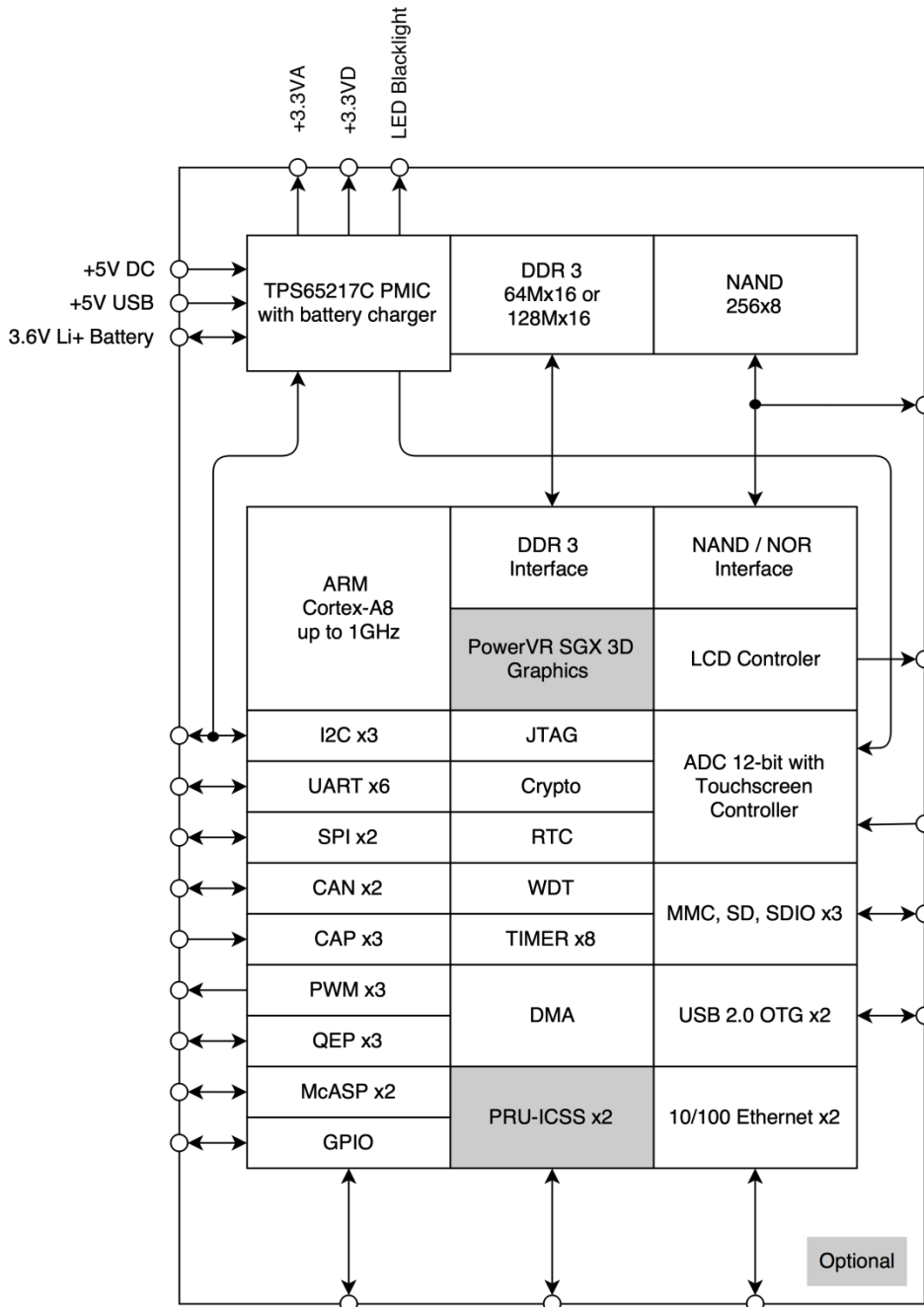

Figure 1 ChiliSOM Functional Block Diagram

2.2. AM335X Microprocessors

The chiliSOM is based on Texas Instruments AM335X microprocessor in 324 ball BGA package. It's powered by ARM Cortex-A8 core with MMU, floating point unit and multimedia NEON instruction set. Optional 3D graphics acceleration enhances multimedia applications.

2.3. Power Management IC

The chiliSOM has TPS65217C Power Management IC on-board dedicated to AM335X microprocessor. It provides step-down converters for powering processor core and DDR3 memory, four LDO for other microprocessor requirements, one step-up converter dedicated for LCD LED backlight and Li-Ion or Li-Poly battery charger. PMIC is controlled by AM335X I2C0 interface available at ChiliSOM terminals (I2C0_SCL and I2C0_SDA), so they cannot be used for other function than I2C0. TPS65217C I2C address is 0x24. PMIC LDO2 is available at pin 3.3VA with maximum current output of 100mA. LDO4 is also available at pin 3.3VD with maximum current output of 400mA, but this voltage is also used by AM335X and NAND Flash memory, so current output in typical application is reduced to 200mA. If base board components connected to ChiliSOM is powered from other voltage domain, this voltage has to be controlled by 3.3VA terminal because any external voltage applied to ChiliSOM in shutdown state may cause permanent damage to module. TPS65217C MUX_OUT terminal is internally connected to ADC AIN7 channel (ball C9 in AM335X ZCZ package) on ChiliSOM. It can be used to monitor battery voltage, system voltage, battery temperature and charging current.

2.4. IC SDRAM DDR3 Memory

The chiliSOM is available with up to 4 GB of DDR3 memory. RAM is connected to AM335X using 16-bit interface running at frequency up to 400MHz, giving theoretical bandwidth of 12.8Gbit/s.

2.5. NAND Flash Memory

The chiliSOM is available with 256Mx8bit NAND Flash memory. This memory internally is connected to AM335X microprocessor using GPMC 8-bit bus. Whole 16-bit GPMC bus is available for connection with external memories / peripherals, but pins connected to NAND Flash cannot be used for other function than GPMC (GPMC_AD[7:0], GPMC_WE, GPMC_OE_RE GPMC_BE0_CLE, GPMC_ADV_ALE, GPMC_WP and GPMC_WAIT). Block 0 of the memory is valid when shipped, and requires 1-bit ECC if program/erase cycles are less than 1000.

3. Terminal Description

3.1. Pinout

Table below shows chiliSOM pin assignments. For complete multifunction pins description refers to section 2.2 in AM335X datasheet.

Pin No	Name	Type	AM335X ZCZ Ball	Description
1, 2	V_DC	Power Input		+5V DC power supply input.
5, 6	V_USB	Power Input		+5V USB power supply input.
3, 4, 9, 18, 27, 36, 45, 55, 68, 78, 85, 91, 97, 109, 118, 121, 130, 135, 143, 147, 156, 164, 174, 175, 179, 180	GND	Ground		Power ground.
7	PWR_BTN	Input 3.3V		Power push-button input. Typically connected to a momentary switch to ground (active low).
8	WARM_RST	IO 3.3V	A10	AM335X reset (active low). This pin has internal 10k pull-up to 3.3V.
10	LCD_DATA0/ SYSBOOT0(1)	IO 3.3V	R1	Multifunction pin and boot configuration.
11	LCD_DATA1/ SYSBOOT1(1)	IO 3.3V	R2	Multifunction pin and boot configuration.
12	LCD_DATA2/ SYSBOOT2(1)	IO 3.3V	R3	Multifunction pin and boot configuration.
13	LCD_DATA3/ SYSBOOT3(1)	IO 3.3V	R4	Multifunction pin and boot configuration.
14	LCD_DATA4/ SYSBOOT4(1)	IO 3.3V	T1	Multifunction pin and boot configuration.
15	LCD_DATA5/ SYSBOOT5(1)	IO 3.3V	T2	Multifunction pin and boot configuration.
16	LCD_DATA6/ SYSBOOT6(1)	IO 3.3V	T3	Multifunction pin and boot configuration.
17	LCD_DATA7/ SYSBOOT7(1)	IO 3.3V	T4	Multifunction pin and boot configuration.
19	LCD_DATA8/ SYSBOOT8(1)	IO 3.3V	U1	Multifunction pin and boot configuration.
20	LCD_DATA9/ SYSBOOT9(1)	IO 3.3V	U2	Multifunction pin and boot configuration.
21	LCD_DATA10/ SYSBOOT10(1)	IO 3.3V	U3	Multifunction pin and boot configuration.
22	LCD_DATA11/ SYSBOOT11(1)	IO 3.3V	U4	Multifunction pin and boot configuration.
23	LCD_DATA12/ SYSBOOT12(1)	IO 3.3V	V2	Multifunction pin and boot configuration.

24	LCD_DATA13/ SYSBOOT13(1)	IO 3.3V	V3	Multifunction pin and boot configuration.
25	LCD_DATA14/ SYSBOOT14(1)	IO 3.3V	V4	Multifunction pin and boot configuration.
26	LCD_DATA15/ SYSBOOT15(1)	IO 3.3V	T5	Multifunction pin and boot configuration.
28	LCD_PCLK	IO 3.3V	V5	Multifunction pin.
29	LCD_HSYNC	IO 3.3V	R5	Multifunction pin.
30	LCD_VSYNC	IO 3.3V	U5	Multifunction pin.
31	LCD_AC_BIAS_EN	IO 3.3V	R6	Multifunction pin.
32	GPMC_WE(2)	IO 3.3V	U6	Multifunction pin, connected to NAND Flash memory.
33	GPMC_BE0_CLE(2)	IO 3.3V	T6	Multifunction pin, connected to NAND Flash memory.
34	GPMC_OE_RE(2)	IO 3.3V	T7	Multifunction pin, connected to NAND Flash memory.
35	GPMC_ADV_ALE(2)	IO 3.3V	R7	Multifunction pin, connected to NAND Flash memory.
37	GPMC_AD0(2)	IO 3.3V	U7	Multifunction pin, connected to NAND Flash memory.
38	GPMC_AD1(2)	IO 3.3V	V7	Multifunction pin, connected to NAND Flash memory.
39	GPMC_AD2(2)	IO 3.3V	R8	Multifunction pin, connected to NAND Flash memory.
40	GPMC_AD3(2)	IO 3.3V	T8	Multifunction pin, connected to NAND Flash memory.
41	GPMC_AD4(2)	IO 3.3V	U8	Multifunction pin, connected to NAND Flash memory.
42	GPMC_AD5(2)	IO 3.3V	V8	Multifunction pin, connected to NAND Flash memory.
43	GPMC_AD6(2)	IO 3.3V	R9	Multifunction pin, connected to NAND Flash memory.
44	GPMC_AD7(2)	IO 3.3V	T9	Multifunction pin, connected to NAND Flash memory.
46	GPMC_CLK	IO 3.3V	V12	Multifunction pin.
47	GMPC_AD8	IO 3.3V	U10	Multifunction pin.
48	GMPC_AD9	IO 3.3V	T10	Multifunction pin.
49	GMPC_AD10	IO 3.3V	T11	Multifunction pin.
50	GMPC_AD11	IO 3.3V	U12	Multifunction pin.
51	GMPC_AD12	IO 3.3V	T12	Multifunction pin.
52	GMPC_AD13	IO 3.3V	R12	Multifunction pin.
53	GMPC_AD14	IO 3.3V	V13	Multifunction pin.
54	GMPC_AD15	IO 3.3V	U13	Multifunction pin.
56	GPMC_A0	IO 3.3V	R13	Multifunction pin.
57	GPMC_A1	IO 3.3V	V14	Multifunction pin.

58	GPMC_A2	IO 3.3V	U14	Multifunction pin.
59	GPMC_A3	IO 3.3V	T14	Multifunction pin.
60	GPMC_A4	IO 3.3V	R14	Multifunction pin.
61	GPMC_A5	IO 3.3V	V15	Multifunction pin.
62	GPMC_A6	IO 3.3V	U15	Multifunction pin.
63	GPMC_A7	IO 3.3V	T15	Multifunction pin.
64	GPMC_A8	IO 3.3V	V16	Multifunction pin.
65	GPMC_A9	IO 3.3V	U16	Multifunction pin.
66	GPMC_A10	IO 3.3V	T16	Multifunction pin.
67	GPMC_A11	IO 3.3V	V17	Multifunction pin.
69	GPMC_BE1	IO 3.3V	U18	Multifunction pin.
70	GPMC_WP	IO 3.3V	U17	Multifunction pin.
71	GPMC_WAIT(2)	IO 3.3V	T17	Multifunction pin, connected to NAND Flash memory.
72	GPMC_CS1	IO 3.3V	U9	Multifunction pin.
73	GPMC_CS2	IO 3.3V	V9	Multifunction pin.
74	GPMC_CS3	IO 3.3V	T13	Multifunction pin.
75	USB1_VBUS	Input	T18	USB1 VBUS sense input.
76	USB1_D_n	IO	R18	USB1 data minus.
77	USB1_D_p	IO	R17	USB1 data plus.
79	USB1_ID	Input	P17	USB1 OTG ID input.
80	USB1_CE	Output 3.3V	P18	USB1 charger enable (active high).
81	USB1_DRVVBUS	IO 3.3V	F15	USB1 VBUS control output (active high).
82	USB0_VBUS	Input	P15	USB0 VBUS sense input.
83	USB0_D_n	IO	N18	USB0 data minus.
84	USB0_D_p	IO	N17	USB0 data plus..
86	USB0_ID	Input	P16	USB0 OTG ID input.
87	USB0_CE	Output 3.3V	M15	USB0 charger enable (active high).
88	USB0_DRVVBUS	IO 3.3V	F16	USB0 VBUS control output (active high).
89	MDIO_CLK	IO 3.3V	M18	Multifunction pin.
90	MDIO_DATA	IO 3.3V	M17	Multifunction pin.

92	GMII1_RXCLK	IO 3.3V	L18	Multifunction pin.
93	GMII1_RXD0	IO 3.3V	M16	Multifunction pin.
94	GMII1_RXD1	IO 3.3V	L15	Multifunction pin.
95	GMII1_RXD2	IO 3.3V	L16	Multifunction pin.
96	GMII1_RXD3	IO 3.3V	L17	Multifunction pin.
98	GMII1_TXCLK	IO 3.3V	K18	Multifunction pin.
99	GMII1_TXD0	IO 3.3V	K17	Multifunction pin.
100	GMII1_TXD1	IO 3.3V	K16	Multifunction pin.
101	GMII1_TXD2	IO 3.3V	K15	Multifunction pin.
102	GMII1_TXD3	IO 3.3V	J18	Multifunction pin.
103	GMII1_RXDV	IO 3.3V	J17	Multifunction pin.
104	GMII1_RXERR	IO 3.3V	J15	Multifunction pin.
105	GMII1_TXEN	IO 3.3V	J16	Multifunction pin.
106	GMII1_CRS	IO 3.3V	H17	Multifunction pin.
107	GMII1_COL	IO 3.3V	H16	Multifunction pin.
108	RMII1_REFCLK	IO 3.3V	H18	Multifunction pin.
110	ADC_IN6	Input 1.8V	A8	ADC channel 6 analog input.
111	ADC_IN5	Input 1.8V	B8	ADC channel 5 analog input.
112	ADC_IN4	Input 1.8V	C8	ADC channel 4 analog input.
113	1.8V_ADC	Power Output	B9	+1.8V ADC reference voltage output.
114	ADC_IN3	Input 1.8V	A7	ADC channel 3 analog input.
115	ADC_IN2	Input 1.8V	B7	ADC channel 2 analog input.
116	ADC_IN1	Input 1.8V	C7	ADC channel 1 analog input.
117	ADC_IN0	Input 1.8V	B6	ADC channel 0 analog input.
119	MMC0_DAT1	IO 3.3V	G15	Multifunction pin.
120	MMC0_DAT0	IO 3.3V	G16	Multifunction pin.
122	MMC0_CLK	IO 3.3V	G17	Multifunction pin.
123	MMC0_CMD	IO 3.3V	G18	Multifunction pin.
124	MMC0_DAT3	IO 3.3V	F17	Multifunction pin.
125	MMC0_DAT2	IO 3.3V	F18	Multifunction pin.

126	UART0_RXD	IO 3.3V	E15	Multifunction pin.
127	UART0_TXD	IO 3.3V	E16	Multifunction pin.
128	UART0_CTS	IO 3.3V	E18	Multifunction pin.
129	UART0_RTS	IO 3.3V	E17	Multifunction pin.
131	UART1_RXD	IO 3.3V	D16	Multifunction pin.
132	UART1_TXD	IO 3.3V	D15	Multifunction pin.
133	UART1_CTS	IO 3.3V	D18	Multifunction pin.
134	UART1_RTS	IO 3.3V	D17	Multifunction pin.
136	ECAP0_IN_PWM0_OUT	IO 3.3V	C18	Multifunction pin.
137	I2C0_SDA(3)	IO 3.3V	C17	I2C0 data, connected to TPS65217C PMIC.
138	I2C0_SCL(3)	IO 3.3V	C16	I2C0 clock, connected to TPS65217C PMIC.
139	SPI0_D0	IO 3.3V	B17	Multifunction pin.
140	SPI0_D1	IO 3.3V	B16	Multifunction pin.
141	SPI0_CS0	IO 3.3V	A16	Multifunction pin.
142	SPI0_CS1	IO 3.3V	C15	Multifunction pin.
144	SPI0_SCLK	IO 3.3V	A17	Multifunction pin.
145	XDMA_EVENT_INTR0	IO 3.3V	A15	Multifunction pin.
146	XDMA_EVENT_INTR1	IO 3.3V	D14	Multifunction pin.
148	MCASP0_AHCLKX	IO 3.3V	A14	Multifunction pin.
149	MCASP0_ACLKX	IO 3.3V	A13	Multifunction pin.
150	MCASP0_FSX	IO 3.3V	B13	Multifunction pin.
151	MCASP0_AXR1	IO 3.3V	D13	Multifunction pin.
152	MCASP0_AXR0	IO 3.3V	D12	Multifunction pin.
153	MCASP0_FSR	IO 3.3V	C13	Multifunction pin.
154	MCASP0_ACLKR	IO 3.3V	B12	Multifunction pin.
155	MCASP0_AHCLKR	IO 3.3V	C12	Multifunction pin.
157	JTAG_TRST	Input 3.3V	B10	JTAG test reset (active low). This pin has internal 10k pull-down.
158	JTAG_TCK	Input 3.3V	A12	JTAG test clock input.
159	JTAG_TDO	Output 3.3V	A11	JTAG test data output.
160	JTAG_TDI	Input 3.3V	B11	JTAG test data input.

161	JTAG_TMS	Input 3.3V	C11	JTAG test mode select.
162	JTAG_EMU1	IO 3.3V	B14	Multifunction pin.
163	JTAG_EMU0	IO 3.3V	C14	Multifunction pin.
165	LED_ISET2	Input		Low-level LED backlight current set. See TPS65217C datasheet for details. If LED boost converter is not used leave unconnected.
166	LED_ISET1	Input		High-level LED backlight current set. See TPS65217C datasheet for details. If LED boost converter is not used leave unconnected.
167	LED_SINK2	Input		Input to the LED current SINK2. See TPS65217C datasheet for details. If LED boost converter is not used leave unconnected.
168	LED_SINK1	Input		Input to the LED current SINK1. See TPS65217C datasheet for details. If LED boost converter is not used leave unconnected.
169	LED_FB	Input		Feedback pin for LED boost converter. See TPS65217C datasheet for details. If LED boost converter is not used leave unconnected.
170, 171	LED_L	Output		Switch pin of LED boost converter. Connect to inductor. See TPS65217C datasheet for details. If LED boost converter is not used leave unconnected.
172, 173	V_SYS	Power Output		System voltage output of the power path. See TPS65217C datasheet for details.
176, 177	3.3VD(4)	Power Output		+3.3V LDO4 output from TPS65217C.
178	3.3VA	Power Output		+3.3V LDO2 output from TPS65217C.
181, 182	V_BAT	Power Input		Battery power input and charger output. Connect to single cell Li+ battery.
183	BAT_SENSE	Input		Battery voltage sense input, connect to V_BAT directly at the battery terminal.
184	BAT_TEMP	Input		Temperature sense input. Connect to NTC thermistor to sense battery temperature. Works with 10k and 100k thermistors. If charger is not used connect by 10k resistor to ground.

(1) LCD_DATA[15:0] terminals are respectively SYSBOOT[15:0] inputs, latched on power-up. External 10k-47k pull-up/pull-down resistors are needed on this terminals for proper boot configuration.

(2) This terminal is internally connected to NAND Flash memory and it's use is limited to GPMC functionality.

(3) This terminal is connected to PMIC and it's use is limited to I2C0 peripheral. It has internal 4.7k pull-up resistor to 3.3V. It should be checked if there is no I2C address conflict with PMIC.

(4) LDO4 is also powering AM335X IO buffers, USB PHY and NAND Flash, so maximum current output is reduced.

3.2. Boot Configuration Pins

During boot process AM335x processor senses SYSBOOT[15:0] configuration pins (see LCD_DATA[15:0] pin description). It's state is latched on power-up, so every SYSBOOT[15:0] pin should have external pull-up/pull-down resistor connected. For pull-up voltage use 3.3VD output. The chiliSOM uses 24MHz crystal oscillator so SYSBOOT[15:14] is always 01b for all boot modes. For complete SYSBOOT[15:0] configuration pins description refer to section 26.1.5.2.1 in AM335x Technical Reference Manual.

4. Electrical Characteristics

4.1. Absolute Maximum Ratings

	min.	max.	unit
Supply voltage, V_DC, V_USB	-0.3	20	V
Supply voltage, V_BAT	-0.3	7	V
Terminal current, V_SYS, V_USB, V_BAT		3	A
Operating ambienttemperature (commercial)	0	70	°C
Operating ambienttemperature (industrial)	-20	85	°C

Stresses beyond those listed under Absolute Maximum Ratings may cause permanent damage to the module. These are stress ratings only, and functional operation of the device at these or any other conditions beyond those indicated under Recommended Operating Conditions is not implied. Exposure to absolute maximum rated conditions for extended periods may affect module reliability. For detailed absolute maximum ratings see AM335X and TPS65217C datasheet.

4.2. Recommended Operating Conditions

	min.	Nom.	max.	unit
Supply voltage, V_DC, V_USB	4.3	5.0	5.8	V
Supply voltage, V_BAT	2.7	3.6	5.5	V
Battery current, V_BAT			2	A
Outputcurrent, 3.3VA	0		100	mA
Outputcurrent, 3.3VD(1)	0		400 (200)	mA
Outputcurrent, 1.8V_ADC	0		50	mA

(1) Output current from 3.3VD is reduced by current consumption of AM335X USB PHY, IO Buffers and NAND Flash memory. Maximum current consumption of 2 x USB PHY and NAND memory is 40+40+35=115mA. Current consumption of IO Buffers is dependent on application. It's recommended to use maximum of 200mA from 3.3VD output. For detailed recommended operating conditions see AM335X and TPS65217C datasheet.

5. Mechanical Characteristics

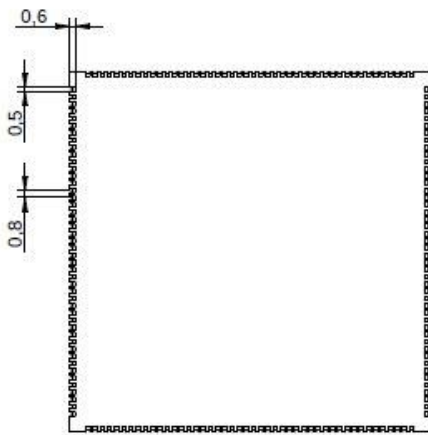
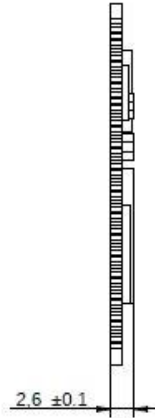
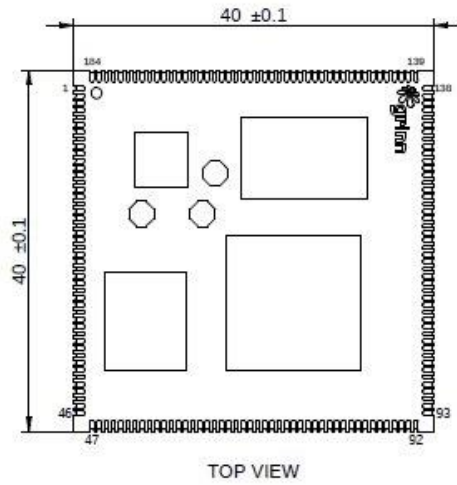

BOTTOM VIEW

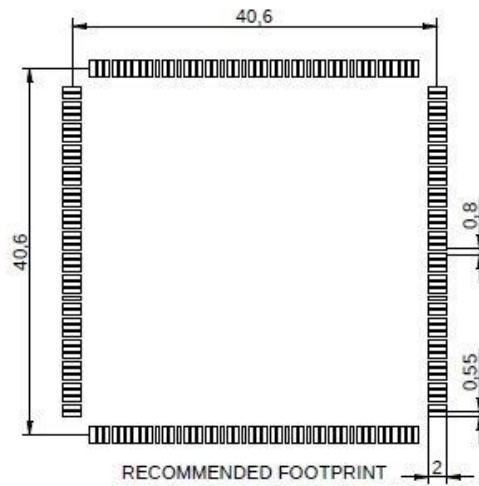

RECOMMENDED FOOTPRINT

6. Ordering Information

6.1. Nomenclature

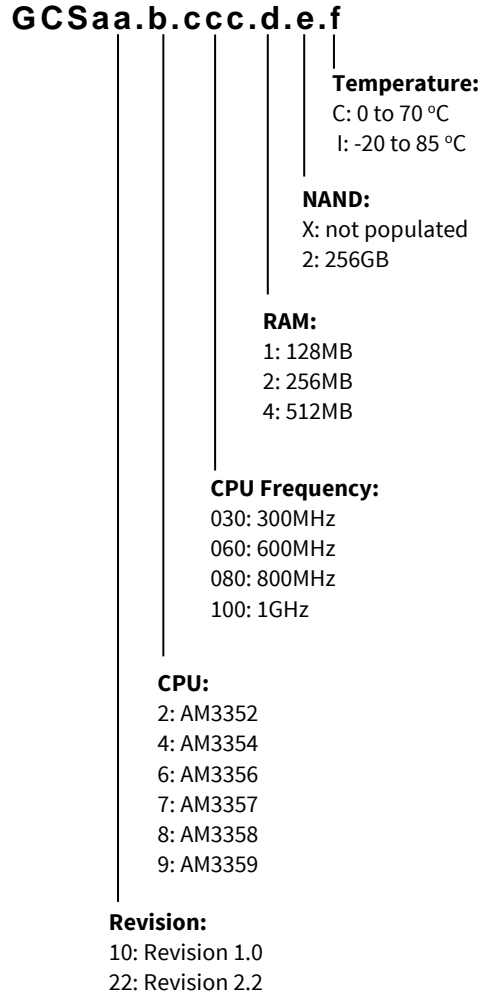

6.2. Order table

Order No	Processor	3D Graphic Engine	RAM	NAND	Temperature
GCS22.2.060.1.2.C	AM3352 600MHz	no	128MB	256MB	0 to 70°C
GCS22.2.060.1.2.I*	AM3352 600MHz	no	128MB	256MB	-20 to 85°C
GCS22.2.080.1.2.C*	AM3352 800MHz	no	128MB	256MB	0 to 70°C
GCS22.2.080.1.2.I	AM3352 800MHz	no	128MB	256MB	-20 to 85°C

GCS22.2.080.2.2.C*	AM3352 800MHz	no	256MB	256MB	0 to 70°C
GCS22.2.080.2.2.I*	AM3352 800MHz	no	256MB	256MB	-20 to 85°C
GCS22.4.100.4.2.C	AM3354 1000MHz	yes	512MB	256MB	0 to 70°C

*minimum order quantity 1000 pcs

For other configurations please contact with distributor.

7. Reference Documentation

SPRS717F Sitara AM335x ARM Cortex-A8 Microprocessors (MPUs)

SPRZ360F Sitara AM335x ARM Cortex-A8 Microprocessors Silicon Errata (Revs 2.1, 2.0, 1.0)

SPRUH73J AM335x ARM Cortex-A8 Microprocessors (MPUs) Technical Reference Manual (Rev. J)

SLVSB64F Single-Chip PMIC for Battery-Powered Systems (Rev. F)

8. Document Revision History

Document Revision	Notes
1.2	Corrected document layout, corrected nomenclature diagram, added chiliSOM photo.
1.1	Corrected description of GPMC_WP pin – this pin is not internally connected to NAND Flash Memory on module.
1.0	Initial revision.

Grinn Sp. z o.o.

POLAND

ul. Wagonowa 2

53-609 Wrocław

t. +48 71 716 40 99

m. office@grinn-global.com

www.grinn-global.com

© Copyright 2016 Grinn

All rights reserved. No part of this document may be photocopied or recorded on any electronic media without written permission of Grinn. The information contained in this documentation is subject to change without prior notice. We assume no liability for erroneous information or its consequences. Grinn reserves the right to change details in this publication without notice. Grinn makes no representations or warranties with respect to the accuracy or completeness of the contents of this document and reserves the right to make changes to specifications and products descriptions at any time without notice. Grinn does not make any commitment to update the information contained herein. Trademarks used from other companies refer exclusively to the products of those companies. Product and company names herein may be the trademarks of their respective owners.

X-ON Electronics

Largest Supplier of Electrical and Electronic Components

Click to view similar products for [Single Board Computers](#) category:

Click to view products by [GRINN](#) manufacturer:

Other Similar products are found below :

[MANO882VPGGA-H81](#) [SSD3200W-S-SLC-INN](#) [AmITX-SL-G-Q170](#) [IB100](#) [MVME61006E-2173R](#) [DBS2600CWT](#) [HNS2600JF](#) [20-101-0738](#) [PCE-4128G2-00A1E](#) [RSB-4220CS-MCA1E](#) [SHB230DGGA-RC](#) [IB909AF-5650](#) [AmITX-BT-I-E3815](#) [PICO841VGA-E3827](#) [IMB210VGGA](#) [MI981AF](#) [RSB-4221CS-MCA1E](#) [PCE-9228G2I-00A1E](#) [AIMB-275G2-00A1E](#) [IB915F-3955](#) [IB909F-5010](#) [MI958F-16C](#) [Nitrogen7](#) [UPS-P-8G-64GB-PACK](#) [S2600WFT](#) [IB915AF-6300](#) [S2600STB](#) [BBS2600BPS](#) [IB915F-6100](#) [Nit6QP_MAX](#) [MI990VF-X28-E](#) [MI990VF-6820](#) [MI991AF-C236](#) [94AC6636](#) [BANANA PI BPI-M4](#) [BLKNUC7I3DNHNC1978015](#) [BLKNUC7I5DNK1E 960791](#) [IOT-LS1012A-OXALIS](#) [NITX-300-ET-DVI](#) [94AC6633](#) [CS-OMEGA-08](#) [RX0210](#) [RX0213](#) [RX0216](#) [CASE SLIDE WHITE](#) [CASE SLIDE CLEAR](#) [MICROSOM I2 + WIFI/BT](#) [HUMMINGBOARD-I1 PRO + WIFI/BT](#) [HUMMINGBOARD-I2EX BASE + WIFI/BT](#) [HUMMINGBOARD-I2 PRO](#)