

FANS

THE DOMUS PLEDGE OF SAFETY AND QUALITY

Domus fans are tested to the strictest levels of quality and safety providing one of the safest fans on the market.

- BSI Kitemarked to BS EN 60335 for electrical safety*
- Tested by BSRIA for airflow performance to ISO 5801
- Sound tested by SRL to ISO 3741:1988 (reports available)
- Fans exceed the requirements of the Building Regulations
- Fans are made from tough fire retardant UV stabilised materials
- Fans are easily cleaned, maintained and installed
- Splash-proof rated
- Domus is a member of a BS EN ISO 9002 registered group
- Easy to follow and comprehensive instructions
- Robust packaging protects the fans



* Except T1C, T1EC, P1C and ELF Models

PRODUCT CODES/PACKAGING TYPE

The product codes throughout this catalogue are shown as either a Boxed or Prepacked option. This refers to the type of packaging that the product will be supplied in.



Boxed



Prepacked

ICONS

To assist in fan selection, icons are used throughout this catalogue. These are used to indicate the room that the fan can be used in and the model type.

ROOM LOCATIONS



toilet



shower



bathroom



kitchen



utility room



whole house

MODEL OPTIONS



standard

Switch fan on/off manually by remote switch e.g. light switch/dedicated switch.



pull switch

Switch fan on/off manually using integral pull switch.



timer

Fan switches on using a remote switch (light) and includes an adjustable overrun timer (1 to 25 mins) so that the fan continues to remove excess moisture and odours after switching off the fan.



movement detector

Sensitive to movement coupled with heat preventing accidental tripping. Switches on when body movement is detected. Also includes timer function.



humidistat

Switches on/off automatically once a preset level of humidity is reached. Integral condensation control is adjustable between 60 and 80% RH @ 21 °C, which enables the fan to continuously monitor humidity. Also includes timer function.



humidistat/pull switch

Specification as humidistat version but with the additional of a pull switch for manual override.



auto shutter

Shutters open during operation and close when not in use to prevent back drafts. Available with timer or pull switch and as a standard model. Operated by a silent thermoactuator.



SELV

12V fan or light unit.

DOMUS 100MM AXIAL FANS



- Exceeds Building Regulations for bathrooms and toilets
- Window or wall fixing options
- BSI Kitemarked to BS EN 60335 for electrical safety
- IPx4 Splash-proof rating
- Tough white high gloss ABS (fire retardant and UV stabilised)
- Multiple model options
- Stainless steel ball bearing versions
- Quick and easy installation
- Three year guarantee

The DOMUS 100mm axial fan is a stylish unit made from safe, durable, easily cleaned high gloss ABS. Suitable for wall or window installation.

Model options include: Standard, Pull-cord Switch, Timer, Humidistat (with or without Pull-cord Switch), Movement Detector, Auto Shutter and SELV 12V enabling the range to meet most installation requirements. Some

models are also available with a stainless steel ball bearing motor providing greater efficiency, lower noise and longer life.

The SELV 12V fan used in conjunction with a Domus transformer (see page 74) is suitable for safety critical domestic environments and can, therefore, be safely installed within zone 1 near a bath or shower, as stated in amendment 3 of BS7671:1992. The

transformer must be mounted away from the source of water spray and out of the safety critical area.

The 100mm range exceeds the Building Regulation requirement of 15 l/s for bathrooms.



Passive Infra-red Movement Detector fans incorporate the world's smallest passive infra red sensor fitted to a domestic fan



MOVEMENT DETECTION RANGE

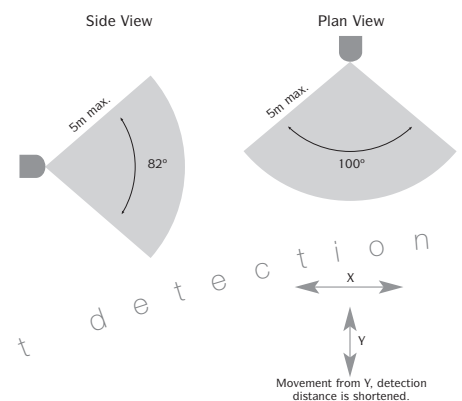

DOMUS 100MM AXIAL FANS



Product Code		Description	Extract performance			Power W	dB(A) @ 3m	Weight kg	Model
Boxed	Prepack		l/s	m ³ /hr	cfm				
Standard Fans									
S1	S1R	Wall Fan	26	94	55	15	38.8	0.6	
SB1	n/a	Wall Fan with Ball Bearing Motor	26	94	55	15	38.8	0.6	
S1W	S1WR	Window Fan	18	65	38	15	38.8	0.6	
S1K	S1KR	Wall Fan & Wall Fixing Kit	24	86	50	15	38.8	0.6	
Pull Switch Fans									
P1	P1R	Wall Fan	26	94	55	15	38.8	0.6	
PB1	n/a	Wall Fan with Ball Bearing Motor	26	94	55	15	38.8	0.6	
P1W	P1WR	Window Fan	18	65	38	15	38.8	0.6	
P1K	P1KR	Wall Fan & Wall Fixing Kit	24	86	50	15	38.8	0.6	
Timer Fans									
T1	T1R	Wall Fan	26	94	55	15	38.8	0.6	
TB1	n/a	Wall Fan with Ball Bearing Motor	26	94	55	15	38.8	0.6	
T1W	T1WR	Window Fan	18	65	38	15	38.8	0.6	
T1K	T1KR	Wall Fan & Wall Fixing Kit	24	86	50	15	38.8	0.6	
Movement Detector Fans									
M1	n/a	Wall Fan	26	94	55	15	38.8	0.6	
MB1	n/a	Wall Fan with Ball Bearing Motor	26	94	55	15	38.8	0.6	
Humidistat Fans									
H1	H1R	Wall Fan	26	94	55	15	38.8	0.6	
H1W	H1WR	Window Fan	18	65	38	15	38.8	0.6	
H1K	H1KR	Wall Fan & Wall Fixing Kit	24	86	50	15	38.8	0.6	
Humidistat/Pull Switch Fans									
HP1	HP1R	Wall Fan	26	94	55	15	38.8	0.6	
HP1W	HP1WR	Window Fan	18	65	38	15	38.8	0.6	
HP1K	HP1KR	Wall Fan & Wall Fixing Kit	24	86	50	15	38.8	0.6	
Auto Shutter Fans									
AS1	n/a	Standard Wall Fan	26	94	55	21	38.8	0.7	
AP1	n/a	Pull Switch Wall Fan	26	94	55	21	38.8	0.7	
AT1	n/a	Timer Wall Fan	26	94	55	21	38.8	0.7	

DOMUS 100MM AXIAL FANS



Product Code		Description	Extract performance			Power W	dB(A) @ 3m	Weight kg	Model	
Boxed	Prepack		l/s	m ³ /hr	cfm					
SL1	n/a	SELV 12 Volt Fans Wall Fan <small>Requires 12V transformer (see page 74)</small>	26	94	55	15	38.8	0.6		
n/a	SL1VKR	Wall Fan and Fixing Kit with Standard Transformer	24	86	50	15	38.8	0.6		
n/a	PL1VKR	Wall Fan and Fixing Kit with Pull Switch Transformer	24	86	50	15	38.8	0.6		
n/a	TL1VKR	Wall Fan and Fixing Kit with Timer Transformer	24	86	50	15	38.8	0.6		
n/a	HL1VKR	Wall Fan and Fixing Kit with Humidistat Transformer	24	86	50	15	38.8	0.6		
n/a	HPL1VKR	Wall Fan and Fixing Kit with Humidistat/Pull Switch Transformer	24	86	50	15	38.8	0.6		

All wall fixing kits come supplied with 400mm of compressed aluminium duct and brown external louvred outlet (and flaps for conversion to gravity flap outlet).

ACCESSORIES

Product Code		Description	Fitting size	Extract performance*			Specification
Boxed	Prepack			l/s	m ³ /hr	cfm	
1K	1KR	100mm Fixing Kits Wall Fixing Kit for 100mm axial fans	100-400mm	24	86	50	Contains 400mm of compressed aluminium duct and brown external louvred outlet (and flaps for conversion to gravity flap outlet). Contains window gravity flap outlet, seal and fixings.
1W	1WR	Window Fixing Kit for 100mm axial fans	3-22mm	18	65	38	

Boxed	Prepack	Description	Connects to	Fascia Dimensions	Specification
n/a	F1CHR	100mm Interchangeable Fascias Chrome Fascia	100mm axial fans	141 x 141mm	For installation with all 100mm axial fans except HP (Humidistat with Pull Switch), M (Movement Detector) and A (Auto Shutter) models.
n/a	F1ALR	Brushed Aluminium Fascia	100mm axial fans	141 x 141mm	
n/a	F1GDR	Gold Fascia	100mm axial fans	141 x 141mm	

*When installed with the appropriate Domus fan

DOMUS 100MM AXIAL FANS

DIMENSIONS

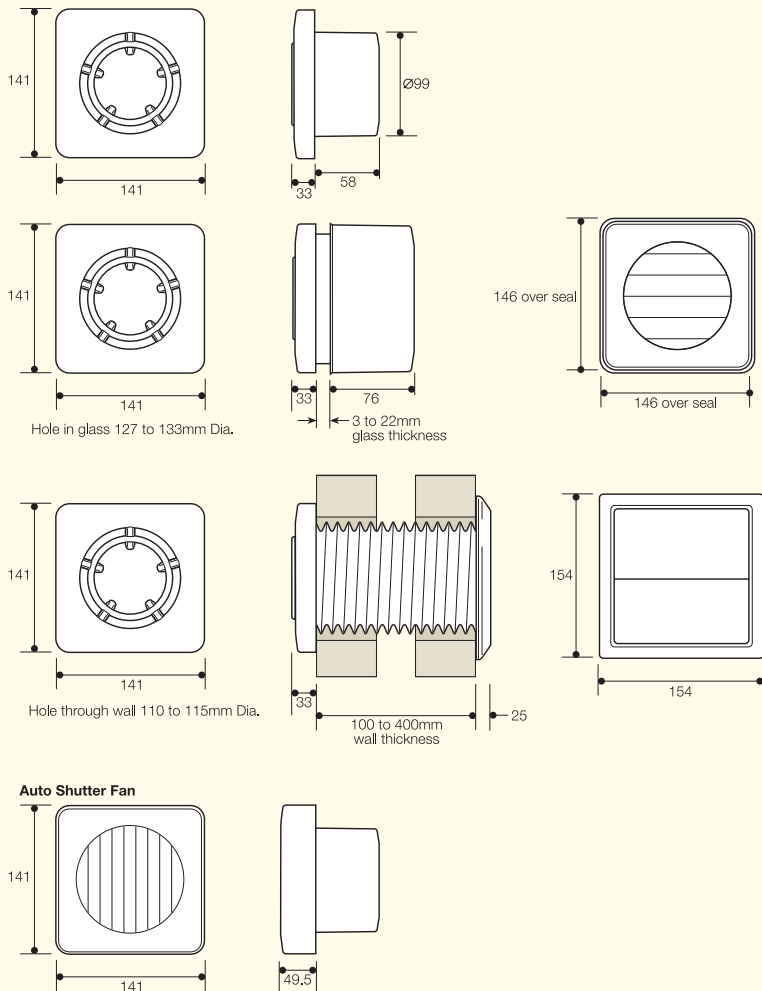

AXIAL FANS

Axial fans are designed for air movement over short distances as the air enters and leaves the impellers parallel with the fan axis. As a result, typical installations would be through a wall or a window. Domus axial fans should only be used for short duct runs up to a maximum of 1.5m.

PERFORMANCE GRAPH

Tested to ISO 5801:1997 (TYPE A).
BSRIA Report Number 14404/1 03/99.

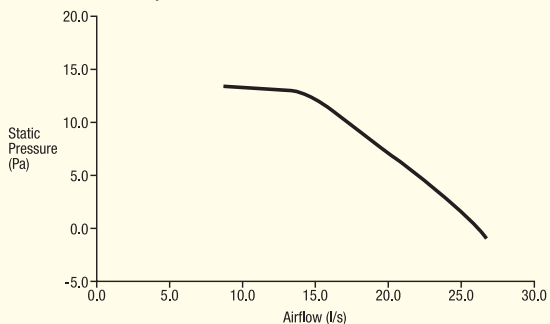

ELECTRICAL SPECIFICATIONS

220-240 V ~ 50Hz (SELV versions 12 V ~ 50Hz)

Insulation class II / Double insulated

Splash-proof (equivalent IPx4)

Motors fitted with standard thermal fuses

(SELV versions motor fitted with auto-reset thermal cutouts)

Wiring must comply with latest IEE Wiring Regulations (BS7671)

DOMUS 100MM AXIAL DISCFANS



- Exceeds Building Regulations for bathrooms and toilets
- Wall fixing option
- BSI Kitemarked to BS EN 60335 for electrical safety
- IPx4 Splash-proof rating
- Tough white high gloss ABS (fire retardant and UV stabilised)
- Three model options
- Ultra slim, stylish round design
- Quick and easy installation
- Three year guarantee



The smooth round design and ultra slim profile (only 7mm) of the Domus axial DiscFan offers a compact and unobtrusive solution when style is as important as performance.

The fan is designed with a removable front fascia disc and nose cone to provide easy maintenance and cleaning. The simple 'clip on/off' features also allow the user to 'select-a-disc' to suit their mood or the ambience of the room.

DiscFan is available in three model options: standard, timer and humidistat, which meet most installation requirements. The fans have a high specification motor designed for

durability and exceed the Building Regulation requirement of 15 l/s for domestic bathrooms to facilitate the removal of moisture and condensation, caused by inadequate ventilation.

DiscFan is recommended for effective ventilation of rooms when installed through an outside wall or when the distance to the termination point is under 1.5m.

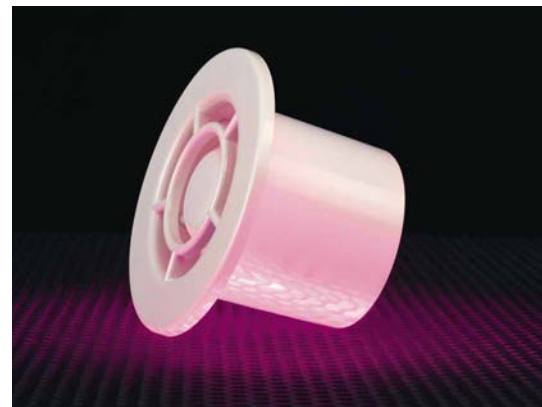

DIMENSIONS

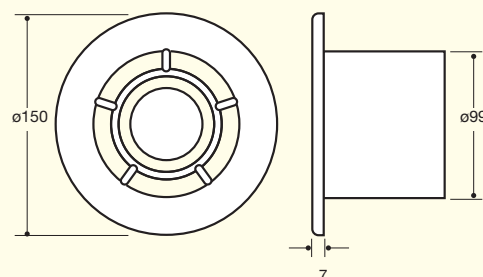

All measurements in mm. Drawings not to scale.

DOMUS 100MM AXIAL DISCFANS



Product Code		Description	Extract performance			Power W	dB(A) @ 3m	Weight kg	Model
Boxed	Prepack		l/s	m ³ /hr	cfm				
DS1	DS1R	Standard DiscFan Wall Fan	22	77	55	15	38.8	0.5	
DT1	DT1R	Timer DiscFan Wall Fan	22	77	55	15	38.8	0.5	
DH1	DH1R	Humidistat DiscFan Wall Fan	22	77	55	15	38.8	0.5	

ACCESSORIES

Product Code		Description	Fitting size	Extract performance*			Specification
Boxed	Prepack			l/s	m ³ /hr	cfm	
1K	1KR	100mm Fixing Kits Wall Fixing Kit for DiscFans	100-400mm	22	77	55	Contains 400mm of compressed aluminium duct and brown external louvred outlet (and flaps for conversion to gravity flap outlet).

Boxed	Prepack	Description	Connects to	Fascia Dimensions	Specification
n/a	DF1CHR	DiscFan Interchangeable Fascias Chrome Fascia	100mm DiscFans	Outer rim 150mm	For installation with all 100mm axial DiscFans.
n/a	DF1ALR	DiscFan Interchangeable Fascias Brushed Aluminium Fascia	100mm DiscFans	Outer rim 150mm	
n/a	DF1GDR	DiscFan Interchangeable Fascias Gold Fascia	100mm DiscFans	Outer rim 150mm	

*When installed with the appropriate Domus fan.
Please note that the DiscFan is not suitable for window installations.



ELECTRICAL SPECIFICATIONS

220-240 V ~ 50Hz

Insulation class II / Double insulated

Splash-proof (equivalent IPx4)

Motors fitted with standard thermal fuses

Wiring must comply with latest IEE Wiring Regulations (BS7671)

PERFORMANCE GRAPH

Tested to ISO 5801:1997 (Type A).
BSRIA Report Number 16060/1 02/01.

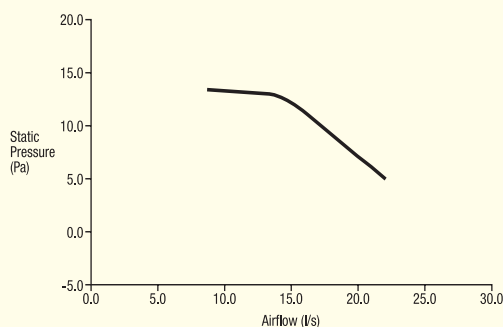

DOMUS 100MM CENTRIFUGAL FANS



- Exceeds Building Regulations for bathrooms and toilets. P1C/T1C also exceeds regulations for utility rooms
- Suitable for wall or ceiling installation
- For long ducting runs
- Integral back draft flap
- IPx4 Splash-proof rating
- Tough white high gloss ABS (fire retardant and UV stabilised)
- Quick and easy installation
- Three year guarantee

The DOMUS 100mm centrifugal fans are versatile and powerful units made from safe, durable, easily cleaned high gloss ABS. Suitable for wall or ceiling installation.

Model options include: Pull-cord Switch and Timer. The economy version is only available as a timer version.

The 100mm range exceeds the Building Regulation requirement of 30 l/s for utility rooms, although the economy version only exceeds the requirement of 15 l/s for bathrooms.



A centrifugal fan recess mounted (T1C).



Economy centrifugal fan (T1EC).

CENTRIFUGAL FANS

Centrifugal fans are designed for air movement over long distances as the air enters the impeller in an axial direction and leaves it in a radial direction. This creates high pressure enabling air to travel quicker and further. Domus centrifugal fans can be used for long duct runs of between 10-15m.

DOMUS 100MM CENTRIFUGAL FANS



P1C/T1C
only

Product Code	Description	Extract performance			Power W	dB(A) @ 3m	Weight kg	Model		
		Boxed	Prepack	I/s					m ³ /hr	cfm
P1C	Pull Switch Fan Wall / Ceiling Fan	n/a		31	111	65	30	55	1.5	
T1C	Timer Fan Wall / Ceiling Fan	n/a		31	111	65	30	55	1.5	
T1EC	Economy Timer Fan Wall / Ceiling Fan	n/a		27	98	57	30	41	0.8	

ACCESSORIES

Boxed	Prepack	Description	Fitting size	Specification
2CB	n/a	100mm Centrifugal Fan Boxes Fan box for P1C/T1C to PolyVent 225	To fit 234 x 29mm ducting	Connects surface mounted centrifugal fans (P1C/T1C ONLY) to Domus PolyVent 225 ducting without the need for additional adapters. Helps to provide optimum airflow conditions.
3CB	n/a	Fan box for P1C/T1C to PolyVent 300	To fit 308 x 29mm ducting	Connects surface mounted centrifugal fans (P1C/T1C ONLY) to Domus PolyVent 300 ducting without the need for additional adapters. Helps to provide optimum airflow conditions.

DIMENSIONS

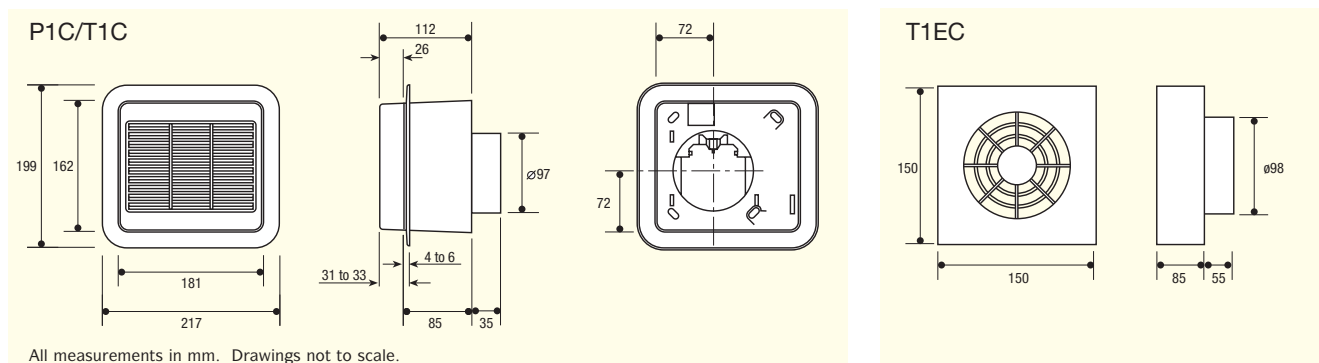

PERFORMANCE GRAPH

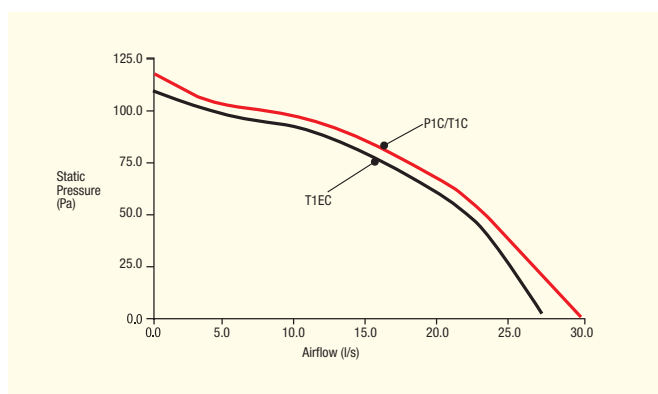

ELECTRICAL SPECIFICATIONS

220-240 V ~ 50Hz

Insulation class II / Double insulated

Splash-proof (equivalent IPx4)

Motors fitted with standard thermal fuses

Wiring must comply with latest IEE Wiring Regulations (BS7671)

DOMUS 100MM IN-LINE DUCT FANS



- Exceeds Building Regulations for bathrooms and toilets
- Ideal for installation within shower cubicles
- BSI Kitemarked to BS EN 60335 for electrical safety
- Tough white high gloss ABS (fire retardant and UV stabilised)
- Two model options
- Stainless steel ball bearing versions
- Quick and easy installation
- Kits including two grilles and 3m of flexible ducting can be supplied
- VentLight kit available
- Three year guarantee

The DOMUS 100mm mixed flow in-line duct fan has been designed to provide a high extract rate over long distances where a high rate of extraction is a prerequisite.

The unit is produced in clean white ABS with detachable mounting foot to allow fast trouble free installation.

Model options include: Standard and Timer. Models are also available with a stainless steel ball bearing motor providing greater efficiency, lower noise and longer life.

Available as a prepacked kit including inlet and outlet grilles and 3m of flexible PVC ducting.

The 100mm range exceeds the Building Regulations requirement of 15 l/s for bathrooms.

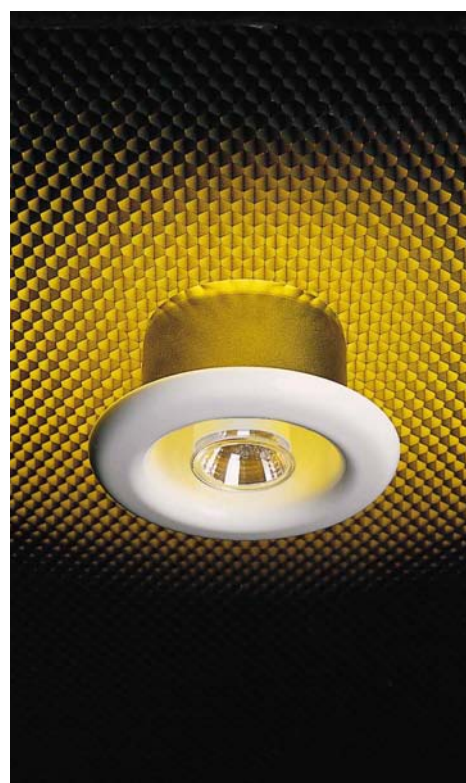

The stylish Domus VentLight incorporates a low voltage light and air vent. Ideal for shower cubicles.

DOMUS 100MM IN-LINE DUCT FANS



Product Code		Description	Extract performance			Power W	dB(A) @ 3m	Weight kg	Model	Light
Boxed	Prepack		l/s	m ³ /hr	cfm					
S1D	n/a	Standard Duct Fans Duct Fan	17	58	36	15	-	0.5		
SB1D	n/a	Duct Fan with Ball Bearing Motor	17	58	36	15	-	0.5		
S1DK	S1DKR	Duct Fan & Ceiling Kit	-	-	-	15	-	0.5		
LS1DK	LS1DKR	Standard VentLight Kits Duct Fan & VentLight Ceiling Kit - White	-	-	-	15	-	0.5		
LS1DKCH	LS1DKCHR	Duct Fan & VentLight Ceiling Kit - Chrome	-	-	-	15	-	0.5		
LS1DKGD	LS1DKGDR	Duct Fan & VentLight Ceiling Kit - Gold	-	-	-	15	-	0.5		
LS1DKAL	LS1DKALR	Duct Fan & VentLight Ceiling Kit - Brushed Aluminium	-	-	-	15	-	0.5		
T1D	n/a	Timer Duct Fans Duct Fan	17	58	36	15	-	0.5		
TB1D	n/a	Duct Fan with Ball Bearing Motor	17	58	36	15	-	0.5		
T1DK	T1DKR	Duct Fan & Ceiling Kit	-	-	-	15	-	0.5		
LT1DK	LT1DKR	Timer VentLight Kits Duct Fan & VentLight Ceiling Kit - White	-	-	-	15	-	0.5		
LT1DKCH	LT1DKCHR	Duct Fan & VentLight Ceiling Kit - Chrome	-	-	-	15	-	0.5		
LT1DKGD	LT1DKGDR	Duct Fan & VentLight Ceiling Kit - Gold	-	-	-	15	-	0.5		
LT1DKAL	LT1DKALR	Duct Fan & VentLight Ceiling Kit - Brushed Aluminium	-	-	-	15	-	0.5		

Ceiling kit performance figures cannot be given as they vary on the installation.

Ceiling kits are supplied with inlet, 3m of compressed PVC flexible duct, brown louvred outlet (and flaps for conversion to gravity flap outlet) and all necessary fixings.

VentLight contains 12V 35W halogen floodlight with cover lens. Kits include 12V 60W transformer.

ACCESSORIES

Boxed	Prepack	Description	Fitting size	External Dimensions	Specification
LV1	n/a	100mm VentLight inc. 12V Transformer White	100mm o.d.	Outer rim 150mm	12V 35W Halogen Floodlight with cover lens. Includes 12V 60W electronic transformer suitable for 12V Halogen lamps.
LV1CH	n/a	Chrome	100mm o.d.	Outer rim 150mm	
LV1AL	n/a	Brushed Aluminium	100mm o.d.	Outer rim 150mm	
LV1GD	n/a	Gold	100mm o.d.	Outer rim 150mm	

WARNING! VentLights must be installed in conjunction with an in-line duct fan

DOMUS 100MM IN-LINE DUCT FANS



DIMENSIONS

100mm In-line Fan

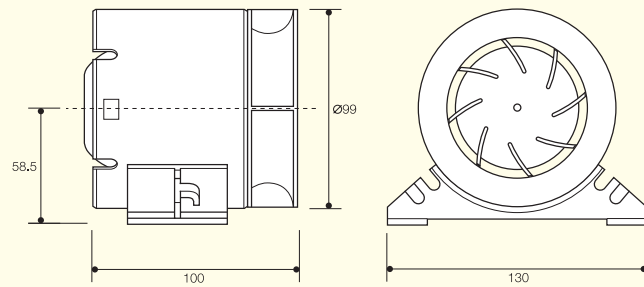

100mm VentLight

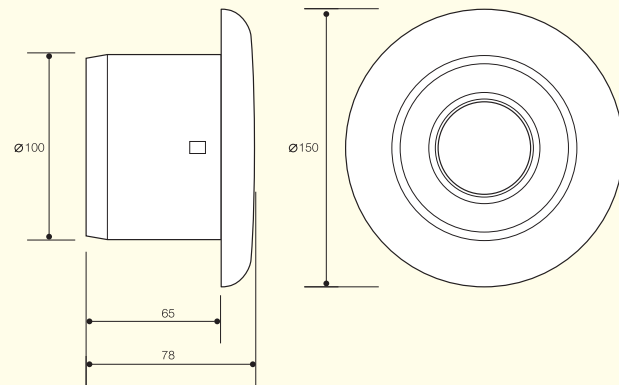

All measurements in mm. Drawings not to scale.

The DOMUS VentLight is a stylish SELV rated air inlet featuring an integral 12V halogen floodlight. It is ideal for safe installation in the bath/shower room and can be installed within the shower cubicle (zone 1). The VentLight can be supplied as a kit complete with transformer, in-line duct fan, flexible duct and external wall outlet. The VentLight is available in white, chrome, gold and aluminium.

The VentLight with 12V transformer is also available with its own without the fan and ceiling kit (see page 61).



In-line Duct Fan and Ceiling Kit comes with louvred outlet and optional gravity flaps.

DOMUS 100MM IN-LINE DUCT FANS

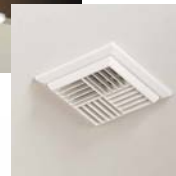
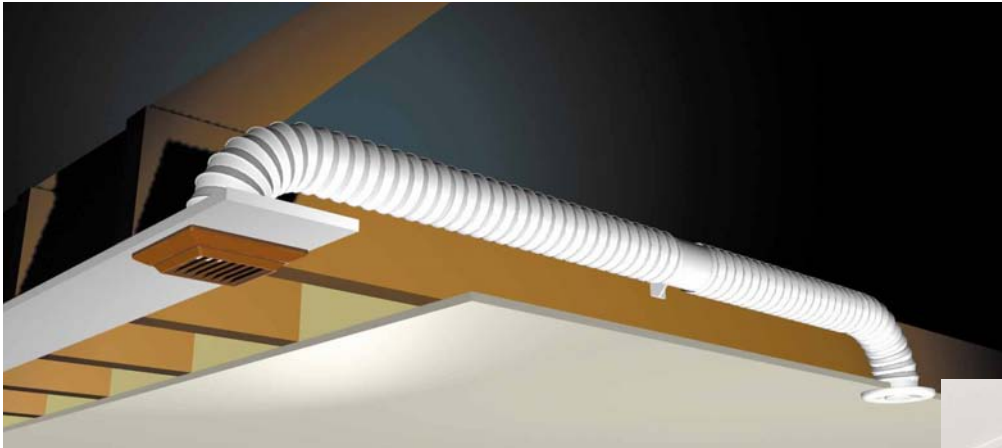

A typical installation of an in-line mixed flow fan. The mixed flow blade design enables effective extraction up to 4m. In-line fans are concealed in the loft or ceiling void.

A condensation trap is recommended if the ducting is installed vertically in an unheated roof void (Domus ref: 497 see Ducting section pages 13 and 27).



ELECTRICAL SPECIFICATIONS

220-240 V ~ 50Hz

Insulation class II / Double insulated

Drip-proof (equivalent IPx2)

Motors fitted with standard thermal fuses

Wiring must comply with latest IEE Wiring Regulations (BS7671)

VentLight 12V 35W Halogen flood light with covered lens - kits supplied with 60W transformer.

PERFORMANCE GRAPH

Tested to ISO 5801:1997 (Type A).
BSRIA Report Number 14404/1 03/99.

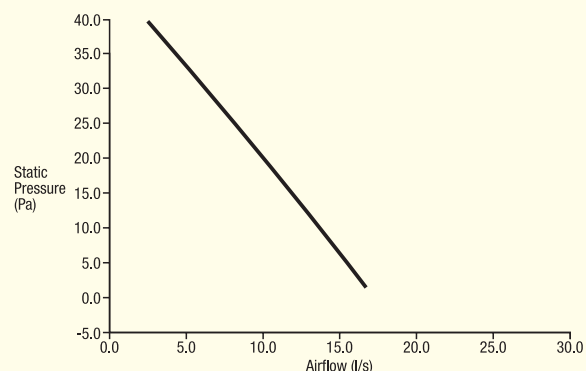

DOMUS 125MM AXIAL FANS



- Exceeds Building Regulations for utility rooms, bathrooms and toilets
- Suitable for window or wall installation
- Kitemarked to BS EN 60335 for electrical safety
- IPx4 Splash-proof rating
- Tough white high gloss ABS (fire retardant and UV stabilised)
- Multiple model options
- Quick and easy installation
- Stainless steel ball bearing versions
- Three year guarantee

The DOMUS 125mm axial fan is a stylish unit made from safe, durable, high gloss ABS. Suitable for wall or window installation.

Model options include: Standard, Pull-cord Switch, Timer, Humidistat (with or without Pull-cord Switch), Movement Detector and SELV 12V enabling the range to meet most installation requirements. Some models are also available with a stainless steel ball bearing motor providing greater efficiency, lower noise and longer life.

The SELV 12V fan, used in conjunction with a transformer (see page 74) is suitable for safety critical domestic environments and can, therefore, be safely installed within zone 1 near a bath or shower as stated in amendment 3 of BS 7671: 1992. The transformer must be mounted away from the safety critical area.

Exceeds the Building Regulation requirement of 30 l/s for utility rooms.

DIMENSIONS

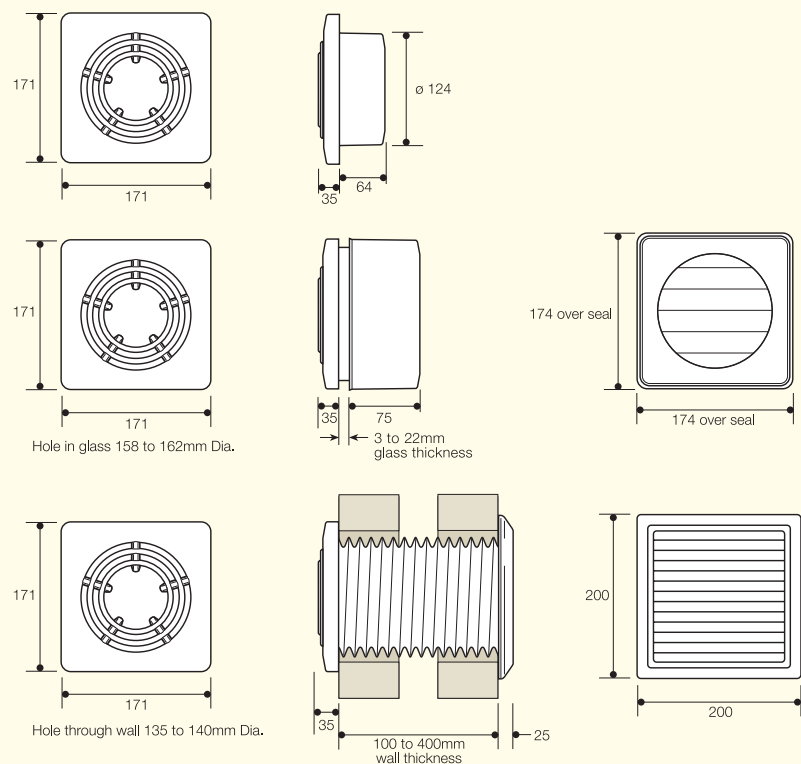

All measurements in mm. Drawings not to scale.

DOMUS 125MM AXIAL FANS



Product Code		Description	Extract performance			Power W	dB(A) @ 3m	Weight kg	Model
Boxed	Prepack		l/s	m ³ /hr	cfm				
S12 SB12	n/a	Standard Fans Wall Fan	49	176	103	25	47.1	0.8	
	n/a	Wall Fan with Ball Bearing Motor	49	176	103	25	47.1	0.8	
P12 PB12	n/a	Pull Switch Fans Wall Fan	49	176	103	25	47.1	0.8	
	n/a	Wall Fan with Ball Bearing Motor	49	176	103	25	47.1	0.8	
T12 TB12	n/a	Timer Fans Wall Fan	49	176	103	25	47.1	0.8	
	n/a	Wall Fan with Ball Bearing Motor	49	176	103	25	47.1	0.8	
M12 MB12	n/a	Movement Detector Fans Wall Fan	49	176	103	25	47.1	0.8	
	n/a	Wall Fan with Ball Bearing Motor	49	176	103	25	47.1	0.8	
H12	n/a	Humidistat Fan Wall Fan	49	176	103	25	47.1	0.8	
HP12	n/a	Humidistat/Pull Switch Fan Wall Fan	49	176	103	25	47.1	0.8	
SL12	n/a	 SELV 12V Fan Wall Fan Requires 12V transformer (see page 74)	49	176	103	25	47.1	0.8	

ACCESSORIES

Product Code		Description	Fitting size	Extract performance*			Specification
Boxed	Prepack			l/s	m ³ /hr	cfm	
12K	n/a	125mm Fixing Kits Wall Fixing Kit for 125mm axial fans	100-400mm	45	164	96	Contains 400mm of compressed aluminium duct and brown external louvred outlet. Contains window gravity flap outlet, seal and fixings.
12W	n/a	Window Fixing Kit for 125mm axial fans	3-22mm	39	140	82	

ELECTRICAL SPECIFICATIONS

220-240 V ~ 50Hz (SELV versions 12 V ~ 50Hz)

Insulation class II / Double insulated

Splash-proof (equivalent IPx4)

Motors fitted with standard thermal fuses (SELV versions motor fitted with auto-reset thermal cutouts)

Wiring must comply with latest IEE Wiring

Regulations (BS7671)

PERFORMANCE GRAPH

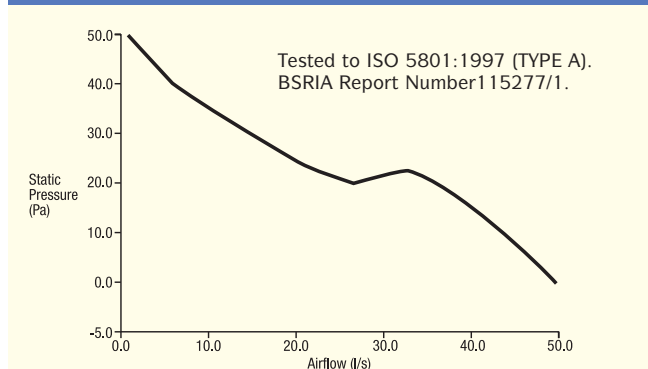

DOMUS 125MM IN-LINE DUCT FANS



- Exceeds Building Regulations for utility rooms, bathrooms and toilets
- Kitemarked to BS EN 60335 for electrical safety
- Tough white high gloss ABS (fire retardant and UV stabilised)
- Stainless steel ball bearing versions
- Quick and easy installation
- Two model options
- Three year guarantee

The DOMUS 125mm mixed flow in-line duct fan has been designed to provide extract over long distances where a high rate of extract is a prerequisite.

The unit is produced in clean white ABS with detachable mounting foot allowing fast trouble free installation.

Model options include: Standard and Timer. Models are also available with a stainless steel ball bearing motor providing greater efficiency, lower noise and longer life.

The 125mm range exceeds the Building Regulations requirements of 30 l/s for utility rooms.



DOMUS 125MM IN-LINE DUCT FANS



Product Code		Description	Extract performance			Power W	dB(A) @ 3m	Weight kg	Model
Boxed	Prepack		l/s	m ³ /hr	cfm				
S12D	n/a	Standard Duct Fans	31	112	66	25	-	0.7	
	n/a	Duct Fan	31	112	66	25	-	0.7	
SB12D	n/a	Duct Fan with Ball Bearing Motor	31	112	66	25	-	0.7	
	n/a	Duct Fan with Ball Bearing Motor	31	112	66	25	-	0.7	
T12D	n/a	Timer Duct Fans	31	112	66	25	-	0.7	
	n/a	Duct Fan	31	112	66	25	-	0.7	
TB12D	n/a	Duct Fan with Ball Bearing Motor	31	112	66	25	-	0.7	
	n/a	Duct Fan with Ball Bearing Motor	31	112	66	25	-	0.7	

ACCESSORIES

Product Code		Description	Fitting size	Specification
Boxed	Prepack			
12DK	n/a	125mm Fixing Kits Ceiling Kit for 125mm in-line fans	3m	Contains white internal and brown external outlet, 3m of flexible hose and fixings.

DIMENSIONS

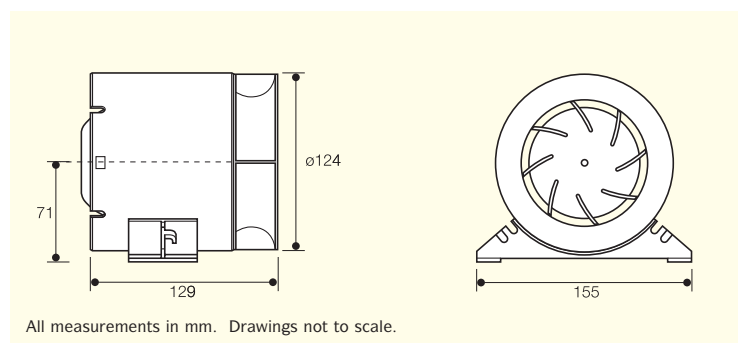

ELECTRICAL SPECIFICATIONS

220-240 V ~ 50Hz

Insulation class II / Double insulated

Drip-proof (equivalent IPx2)

Motors fitted with standard thermal fuses

Wiring must comply with latest
IEE Wiring Regulations (BS7671)

PERFORMANCE GRAPH

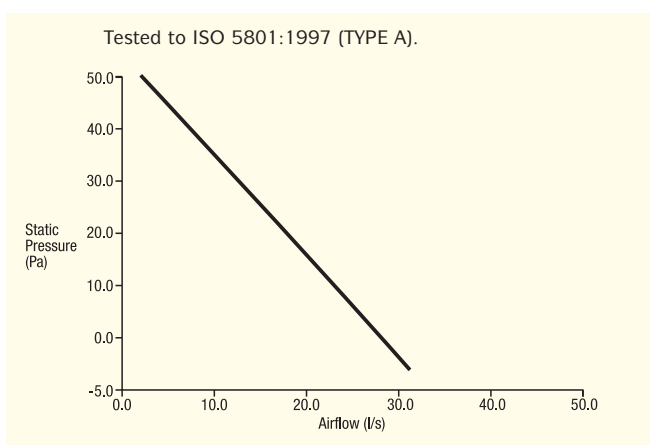

DOMUS 150MM AXIAL FANS



- Exceeds Building Regulations for kitchens, utility rooms and large bathrooms
- Window or wall fixing options
- BSI Kitemarked to BS EN 60335 for electrical safety
- IPx4 Splash-proof rating
- Tough white high gloss ABS (fire retardant and UV stabilised)
- Stainless steel ball bearing versions
- Quick and easy installation
- Multiple model options
- Three year guarantee

The DOMUS 150mm axial fan is a stylish unit made from safe, durable, easily cleaned high gloss ABS. Suitable for wall or window installation.

Model options include: Standard, Pull-cord Switch, Timer, Humidistat (with or without Pull-cord Switch), Movement Detector, Auto Shutter and SELV 12V enabling the range to

meet most installation requirements. Some models are also available with a stainless steel ball bearing motor providing greater efficiency, lower noise and longer life.

The SELV 12V fan used in conjunction with a Domus transformer (see page 74) is suitable for safety critical domestic environments and can, therefore, be safely installed within

zone 1 near a bath or shower, as stated in amendment 3 of BS7671:1992. The transformer must be mounted away from the source of water spray and out of the safety critical area.

The 150mm range exceeds the Building Regulation requirement of 60 l/s for kitchens.



The Domus Auto-Shutter fan is ideal for exposed, cold, dusty or smoky environments, when back draft prevention is vital.

DOMUS 150MM AXIAL FANS



Product Code		Description	Extract performance			Power W	dB(A) @ 3m	Weight kg	Model
Boxed	Prepack		l/s	m ² /hr	cfm				
		Standard Fans							
S15	n/a	Wall Fan	69	248	150	33	48.9	0.8	
SB15	n/a	Wall Fan with Ball Bearing Motor	69	248	150	33	48.9	0.8	
S15W	n/a	Window Fan	61	220	128	33	48.9	0.8	
S15K	n/a	Wall Fan & Wall Fixing Kit	64	230	134	33	48.9	0.8	
		Pull Switch Fans							
P15	P15R	Wall Fan	69	248	150	33	48.9	0.8	
PB15	n/a	Wall Fan with Ball Bearing Motor	69	248	150	33	48.9	0.8	
P15W	P15WR	Window Fan	61	220	128	33	48.9	0.8	
P15K	P15KR	Wall Fan & Wall Fixing Kit	64	230	134	33	48.9	0.8	
		Timer Fans							
T15	n/a	Wall Fan	69	248	150	33	48.9	0.8	
TB15	n/a	Wall Fan with Ball Bearing Motor	69	248	150	33	48.9	0.8	
T15W	n/a	Window Fan	61	220	128	33	48.9	0.8	
T15K	n/a	Wall Fan & Wall Fixing Kit	64	230	134	33	48.9	0.8	
		Movement Detector Fans							
M15	n/a	Wall Fan	69	248	150	33	48.9	0.8	
MB15	n/a	Wall Fan with Ball Bearing Motor	69	248	150	33	48.9	0.8	
		Humidistat Fans							
H15	n/a	Wall Fan	69	248	150	33	48.9	0.8	
H15W	n/a	Window Fan	61	220	128	33	48.9	0.8	
H15K	n/a	Wall Fan & Wall Fixing Kit	64	230	134	33	48.9	0.8	
		Humidistat/Pull Switch Fans							
HP15	n/a	Wall Fan	69	248	150	33	48.9	0.8	
HP15W	n/a	Window Fan	61	220	128	33	48.9	0.8	
HP15K	n/a	Wall Fan & Wall Fixing Kit	64	230	134	33	48.9	0.8	
		Auto Shutter Fans							
AS15	n/a	Standard Wall Fan	69	248	150	39	48.9	0.9	
AP15	n/a	Pull Switch Wall Fan	69	248	150	39	48.9	0.9	
AT15	n/a	Timer Wall Fan	69	248	150	39	48.9	0.9	
		 SELV 12V Fan Wall Fan Requires 12V transformer (see page 74).	69	248	150	33	48.9	0.8	

DOMUS 150MM AXIAL FANS



ELECTRICAL SPECIFICATIONS

220-240 V ~ 50Hz (SELV versions 12 V ~ 50Hz)

Insulation class II / Double insulated

Splash-proof (equivalent IPx4)

Motors fitted with standard thermal fuses

(SELV versions motor fitted with auto-reset thermal cutouts)

Wiring must comply with latest IEE Wiring Regulations (BS7671)



SELV fans provide safety from intense condensation build up.

PERFORMANCE GRAPH

Tested to ISO 5801:1997 (Type A).
BSRIA Report Number 14404/1 03/99.

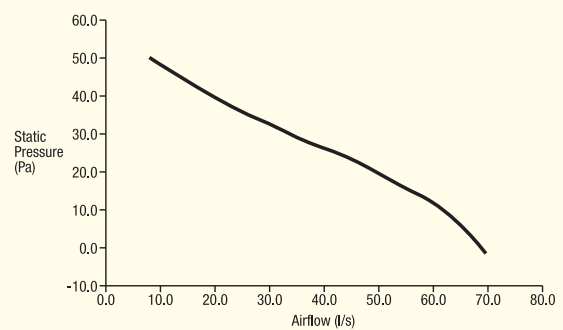

DOMUS 150MM AXIAL FANS

DIMENSIONS

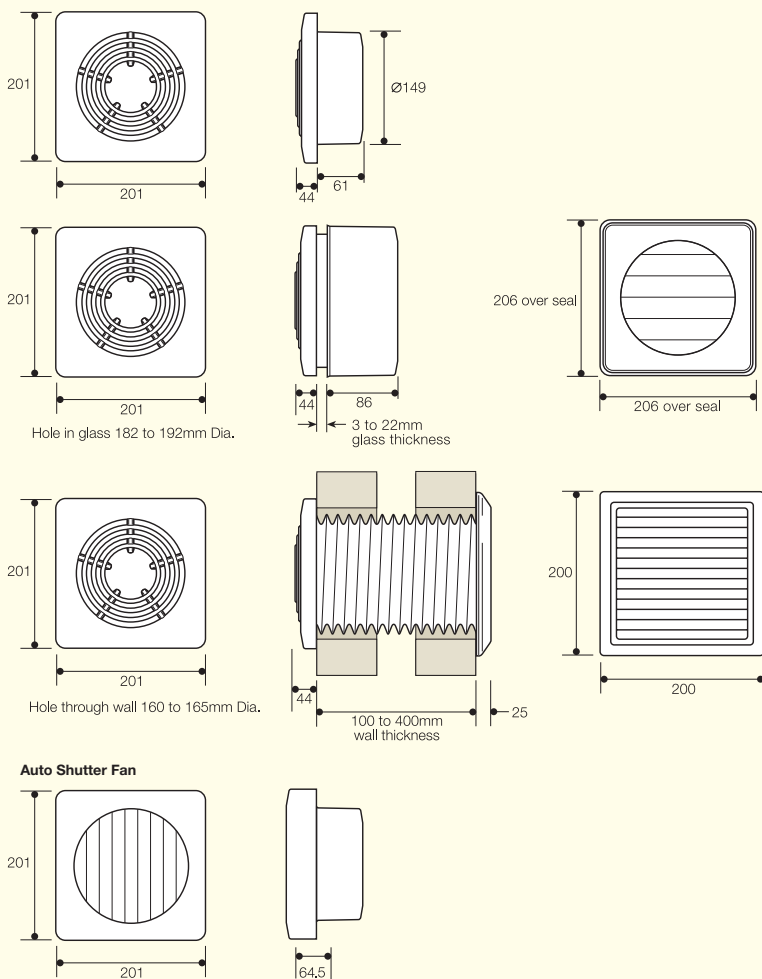

All measurements in mm. Drawings not to scale.



Window fan installation

ACCESSORIES

Product Code	Description	Fitting size	Extract performance			Specification	
Boxed	Prepack		l/s	m ³ /hr	cfm		
15K	15KR	150mm Fixing Kits Wall Fixing Kit for 150mm axial fans	100-400mm	64	230	134	Contains 400mm of compressed aluminium duct and brown external louvred outlet.
15W	15WR	Window Fixing Kit for 150mm axial fans	3-22mm	61	220	128	Contains window gravity flap outlet, seal and fixings.

Boxed	Prepack	Description	Connects to	External Dimensions	Specification
n/a	F15CHR	150mm Interchangeable Fascias Chrome	150mm axial fan	201 x 201mm	For installation with all 150mm axial fans except HP (Humidistat with Pull Switch), M (Movement Detector) and A (Auto Shutter) models.
n/a	F15ALR	Brushed Aluminium	150mm axial fan	201 x 201mm	
n/a	F15GDR	Gold	150mm axial fan	201 x 201mm	

* when installed with appropriate Domus fan.

DOMUS 150MM IN-LINE DUCT FANS



- Exceeds Building Regulations for kitchens, utility rooms and large bathrooms
- BSI Kitemarked to BS EN 60335 for electrical safety
- Tough white high gloss ABS (fire retardant and UV stabilised)
- Stainless steel ball bearing versions
- Quick and easy installation
- Two model options
- Three year guarantee

The DOMUS 150mm mixed flow in-line duct fan has been designed to provide extract over long distances where a high rate of extract is a prerequisite.

The unit is produced in clean white ABS with detachable mounting foot allowing fast trouble free installation.

Models include: Standard and Timer versions. Models are also available with a stainless steel ball bearing motor providing greater efficiency, lower noise and longer life.

The 150mm range exceeds the Building Regulations requirements of 60 l/s for kitchens.



IN-LINE MIXED FLOW FANS

The Domus in-line duct fans utilise a mixed flow blade designed for air movement over medium distances (2 to 4m). A mixed flow impeller combines the features of a centrifugal and normal axial fan and the higher pressure generated allows it to move air over longer distances.

DOMUS 150MM IN-LINE DUCT FANS



Product Code		Description	Extract performance			Power	dB(A)	Weight	Model
Boxed	Prepack		l/s	m ³ /hr	cfm	W	@ 3m	kg	
S15D	n/a	Standard Duct Fans	62	224	130	33	-	0.7	
	SB15D	Duct Fan with Ball Bearing Motor	62	224	130	33	-	0.7	
T15D	n/a	Timer Duct Fans	62	224	130	33	-	0.7	
	TB15D	Duct Fan with Ball Bearing Motor	62	224	130	33	-	0.7	

ACCESSORIES

Product Code		Description	Fitting size	Specification
Boxed	Prepack			
15DK	n/a	150mm Fixing Kits Ceiling Kit for 150mm in-line fans	3m	Contains white internal and brown external outlet, 3m of flexible hose and fixings.

DIMENSIONS

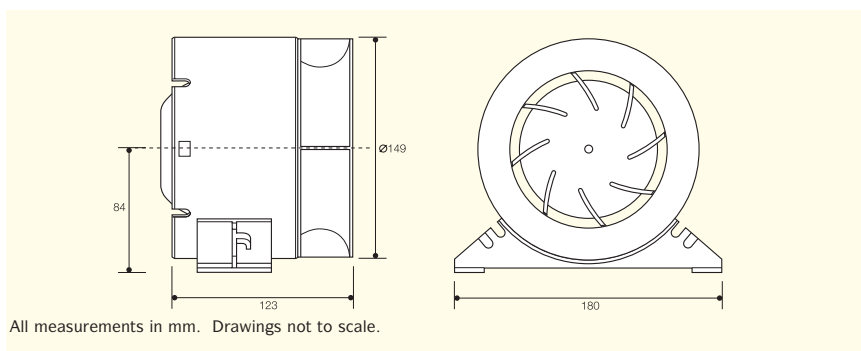

ELECTRICAL SPECIFICATIONS

220-240 V ~ 50Hz

Insulation class II / Double insulated

Drip-proof (equivalent IPx2)

Motors fitted with standard thermal fuses

Wiring must comply with latest IEE Wiring Regulations (BS7671)

PERFORMANCE GRAPH

Tested to ISO 5801:1997 (Type A).

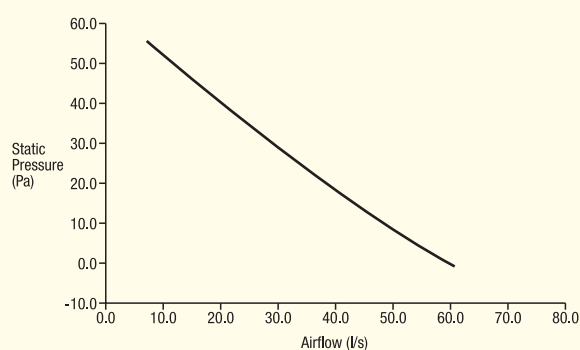

DOMUS 12 VOLT TRANSFORMERS



The DOMUS range of 12 Volt transformers must be used when installing a Domus SELV axial fan (see pages 54, 65 and 69). Transformers must be mounted away from any source of water spray and out of the safety critical area (zone 0,1 or 2 as stated in amendment 3 of BS7671:1992).

The transformers are fitted with multiple control options to suit the whole Domus SELV range of fans and incorporate a green LED to indicate that the system is in operation.

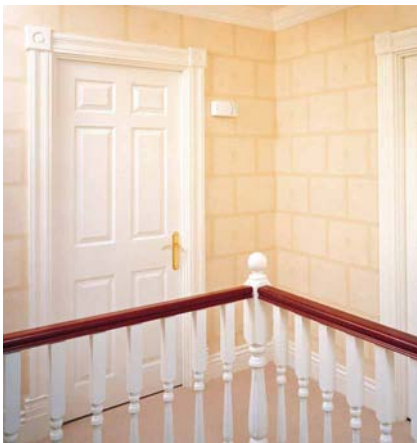

A typical installation of a Domus VS 12 Volt Transformer

Product Code		Description	Model
Boxed	Prepack		
VS	n/a	12 Volt Transformer - Standard Transformers are designed for remote operation.	
VP	n/a	12 Volt Transformer - Pull Switch Transformers have the addition of a pull-cord for manual operation.	
VT	n/a	12 Volt Transformer - Timer Transformers are fitted with a remotely operated electronic overrun timer adjustable from 1 to 25 minutes.	
VH	n/a	12 Volt Transformer - Humidistat Transformers are fitted with an integral condensation control facility, adjustable between 60 and 80% RH, which enables the fan to continuously monitor humidity levels. These models also incorporate the overrun timer installed in VT models to facilitate remote operation.	
VHP	n/a	12 Volt Transformer - Humidistat/Pull Switch Models have the same control options as the VH with the addition of a pull-cord switch and green LED indicator to provide a manual override.	

Transformers are available in retail packaging with a SELV fan and complete installation kit - see page 54 for details.

DIMENSIONS

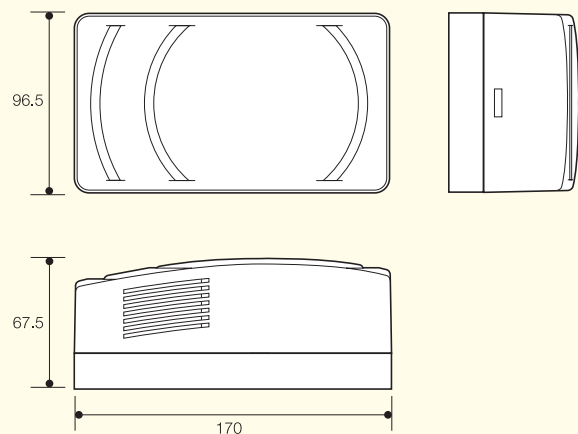

All measurements in mm. Drawings not to scale.

MULTI ROOM EXTRACT SYSTEM

- Low running cost
- Complies with the Building Regulations (BRE Digest 398)
- Adaptable for different installations
- Can be wired for 2 speed operation
- Includes installation kit
- Easy to install
- Exceptionally quiet in operation
- 2 year guarantee



The DOMUS Multi Room Extract (MRE) system is a stylish and compact unit that provides a highly efficient and low cost form of continuous and controlled domestic ventilation from a single extraction unit. Its adaptability enables the system to be suitable for common house layouts and can be used in up to five rooms.

The MRE system prevents the need for multiple fans in different rooms and reduces, to one, the number of external outlets required.

A two speed* ball bearing motor is fitted to ensure long life and efficiency. The second speed acts as a powerful extraction boost which should be used when the removal of moisture and unwanted air is most needed e.g. after a bath or during cooking.

The 80mm inlets are for use in the bathroom or WC and the 125mm inlet should be used in the kitchen.

Fan spigots are fitted with flow regulators to balance the system. A simple to operate cursor device regulates the airflow in the kitchen.

The MRE system is normally installed in the loft or ceiling void and can be either fixed to a solid object (such as a joist or pillar) with a bracket, or it can be suspended with the cord provided in the kit.

Suspending the system

has the benefit of reducing unnecessary noise vibration.

Remember that extraction systems remove air from the building and in order to balance the airflow, provision must be made for replacement air.

**A single pole changeover switch is required.*



MULTI ROOM EXTRACT SYSTEM



Product Code		Description	Extract performance			Power W	Weight kg	Electrical Specification
Boxed	Prepack		l/s	m ³ /hr	cfm			
MREK	n/a	Multi-Room Extractor Kit Two speed operation Low Speed High Speed	58 103	210 370	122 216	27 90	2.4	Electricity Supply 220 - 240V~50 Hz

The internal fan system of the unit is of the external rotor motor type designed for durability with low maintenance levels. The impeller generates high pressure levels to overcome duct resistance, but also minimises indoor sound levels to almost inaudible levels.

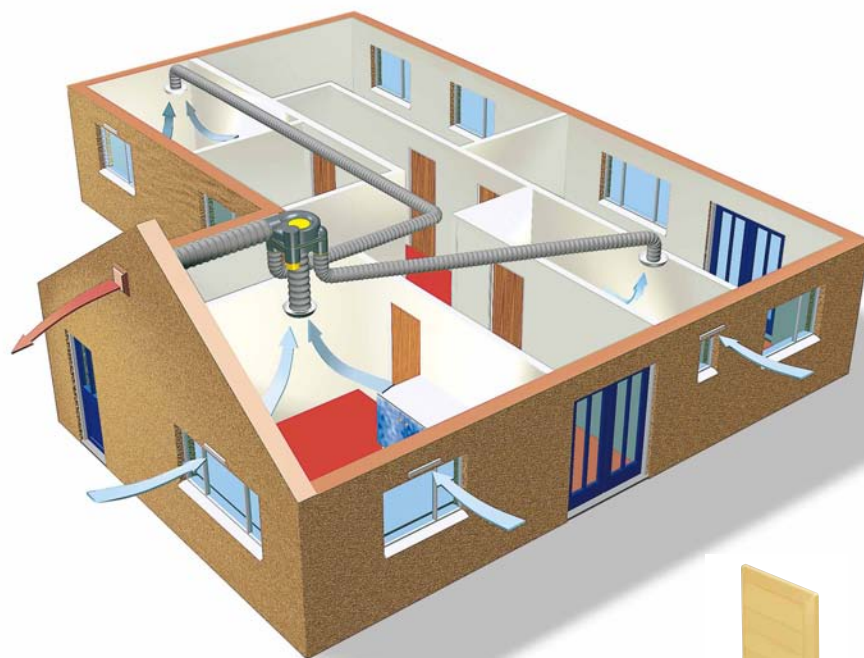

The system comes supplied as a kit with:

- 4 x 6m lengths of 80mm dia. PVC flexible hose
- 2 x 6m lengths of 125mm dia. PVC flexible hose
- 4 x 80mm dia. inlet (white)
- 1 x 125mm dia. inlet (white)
- Suspension cord
- Installation instructions

N.B. External outlet is not included. Please refer to the Ducting section (pages 9-13 for options).



5900 Gravity Flap Outlet



5902 Cowled Outlet



5904 Louvred Grille

The Domus MREK is only available for sale within the British Isles.

DIMENSIONS & PERFORMANCE GRAPH

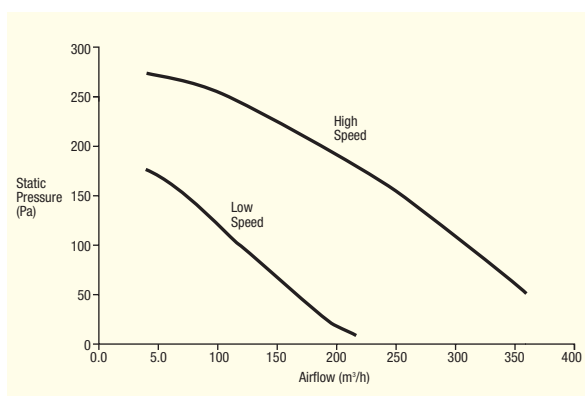

- Exceptional value for money
- Exceeds Building Regulations for bathrooms and toilets
- Wall fixing option
- IPx4 Splash-proof rating
- Three model options
- Easy installation
- Three year guarantee



Low Cost No Frills

ELF

ELF is a 'no frills' range that still provides the basic requirements for a simple domestic installation and, of course, exceeds the Building Regulations. An excellent alternative to the higher specification standard Domus range of fans.

The ELF fan range is a new generation of economy extractor fan. It provides high performance and offers exceptional value for money.

The ELF has been designed with ease of installation and simplicity in mind, making it extremely contractor friendly. It is also discreet and has a footprint of only 140mm x 140mm.

ELF can be installed in bathrooms or WCs, as it exceeds the Building Regulations for these rooms and can be wall or ceiling mounted. Models include: Standard, Timer and Humidistat versions.

Available in robust boxes with clear colour coded model identification labels it is suitable for installation with Domus ducting components and fan accessories.





Product Code	Description	Extract performance			Power W	dB(A) @3m	Weight kg	Model		
		Boxed	Prepack	I/s					m ³ /hr	cfm
ELFS	Standard ELF Fan		n/a	18	65	38	19	41.4	0.5	
ELFT	Timer ELF Fan		n/a	18	65	38	19	41.4	0.5	
ELFH	Humidistat ELF Fan		n/a	18	65	38	19	41.4	0.5	
ELFK	Wall Fixing Kit for use with ELF		n/a	18	65	38	19	41.4	0.5	

Wall Fixing Kit contains 400mm of compressed aluminium duct and brown external louvred outlet (plus flaps for conversion to a gravity flap outlet if preferred). Performance figures shown for ELFK are when installed with an ELF fan.

Standard

Switch fan on/off manually by remote switch e.g. light switch.

Timer

Fan switches on using a remote switch (light) and includes an adjustable overrun timer (1 to 25 mins) so that the fan continues to remove excess moisture and odours after switching off the fan

Humidistat

Switches on/off automatically once a preset level of humidity is reached. Also includes timer function. Condensation control is adjustable between 60 & 80% RH @ 21°C which enables the fan to continuously monitor humidity levels.

Fascias from the standard range of Domus fans are not compatible with ELF
Not suitable for window installation

DIMENSIONS

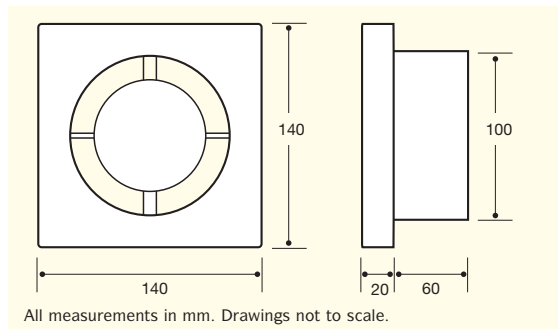

ELECTRICAL SPECIFICATIONS

- 220-240 V ~ 50Hz
- Insulation class II / Double insulated
- Splashproof (equivalent IPx4)
- Motors fitted with standard thermal fuses
- Wiring must comply with latest IEE Wiring Regulations (BS7671)

PERFORMANCE GRAPH

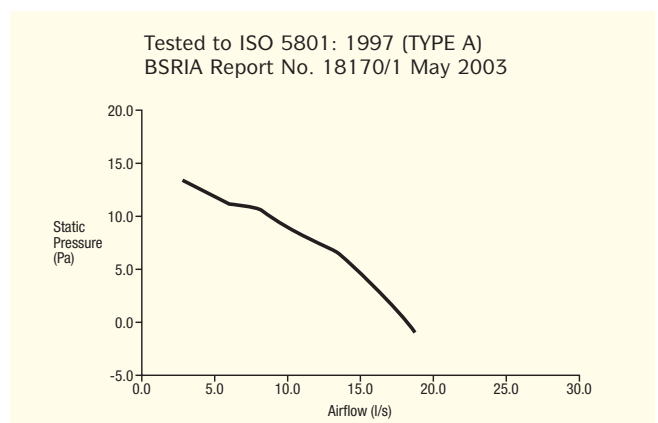

X-ON Electronics

Largest Supplier of Electrical and Electronic Components

Click to view similar products for [DOMUS](#) manufacturer:

Other Similar products are found below :

[DOMUS](#)