



FLOW



TEMPERATURE



HUMIDITY

Flow Sens FS1L / FS1LA

Thermal Mass Flow Sensor for all-purpose use in Liquids

Product

The Flow Sens is the result of continuous development of IST AG quality products. The layout of the Sensor that is optimised for measurements in dielectric liquids like oil or pure water. It consists of two temperature depending platinum-resistors, both deposited on one chip. The low-ohm resistor with a small area is used as a heater, whereas the other high-ohm resistor serves to measure the reference temperature. Using a bridge circuit, the differing resistance value of two elements leads to different (self) heating. The (self) heating is dependent upon the applied voltage, the mass flow, and the media in which the sensor is located. Higher voltage increases self heating, a higher flow rate increases cooling. If the self heating is kept constantly by a suitable controller, the voltage increases with higher flow rates and therefore becomes a measure for the mass flow. As a result of his little thermal mass, this sensor has fast heating and cooling response times. The measuring principle of the sensor can be used for large operation ranges. The Flow Sens is also available with a plastic housing of \varnothing 6mm. This option provides the user with ideal opportunities to incorporate the element into custom-built applications or specific housings, e.g. into a T-piece.

Advantages

- Easy adaptable for different applications or into housings
- Simple signal processing and calibration
- Insensitive to contamination
- No moving parts
- Excellent reproducibility
- Excellent long -term stability
- Best price-performance ratio

Applications

- HVAC and building control solutions
- Automotive industry
- Medical devices
- Device monitoring
- Cooling devices
- Food industry



INNOVATIVE SENSOR TECHNOLOGY

IST AG, Industriestrasse 2, CH-9630 Wattwil, Switzerland, Phone (+)41 71 987 73 73, Fax (+)41 71 987 73 77
e-mail info@ist-ag.com, www.ist-ag.com



Flow Sens FS1L / FS1LA

Thermal Mass Flow Sensor for all-purpose use in Liquids

Technical Data

Measuring principle	thermal
Measuring range	0.01 ... 10 m/s (higher rates upon request)
Accuracy	< 3% current measuring value (dependent on electronic and calibration)
Warm up time	< 1 min (depending on mounting)
Response time	< 100 ms (depending on velocity and dT)
Temperature range	-30 ... + 150 °C
Temperature sensitivity	< 0.1 %/K (dependent on electronic)
Electrical connection	3 pins, Leads AWG30, insulated with PTFE, or custom specific
Heater	$R_H(0^\circ\text{C}) = 45 \ \Omega \pm 1\%$
Referenz element	$R_S(0^\circ\text{C}) = 1200 \ \Omega \pm 1\%$
Required Voltages	typical 0 - 10 V at dT = 10 K
Dielectric strength	$\pm 10 \text{ V}$ (! heater rating ! dependent on flow)
Substrate material	Al ₂ O ₃ ceramic

In general All data are temporary and valid in pure water. Other media and higher requirements upon request. No responsibility accepted.

Construction size

FS1L.0.1L.195



FS1L.A.1L.195

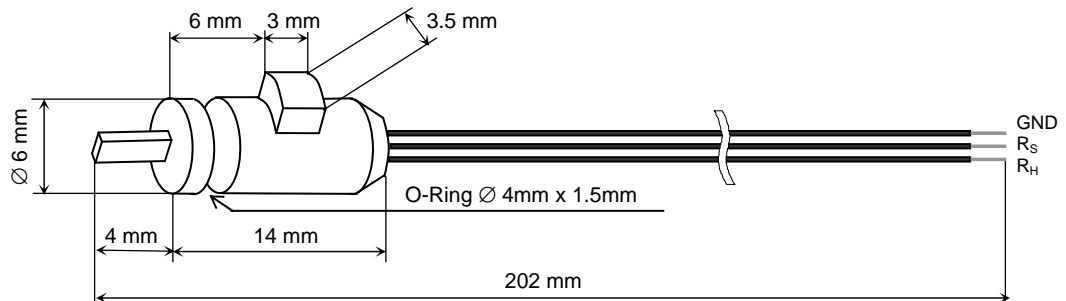

INNOVATIVE SENSOR TECHNOLOGY



Flow Sens FS1L / FS1LA

Thermal Mass Flow Sensor for all-purpose use in Liquids

Electronic circuit recommendation

As shown on the scheme to the right, the heater R_H and sensor R_S need to be connected in a bridge circuit. It is essential to determine the correct values of the resistors R_1 , R_2 , and R_3 . The bridge is in balance as soon as the desired temperature difference between R_S and R_H has reached e.g. 10K. At a changing flow the bridge voltage U_{Bs} needs to be controlled in dependence of the bridge balance V_1 - V_2 . The values for R_1 ... R_3 are depending on the temperature difference dT and the medium which should be measured. We will provide you with the values of R_1 ... R_3 , depending on the application.

For calibration the R_2 needs to be adjusted within a range of $\pm 5\%$.

The method of adjustment relies on the application.

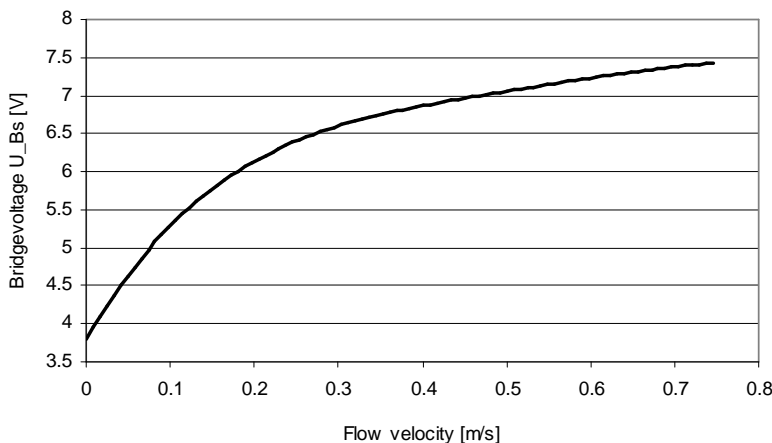
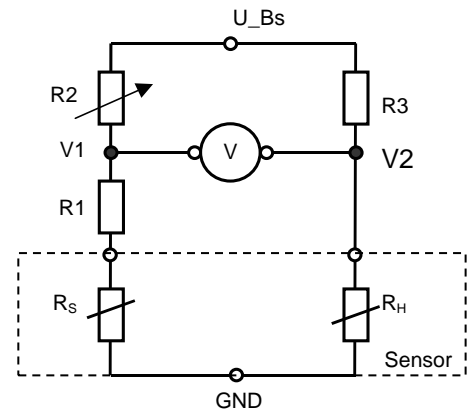

Typical signal – curve between 0 0.8 m/s

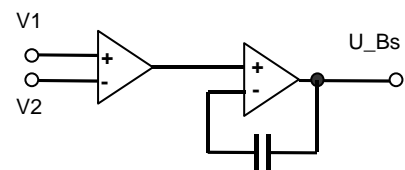

Principle of the heating controller

Option

The electric connection can be provided customer-specific.

If a connector is requested we provide e.g. the JST connector EHR-3 with 3 pins, polarized and with a latch locking system.

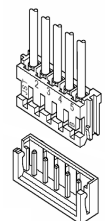

INNOVATIVE SENSOR TECHNOLOGY



X-ON Electronics

Largest Supplier of Electrical and Electronic Components

Click to view similar products for Ist Innovative Sensor manufacturer:

Other Similar products are found below :

[HYT 939](#) [TSIC 301 TO92](#) [TSIC 506F TO92](#) [P0K1.161.1E.B.200](#) [P0K1.520.6W.Y.010](#) [P14 FEMTOCAP-G](#) [P0K1.520.6W.A.010](#)
[P0K1.281.6W.B.007](#) [TSIC 306 SOP-8](#) [P1K0.308.7W.B.007](#) [P0K1.516.7W.B.010](#) [P0K1.520.6W.B.010](#) [TSIC 301 SOP-8](#) [P1K0.520.6W.Y.010](#)
[HYT 271](#) [ND1K0.520.2FW.B.007](#) [P0K1.232.4W.K.010](#) [P0K1.232.2I.B.050](#) [P0K1.161.6W.B.010](#) [P0K1.202.3K.A.010](#) [P1K0.161.6W.A.010](#)
[P0K1.202.3FW.B.007](#) [P1K0.1206.2P.A](#) [P0K1.1206.2P.A](#) [P10K.520.6W.B.010.D](#) [HYT 221](#) [P0K1.1206.2P.B](#) [P0K1.232.6W.A.010](#)
[P1K0.1206.2P.B](#) [P1K0.232.6W.B.010](#) [TSIC 306 TO92](#) [P0K1.0805.2P.B](#) [P1K0.0805.2P.B](#)