

DATA SHEET

TYF LED CoB CL High Efficacy Series

70-, 80-, 90- minimum CRI optional

From 3 to 200w

Mirro-Like Aluminum

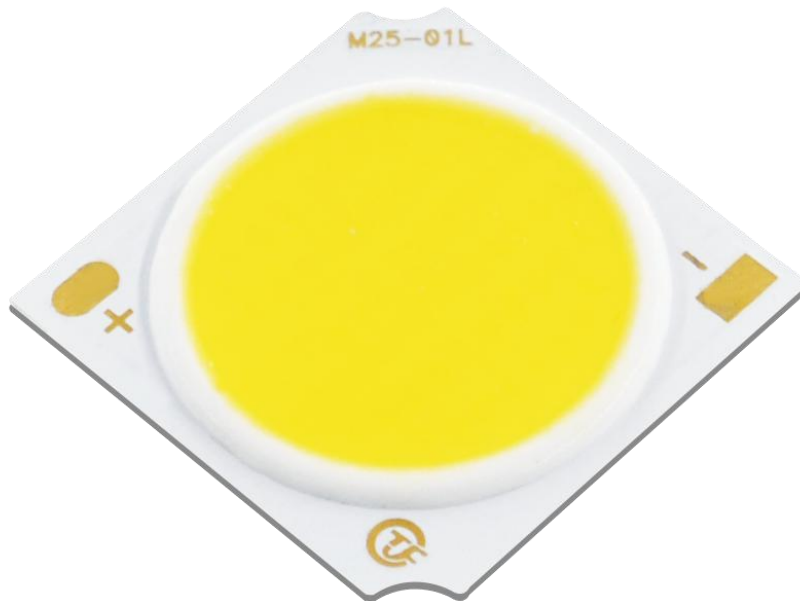

Table of Contents

Introduction.....	3
1.1 Features.....	3
1.2 Benefits.....	3
1.3 Mechanical Dimension.....	4
1.4 Product Nomenclature.....	4
Performance Characteristics.....	5
2.1 Product Selection Guide.....	5
CL13111201P4.....	5
CL13111202P4.....	6
CL13111203P4.....	7
CL13111204P4.....	8
CL25171205P4.....	9
CL25171206P4.....	10
CL25171208P4.....	11
CL25171210P4.....	12
CL36241211P4.....	13
CL36241212P4.....	14
CL36241216P4.....	15
CL36241812P4.....	16
CL36241818P4.....	17
CL54351818P4.....	18
CL54351825P4.....	19
2.2 Electrical Characteristics.....	20
2.3 Color Binning Information.....	21
2.4 Absolute Maximum Ratings.....	22
Performance Curves.....	23
3.1 Characteristic Curves.....	23
3.2 Optical Curves.....	24
3.3 The Relative Spectral Distribution Graph.....	25
Reliability Test.....	27
Packaging and Labeling.....	28
Precautions.....	29
About TYF.....	30

Introduction

TongYiFang(TYF) CoB LED array products deliver high quality light in a compact and cost-effective solid state lighting package. Our advanced packaging technology and private phosphor combination has excellent reliability. Lighting system designs incorporating these LED arrays deliver increased system level efficacy and longer service life.

Our CoB Series cover a wide range of luminous from 3W to 500W lamp for general lighting, automotive lighting and other special applications. The CoB LED array is also available in a variety of CCT and CRI combinations providing substantial design flexibility and energy efficiency.

TYF CoB LEDs are hot-tested at 85° C, luminaire design can be simplified and testing can be minimized.

1.1 Features

- Efficacy of 155 lm/W typical for 3000K, 80CRI
- Compact high flux density light source
- Uniform, high quality illumination
- Minimum 70, 80, and 90 CRI options
- StreaCLined thermal path
- ENERGY STAR® / ANSI compliant color binning structure with 2, 3 and 5 SDCM standard
- More energy efficient than incandescent, halogen and fluorescent lamps
- High voltage or Low voltage DC operation
- Product series and company logo on the front
- RoHS compliant

1.2 Benefits

- Enhanced optical control
- High quality, true color reproduction
- Significantly reduced thermal resistance and increased operating temperature
- Uniform, consistent white light
- Lower operating cost
- Easy to use with daylight and motion detectors to enable increased energy saving
- Reduced maintenance cost
- Environmentally friendly, no disposal issue

1.3 Mechanical Dimension

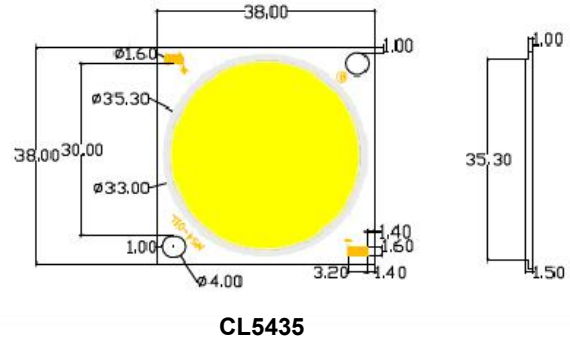
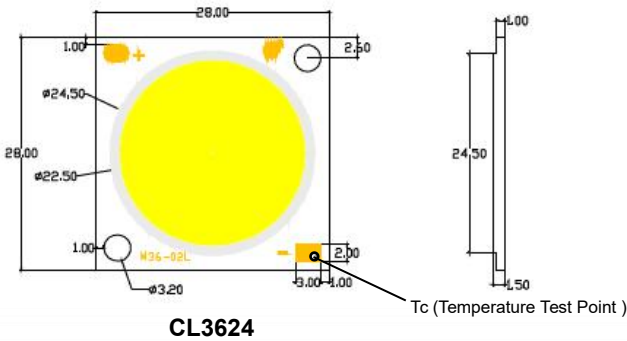
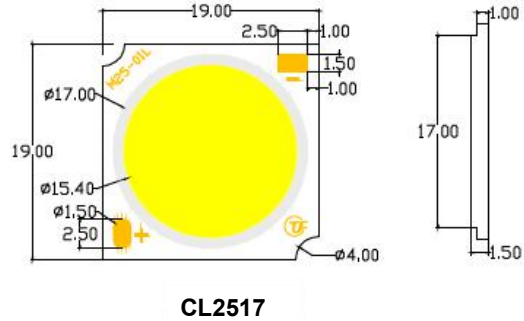
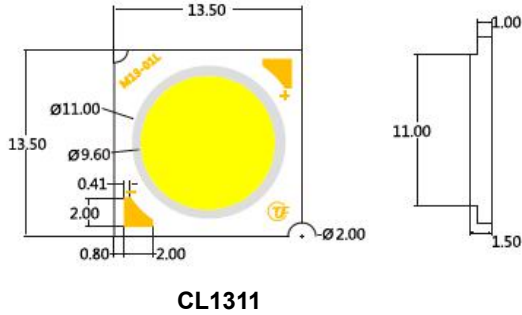

Notes:

1. All dimension tolerance is $\pm 0.2\text{mm}$ unless otherwise noted.
2. Tc measurement point at cathode pad of product.

1.4 Product Nomenclature

The part number designation for TYF CL Series LED arrays is explained as follows:

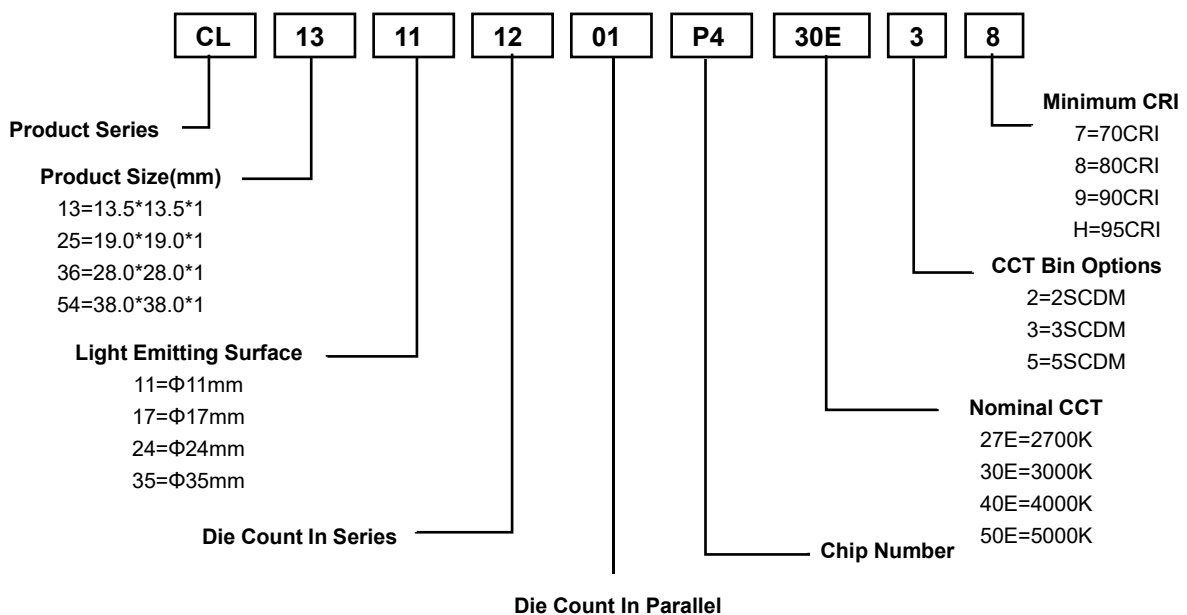

Performance Characteristics

2.1 Product Selection Guide

Table 1: Electro-Optical Characteristics at Tj=85°C

Part Number	Typical Power (W)	Nominal CCT (K)	CRI	Minimum Pulsed Flux (lm)	Typical Pulsed Flux (lm)	Typical Voltage (V)	Nominal Current (mA)	Typical Efficacy (lm/W)
CL13111201P430E*7	3.1	3000 K	70	476	512	34	90	165
CL13111201P435E*7	3.1	3500 K	70	484	521	34	90	168
CL13111201P440E*7	3.1	4000 K	70	493	530	34	90	171
CL13111201P450E*7	3.1	5000 K	70	499	536	34	90	173
CL13111201P457E*7	3.1	5700 K	70	504	543	34	90	175
CL13111201P465E*7	3.1	6500 K	70	498	543	34	90	173
CL13111201P422E*8	3.1	2200 K	80	398	428	34	90	138
CL13111201P427E*8	3.1	2700 K	80	427	459	34	90	148
CL13111201P430E*8	3.1	3000 K	80	447	481	34	90	155
CL13111201P435E*8	3.1	3500 K	80	453	487	34	90	157
CL13111201P440E*8	3.1	4000 K	80	461	496	34	90	160
CL13111201P450E*8	3.1	5000 K	80	467	502	34	90	162
CL13111201P457E*8	3.1	5700 K	80	470	505	34	90	163
CL13111201P465E*8	3.1	6500 K	80	464	498	34	90	161
CL13111201P422E*9	3.1	2200 K	90	340	366	34	90	118
CL13111201P427E*9	3.1	2700 K	90	366	394	34	90	127
CL13111201P430E*9	3.1	3000 K	90	383	412	34	90	133
CL13111201P435E*9	3.1	3500 K	90	392	422	34	90	136
CL13111201P440E*9	3.1	4000 K	90	398	428	34	90	138
CL13111201P450E*9	3.1	5000 K	90	401	431	34	90	139
CL13111201P457E*9	3.1	5700 K	90	401	431	34	90	139

Notes for Table 1:

1. Nominal CCT as defined by ANSI C78.377-2015.
2. Products tested based on operation under DC(Direct current) with LED array mounted onto a heat sink with thermal interface material and Tj (junction temperature) = 85° C. Base on TYF test set up, values also depending on the thermal design and exposed environment to which the luminaire is subjected.
3. Typical performance values are provided as a reference only and are not a guarantee of performance.
4. TYF maintains a ±7% tolerance on flux measurements. ±3% tolerance on voltage measurements. ± 2 RA tolerance on Ra measurements.
5. Alternate drive currents are provided for reference only and are not a guarantee of performance.
6. $\Phi_{25^{\circ}\text{C}} = \Phi_{85^{\circ}\text{C}} / 0.895$

Performance Characteristics

Table 2: Electro-Optical Characteristics at Tj=85°C

Part Number	Typical Power (W)	Nominal CCT (K)	CRI	Minimum Pulsed Flux (lm)	Typical Pulsed Flux (lm)	Typical Voltage (V)	Nominal Current (mA)	Typical Efficacy (lm/W)
CL13111202P430E*7	6.1	3000 K	70	925	994	34	180	163
CL13111202P435E*7	6.1	3500 K	70	942	1013	34	180	166
CL13111202P440E*7	6.1	4000 K	70	953	1025	34	180	168
CL13111202P450E*7	6.1	5000 K	70	970	1043	34	180	171
CL13111202P457E*7	6.1	5700 K	70	981	1055	34	180	173
CL13111202P465E*7	6.1	6500 K	70	970	1043	34	180	171
CL13111202P422E*8	6.1	2200 K	80	772	830	34	180	136
CL13111202P427E*8	6.1	2700 K	80	828	891	34	180	146
CL13111202P430E*8	6.1	3000 K	80	868	933	34	180	153
CL13111202P435E*8	6.1	3500 K	80	879	946	34	180	155
CL13111202P440E*8	6.1	4000 K	80	891	958	34	180	157
CL13111202P450E*8	6.1	5000 K	80	908	976	34	180	160
CL13111202P457E*8	6.1	5700 K	80	908	976	34	180	160
CL13111202P465E*8	6.1	6500 K	80	902	970	34	180	159
CL13111202P422E*9	6.1	2200 K	90	658	708	34	180	116
CL13111202P427E*9	6.1	2700 K	90	709	763	34	180	125
CL13111202P430E*9	6.1	3000 K	90	743	799	34	180	131
CL13111202P435E*9	6.1	3500 K	90	760	817	34	180	134
CL13111202P440E*9	6.1	4000 K	90	772	830	34	180	136
CL13111202P450E*9	6.1	5000 K	90	777	836	34	180	137
CL13111202P457E*9	6.1	5700 K	90	777	836	34	180	137

Notes for Table 2:

1. Nominal CCT as defined by ANSI C78.377-2015.
2. Products tested based on operation under DC(Direct current) with LED array mounted onto a heat sink with thermal interface material and Tj (junction temperature) = 85° C. Base on TYF test set up, values also depending on the thermal design and exposed environment to which the luminaire is subjected.
3. Typical performance values are provided as a reference only and are not a guarantee of performance.
4. TYF maintains a ±7% tolerance on flux measurements. ±3% tolerance on voltage measurements. ± 2 RA tolerance on Ra measurements.
5. Alternate drive currents are provide for reference only and are not a guarantee of performance.
6. $\Phi_{25^{\circ}\text{C}} = \Phi_{85^{\circ}\text{C}} / 0.895$

Performance Characteristics

Table 3: Electro-Optical Characteristics at Tj=85°C

Part Number	Typical Power (W)	Nominal CCT (K)	CRI	Minimum Pulsed Flux (lm)	Typical Pulsed Flux (lm)	Typical Voltage (V)	Nominal Current (mA)	Typical Efficacy (lm/W)
CL13111203P430E*7	9.2	3000 K	70	1378	1481	34	270	161
CL13111203P435E*7	9.2	3500 K	70	1403	1509	34	270	164
CL13111203P440E*7	9.2	4000 K	70	1420	1527	34	270	166
CL13111203P450E*7	9.2	5000 K	70	1446	1555	34	270	169
CL13111203P457E*7	9.2	5700 K	70	1463	1573	34	270	171
CL13111203P465E*7	9.2	6500 K	70	1446	1555	34	270	169
CL13111203P422E*8	9.2	2200 K	80	1147	1233	34	270	134
CL13111203P427E*8	9.2	2700 K	80	1232	1325	34	270	144
CL13111203P430E*8	9.2	3000 K	80	1292	1389	34	270	151
CL13111203P435E*8	9.2	3500 K	80	1309	1408	34	270	153
CL13111203P440E*8	9.2	4000 K	80	1326	1426	34	270	155
CL13111203P450E*8	9.2	5000 K	80	1352	1454	34	270	158
CL13111203P457E*8	9.2	5700 K	80	1360	1463	34	270	159
CL13111203P465E*8	9.2	6500 K	80	1352	1454	34	270	158
CL13111203P422E*9	9.2	2200 K	90	975	1049	34	270	114
CL13111203P427E*9	9.2	2700 K	90	1052	1132	34	270	123
CL13111203P430E*9	9.2	3000 K	90	1104	1187	34	270	129
CL13111203P435E*9	9.2	3500 K	90	1129	1214	34	270	132
CL13111203P440E*9	9.2	4000 K	90	1147	1233	34	270	134
CL13111203P450E*9	9.2	5000 K	90	1155	1481	34	270	135
CL13111203P457E*9	9.2	5700 K	90	1163	1492	34	270	136

Notes for Table 3:

1. Nominal CCT as defined by ANSI C78.377-2015.
2. Products tested based on operation under DC(Direct current) with LED array mounted onto a heat sink with thermal interface material and Tj (junction temperature) = 85° C. Base on TYF test set up, values also depending on the thermal design and exposed environment to which the luminaire is subjected.
3. Typical performance values are provided as a reference only and are not a guarantee of performance.
4. TYF maintains a ±7% tolerance on flux measurements. ±3% tolerance on voltage measurements. ± 2 RA tolerance on Ra measurements.
5. Alternate drive currents are provided for reference only and are not a guarantee of performance.
6. $\Phi_{25^{\circ}\text{C}} = \Phi_{85^{\circ}\text{C}} / 0.895$

Performance Characteristics

Table 4: Electro-Optical Characteristics at Tj=85°C

Part Number	Typical Power (W)	Nominal CCT (K)	CRI	Minimum Pulsed Flux (lm)	Typical Pulsed Flux (lm)	Typical Voltage (V)	Nominal Current (mA)	Typical Efficacy (lm/W)
CL13111204P430E*7	12.2	3000 K	70	1793	1928	34	360	158
CL13111204P435E*7	12.2	3500 K	70	1827	1964	34	360	161
CL13111204P440E*7	12.2	4000 K	70	1861	2001	34	360	164
CL13111204P450E*7	12.2	5000 K	70	1883	2025	34	360	166
CL13111204P457E*7	12.2	5700 K	70	1895	2037	34	360	167
CL13111204P465E*7	12.2	6500 K	70	1883	2025	34	360	166
CL13111204P422E*8	12.2	2200 K	80	1520	1635	34	360	134
CL13111204P427E*8	12.2	2700 K	80	1611	1732	34	360	142
CL13111204P430E*8	12.2	3000 K	80	1679	1806	34	360	148
CL13111204P435E*8	12.2	3500 K	80	1702	1830	34	360	150
CL13111204P440E*8	12.2	4000 K	80	1725	1854	34	360	152
CL13111204P450E*8	12.2	5000 K	80	1747	1879	34	360	154
CL13111204P457E*8	12.2	5700 K	80	1736	1867	34	360	153
CL13111204P465E*8	12.2	6500 K	80	1736	1867	34	360	153
CL13111204P422E*9	12.2	2200 K	90	1271	1366	34	360	112
CL13111204P427E*9	12.2	2700 K	90	1373	1476	34	360	121
CL13111204P430E*9	12.2	3000 K	90	1441	1549	34	360	127
CL13111204P435E*9	12.2	3500 K	90	1464	1574	34	360	129
CL13111204P440E*9	12.2	4000 K	90	1475	1586	34	360	130
CL13111204P450E*9	12.2	5000 K	90	1486	1598	34	360	131
CL13111204P457E*9	12.2	5700 K	90	1498	1610	34	360	132

Notes for Table 4:

1. Nominal CCT as defined by ANSI C78.377-2015.
2. Products tested based on operation under DC(Direct current) with LED array mounted onto a heat sink with thermal interface material and Tj (junction temperature) = 85° C. Base on TYF test set up, values also depending on the thermal design and exposed environment to which the luminaire is subjected.
3. Typical performance values are provided as a reference only and are not a guarantee of performance.
4. TYF maintains a ±7% tolerance on flux measurements. ±3% tolerance on voltage measurements. ± 2 RA tolerance on Ra measurements.
5. Alternate drive currents are provided for reference only and are not a guarantee of performance.
6. $\Phi_{25^{\circ}\text{C}} = \Phi_{85^{\circ}\text{C}} / 0.895$

Performance Characteristics

Table 5: Electro-Optical Characteristics at T_j=85°C

Part Number	Typical Power (W)	Nominal CCT (K)	CRI	Minimum Pulsed Flux (lm)	Typical Pulsed Flux (lm)	Typical Voltage (V)	Nominal Current (mA)	Typical Efficacy (lm/W)
CL25171205P430E*7	15.3	3000 K	70	2348	2525	34	450	165
CL25171205P435E*7	15.3	3500 K	70	2376	2555	34	450	167
CL25171205P440E*7	15.3	4000 K	70	2419	2601	34	450	170
CL25171205P450E*7	15.3	5000 K	70	2447	2632	34	450	172
CL25171205P4*7E*7	15.3	5700 K	70	2462	2647	34	450	173
CL25171205P465E*7	15.3	6500 K	70	2447	2632	34	450	172
CL25171205P422E*8	15.3	2200 K	80	1964	2111	34	450	138
CL25171205P427E*8	15.3	2700 K	80	2106	2264	34	450	148
CL25171205P430E*8	15.3	3000 K	80	2191	2356	34	450	154
CL25171205P435E*8	15.3	3500 K	80	2220	2387	34	450	156
CL25171205P440E*8	15.3	4000 K	80	2248	2417	34	450	158
CL25171205P450E*8	15.3	5000 K	80	2277	2448	34	450	160
CL25171205P457E*8	15.3	5700 K	80	2291	2462	34	450	161
CL25171205P465E*8	15.3	6500 K	80	2277	2448	34	450	160
CL25171205P422E*9	15.3	2200 K	90	1707	1836	34	450	120
CL25171205P427E*9	15.3	2700 K	90	1821	1958	34	450	128
CL25171205P430E*9	15.3	3000 K	90	1892	2035	34	450	133
CL25171205P435E*9	15.3	3500 K	90	1935	2081	34	450	136
CL25171205P440E*9	15.3	4000 K	90	1964	2111	34	450	138
CL25171205P450E*9	15.3	5000 K	90	1978	2127	34	450	139
CL25171205P457E*9	15.3	5700 K	90	1992	2142	34	450	140

Notes for Table 5:

1. Nominal CCT as defined by ANSI C78.377-2015.
2. Products tested based on operation under DC(Direct current) with LED array mounted onto a heat sink with thermal interface material and T_j (junction temperature) = 85° C. Base on TYF test set up, values also depending on the thermal design and exposed environment to which the luminaire is subjected.
3. Typical performance values are provided as a reference only and are not a guarantee of performance.
4. TYF maintains a ±7% tolerance on flux measurements. ±3% tolerance on voltage measurements. ± 2 RA tolerance on Ra measurements.
5. Alternate drive currents are provided for reference only and are not a guarantee of performance.
6. $\Phi_{25^{\circ}\text{C}} = \Phi_{85^{\circ}\text{C}} / 0.895$

Performance Characteristics

Table 6: Electro-Optical Characteristics at Tj=85°C

Part Number	Typical Power (W)	Nominal CCT (K)	CRI	Minimum Pulsed Flux (lm)	Typical Pulsed Flux (lm)	Typical Voltage (V)	Nominal Current (mA)	Typical Efficacy (lm/W)
CL25171206P430E*7	18.4	3000 K	70	2772	2981	34	540	162
CL25171206P435E*7	18.4	3500 K	70	2823	3036	34	540	165
CL25171206P440E*7	18.4	4000 K	70	2858	3073	34	540	167
CL25171206P450E*7	18.4	5000 K	70	2926	3146	34	540	171
CL25171206P457E*7	18.4	5700 K	70	2943	3165	34	540	172
CL25171206P465E*7	18.4	6500 K	70	2926	3146	34	540	171
CL25171206P422E*8	18.4	2200 K	80	2310	2484	34	540	135
CL25171206P427E*8	18.4	2700 K	80	2481	2668	34	540	145
CL25171206P430E*8	18.4	3000 K	80	2601	2797	34	540	152
CL25171206P435E*8	18.4	3500 K	80	2635	2834	34	540	154
CL25171206P440E*8	18.4	4000 K	80	2669	2870	34	540	156
CL25171206P450E*8	18.4	5000 K	80	2721	2926	34	540	159
CL25171206P457E*8	18.4	5700 K	80	2738	2944	34	540	160
CL25171206P465E*8	18.4	6500 K	80	2721	2926	34	540	159
CL25171206P422E*9	18.4	2200 K	90	1968	2116	34	540	115
CL25171206P427E*9	18.4	2700 K	90	2122	2282	34	540	124
CL25171206P430E*9	18.4	3000 K	90	2225	2392	34	540	130
CL25171206P435E*9	18.4	3500 K	90	2276	2447	34	540	133
CL25171206P440E*9	18.4	4000 K	90	2310	2484	34	540	135
CL25171206P450E*9	18.4	5000 K	90	2327	2502	34	540	136
CL25171206P457E*9	18.4	5700 K	90	2344	2520	34	540	137

Notes for Table 6:

1. Nominal CCT as defined by ANSI C78.377-2015.
2. Products tested based on operation under DC(Direct current) with LED array mounted onto a heat sink with thermal interface material and Tj (junction temperature) = 85° C. Base on TYF test set up, values also depending on the thermal design and exposed environment to which the luminaire is subjected.
3. Typical performance values are provided as a reference only and are not a guarantee of performance.
4. TYF maintains a ±7% tolerance on flux measurements. ±3% tolerance on voltage measurements. ± 2 RA tolerance on Ra measurements.
5. Alternate drive currents are provided for reference only and are not a guarantee of performance.
6. $\Phi_{25^{\circ}\text{C}} = \Phi_{85^{\circ}\text{C}} / 0.895$

Performance Characteristics

Table 7: Electro-Optical Characteristics at Tj=85°C

Part Number	Typical Power (W)	Nominal CCT (K)	CRI	Minimum Pulsed Flux (lm)	Typical Pulsed Flux (lm)	Typical Voltage (V)	Nominal Current (mA)	Typical Efficacy (lm/W)
CL25171208P430E*7	24.5	3000 K	70	3646	3920	34	720	160
CL25171208P435E*7	24.5	3500 K	70	3714	3994	34	720	163
CL25171208P440E*7	24.5	4000 K	70	3760	4043	34	720	165
CL25171208P450E*7	24.5	5000 K	70	3805	4092	34	720	167
CL25171208P457E*7	24.5	5700 K	70	3851	4141	34	720	169
CL25171208P465E*7	24.5	6500 K	70	3805	4092	34	720	167
CL25171208P422E*8	24.5	2200 K	80	3030	3259	34	720	133
CL25171208P427E*8	24.5	2700 K	80	3258	3504	34	720	143
CL25171208P430E*8	24.5	3000 K	80	3418	3675	34	720	150
CL25171208P435E*8	24.5	3500 K	80	3463	3724	34	720	152
CL25171208P440E*8	24.5	4000 K	80	3509	3773	34	720	154
CL25171208P450E*8	24.5	5000 K	80	3577	3847	34	720	157
CL25171208P457E*8	24.5	5700 K	80	3599	3871	34	720	158
CL25171208P465E*8	24.5	6500 K	80	3577	3847	34	720	157
CL25171208P422E*9	24.5	2200 K	90	2597	2793	34	720	114
CL25171208P427E*9	24.5	2700 K	90	2780	2989	34	720	122
CL25171208P430E*9	24.5	3000 K	90	2916	3136	34	720	128
CL25171208P435E*9	24.5	3500 K	90	3008	3234	34	720	132
CL25171208P440E*9	24.5	4000 K	90	3030	3259	34	720	133
CL25171208P450E*9	24.5	5000 K	90	3053	3283	34	720	134
CL25171208P457E*9	24.5	5700 K	90	3075	3307	34	720	135

Notes for Table 7:

1. Nominal CCT as defined by ANSI C78.377-2015.
2. Products tested based on operation under DC(Direct current) with LED array mounted onto a heat sink with thermal interface material and Tj (junction temperature) = 85° C. Base on TYF test set up, values also depending on the thermal design and exposed environment to which the luminaire is subjected.
3. Typical performance values are provided as a reference only and are not a guarantee of performance.
4. TYF maintains a ±7% tolerance on flux measurements. ±3% tolerance on voltage measurements. ± 2 RA tolerance on Ra measurements.
5. Alternate drive currents are provided for reference only and are not a guarantee of performance.
6. Φ 25°C=Φ85°C/0.895

Performance Characteristics

Table 8: Electro-Optical Characteristics at Tj=85°C

Part Number	Typical Power (W)	Nominal CCT (K)	CRI	Minimum Pulsed Flux (lm)	Typical Pulsed Flux (lm)	Typical Voltage (V)	Nominal Current (mA)	Typical Efficacy (lm/W)
CL25171210P430E*7	30.6	3000 K	70	4468	4804	34	900	157
CL25171210P435E*7	30.6	3500 K	70	4553	4896	34	900	160
CL25171210P440E*7	30.6	4000 K	70	4639	4988	34	900	163
CL25171210P450E*7	30.6	5000 K	70	4696	5049	34	900	165
CL25171210P457E*7	30.6	5700 K	70	4724	5080	34	900	166
CL25171210P465E*7	30.6	6500 K	70	4696	5049	34	900	165
CL25171210P422E*8	30.6	2200 K	80	3785	4070	34	900	133
CL25171210P427E*8	30.6	2700 K	80	4013	4315	34	900	141
CL25171210P430E*8	30.6	3000 K	80	4183	4498	34	900	147
CL25171210P435E*8	30.6	3500 K	80	4240	4559	34	900	149
CL25171210P440E*8	30.6	4000 K	80	4297	4621	34	900	151
CL25171210P450E*8	30.6	5000 K	80	4326	4651	34	900	152
CL25171210P457E*8	30.6	5700 K	80	4354	4681	34	900	153
CL25171210P465E*8	30.6	6500 K	80	4326	4651	34	900	152
CL25171210P422E*9	30.6	2200 K	90	3187	3427	34	900	112
CL25171210P427E*9	30.6	2700 K	90	3415	3672	34	900	120
CL25171210P430E*9	30.6	3000 K	90	3586	3856	34	900	126
CL25171210P435E*9	30.6	3500 K	90	3643	3917	34	900	128
CL25171210P440E*9	30.6	4000 K	90	3671	3947	34	900	129
CL25171210P450E*9	30.6	5000 K	90	3700	3978	34	900	130
CL25171210P457E*9	30.6	5700 K	90	3728	4008	34	900	131

Notes for Table 8:

1. Nominal CCT as defined by ANSI C78.377-2015.
2. Products tested based on operation under DC(Direct current) with LED array mounted onto a heat sink with thermal interface material and Tj (junction temperature) = 85° C. Base on TYF test set up, values also depending on the thermal design and exposed environment to which the luminaire is subjected.
3. Typical performance values are provided as a reference only and are not a guarantee of performance.
4. TYF maintains a ±7% tolerance on flux measurements. ±3% tolerance on voltage measurements. ± 2 RA tolerance on Ra measurements.
5. Alternate drive currents are provided for reference only and are not a guarantee of performance.
6. Φ 25°C=Φ85°C/0.895

Performance Characteristics

Table 9: Electro-Optical Characteristics at Tj=85°C

Part Number	Typical Power (W)	Nominal CCT (K)	CRI	Minimum Pulsed Flux (lm)	Typical Pulsed Flux (lm)	Typical Voltage (V)	Nominal Current (mA)	Typical Efficacy (lm/W)
CL36241211P430E*7	33.7	3000 K	70	5140	5527	34	990	164
CL36241211P435E*7	33.7	3500 K	70	5203	5594	34	990	166
CL36241211P440E*7	33.7	4000 K	70	5297	5695	34	990	169
CL36241211P450E*7	33.7	5000 K	70	5359	5763	34	990	171
CL36241211P457E*7	33.7	5700 K	70	5391	5796	34	990	172
CL36241211P465E*7	33.7	6500 K	70	5359	5763	34	990	171
CL36241211P422E*8	33.7	2200 K	80	4294	4617	34	990	137
CL36241211P427E*8	33.7	2700 K	80	4607	4954	34	990	147
CL36241211P430E*8	33.7	3000 K	80	4795	5156	34	990	153
CL36241211P435E*8	33.7	3500 K	80	4858	5224	34	990	155
CL36241211P440E*8	33.7	4000 K	80	4921	5291	34	990	157
CL36241211P450E*8	33.7	5000 K	80	4983	5358	34	990	159
CL36241211P457E*8	33.7	5700 K	80	5014	5391	34	990	160
CL36241211P465E*8	33.7	6500 K	80	4983	5358	34	990	159
CL36241211P422E*9	33.7	2200 K	90	3730	4010	34	990	119
CL36241211P427E*9	33.7	2700 K	90	3980	4280	34	990	127
CL36241211P430E*9	33.7	3000 K	90	4137	4448	34	990	132
CL36241211P435E*9	33.7	3500 K	90	4231	4550	34	990	135
CL36241211P440E*9	33.7	4000 K	90	4294	4617	34	990	137
CL36241211P450E*9	33.7	5000 K	90	4325	4651	34	990	138
CL36241211P457E*9	33.7	5700 K	90	4356	4684	34	990	139

Notes for Table 9:

1. Nominal CCT as defined by ANSI C78.377-2015.
2. Products tested based on operation under DC(Direct current) with LED array mounted onto a heat sink with thermal interface material and Tj (junction temperature) = 85° C. Base on TYF test set up, values also depending on the thermal design and exposed environment to which the luminaire is subjected.
3. Typical performance values are provided as a reference only and are not a guarantee of performance.
4. TYF maintains a ±7% tolerance on flux measurements. ±3% tolerance on voltage measurements. ± 2 RA tolerance on Ra measurements.
5. Alternate drive currents are provided for reference only and are not a guarantee of performance.
6. $\Phi_{25^{\circ}\text{C}} = \Phi_{85^{\circ}\text{C}} / 0.895$

Performance Characteristics

Table 10: Electro-Optical Characteristics at Tj=85°C

Part Number	Typical Power (W)	Nominal CCT (K)	CRI	Minimum Pulsed Flux (lm)	Typical Pulsed Flux (lm)	Typical Voltage (V)	Nominal Current (mA)	Typical Efficacy (lm/W)
CL36241212P430E*7	36.7	3000 K	70	5597	6019	34	1080	164
CL36241212P435E*7	36.7	3500 K	70	5666	6092	34	1080	166
CL36241212P440E*7	36.7	4000 K	70	5768	6202	34	1080	169
CL36241212P450E*7	36.7	5000 K	70	5836	6276	34	1080	171
CL36241212P457E*7	36.7	5700 K	70	5871	6312	34	1080	172
CL36241212P465E*7	36.7	6500 K	70	5836	6276	34	1080	171
CL36241212P422E*8	36.7	2200 K	80	4676	5028	34	1080	137
CL36241212P427E*8	36.7	2700 K	80	5017	5395	34	1080	147
CL36241212P430E*8	36.7	3000 K	80	5222	5615	34	1080	153
CL36241212P435E*8	36.7	3500 K	80	5290	5689	34	1080	155
CL36241212P440E*8	36.7	4000 K	80	5359	5762	34	1080	157
CL36241212P450E*8	36.7	5000 K	80	5427	5835	34	1080	159
CL36241212P457E*8	36.7	5700 K	80	5461	5871	34	1080	160
CL36241212P465E*8	36.7	6500 K	80	5427	5835	34	1080	159
CL36241212P422E*9	36.7	2200 K	90	4062	4367	34	1080	119
CL36241212P427E*9	36.7	2700 K	90	4335	4661	34	1080	127
CL36241212P430E*9	36.7	3000 K	90	4505	4844	34	1080	132
CL36241212P435E*9	36.7	3500 K	90	4608	4955	34	1080	135
CL36241212P440E*9	36.7	4000 K	90	4676	5028	34	1080	137
CL36241212P450E*9	36.7	5000 K	90	4710	5065	34	1080	138
CL36241212P457E*9	36.7	5700 K	90	4744	5101	34	1080	139

Notes for Table 10:

1. Nominal CCT as defined by ANSI C78.377-2015.
2. Products tested based on operation under DC(Direct current) with LED array mounted onto a heat sink with thermal interface material and Tj (junction temperature) = 85° C. Base on TYF test set up, values also depending on the thermal design and exposed environment to which the luminaire is subjected.
3. Typical performance values are provided as a reference only and are not a guarantee of performance.
4. TYF maintains a ±7% tolerance on flux measurements. ±3% tolerance on voltage measurements. ± 2 RA tolerance on Ra measurements.
5. Alternate drive currents are provided for reference only and are not a guarantee of performance.
6. $\Phi_{25^{\circ}\text{C}} = \Phi_{85^{\circ}\text{C}} / 0.895$

Performance Characteristics

Table 11: Electro-Optical Characteristics at Tj=85°C

Part Number	Typical Power (W)	Nominal CCT (K)	CRI	Minimum Pulsed Flux (lm)	Typical Pulsed Flux (lm)	Typical Voltage (V)	Nominal Current (mA)	Typical Efficacy (lm/W)
CL36241216P430E*7	49.0	3000 K	70	7291	7840	34	1440	160
CL36241216P435E*7	49.0	3500 K	70	7428	7987	34	1440	163
CL36241216P440E*7	49.0	4000 K	70	7519	8085	34	1440	165
CL36241216P450E*7	49.0	5000 K	70	7610	8183	34	1440	167
CL36241216P457E*7	49.0	5700 K	70	7701	8281	34	1440	169
CL36241216P465E*7	49.0	6500 K	70	7610	8183	34	1440	167
CL36241216P422E*8	49.0	2200 K	80	6061	6517	34	1440	133
CL36241216P427E*8	49.0	2700 K	80	6517	7007	34	1440	143
CL36241216P430E*8	49.0	3000 K	80	6836	7350	34	1440	150
CL36241216P435E*8	49.0	3500 K	80	6927	7448	34	1440	152
CL36241216P440E*8	49.0	4000 K	80	7018	7546	34	1440	154
CL36241216P450E*8	49.0	5000 K	80	7154	7693	34	1440	157
CL36241216P457E*8	49.0	5700 K	80	7199	7742	34	1440	158
CL36241216P465E*8	49.0	6500 K	80	7154	7693	34	1440	157
CL36241216P422E*9	49.0	2200 K	90	5195	5586	34	1440	114
CL36241216P427E*9	49.0	2700 K	90	5560	5978	34	1440	122
CL36241216P430E*9	49.0	3000 K	90	5833	6272	34	1440	128
CL36241216P435E*9	49.0	3500 K	90	6015	6468	34	1440	132
CL36241216P440E*9	49.0	4000 K	90	6061	6517	34	1440	133
CL36241216P450E*9	49.0	5000 K	90	6106	6566	34	1440	134
CL36241216P457E*9	49.0	5700 K	90	6151	6615	34	1440	135

Notes for Table 11:

1. Nominal CCT as defined by ANSI C78.377-2015.
2. Products tested based on operation under DC(Direct current) with LED array mounted onto a heat sink with thermal interface material and Tj (junction temperature) = 85° C. Base on TYF test set up, values also depending on the thermal design and exposed environment to which the luminaire is subjected.
3. Typical performance values are provided as a reference only and are not a guarantee of performance.
4. TYF maintains a ±7% tolerance on flux measurements. ±3% tolerance on voltage measurements. ± 2 RA tolerance on Ra measurements.
5. Alternate drive currents are provided for reference only and are not a guarantee of performance.
6. $\Phi_{25^{\circ}\text{C}} = \Phi_{85^{\circ}\text{C}} / 0.895$

Performance Characteristics

Table 12: Electro-Optical Characteristics at Tj=85°C

Part Number	Typical Power (W)	Nominal CCT (K)	CRI	Minimum Pulsed Flux (lm)	Typical Pulsed Flux (lm)	Typical Voltage (V)	Nominal Current (mA)	Typical Efficacy (lm/W)
CL36241812P430E*7	55.3	3000 K	70	8229	8848	51.2	1080	160
CL36241812P435E*7	55.3	3500 K	70	8383	9014	51.2	1080	163
CL36241812P440E*7	55.3	4000 K	70	8486	9125	51.2	1080	165
CL36241812P450E*7	55.3	5000 K	70	8589	9235	51.2	1080	167
CL36241812P457E*7	55.3	5700 K	70	8692	9346	51.2	1080	169
CL36241812P465E*7	55.3	6500 K	70	8589	9235	51.2	1080	167
CL36241812P422E*8	55.3	2200 K	80	6840	7355	51.2	1080	133
CL36241812P427E*8	55.3	2700 K	80	7354	7908	51.2	1080	143
CL36241812P430E*8	55.3	3000 K	80	7714	8295	51.2	1080	150
CL36241812P435E*8	55.3	3500 K	80	7817	8406	51.2	1080	152
CL36241812P440E*8	55.3	4000 K	80	7920	8516	51.2	1080	154
CL36241812P450E*8	55.3	5000 K	80	8022	8625	51.2	1080	156
CL36241812P457E*8	55.3	5700 K	80	8074	8682	51.2	1080	157
CL36241812P465E*8	55.3	6500 K	80	8074	8682	51.2	1080	157
CL36241812P422E*9	55.3	2200 K	90	5863	6304	51.2	1080	114
CL36241812P427E*9	55.3	2700 K	90	6274	6747	51.2	1080	122
CL36241812P430E*9	55.3	3000 K	90	6583	7078	51.2	1080	128
CL36241812P435E*9	55.3	3500 K	90	6789	7300	51.2	1080	132
CL36241812P440E*9	55.3	4000 K	90	6840	7355	51.2	1080	133
CL36241812P450E*9	55.3	5000 K	90	6891	7410	51.2	1080	134
CL36241812P457E*9	55.3	5700 K	90	6942	7465	51.2	1080	135

Notes for Table 12:

1. Nominal CCT as defined by ANSI C78.377-2015.
2. Products tested based on operation under DC(Direct current) with LED array mounted onto a heat sink with thermal interface material and Tj (junction temperature) = 85° C. Base on TYF test set up, values also depending on the thermal design and exposed environment to which the luminaire is subjected.
3. Typical performance values are provided as a reference only and are not a guarantee of performance.
4. TYF maintains a ±7% tolerance on flux measurements. ±3% tolerance on voltage measurements. ± 2 RA tolerance on Ra measurements.
5. Alternate drive currents are provided for reference only and are not a guarantee of performance.
6. $\Phi_{25^{\circ}\text{C}} = \Phi_{85^{\circ}\text{C}} / 0.895$

Performance Characteristics

Table 13: Electro-Optical Characteristics at Tj=85°C

Part Number	Typical Power (W)	Nominal CCT (K)	CRI	Minimum Pulsed Flux (lm)	Typical Pulsed Flux (lm)	Typical Voltage (V)	Nominal Current (mA)	Typical Efficacy (lm/W)
CL36241818P430E*7	82.9	3000 K	70	11796	12684	51.2	1620	153
CL36241818P435E*7	82.9	3500 K	70	11950	12850	51.2	1620	155
CL36241818P440E*7	82.9	4000 K	70	12104	13015	51.2	1620	157
CL36241818P450E*7	82.9	5000 K	70	12181	13098	51.2	1620	158
CL36241818P457E*7	82.9	5700 K	70	12336	13264	51.2	1620	160
CL36241818P465E*7	82.9	6500 K	70	12181	13098	51.2	1620	158
CL36241818P422E*8	82.9	2200 K	80	9637	10363	51.2	1620	125
CL36241818P427E*8	82.9	2700 K	80	10408	11192	51.2	1620	135
CL36241818P430E*8	82.9	3000 K	80	10948	11772	51.2	1620	142
CL36241818P435E*8	82.9	3500 K	80	11102	11938	51.2	1620	144
CL36241818P440E*8	82.9	4000 K	80	11256	12103	51.2	1620	146
CL36241818P450E*8	82.9	5000 K	80	11410	12269	51.2	1620	148
CL36241818P457E*8	82.9	5700 K	80	11487	12352	51.2	1620	149
CL36241818P465E*8	82.9	6500 K	80	11410	12269	51.2	1620	148
CL36241818P422E*9	82.9	2200 K	90	8172	8787	51.2	1620	106
CL36241818P427E*9	82.9	2700 K	90	8943	9616	51.2	1620	116
CL36241818P430E*9	82.9	3000 K	90	9252	9948	51.2	1620	120
CL36241818P435E*9	82.9	3500 K	90	9483	10197	51.2	1620	123
CL36241818P440E*9	82.9	4000 K	90	9637	10363	51.2	1620	125
CL36241818P450E*9	82.9	5000 K	90	9714	10445	51.2	1620	126
CL36241818P457E*9	82.9	5700 K	90	9791	10528	51.2	1620	127

Notes for Table 13:

1. Nominal CCT as defined by ANSI C78.377-2015.
2. Products tested based on operation under DC(Direct current) with LED array mounted onto a heat sink with thermal interface material and Tj (junction temperature) = 85° C. Base on TYF test set up, values also depending on the thermal design and exposed environment to which the luminaire is subjected.
3. Typical performance values are provided as a reference only and are not a guarantee of performance.
4. TYF maintains a ±7% tolerance on flux measurements. ±3% tolerance on voltage measurements. ± 2 RA tolerance on Ra measurements.
5. Alternate drive currents are provided for reference only and are not a guarantee of performance.
6. $\Phi_{25^{\circ}\text{C}} = \Phi_{85^{\circ}\text{C}} / 0.895$

Performance Characteristics

Table 14: Electro-Optical Characteristics at Tj=85°C

Part Number	Typical Power (W)	Nominal CCT (K)	CRI	Minimum Pulsed Flux (lm)	Typical Pulsed Flux (lm)	Typical Voltage (V)	Nominal Current (mA)	Typical Efficacy (lm/W)
CL54351818P430E*7	82.9	3000 K	70	12027	12932	51.2	1620	156
CL54351818P435E*7	82.9	3500 K	70	12181	13098	51.2	1620	158
CL54351818P440E*7	82.9	4000 K	70	12258	13181	51.2	1620	159
CL54351818P450E*7	82.9	5000 K	70	12413	13347	51.2	1620	161
CL54351818P457E*7	82.9	5700 K	70	12490	13430	51.2	1620	162
CL54351818P465E*7	82.9	6500 K	70	12413	13347	51.2	1620	161
CL54351818P422E*8	82.9	2200 K	80	10100	10860	51.2	1620	131
CL54351818P427E*8	82.9	2700 K	80	10948	11772	51.2	1620	142
CL54351818P430E*8	82.9	3000 K	80	11256	12103	51.2	1620	146
CL54351818P435E*8	82.9	3500 K	80	11410	12269	51.2	1620	148
CL54351818P440E*8	82.9	4000 K	80	11487	12352	51.2	1620	149
CL54351818P450E*8	82.9	5000 K	80	11642	12518	51.2	1620	151
CL54351818P457E*8	82.9	5700 K	80	11796	12684	51.2	1620	153
CL54351818P465E*8	82.9	6500 K	80	11642	12518	51.2	1620	151
CL54351818P422E*9	82.9	2200 K	90	8943	9616	51.2	1620	116
CL54351818P427E*9	82.9	2700 K	90	9791	10528	51.2	1620	127
CL54351818P430E*9	82.9	3000 K	90	10023	10777	51.2	1620	130
CL54351818P435E*9	82.9	3500 K	90	10177	10943	51.2	1620	132
CL54351818P440E*9	82.9	4000 K	90	10254	11026	51.2	1620	133
CL54351818P450E*9	82.9	5000 K	90	10408	11192	51.2	1620	135
CL54351818P457E*9	82.9	5700 K	90	10485	11275	51.2	1620	136

Notes for Table 14:

1. Nominal CCT as defined by ANSI C78.377-2015.
2. Products tested based on operation under DC(Direct current) with LED array mounted onto a heat sink with thermal interface material and Tj (junction temperature) = 85° C. Base on TYF test set up, values also depending on the thermal design and exposed environment to which the luminaire is subjected.
3. Typical performance values are provided as a reference only and are not a guarantee of performance.
4. TYF maintains a ±7% tolerance on flux measurements. ±3% tolerance on voltage measurements. ± 2 RA tolerance on Ra measurements.
5. Alternate drive currents are provided for reference only and are not a guarantee of performance.
6. Φ 25°C=Φ85°C/0.895

Performance Characteristics

Table 15: Electro-Optical Characteristics at Tj=85°C

Part Number	Typical Power (W)	Nominal CCT (K)	CRI	Minimum Pulsed Flux (lm)	Typical Pulsed Flux (lm)	Typical Voltage (V)	Nominal Current (mA)	Typical Efficacy (lm/W)
CL54351825P430E*7	115.2	3000 K	70	12336	13264	51.2	2250	160
CL54351825P435E*7	115.2	3500 K	70	12490	13430	51.2	2250	162
CL54351825P440E*7	115.2	4000 K	70	12567	13513	51.2	2250	163
CL54351825P450E*7	115.2	5000 K	70	12721	13679	51.2	2250	165
CL54351825P457E*7	115.2	5700 K	70	12798	13761	51.2	2250	166
CL54351825P465E*7	115.2	6500 K	70	12721	13679	51.2	2250	165
CL54351825P422E*8	115.2	2200 K	80	10485	11274	51.2	2250	136
CL54351825P427E*8	115.2	2700 K	80	11256	12103	51.2	2250	146
CL54351825P430E*8	115.2	3000 K	80	11565	12435	51.2	2250	150
CL54351825P435E*8	115.2	3500 K	80	11719	12601	51.2	2250	152
CL54351825P440E*8	115.2	4000 K	80	11950	12850	51.2	2250	155
CL54351825P450E*8	115.2	5000 K	80	12027	12932	51.2	2250	156
CL54351825P457E*8	115.2	5700 K	80	12181	13098	51.2	2250	158
CL54351825P465E*8	115.2	6500 K	80	12027	12932	51.2	2250	156
CL54351825P422E*9	115.2	2200 K	90	9329	10031	51.2	2250	121
CL54351825P427E*9	115.2	2700 K	90	10100	10860	51.2	2250	131
CL54351825P430E*9	115.2	3000 K	90	10408	11192	51.2	2250	135
CL54351825P435E*9	115.2	3500 K	90	10562	11357	51.2	2250	137
CL54351825P440E*9	115.2	4000 K	90	10639	11440	51.2	2250	138
CL54351825P450E*9	115.2	5000 K	90	10794	11606	51.2	2250	140
CL54351825P457E*9	115.2	5700 K	90	10871	11689	51.2	2250	141

Notes for Table 15:

- Nominal CCT as defined by ANSI C78.377-2015.
- Products tested based on operation under DC(Direct current) with LED array mounted onto a heat sink with thermal interface material and Tj (junction temperature) = 85° C. Base on TYF test set up, values also depending on the thermal design and exposed environment to which the luminaire is subjected.
- Typical performance values are provided as a reference only and are not a guarantee of performance.
- TYF maintains a ±7% tolerance on flux measurements. ±3% tolerance on voltage measurements. ± 2 RA tolerance on Ra measurements.
- Alternate drive currents are provided for reference only and are not a guarantee of performance.
- $\Phi_{25^{\circ}\text{C}} = \Phi_{85^{\circ}\text{C}} / 0.895$

Performance Characteristics

2.2 Electrical Characteristics

Table 16: Electrical Characteristics

Part Number	Drive Current (mA)	Forward Voltage Pulsed, T _j = 85°C (V)			Typical Coefficient Of Forward Voltage $\Delta V_f / \Delta T_j$ (mV/°C)	Typical Thermal Resistance Junction to Case R _{j-c} (°C/W)
		Minimum	Typical	Maximum		
CL13111201P4	90	33.6	34	40.8	-16	2.73
CL13111202P4	180	33.6	34	40.8	-16	1.57
CL13111203P4	270	33.6	34	40.8	-16	1.05
CL13111204P4	360	33.6	34	40.8	-16	0.90
CL25171205P4	450	33.6	34	40.8	-16	0.72
CL25171206P4	540	33.6	34	40.8	-16	0.64
CL25171208P4	720	33.6	34	40.8	-16	0.50
CL25171210P4	900	33.6	34	40.8	-16	0.42
CL36241211P4	990	33.6	34	40.8	-16	0.38
CL36241212P4	1080	33.6	34	40.8	-16	0.34
CL36241216P4	1440	33.6	34	40.8	-16	0.27
CL36241812P4	1080	50.4	51.2	61.2	-16	0.25
CL36241818P4	1620	50.4	51.2	61.2	-16	0.18
CL54351818P4	1620	50.4	51.2	61.2	-16	0.17
CL54351825P4	2250	50.4	51.2	61.2	-16	0.14

Notes for Table 16:

1. Products tested based on operation under DC(Direct current) with LED array mounted onto a heat sink with thermal interface material and T_j (junction temperature) = 85° C.
2. Voltage minimum and maximum are provided for reference only and are not a guarantee of performance.
3. TYF maintains a tester tolerance of ± 0.10V on forward voltage measurements.
4. Typical coefficient of forward voltage tolerance is ± 0.1mV for nominal current.
5. Thermal resistance values are based from test data of a 3000K 80 CRI product.
6. Thermal resistance value was calculated using total electrical input power; optical power was not subtracted from input power. The thermal interface material used during testing is not included in the thermal resistance value.
7. Vf min hot and max cold values are provided as reference only and are not guaranteed by test. These values are provided to aid in driver design and selection over the operating range of the product.

2.3 Color Binning Information

Figure 1: Graph of Test Bins in xy Color Space (Pulsed Test Conditions, T_c = 25°C)

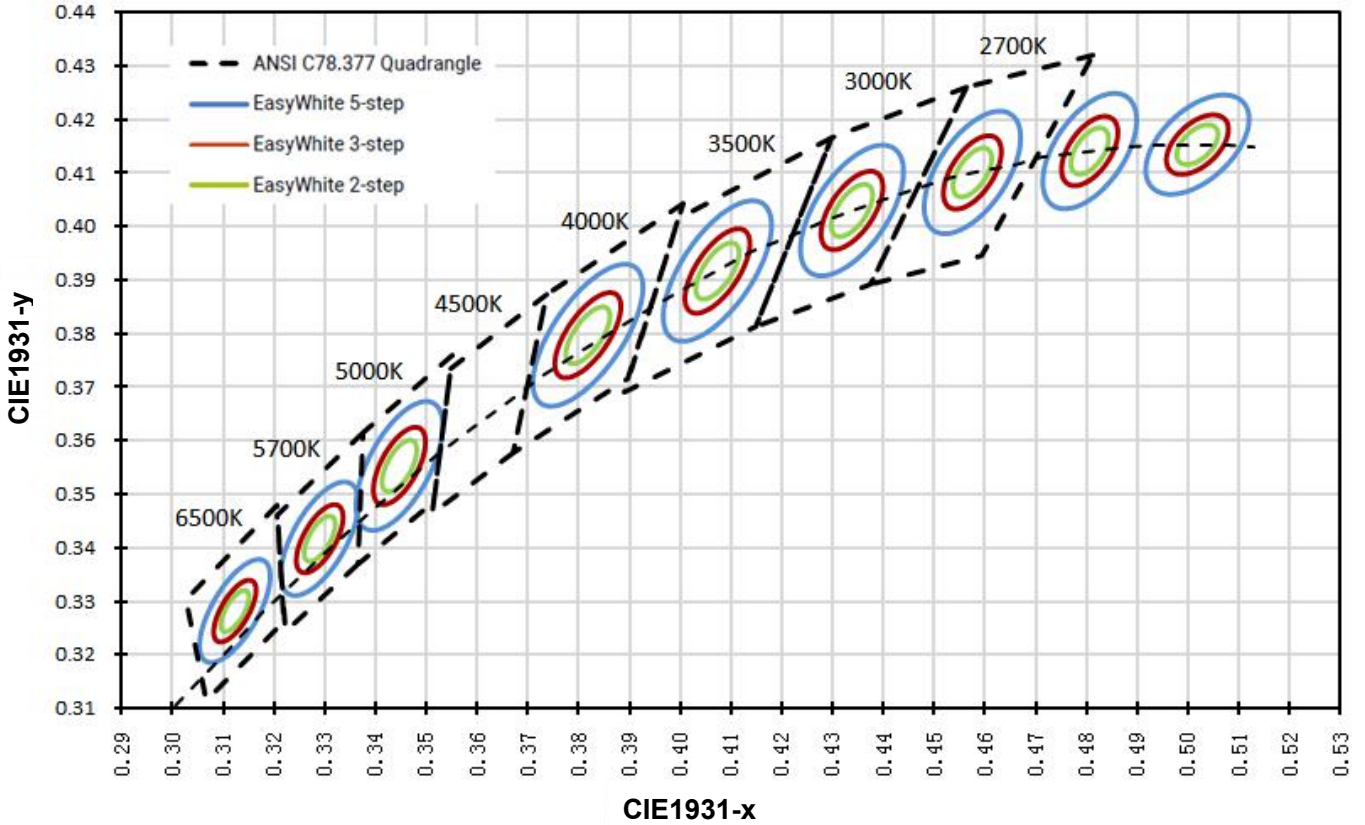

Table 17: 2-Step to 5-step MacAdam ellipse color bin definitions for TYF CoB Core Range

Nominal CCT	Center Point		MAJOR AXIS (a , b)			Ellipse Rotation Angel, θ
	X	Y	2-Step	3-Step	5-Step	
2200K	0.5018	0.4153	(0.0048 , 0.0027)	(0.0072, 0.0041)	(0.0120, 0.0067)	39.9
2500K	0.4806	0.4141	(0.0050, 0.0027)	(0.0076, 0.0041)	(0.0126, 0.0068)	53.1
2700K	0.4575	0.4101	(0.0053, 0.0027)	(0.0080, 0.0041)	(0.0133, 0.0068)	54.1
3000K	0.4338	0.4030	(0.0057, 0.0028)	(0.0086, 0.0042)	(0.0142, 0.0069)	53.7
3500K	0.4073	0.3917	(0.0062, 0.0028)	(0.0093, 0.0041)	(0.0155, 0.0069)	54.0
4000K	0.3818	0.3797	(0.0063, 0.0027)	(0.0093, 0.0042)	(0.0157, 0.0068)	53.4
5000K	0.3447	0.3553	(0.0054, 0.0024)	(0.0081, 0.0035)	(0.0135, 0.0059)	59.8
5700K	0.3290	0.3417	(0.0048, 0.0021)	(0.0072, 0.0032)	(0.0119, 0.0052)	58.8
6500K	0.3123	0.3282	(0.0044, 0.0018)	(0.0066, 0.0027)	(0.0110, 0.0045)	58.1

Note for Table 17:

TYF maintains a tolerance of ±0.005 on x and y coordinates in the CIE 1931 color space.

2.4 Absolute Maximum Ratings

Table 18: **Maximum Ratings**

Parameter	Maximum Rating
LED Junction Temperature (T_j)	125
Storage Temperature	-35 ~ +120
Operating Temperature	-30 ~ +105
Soldering Temperature	350°C/3-5S
Electrostatic Discharge (HBM)	2000V
	Single chip (Per parallel) Limit Value
Maximum Drive Current	250mA
Maximum Peak Pulsed Drive Current	300mA
Maximum Reverse Voltage	TYF LEDs are not designed to be driven in reverse bias

Notes for Table 18:

1. Driven the arrays at higher currents however lumen maintenance may be reduced.
2. Proper current derating must be observed to maintain junction temperature below the maximum
3. Pulsed operation with a peak drive current equal to the stated peak pulsed forward current is acceptable if the pulse on-time is $\leq 1\text{ms}$ per cycle and the duty cycle is $\leq 10\%$
4. Light emitting diodes are not designed to be driven in reverse voltage and will not produce light under this condition. Maximum rating provided for reference only.

Color Binning Information

Performance Curves

3.1 Characteristic Curves

Figure 2: Relative Luminous Flux Vs. Forward Current

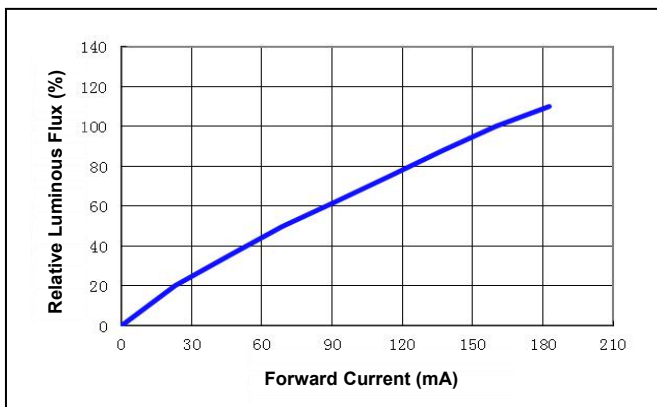

Figure 3: Forward Current vs. Forward Voltage

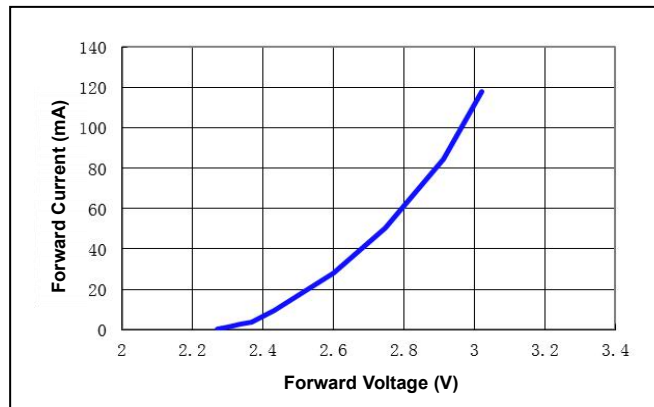

Figure 4: Forward Voltage Vs. Junction Temperature

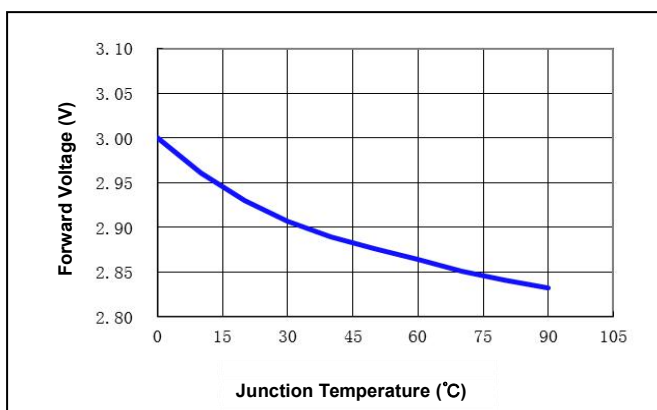
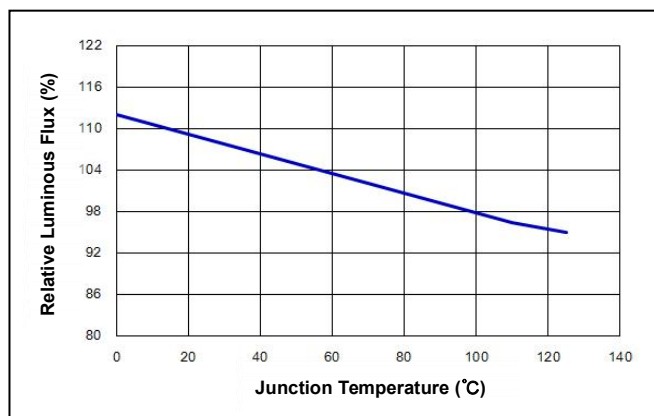

Figure 5: Relative Luminous Flux vs. Junction Temperature



Notes for Figures 2-5:

1. Figures for single LED chip
2. TYF does not recommend driving our LED arrays at low currents. Doing so may produce unpredictable results.
2. Products tested based on operation under DC(Direct current) with LED array mounted onto a heat sink with thermal interface material and T_j (junction temperature) = 85 ° C. Base on TYF test set up, values also depending on the thermal design and exposed environment to which the luminaire is subjected.

3.2 Optical Curves

Figure 6: Typical Spatial Radiation Pattern

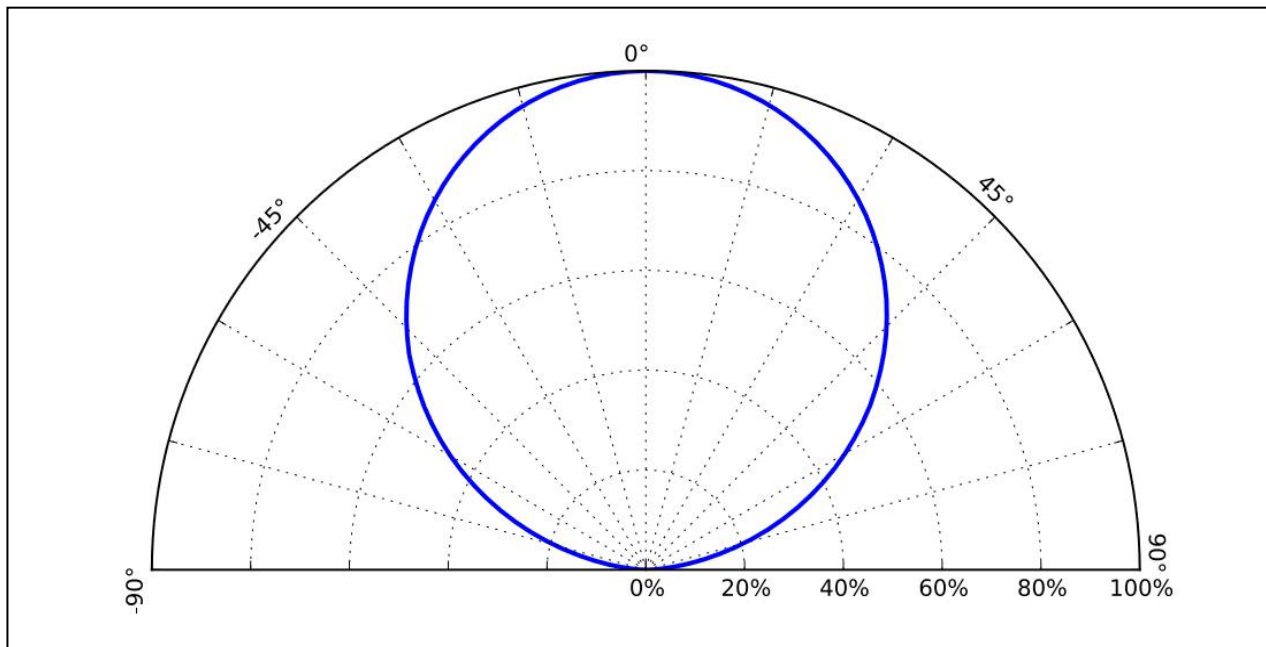
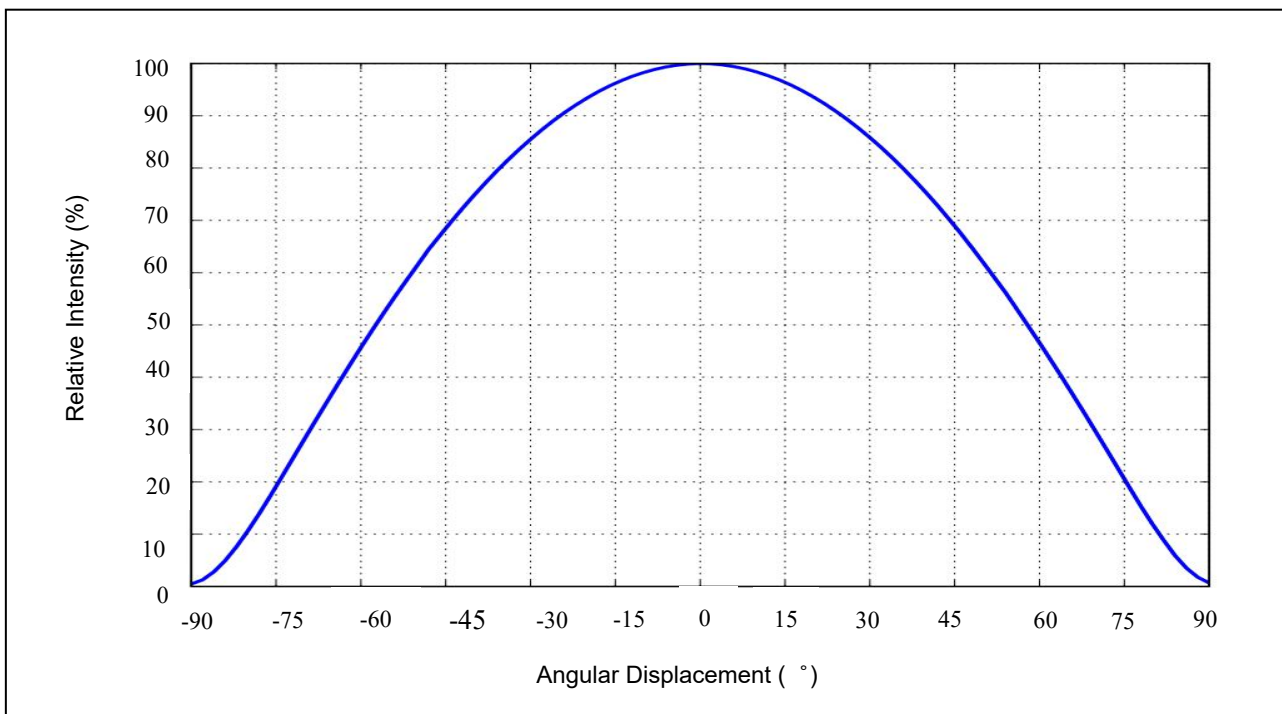

Figure 7: Typical Polar Radiation Pattern



- 1. Typical viewing angle is 120°.
- 2. The viewing angle is defined as the off axis angle from the center line where intensity is 1/2 of the peak value.

3.3 The Relative Spectral Distribution Graph

Figure 8: Typical Color Spectrum for 70CRI

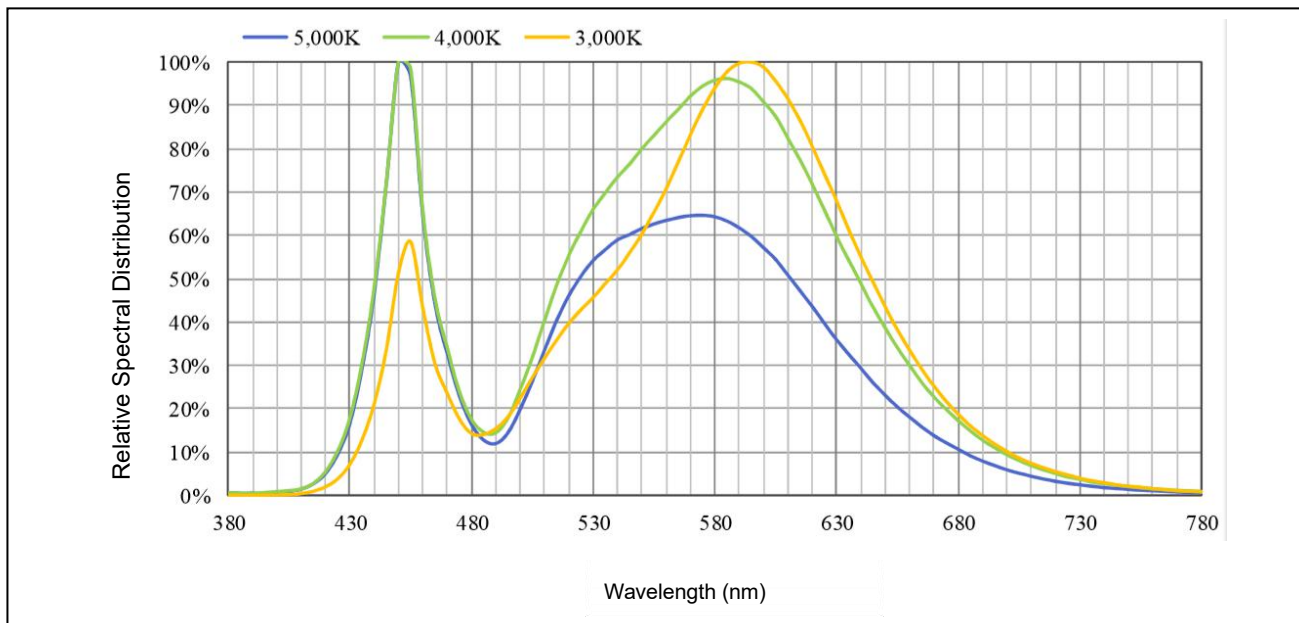

Note for Figure 8:

1. Color spectra measured at nominal current for $T_j = 25^\circ\text{C}$.
2. Color spectra shown is 3000K, 4000K, 5000K and 70 CRI.

Figure 9: Typical Color Spectrum for 80CRI

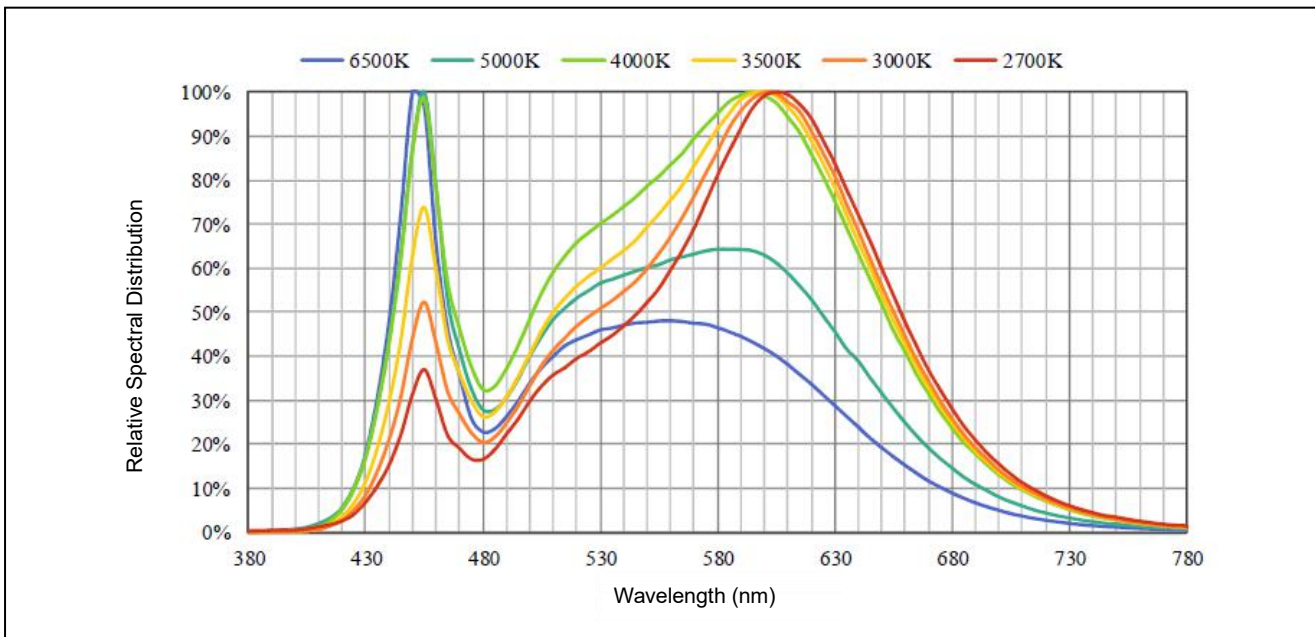

Note for Figure 9:

1. Color spectra measured at nominal current for $T_j = 25^\circ\text{C}$.
2. Color spectra shown is 2700K, 3000K, 3500K, 4000K, 5000K, 6500K and 80 CRI.

Performance Curves

Figure 10: Typical Color Spectrum for 90CRI

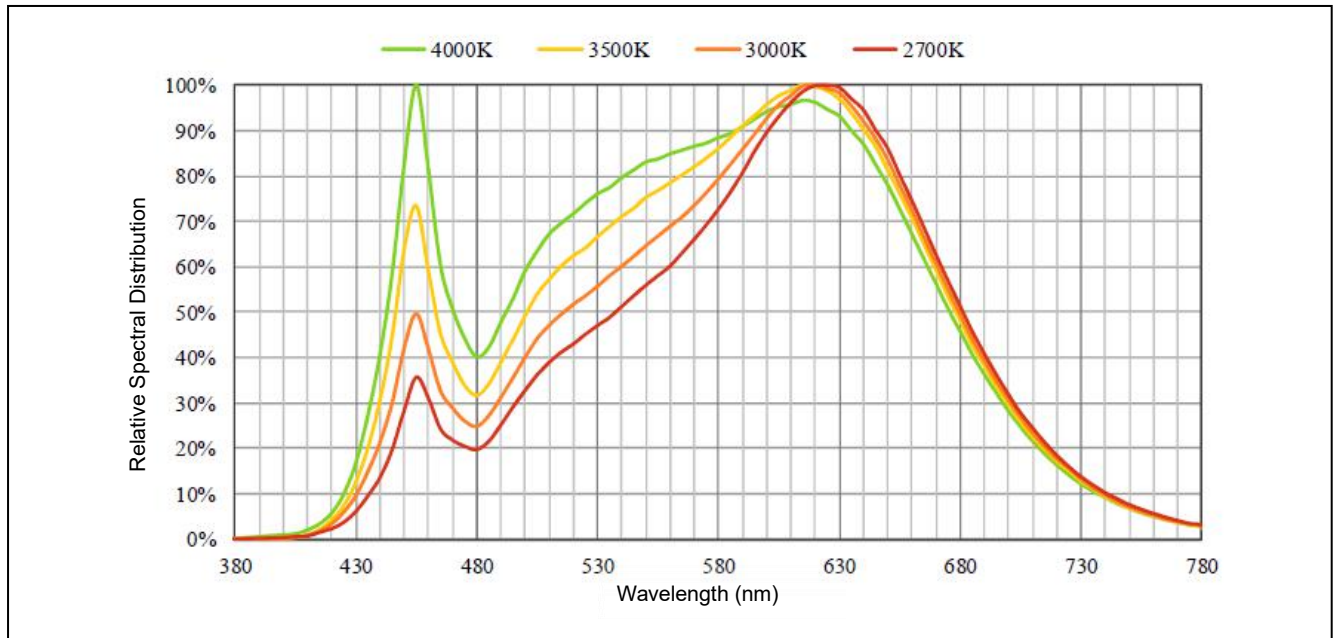

Note for Figure 10:

1. Color spectra measured at nominal current for $T_j = 25^\circ\text{C}$.
2. Color spectra shown is 2700K 、3000K、3500K、4000K and 90 CRI.

Reliability Test

Table 19: Reliability Test Items And Conditions

Test Items	Ref. Standard	Test Conditions	Sample Quantity	Failure Quantity
Thermal Shock	JESD22-A106	-40°C(15min) ~ 100°C(15min), 200 cycles	22	0
High Temperature Storage	JESD22-A103	Ta=120°C, 1000h	22	0
Low Temperature Storage	JESD22-A119	Ta=-40°C, 1000h	22	0
High Temperature High Humidity Life Test	JESD22-A101	Ta=85°C, RH>=85%, 1000h	22	0
High-Temperature Life Test	JESD22 -A108	Ta=105°C, IF=90mA@1 serie 1000h	22	0
Low-Temperature Life Test	JESD22 -A108	Ta=-40°C, IF=90mA@1 serie 1000h	22	0

Packaging and Labeling

Figure 11: Product Packing and Labeling

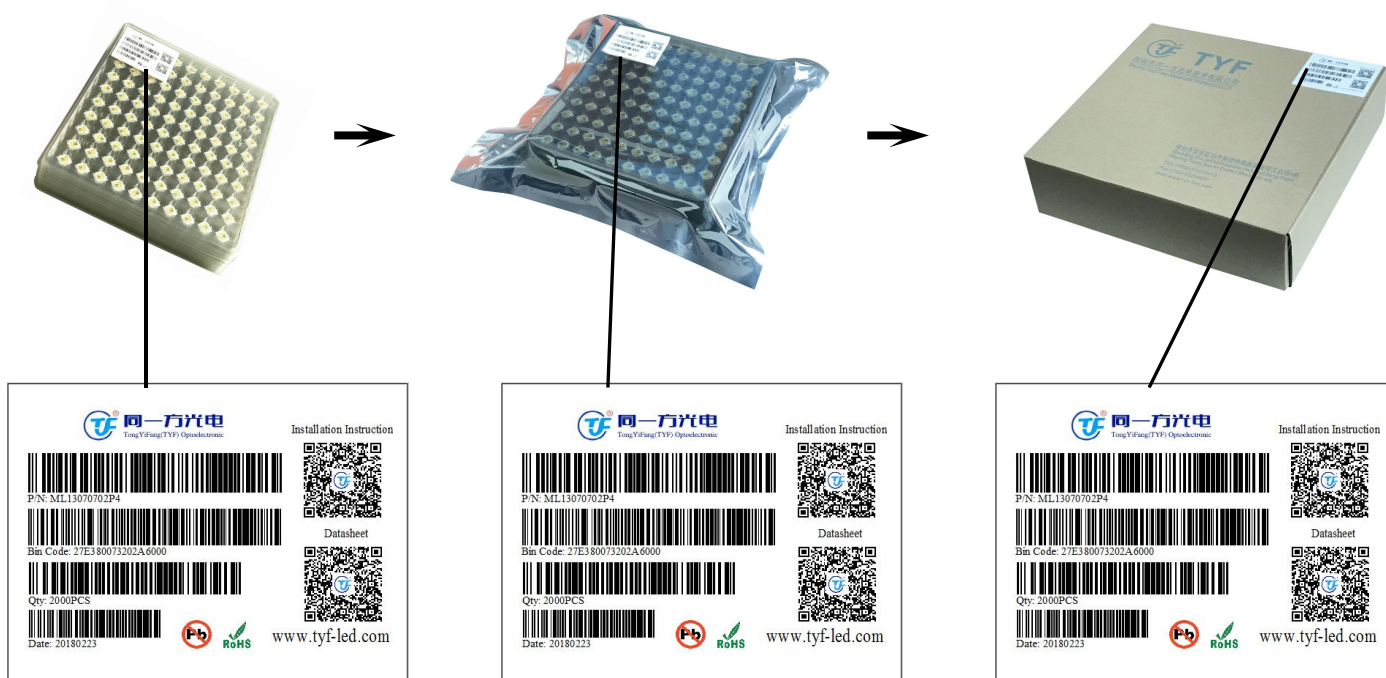

Notes for Figure 11:

1. Each tray holds 16 to 100pcs CoBs.
2. The top tray is to be labeled as shown above.

Figure 12: Product Labeling

TYF CoB has a product label outside of the plastic box. Besides the external label, TYF CoB light source has laser tag on the back to help the product identification

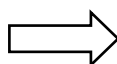
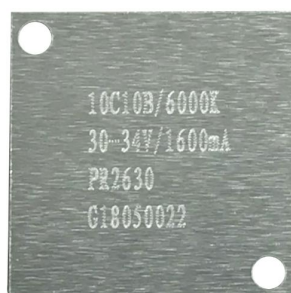

- Series and Parallels / CCT
- VF / Test Current
- Chip Brand and Size
- Production Number

Precautions

CAUTION

RECOMMENDED SOLDERING CONDITION

For manual soldering. Please use lead-free soldering and the soldering shall be implemented using a soldering bit at a temperature lower than 350C, and shall be finished within 3.5 seconds for one land. No external force shall be applied to resin part while soldering is implemented. Next process of soldering should be carried out after the product has return to ambient temperature.

CAUTION: TEMPERATURE CONTROL

Suggested Temperature on Tc	Suggested Temperature on the center of Emitting diameter:
$T_c = T_{J-c} - (R_{j-c} * P_i)$ $T_{J-c} \leq 125^\circ\text{C}$	Warm White LED <130°C Natural White LED <115°C Cool White LED <110°C

CAUTION: RISK OF STATIC ELECTRICITY

Handling of TYF LED array needs countermeasures against static electricity because this is a semiconductor product. Please take adequate measures to prevent any static electricity being produced such as the wearing of a wristband or anti-static gloves when handling this product. Every manufacturing facility in regard to the product (plant, equipment, machine, carrier machine and conveyance unit) should be connected to ground and please avoid the product to be electric-charged. ESD sensitivity of this product is 2000V (HBM, based on JEITA ED-4701/304). After assembling the LEDs into your final product(s), it is recommended to check whether the assembled LEDs are damaged by static electricity (electrical leak phenomenon) or not.

CAUTION: CHEMICAL EXPOSURE HAZARD

Exposure to some chemicals commonly used in luminaire manufacturing and assembly can cause damage to the LED array. Please consult TYF Installation Instruction for additional information.

CONTACT WITH LIGHT EMITTING SURFACE (LES)

Avoid any contact with the LES. Do not touch the LES of the LED array or apply stress to the LES(yellow phosphor resin area). Contact may cause damage to the LED array. Optics and reflectors must not be mounted in contact with the LES (yellow phosphor resin area). Optical devices may be mounted on the top surface of the plastic housing of the TYF LED array. Use the mechanical features of the LED array housing, edges and/or mounting holes to locate and secure optical devices as needed.

EYE SAFETY

Eye safety classification for the use of TYF LED arrays is in accordance with specification IEC/TR 62778: Application of IEC 62471 for the assessment of blue light hazard to light sources and luminaires. We classify TYF LED at 4000K qualified RG2 , Ethr= 1847.5 lx. At 5000K qualified RG2. Ethr= 1315.8 lx. At 6500K qualified RG2, Ethr= 1124.5 lx.

Please consult TYF Installation Instruction for additional information.

About TYF

TongYiFang(TYF) is one of the leading experts manufacturer of high power LED chip in China. We committed to providing environmentally friendly products to the solid-state lighting mark. TYF LEDs are compliant to the European Union directives on the restriction of hazardous substances in electronic equipment, namely the RoHS Directive 2011/65/EU and REACH Regulation (EC) 1907/2006. Let's make light excellent.

For more information about TYF(TongYiFang) please visit:
www.tyf-led.com



Building No.4, Xinlian River Industrial Park, Shajing Street,
Bao'an District, Shenzhen 518104 China
Tel: +86-755-29432329
Fax : +86-755-29451939
www.tyf-led.com

© 2018 TongYiFang (TYF), Inc. All rights reserved 2018.
TYF CL CoB Series Product Data Sheet Rev.6/19/2018

X-ON Electronics

Largest Supplier of Electrical and Electronic Components

Click to view similar products for [High Power LEDs - White](#) category:

Click to view products by [TONGYIFANG](#) manufacturer:

Other Similar products are found below :

[G42180-08](#) [B42180-08](#) [STW8Q2PA-R5-HA](#) [SZ5-M1-W0-00-V3/W2-AA](#) [LTPL-P00DWS57](#) [LZP-D0WW00-0000](#) [CLM-9-30-90-36-AC32-F4-3](#)
[SZ5-M1-WW-C8-V1/V3-FA](#) [XHP50B-00-0000-0D0HJ240H](#) [BXRC-27E2000-D-73](#) [BXRC-27G2000-D-73](#) [BXRC-30E1000-D-73](#) [BXRC-30G2000-D-73](#) [BXRC-40E1000-D-73](#) [BXRE-30G2000-B-73](#) [BXRE-30G2000-C-73](#) [BXRE-50C2001-C-74](#) [CXM-22-27-80-54-AC30-F4-3](#) [XHP50B-00-0000-0D0UH245G](#) [XHP50B-00-0000-0D0UG227H](#) [XHP50B-00-0000-0D0HJ245G](#) [MP-5050-8100-27-80](#) [MP-5050-6100-65-80](#) [MP-5050-6100-50-80](#) [MP-5050-6100-40-80](#) [MP-5050-6100-30-80](#) [MP-3020-3100-65-80](#) [MP-3020-3100-40-90](#) [MP-3014-1100-40-80](#) [MP-3014-1100-35-80](#) [MP-3014-1100-30-80](#) [MP-3014-1100-27-80](#) [CXM-22-30-80-54-AC30-F4-3](#) [MP-3014-1100-57-70](#) [LTW-2835SZK57](#) [BXEM-50C0000-0-000](#) [WW-WNA30TS-U1\(M1\)](#) [KW CSLPM2.CC-8L8M-4L8N](#) [KW CSLPM2.CC-8L8M-4O9Q](#) [KW DPLS32.SB-6H6J-E5P7-EG-Z264](#) [L1V1-507003V500000](#)
[CXM-22-35-80-36-AC10-F3-3](#) [KW3 CGLNM1.TG-Z6QF6-EBVFFCBB46-DFGA](#) [GWCS8PM1.PM-LSLU-A232-1](#) [JB5630AWT-H-H65EA0000-NZ000001](#) [XHP50B-00-0000-0D0UG430H](#) [CXM-22-35-90-54-AC40-F5-3](#) [CXM-22-35-80-54-AC40-F5-3](#) [OSM51206E1N-0.8T](#) [OSM53535C1A-150MA](#)