

Diode type D95 are of modern design with pressure contacts, high alumina ceramic insulator and cold-welding encapsulation. Designed for use in power rectifying circuits and equipment under normal operating conditions.

KEY PARAMETERS

U_{RRM}	up to 2400 V
$I_{F(AV)}$	2500 A
I_{FSM}	31000 A

FEATURES

- all diffused design
- high current capabilities
- high surge current capabilities
- high rated voltages
- low thermal impedance
- tested according to IEC standards
- compact size and small weight

APPLICATION

- High Voltage Power Supplies
- Motor Control
- Battery Chargers
- Free Wheeling Diode
- Resistance Welding
- Medium traction applications

Designed for use in high power industrial and commercial electronic circuits and equipment where high currents are encountered and high reliability is essential. Low forward voltages let minimize energy loss.

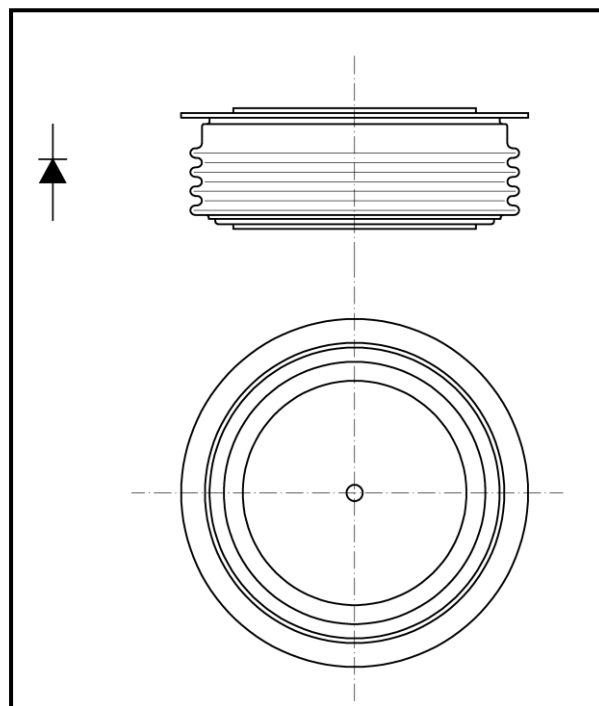

Outline type code: JEDEC DO-200AC
See Package Details for further information

ORDERING INFORMATION

When ordering please refer to device code builder presented below.
Please use the complete part number when ordering, quote or in any future correspondence relating to your order.

D95-2500-

voltage class (hundreds of volts)

D95-2500

Diode



Zakłady Elektronowe
LAMINA S.A.

KKD952500, November 2004 version

ELECTRICAL PARAMETERS

Voltage ratings

Voltage class	U_{RRM}	U_{RSM}	I_{RRM}
	V	V	mA
16	1600	1700	100
18	1800	1900	
20	2000	2100	
22	2200	2300	
24	2400	2500	

Electrical properties

Parameter	Unit	Test conditions	Value
Average forward current @ case temperature	$I_{F(AV)}$	A	2500
	T_c	°C	85
RMS forward current	$I_{F(RMS)}$	A	3900
Surge current	I_{FSM}	A	$T_j=175^\circ\text{C}$, $U_R=0,8U_{RRM}$, $t_p=10\text{ms}$
I^2t – value	I^2t	kA^2s	4800
Forward voltage drop max.	U_{FM}	V	$T_j=25^\circ\text{C}$, $I_{FM}=1500\text{A}$
Threshold voltage	$U_{F(T0)}$	V	0,62
Slope resistance	r_F	$\text{m}\Omega$	0,164
Typical reverse recovery charge	Q_r	μC	$T_j=25^\circ\text{C}$, $I_{FM}=1500\text{A}$, $di_R/dt=25\text{A}/\mu\text{s}$

Thermal properties

Parameter	Unit	Test conditions	Value
Thermal resistance, junction to case	R_{thJC}	°C/W	two sided, DC
Thermal resistance, case to heatsink	R_{thCS}	°C/W	two sided
Operating junction temperature	$T_{jmin} \dots T_{jmax}$	°C	-40...+175
Storage temperature	T_{stg}	°C	-40...+175

Mechanical properties

Parameter	Unit	Value
Clamping force	F_M	kN
Weight	m	g

Zakłady Elektronowe LAMINA S.A.
Puławska 34
PL-05-500 Piaseczno
POLAND

Tel.: +48-22-7572731
Tel.: +48-22-3989409
Fax.: +48-22-3989407
e-mail: sekretariat@lamina.com.pl
www.lamina.com.pl

D95-2500

Diode

KKD952500, November 2004 version

Package details

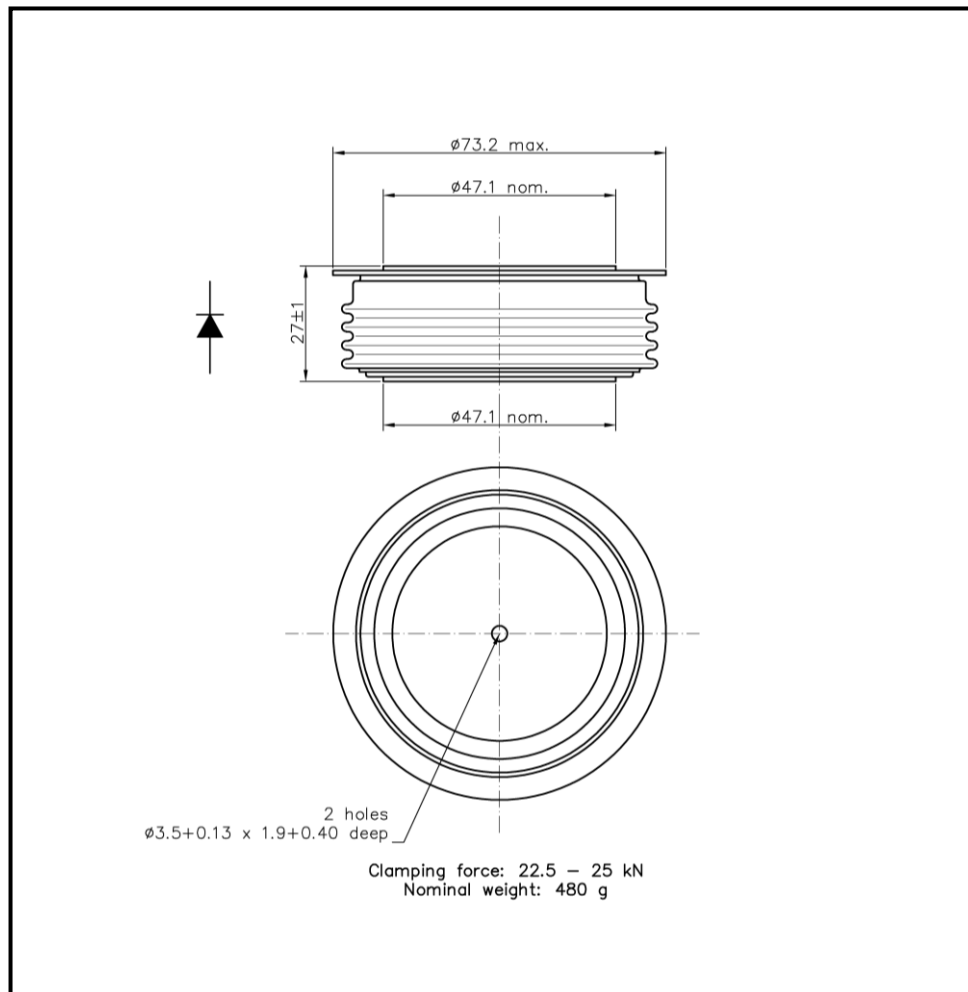

For further package information, please contact Sales & Marketing Department. All dimensions in mm, unless stated otherwise.
Do not scale.

Zakłady Elektroniczne LAMINA S.A.
Puławska 34
PL-05-500 Piaseczno
POLAND

Tel.: +48-22-7572731
Tel.: +48-22-3989409
Fax.: +48-22-3989407
e-mail: sekretariat@lamina.com.pl
www.lamina.com.pl

D95-2500

Diode



Zakłady Elektronowe
LAMINA S.A.

KKD952500, November 2004 version

CHARACTERISTICS

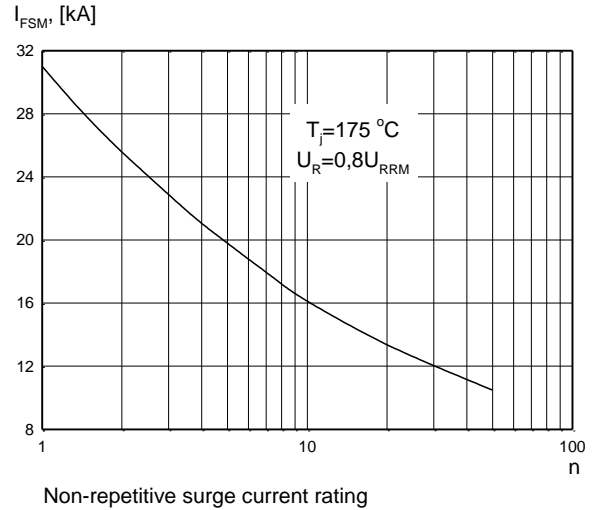
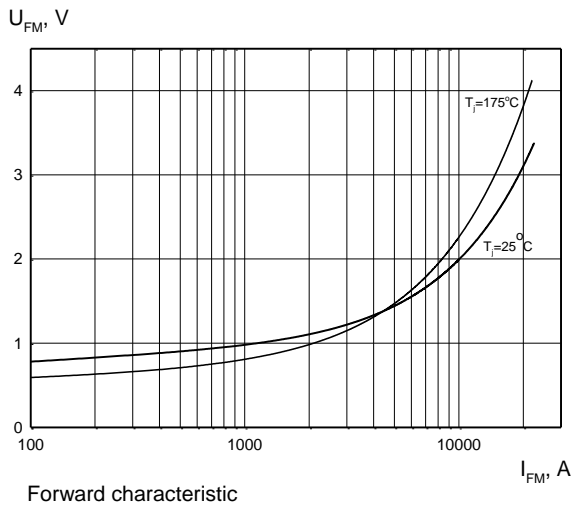
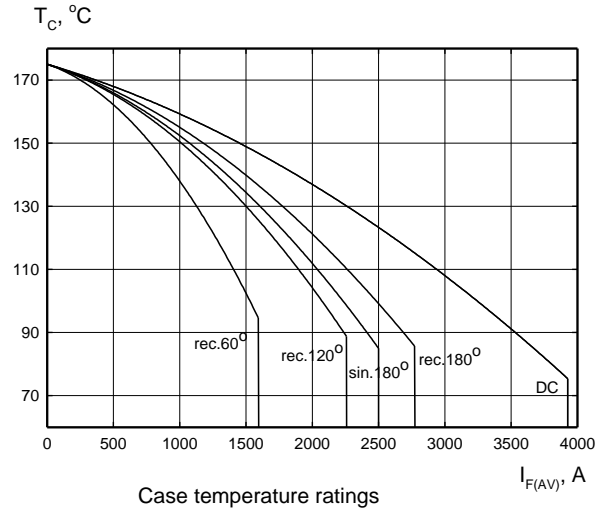
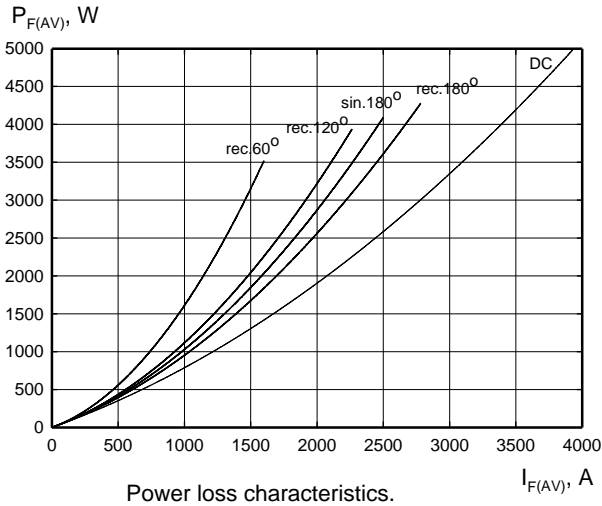

Zakłady Elektronowe LAMINA S.A.
Puławska 34
PL-05-500 Piaseczno
POLAND

Tel.: +48-22-7572731
Tel.: +48-22-3989409
Fax: +48-22-3989407
e-mail: sekretariat@lamina.com.pl
www.lamina.com.pl

D95-2500

Diode

KKD952500, November 2004 version

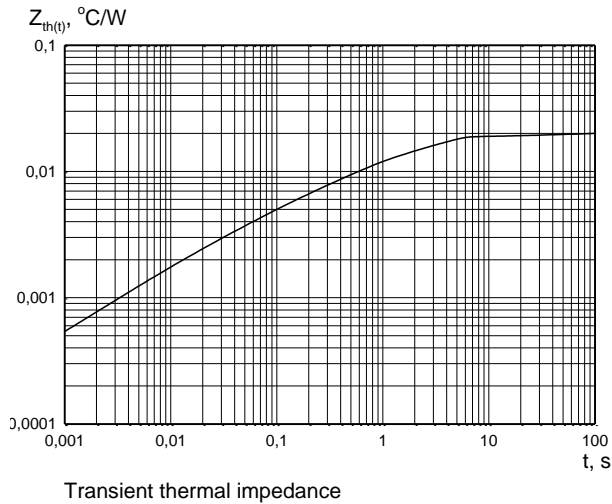

HEATSINKS

LAMINA S.I. has its own proprietary range of extruded aluminium heatsinks designed to optimise the performance of our semiconductors with natural and forced air flow. High efficiency water cooled copper heatsinks are also available.

DEVICE CLAMPS

Disc devices require the correct clamping force to ensure their best operation. LAMINA S.I. offers a wide selection of clamps to suit all of our manufactured devices.

POWER ASSEMBLY CAPABILITY

LAMINA S.I. provides a support for those customers requiring more than a basic semiconductor and offers precisely assembled Power Blocks according to factory or customer standards.

X-ON Electronics

Largest Supplier of Electrical and Electronic Components

Click to view similar products for [Diodes - General Purpose, Power, Switching category:](#)

Click to view products by [KUBARA LAMINA manufacturer:](#)

Other Similar products are found below :

[MCL4151-TR3](#) [MMBD3004S-13-F](#) [RD0306T-H](#) [RD0506LS-SB-1H](#) [RGP30G-E373](#) [DSE010-TR-E](#) [BAQ333-TR](#) [BAQ335-TR](#) [BAQ33-GS18](#) [BAS1602VH6327XT](#) [BAV17-TR](#) [BAV19-TR](#) [BAV301-TR](#) [BAW27-TAP](#) [HSC285TRF-E](#) [NSVBAV23CLT1G](#) [NTE525](#) [1SS181-TP](#) [1SS184-TP](#) [1SS193,LF](#) [1SS193-TP](#) [1SS400CST2RA](#) [SBAV99LT3G](#) [SDAA13](#) [LL4448-GS18](#) [SHN2D02FUTW1T1G](#) [LS4150GS18](#) [LS4151GS08](#) [SMMD7000LT3G](#) [FC903-TR-E](#) [1N4449](#) [1N4934-E3/73](#) [1SS226-TP](#) [APT100DL60HJ](#) [RFUH20TB3S](#) [RGP30G-E354](#) [RGP30M-E3/73](#) [D291S45T](#) [MCL4151-TR](#) [BAS 16-02V H6327](#) [BAS 21U E6327](#) [BAS 28 E6327](#) [BAS33-TAP](#) [BAS 70-02V H6327](#) [BAV300-TR](#) [BAV303-TR3](#) [BAW27-TR](#) [BAW56DWQ-7-F](#) [BAW56M3T5G](#) [BAW75-TAP](#)