



### SOT-25



#### Pin Definition:

1. Input
2. Ground
3. Enable
4. Bypass
5. Output

### DFN 2x2

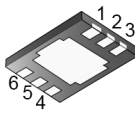

#### Pin Definition:

1. Input
2. N/C
3. Output
4. N/C
5. Ground
6. Enable

## General Description

The TS9007 series is 300mA ultra-low-noise LDO especially designed for battery-power RF and wireless applications. The TS9007 regulator achieves a low 450mV dropout at 300mA load current of 3.3V output, ultra-low output voltage noise of 15uVrms and PSRR of 57dB at 1KHz.

The TS9007 regulators are also optimized to work with low-ESR and low cost ceramic capacitors reducing the amount of board space critical in hand-held devices. The TS9007 requires only 0.47uF output capacitor for stability with and load. The TS9007 consumes less than 1uA in shutdown mode.

## Features

- 450mV Dropout at 300mA load (3.3V)
- Low quiescent current: 90uA
- Output voltage  $\pm 2\%$
- Internal current limit and thermal shutdown
- Power saving shutdown mode (<1uA)
- Only need input and output capacitors
- Build-In internal Soft-Start
- Output short-circuit current limit protection

## Applications

- Palmtops, PDA and Notebook Computers
- DSC, Handset Camera Modules
- PCMCIA Cards, PC Cameras
- USB Based Portable Devices (MPS, PMP)
- GSM/GPRS/3G RF Transceiver Modules

## Ordering Information

Part No.	Package	Packing
TS9007 $\underline{x}$ CX5 RF	SOT-25	3Kpcs / 7" Reel
TS9007 $\underline{x}$ CQ RF	DFN 2x2	3Kpcs / 7" Reel

Note: Where  $\underline{x}$  denotes voltage option, available are

- 1**= 1.2V
- A**= 1.5V
- D**= 1.8V
- K**= 2.5V
- M**= 2.7V
- N**= 2.8V
- O**= 2.9V
- P**= 3.0V
- S**= 3.3V

Contact factory for additional voltage options.

## Block Diagram

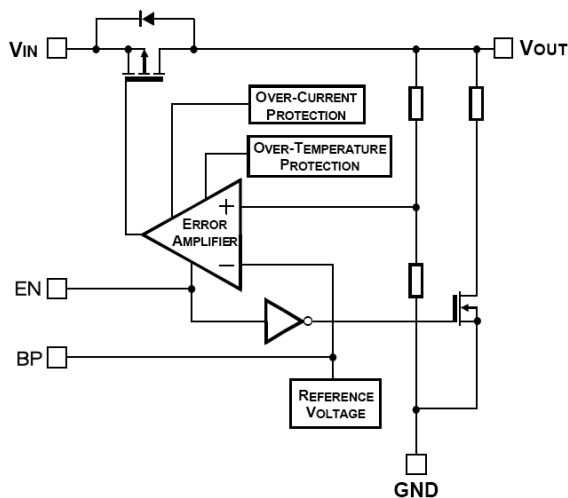

## Typical Application Circuit

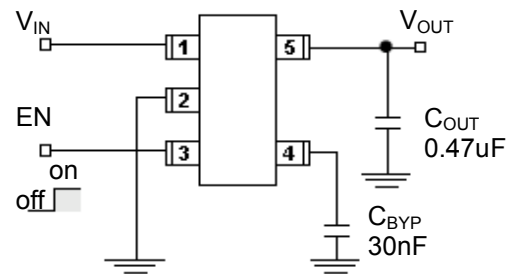

EN (Pin 3) may be connected directly to VIN (Pin1)

Low noise operation:  $C_{BYP}=30nF$ ,  $C_{OUT}>0.47uF$

Basic operation:  $C_{BYP}$ =not used,  $C_{OUT}>1uF$

**Absolute Maximum Rating**

Parameter	Symbol	Limit	Unit
Supply Voltage	$V_{IN}$	-0.3 ~ +7	V
Input Supply Voltage (Recommended)	$V_{OPR}$	+2 ~ +6	V
Output Short-Circuit Duration		Infinite	
Power Dissipation	SOT-25	300	mW
	DFN 2x2	500	
Thermal Resistance	SOT-25	250	°C/W
	DFN 2x2	165	
Junction Temperature Range	$T_J$	+150	°C
Storage Temperature Range	$T_{STG}$	-65 ~ +150	°C

Notes: Stress above the listed absolute rating may cause permanent damage to the device.

**Electrical Characteristics** ( $T_A = 25^\circ\text{C}$ ,  $V_{IN} = (V_{OUT}+1\text{V})$ ,  $C_{IN}=C_{OUT}=0.47\mu\text{F}$ ,  $V_{EN}=V_{IN}$ , unless otherwise noted.)

Parameter	Conditions	Min	Typ	Max	Unit
Output Voltage	$V_{IN} = V_O + 1\text{V}$ , $I_O=10\text{mA}$	-2.0	--	+2	%
Output Current Limit	Short-circuit output	--	200	--	mA
Maximum Output Current	$V_{IN} = V_O + 1\text{V}$ ,	300	--	--	mA
Line Regulation	$V_{IN} = (V_{OUT}+1\text{V})$ to 6V, $I_O=10\text{mA}$	--	0.3	--	%/V
Load Regulation	$V_{IN} = V_O + 1\text{V}$ , $1\text{mA} \leq I_L \leq 300\text{mA}$ , $V_{OUT} \geq 2.5\text{V}$	--	0.2	1.0	%
	$V_{IN} = V_O + 1\text{V}$ , $1\text{mA} \leq I_L \leq 200\text{mA}$ , $V_{OUT} < 2.5\text{V}$	--	0.2	1.0	
Dropout Voltage	$I_O=300\text{mA}$ , $V_{OUT} = V_O - 2\%$ , $V_{OUT} \geq 2.5\text{V}$	--	500	600	mV
	$I_O=200\text{mA}$ , $V_{OUT} = V_O - 2\%$ , $V_{OUT} < 2.5\text{V}$	--	800	1000	
Shutdown Supply Current	$EN=0\text{V}$	--	0.01	--	uA
Ground Pin Current	$I_O=0\text{mA}$	--	90	150	uA
Ripple Rejection (PSRR)	$f=100\text{Hz}$ , $I_O=1\text{mA}$	--	60	--	dB
	$f=1\text{KHz}$ , $I_O=1\text{mA}$	--	57	--	
	$f=10\text{Hz}$ , $I_O=1\text{mA}$	--	45	--	
Output Noise	$I_O=10\text{mA}$ , $f=10\text{Hz}$ to 100kHz, Bypass = 0nF	--	45	--	uVrms
	$I_O=10\text{mA}$ , $f=10\text{Hz}$ to 100kHz, Bypass = 30nF	--	15	--	
Shutdown Exit Delay (note 2)	$R_{LOAD} = 50\Omega$	--	45	300	uS
EN Logic Low Level	$V_{IN} = 2.0\text{V}$ to 5.5V	--	--	0.4	V
EN Logic High Level	$V_{IN} = 2.0\text{V}$ to 5.5V	1.5	--	$V_{IN}$	
EN Input Bias Current	$V_{IN} = 2.0\text{V}$ to 5.5V	--	--	--	uA
Thermal Shutdown	Shutdown Temperature	--	160	--	°C
Thermal Shutdown Hysteresis		--	20	--	°C

Notes:

a. The drop out voltage varies depending on output voltage selection.

Dropout is defined as  $V_{IN} - V_{OUT}$  when  $V_{OUT}$  is 100mV below  $V_{OUT}$  where  $V_{IN} = V_{OUT}+1\text{V}$  for nominal  $V_{OUT}$

b. Time needed for  $V_{OUT}$  to reach 90% of final value

## Application Information

### Enable / Shutdown

The TS9007 comes with an active-high enable pin that allows the regulator to be enabled. Forcing the enable pin low disables the regulator and puts it into the shutdown mode. This pin cannot be left floating as it may cause an undetermined state.

### Input / Output Capacitor

It is recommended to use a 0.47 $\mu$ F capacitor on the TS9007 input and a 0.47 $\mu$ F capacitor on the output. For high regulation performance, larger input capacitor values and lower ESRs provide better noise rejection and line-transient response. The output noise, load-transient response, stability, and power-supply rejection can be improved by using large output capacitors. Low ESR ceramic capacitors provide optimal performance and save space.

### Power Supply Rejection and Transient Response

The PSRR and transient response can be improved by increasing the values of the input and output bypass capacitors, and through passive filtering techniques.

## Function Description

### Description

The TS9007 is an ultra-low-noise, low-quiescent current, low-dropout linear regulator. It is supplied in a SOT-25 package for difference applications. This device can supply loads up to 300mA. As shown in the functional block diagram, the TS9007 consists of a reference and noise bypass circuit, error amplifier, output drive transistor, internal feedback voltage divider, thermal sensor, and short circuit current limiter. The internal reference is connected to the error amplifier's inverting input. The error amplifier compares this reference with the feedback voltage and amplifies the difference. If the feedback voltage is lower than the reference voltage, the pass-transistor gate is pulled low. This allows more current to pass to the output and increases the output voltage.

### Stability

The TS9007 is a high performance LDO emphasizing stability with low output capacitance. It is able to maintain stability with an output capacitor. The output capacitor can also be increased to optimize performance. The TS9007 will remain stable and in regulation with no load, unlike many other voltage regulators.

### Internal P-Channel Pass Transistor

The TS9007 features a low impedance P-channel MOSFET pass transistor. This provides several advantages over similar designs using a PNP pass transistor, including low operating power and longer battery life. The TS9007 consumes only 90 $\mu$ A of quiescent current under most conditions.

### Output Short-Circuit Current Limit

The TS9007 includes a current limiter, which monitors and controls the pass transistor's gate voltage, limiting the output current to about 200mA, for example, in a short-circuit output situation.

### Shutdown

The TS9007 also features a low-power active shutdown mode. It has a switch that turns off the device when disabled. This allows the output capacitor and load to discharge and de-energize the load. In the shutdown mode, the internal functional blocks, such as voltage reference and the error amplifier, are turned off completely, and the quiescent current is less than 1 $\mu$ A.

### Function Description (Continue)

#### **Thermal Protection Shutdown**

The thermal protection shutdown function protects the device from operating in over temperature condition. When the junction temperature exceeds +160°C, the thermal sensor signals the shutdown logic, turning off the pass transistor and allowing the IC to cool down. The thermal sensor turns the pass transistor on again after the IC's junction temperature drops to +140°C.

#### **Soft-Start Circuitry**

The TS9007 includes a soft-start circuitry to limit inrush current at turn-on. During power up, the output capacitor and output load are charged with a reduced output current. Shortly after the initial power up, the soft-start feature is terminated and normal operation is resumed.

**Electrical Characteristics Curve**

**Dropout Voltage vs. Load Current**

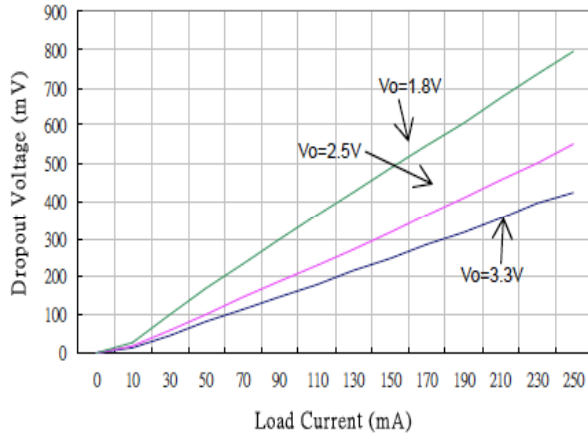

**Dropout Voltage vs. Temperature**

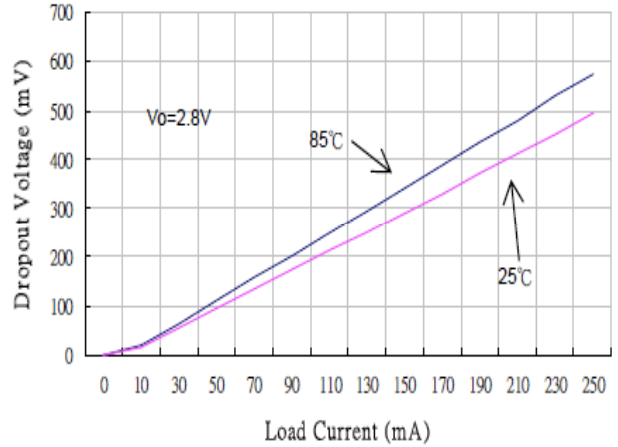

**Ground Current vs. Input Voltage**

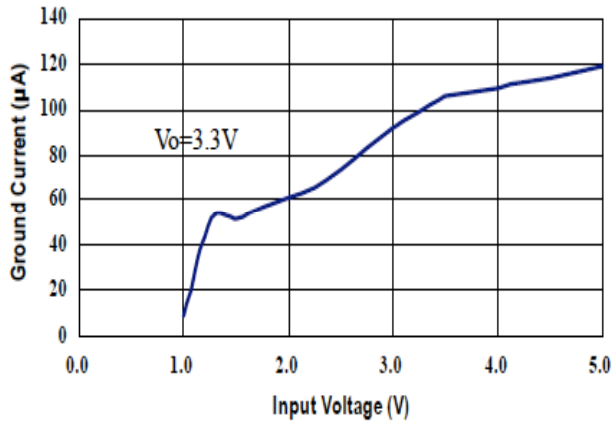

**Output Voltage vs. Temperature**

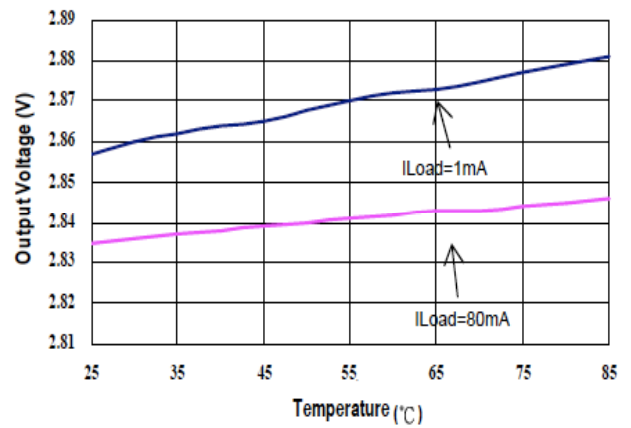

**PSRR vs. Frequency**

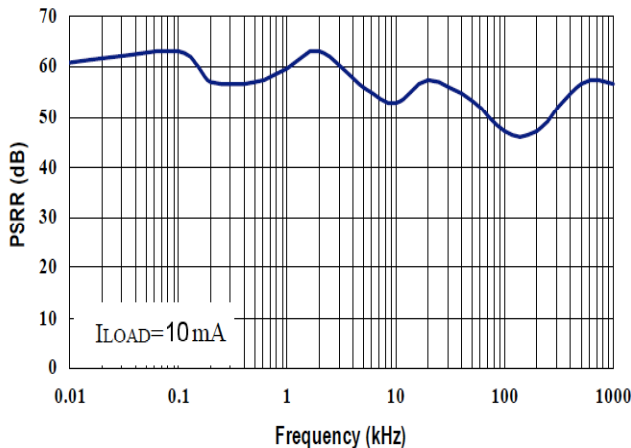

**PSRR vs. Frequency**

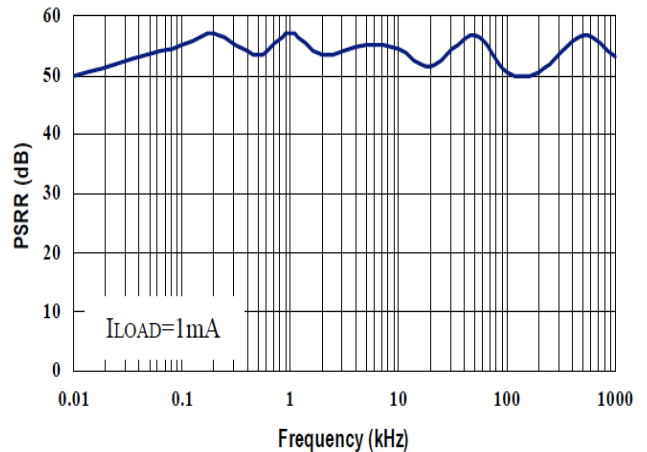

**SOT-25 Mechanical Drawing**

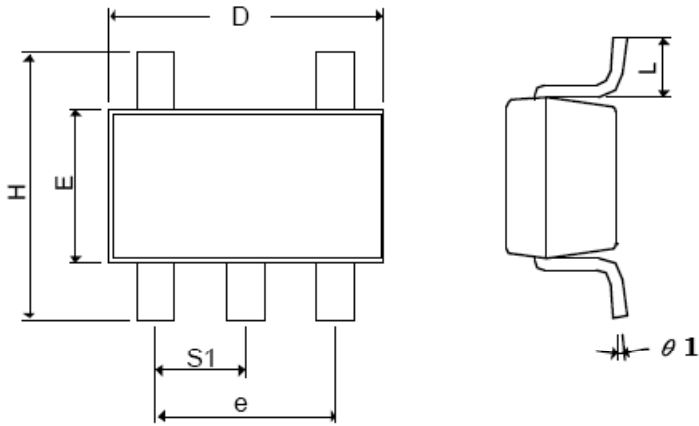

SOT-25 DIMENSION				
DIM	MILLIMETERS		INCHES	
	MIN	MAX	MIN	MAX.
A+A1	0.09	1.25	0.0354	0.0492
B	0.30	0.50	0.0118	0.0197
C	0.09	0.25	0.0035	0.0098
D	2.70	3.10	0.1063	0.1220
E	1.40	1.80	0.0551	0.0709
E	1.90 BSC		0.0748 BSC	
H	2.40	3.00	0.09449	0.1181
L	0.35 BSC		0.0138 BSC	
θ1	0°	10°	0°	10°
S1	0.95 BSC		0.0374 BSC	

Front View

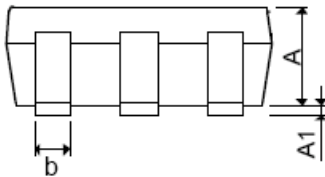

**Marking Diagram**

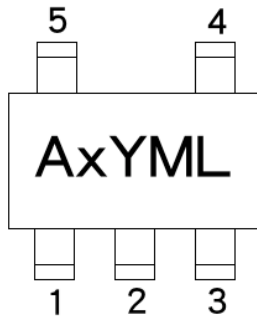

- A** = Device Code
- X** = Fixed Output Voltage Code  
**1**=1.2V, **A**=1.5V, **D**=1.8V, **K**=2.5V, **M**=2.7V, **N**=2.8V, **O**=2.9V  
**P**=3.0V, **S**=3.3V
- Y** = Year Code
- M** = Month Code  
**(A=Jan, B=Feb, C=Mar, D=Apl, E=May, F=Jun, G=Jul, H=Aug, I=Sep, J=Oct, K=Nov, L=Dec)**
- L** = Lot Code

**DFN 2x2 Mechanical Drawing**

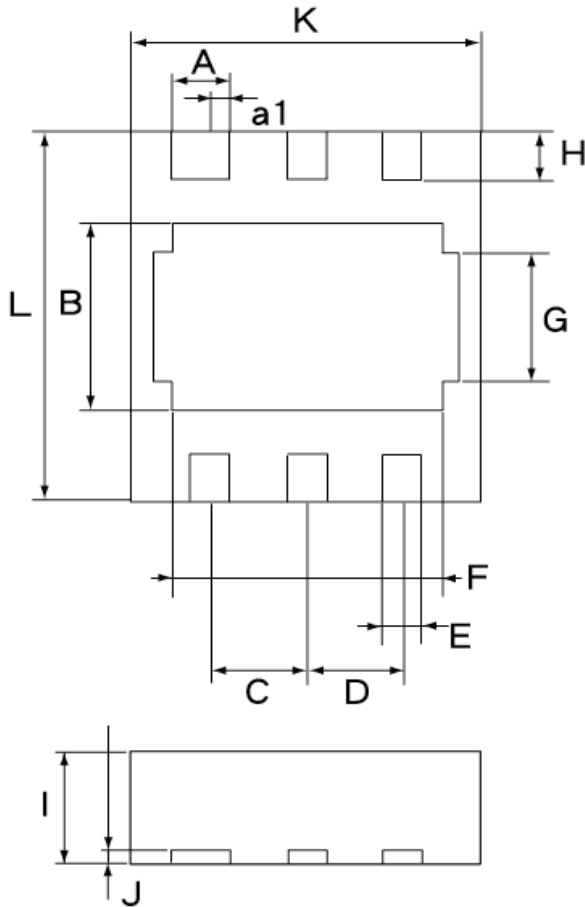

DFN 2x2 DIMENSION				
DIM	MILLIMETERS		INCHES	
	MIN	MAX	MIN	MAX
A	0.25	0.35	0.0098	0.0138
a1	0.10 (typ)		0.0039 (typ)	
B	0.90	1.10	0.0354	0.0433
C	0.50 (typ)		0.0197 (typ)	
D	0.50 (typ)		0.0197 (typ)	
E	0.15	0.25	0.0059	0.0098
F	1.30	1.50	0.0512	0.0591
G	0.67	0.73	0.0264	0.0287
H	0.20	0.30	0.0079	0.0118
I	0.60 (MAX.)		0.0236 (MAX.)	
J	0.07 (MAX.)		0.0028 (MAX.)	
K	1.75	1.85	0.0689	0.0728
L	1.95	2.05	0.0768	0.0807

**Marking Diagram**

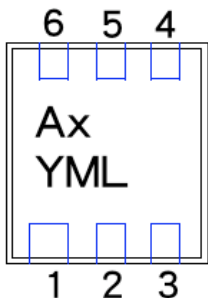

- A** = Device Code
- X** = Fixed Output Voltage Code  
 1=1.2V, **A**=1.5V, **D**=1.8V, **K**=2.5V, **M**=2.7V, **N**=2.8V, **O**=2.9V  
**P**=3.0V, **S**=3.3V
- Y** = Year Code
- M** = Month Code  
 (**A**=Jan, **B**=Feb, **C**=Mar, **D**=Apr, **E**=May, **F**=Jun, **G**=Jul, **H**=Aug,  
**I**=Sep, **J**=Oct, **K**=Nov, **L**=Dec)
- L** = Lot Code

### Notice

Specifications of the products displayed herein are subject to change without notice. TSC or anyone on its behalf, assumes no responsibility or liability for any errors or inaccuracies.

Information contained herein is intended to provide a product description only. No license, express or implied, to any intellectual property rights is granted by this document. Except as provided in TSC's terms and conditions of sale for such products, TSC assumes no liability whatsoever, and disclaims any express or implied warranty, relating to sale and/or use of TSC products including liability or warranties relating to fitness for a particular purpose, merchantability, or infringement of any patent, copyright, or other intellectual property right.

The products shown herein are not designed for use in medical, life-saving, or life-sustaining applications. Customers using or selling these products for use in such applications do so at their own risk and agree to fully indemnify TSC for any damages resulting from such improper use or sale.



## X-ON Electronics

Largest Supplier of Electrical and Electronic Components

*Click to view similar products for [Taiwan Semiconductor manufacturer](#):*

Other Similar products are found below :

[MBR1060 C0](#) [GBPC2508M](#) [1SMA4753](#) [S3D](#) [SMCJ24A R6](#) [ES2J](#) [RSFDL](#) [RSFML](#) [P4SMA200A R3G](#) [ES1GL](#) [SS15](#) [TST40L150CW C0G](#)  
[1N5392G](#) [1N5398G](#) [1N5395G](#) [1N5397G](#) [GBPC2501W](#) [TSM1NB60CP](#) [TSM2318CX](#) [MBS10](#) [1.5KE33CA-R0](#) [1.5KE24CA-R0](#) [S1B R2](#)  
[1.5SMC36A-R6](#) [GBPC2502](#) [SMAJ26CA R2](#) [LL4004G](#) [TS1117BCP-5.0](#) [SS14 F2](#) [S10MC V7G](#) [SMDJ48CA HR7G](#) [TS78L05CT A3G](#)  
[TSM60N750CP](#) [TS5205CX525](#) [GBPC2508](#) [TS4B06G](#) [TSM9926DCS](#) [P4SMA15CA R2](#) [SF3004PT](#) [GBPC5008M T0](#) [ABS15M RGG](#)  
[TS1117BCP-3.3](#) [SMBJ36A-M4G](#) [MBS8 RC](#) [1.5KE39A-R0](#) [TS2940CZ-5.0](#) [TSM80N950CP ROG](#) [TSD30H100CW C0G](#) [RS1DLW RVG](#)  
[BZX85C18-R0G](#)