

# OLED DISPLAY MODULE

## Application Notes

<b>PRODUCT NUMBER</b>	<b>DD-25664YW-3A/4A with EVK board</b> <b>DD-25664BE-3A/4A with EVK board</b>
---------------------------	--

## TABLE OF CONTENTS

<b>1</b>	<b>EVK SCHEMATIC</b> .....	<b>4</b>
<b>2</b>	<b>SYMBOL DEFINITION</b> .....	<b>5</b>
<b>3</b>	<b>TIMING CHARACTERISTICS</b> .....	<b>6</b>
3.1	80 SERIES MPU PARALLEL INTERFACE .....	6
3.2	6800 SERIES MPU PARALLEL INTERFACE .....	7
3.3	SPI(4 WIRE) INTERFACE.....	8
3.4	SPI(3-WIRE) INTERFACE .....	9
<b>4</b>	<b>CONNECTION BETWEEN OLED AND EVK</b> .....	<b>10</b>
<b>5</b>	<b>POWER DOWN AND POWER UP SEQUENCE</b> .....	<b>12</b>
<b>6</b>	<b>HOW TO USE THE DD-25664XX-3A-4A</b> .....	<b>13</b>
6.1	RECOMMENDED INITIAL CODE .....	14

Product No.	DD-25664XX-3A/4A	REV. A

Page	2 / 14
------	--------

REVISION RECORD

Rev.	Date	Page	Chapt.	Comment	ECR no.
A	28 <sup>th</sup> May 2008			First Issue	

Product No.	DD-25664XX-3A/4A	REV. A

Page	3 / 14
------	--------

# 1 EVK Schematic

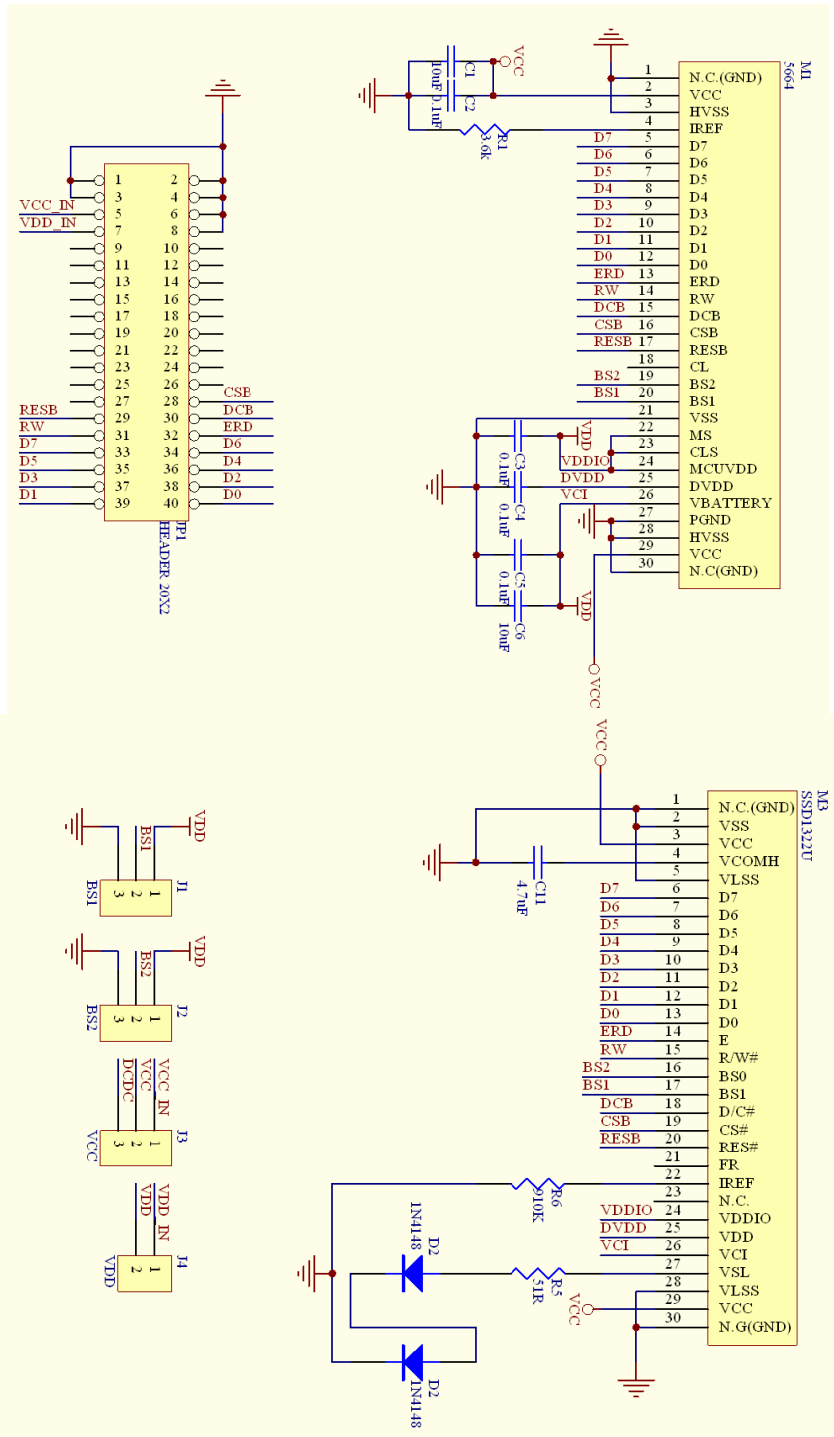

Product No.	DD-25664XX-3A/4A	REV. A
-------------	------------------	--------

Page	4 / 14
------	--------

## 2 SYMBOL DEFINITION

**D0-D7** : These pins are bi-directional data bus connecting to the MCU data bus.

Unused pins are recommended to tie LOW. (Except for D2 pin in SPI mode)

**E/RD#** : This pin is MCU interface input.

When interfacing to a 6800-series microprocessor, this pin will be used as the Enable

(E) signal. Read/write operation is initiated when this pin is pulled HIGH and the chip is selected.

When connecting to an 8080-microprocessor, this pin receives the Read (RD#) signal. Read operation is initiated when this pin is pulled LOW and the chip is selected. When serial interface is selected, this pin E(RD#) must be connected to VSS.

**W/R#** : This pin is read / write control input pin connecting to the MCU interface. When interfacing to a 6800-series microprocessor, this pin will be used as Read/Write (R/W#) selection input. Read mode will be carried out when this pin is pulled HIGH and write mode when LOW.

When 8080 interface mode is selected, this pin will be the Write (WR#) input. Data write operation is initiated when this pin is pulled LOW and the chip is selected. When serial interface is selected, this pin R/W (WR#) must be connected to VSS.

**D/C#** : This pin is Data/Command control pin connecting to the MCU. When the pin is pulled HIGH, the content at D[7:0] will be interpreted as data. When the pin is pulled LOW, the content at D[7:0] will be interpreted as command.

**RES#** : This pin is reset signal input.

When the pin is pulled LOW, initialization of the chip is executed. Keep this pin pull HIGH during normal operation.

**CS#** : This pin is the chip select input connecting to the MCU. The chip is enabled for MCU communication only when CS# is pulled LOW.

**BS0/BS1** : These pins are MCU interface selection input. See the following table:

<b>BS[1:0]</b>	<b>Bus Interface Selection</b>
00	4 line SPI
01	3 line SPI
10	8-bit 8080 parallel
11	8-bit 6800 parallel

**VCC** : This is the most positive voltage supply pin of the chip. It can be supplied externally or generated internally by using internal DC-DC voltage converter.

**VDD** : This is a voltage supply pin. It must be connected to external source.

**VDDIO** : Power supply for interface logic level. It should be matched with the MCU interface voltage level.

**VCI** : Low voltage power supply. VCI must always be equal to or higher than VDD and VDDIO.

**VSS** : This is a ground pin. It also as a reference for the logic pins and the OLED driving voltages. It must be connected to external ground.

**NC** : These pins should be left open individually.

Product No.	DD-25664XX-3A/4A	REV. A

Page	5 / 14
------	--------

### 3 Timing characteristics

#### 3.1 80 Series MPU parallel interface

( $V_{DD} - V_{SS} = 2.4$  to  $2.6V$ ,  $V_{DDIO} = 1.6V$ ,  $V_{CI} = 3.3V$ ,  $T_A = 25^\circ C$ )

Symbol	Parameter	Min	Typ	Max	Unit
$t_{cycle}$	Clock Cycle Time	300	-	-	ns
$t_{AS}$	Address Setup Time	10	-	-	ns
$t_{AH}$	Address Hold Time	0	-	-	ns
$t_{DSW}$	Write Data Setup Time	40	-	-	ns
$t_{DHW}$	Write Data Hold Time	7	-	-	ns
$t_{DHR}$	Read Data Hold Time	20	-	-	ns
$t_{OH}$	Output Disable Time	-	-	70	ns
$t_{ACC}$	Access Time	-	-	140	ns
$t_{PWL R}$	Read Low Time	150	-	-	ns
$t_{PWL W}$	Write Low Time	60	-	-	ns
$t_{PWH R}$	Read High Time	60	-	-	ns
$t_{PWH W}$	Write High Time	60	-	-	ns
$t_R$	Rise Time	-	-	15	ns
$t_F$	Fall Time	-	-	15	ns
$t_{CS}$	Chip select setup time	0	-	-	ns
$t_{CSH}$	Chip select hold time to read signal	0	-	-	ns
$t_{CSF}$	Chip select hold time	20	-	-	ns

**Table 1: 80-Series MPU Parallel Interface Write Timing Characteristics**

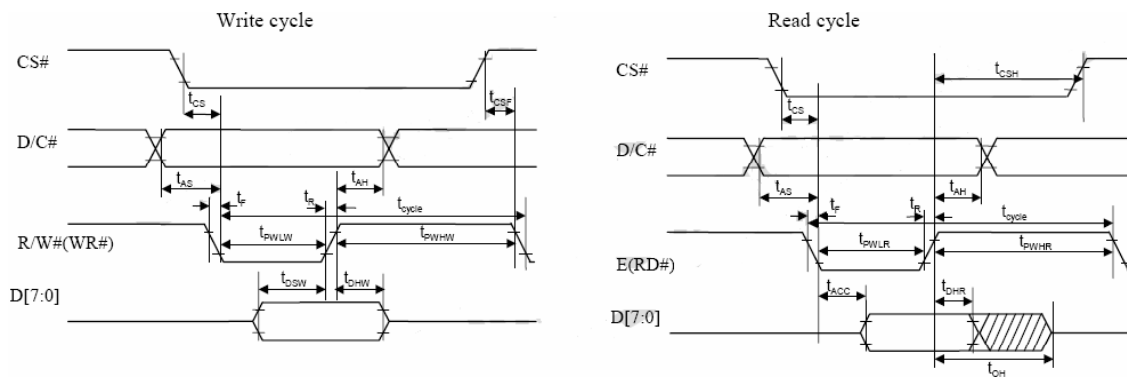

**Figure 1: 80-series MPU parallel interface write timing diagram**

Product No.	DD-25664XX-3A/4A	REV. A
-------------	------------------	--------

Page	6 / 14
------	--------

### 3.2 68xx- Series MPU parallel interface

( $V_{DD} - V_{SS} = 2.4$  to  $2.6V$ ,  $V_{DDIO} = 1.6V$ ,  $V_{CI} = 3.3V$ ,  $T_A = 25^\circ C$ )

Symbol	Parameter	Min	Typ	Max	Unit
$t_{cycle}$	Clock Cycle Time	300	-	-	ns
$t_{AS}$	Address Setup Time	10	-	-	ns
$t_{AH}$	Address Hold Time	0	-	-	ns
$t_{DSW}$	Write Data Setup Time	40	-	-	ns
$t_{DHW}$	Write Data Hold Time	7	-	-	ns
$t_{DHR}$	Read Data Hold Time	20	-	-	ns
$t_{OH}$	Output Disable Time	-	-	70	ns
$t_{ACC}$	Access Time	-	-	140	ns
$PW_{CSL}$	Chip Select Low Pulse Width (read)	120	-	-	ns
	Chip Select Low Pulse Width (write)	60	-	-	ns
$PW_{CSH}$	Chip Select High Pulse Width (read)	60	-	-	ns
	Chip Select High Pulse Width (write)	60	-	-	ns
$t_R$	Rise Time	-	-	15	ns
$t_F$	Fall Time	-	-	15	ns

**Table 2: 6800-Series MPU Parallel Interface Write Timing Characteristics**

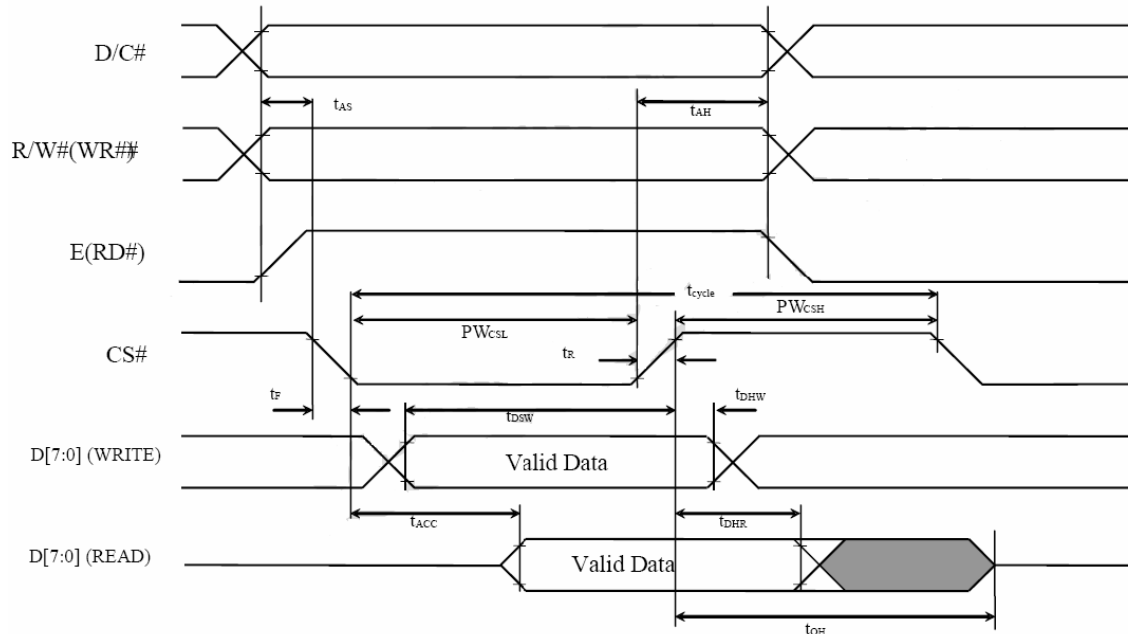

**Figure 2: 6800-Series MPU Parallel Interface Write Timing diagram**

Product No.	DD-25664XX-3A/4A	REV. A

Page	7 / 14
------	--------

### 3.3 SPI(4 WIRE) INTERFACE

( $V_{DD} - V_{SS} = 2.4$  to  $2.6V$ ,  $V_{DDIO}=1.6V$ ,  $V_{CI} = 3.3V$ ,  $T_A = 25^{\circ}C$ )

Symbol	Parameter	Min	Typ	Max	Unit
$t_{cycle}$	Clock Cycle Time	100	-	-	ns
$t_{AS}$	Address Setup Time	15	-	-	ns
$t_{AH}$	Address Hold Time	15	-	-	ns
$t_{CSS}$	Chip Select Setup Time	20	-	-	ns
$t_{CSH}$	Chip Select Hold Time	10	-	-	ns
$t_{DSW}$	Write Data Setup Time	15	-	-	ns
$t_{DHW}$	Write Data Hold Time	15	-	-	ns
$t_{CLKL}$	Clock Low Time	20	-	-	ns
$t_{CLKH}$	Clock High Time	20	-	-	ns
$t_R$	Rise Time	-	-	15	ns
$t_F$	Fall Time	-	-	15	ns

**Table 3: Serial Peripheral Interface(4-wire) Timing Characteristics**

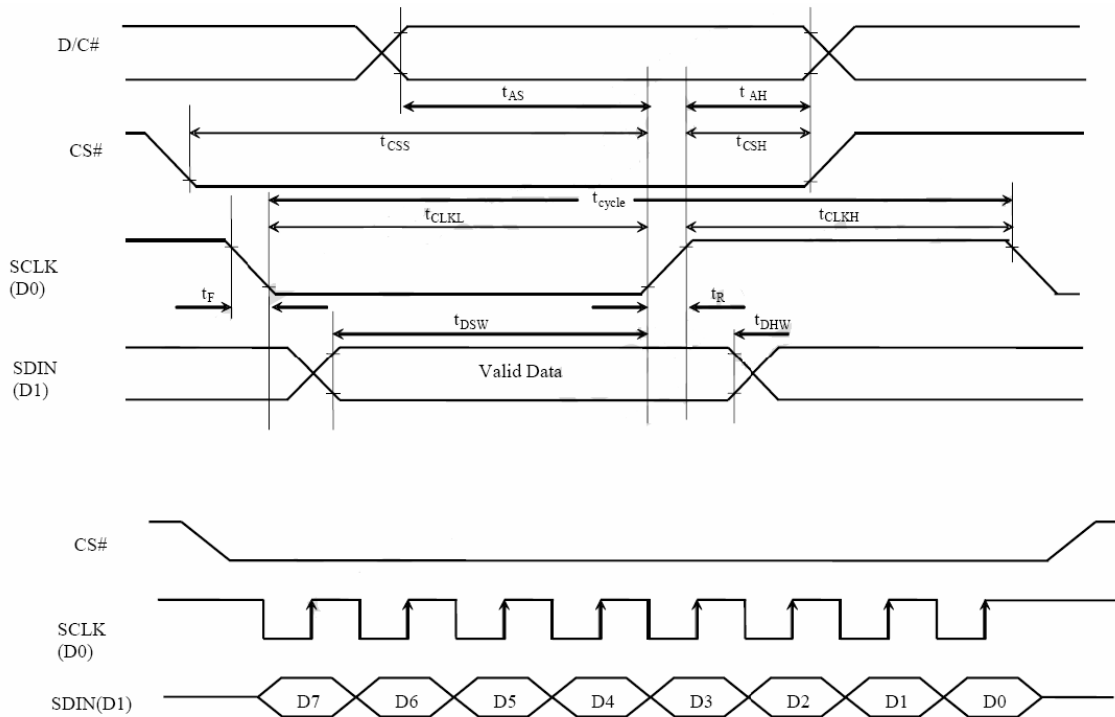

Product No.	DD-25664XX-3A/4A	REV. A
-------------	------------------	--------

Page	8 / 14
------	--------



Figure 3: Serial Peripheral Interface(4 WIRE) Timing diagram

### 3.4 SPI(3-WIRE) INTERFACE

( $V_{DD} - V_{SS} = 2.4$  to  $2.6V$ ,  $V_{DDIO} = 1.6V$ ,  $V_{CI} = 3.3V$ ,  $T_A = 25^\circ C$ )

Symbol	Parameter	Min	Typ	Max	Unit
$t_{cycle}$	Clock Cycle Time	100	-	-	ns
$t_{AS}$	Address Setup Time	15	-	-	ns
$t_{AH}$	Address Hold Time	15	-	-	ns
$t_{CSS}$	Chip Select Setup Time	20	-	-	ns
$t_{CSH}$	Chip Select Hold Time	10	-	-	ns
$t_{DSW}$	Write Data Setup Time	15	-	-	ns
$t_{DHW}$	Write Data Hold Time	15	-	-	ns
$t_{CLKL}$	Clock Low Time	20	-	-	ns
$t_{CLKH}$	Clock High Time	20	-	-	ns
$t_R$	Rise Time	-	-	15	ns
$t_F$	Fall Time	-	-	15	ns

Table 4: Serial Peripheral Interface(3 wire) Timing Characteristics

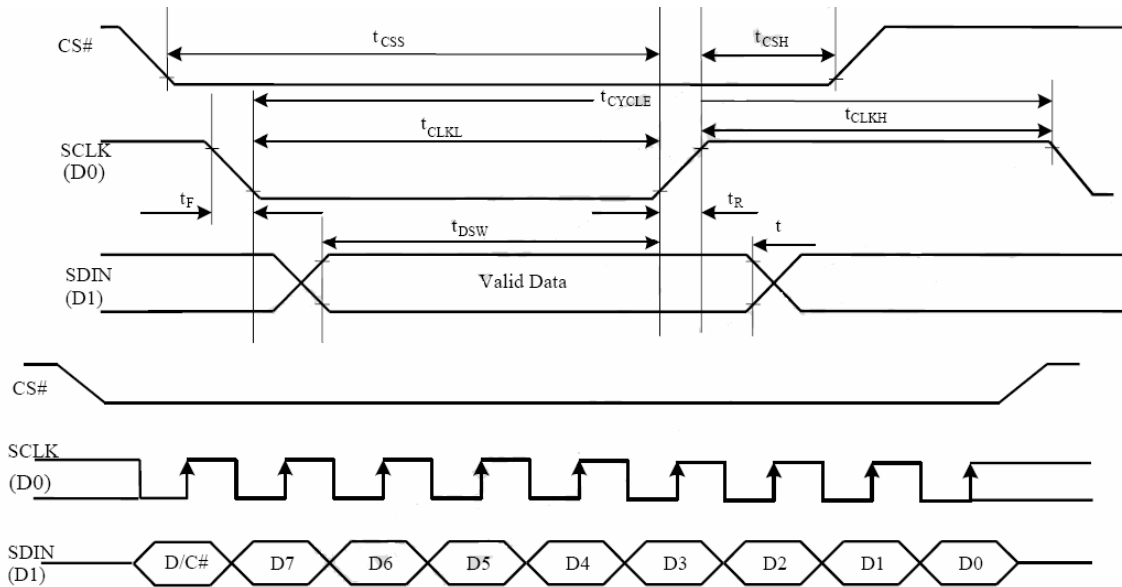
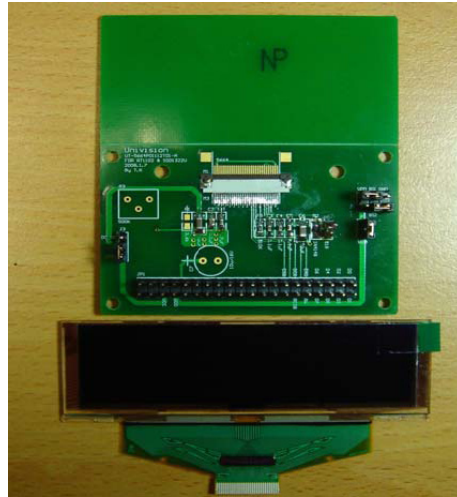

Figure 4: Serial Peripheral Interface(3-wire) Timing diagram

Product No.	DD-25664XX-3A/4A	REV. A
-------------	------------------	--------

Page	9 / 14
------	--------

## 4 Connection Between OLED and EVK



**Figure 5 EVK PCB and DD-25664XX-3A-4A Module**

The DD-25664XX-3A-4A are COF type module; please refer to figure 1 & 2. User can use leading wire to connect EVK with customers systems. The example shown in Fig 6.

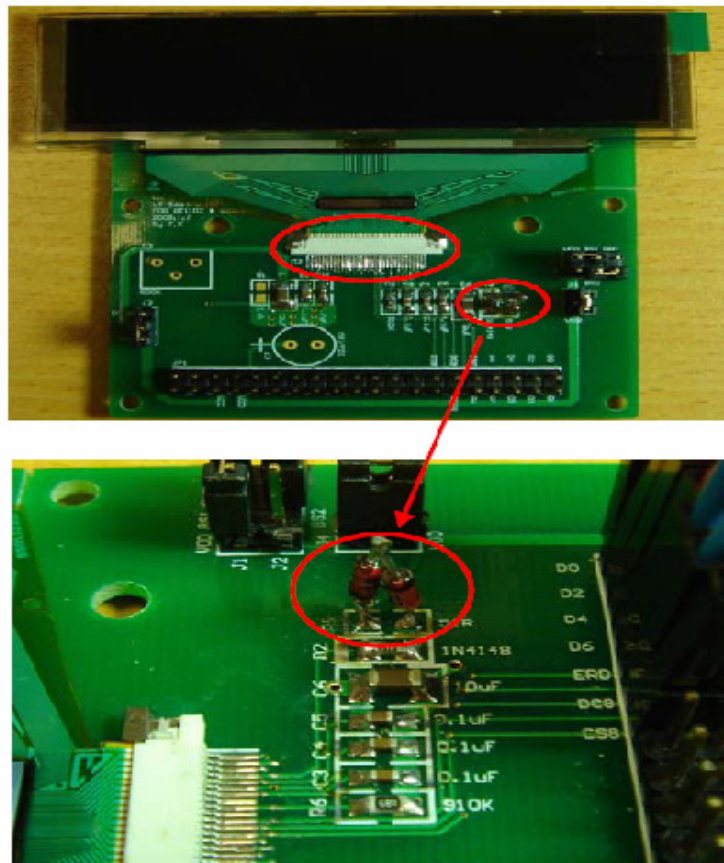

Product No.	DD-25664XX-3A/4A	REV. A

Page	10 / 14
------	---------

**Figure 6 combination of the module and EVK**

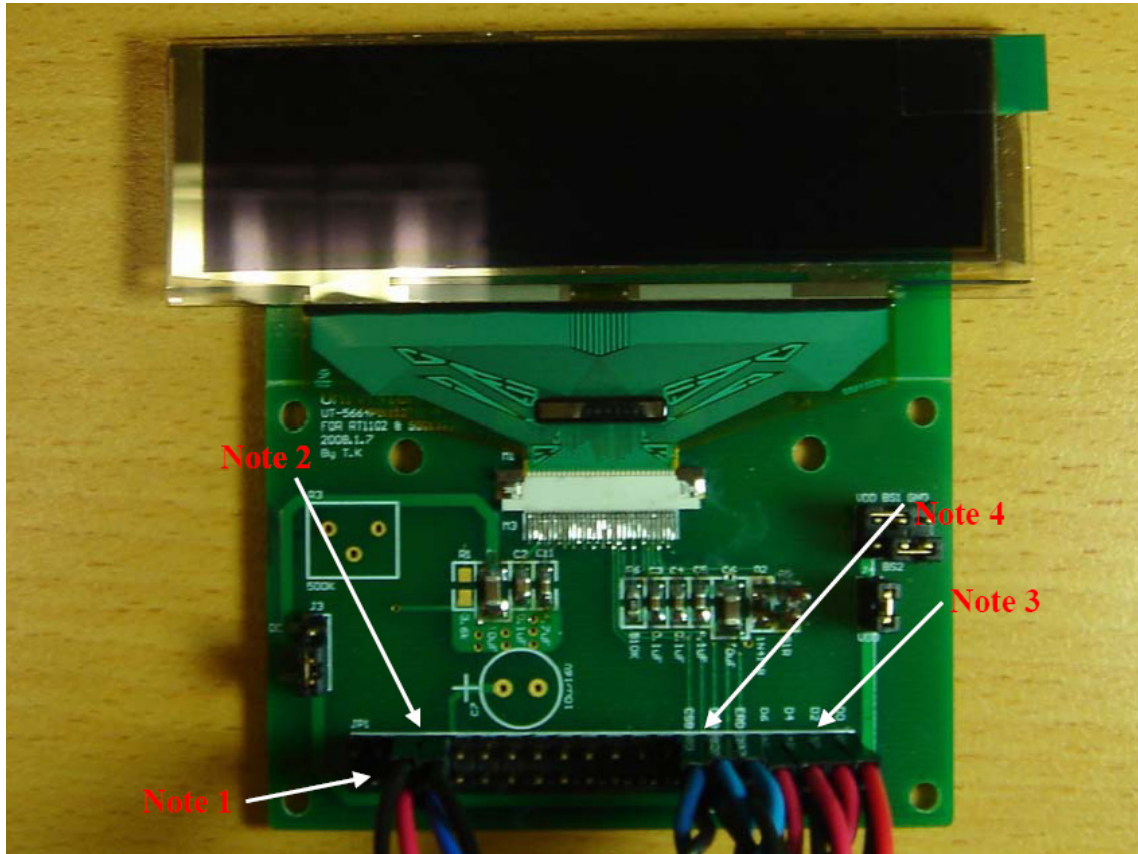

**Figure 7 EVK with test platform**

Note 1: It is OLED high voltage supply

Note 2: It is logic voltage supply

Note 3: Those are leading wire connect to control board. Those are data pin (D0~D7)

Note 4: Those are leading wire connect to control board. Those are control pin.  
(E,R/W,D/C,RES,CS)

Product No.	DD-25664XX-3A/4A	REV. A

Page	11 / 14
------	---------

## 5 Power down and Power Up sequence

To protect the OLED panel and extend the panel life time the driver IC power up/down routine should include a delay period between high voltage and low voltage power sources during turn on/off. So that the panel has enough time to charge up or discharge before/ after operation.

### Power up Sequence:

1. Power up  $V_{DD}$
2. Send Display off command
3. Driver IC Initial Setting
4. Clear Screen
5. Power up  $V_{CC}$
6. Delay 100ms  
(when  $V_{CC}$  is stable)
7. Send Display on command

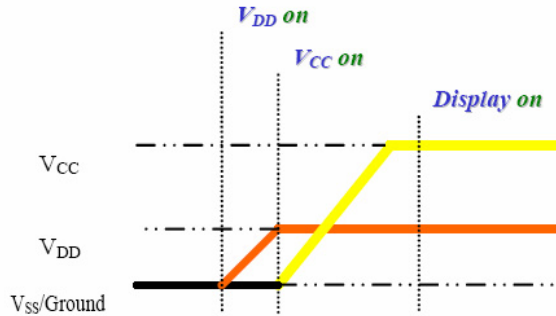

### Power down Sequence:

1. Send Display off command
2. Power down  $V_{CC}$
3. Delay 100ms  
(when  $V_{CC}$  is reach 0 and  
panel is completely  
discharges)
4. Power down  $V_{DD}$

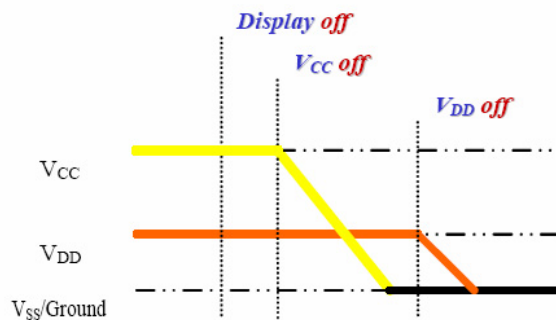

Product No.	DD-25664XX-3A/4A	REV. A

Page	12 / 14
------	---------

## 6 How to use the DD-25664XX-3A-4A

### Initial step flow

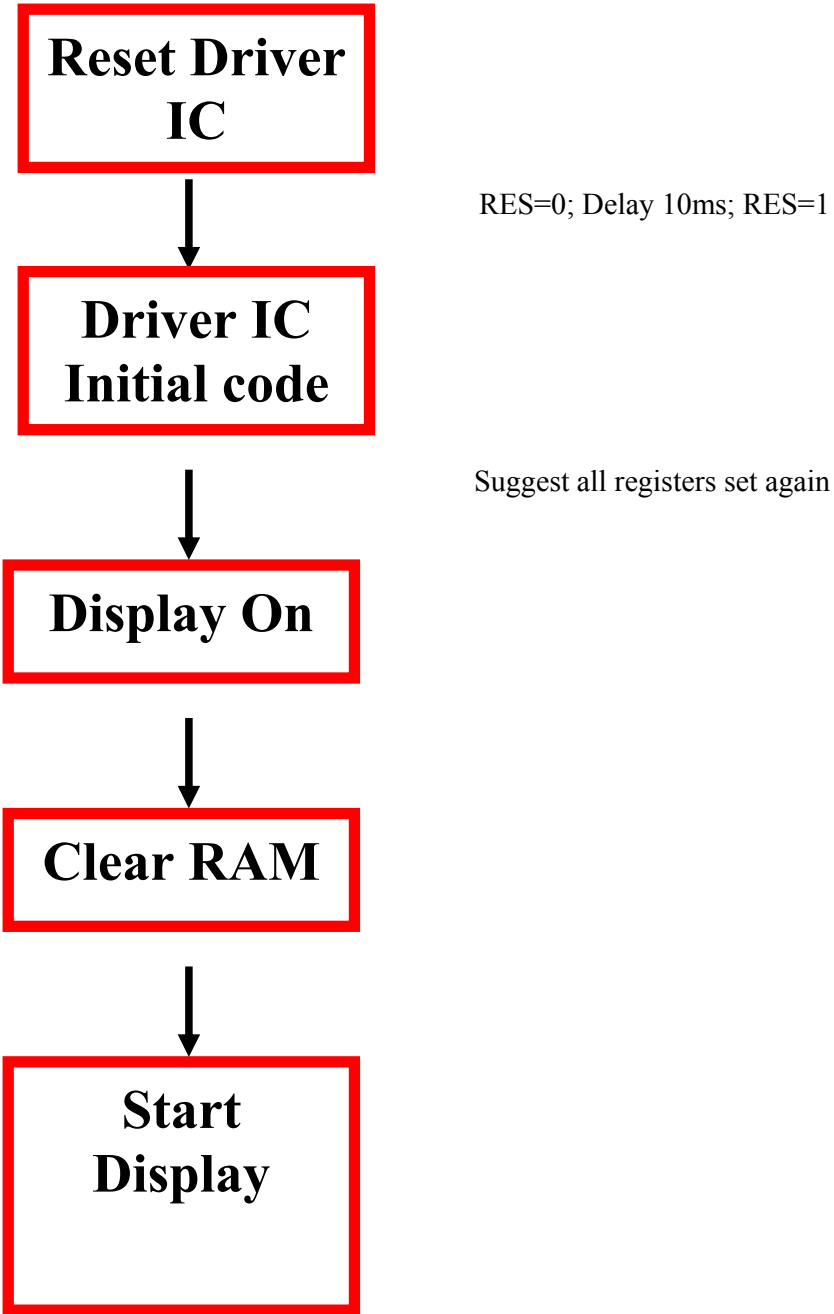

Product No.	DD-25664XX-3A/4A	REV. A
-------------	------------------	--------

Page	13 / 14
------	---------

**6.1 Recommended Initial code**

---

Product No.	DD-25664XX-3A/4A	REV. A

Page	14 / 14
------	---------

## **X-ON Electronics**

Largest Supplier of Electrical and Electronic Components

*Click to view similar products for [Densitron](#) manufacturer:*

Other Similar products are found below :

[DMT043QQNTNT0-1C](#) [DMT066YYHLNT0-1A](#) [DMT028QVNTNT0S-1A](#) [DMT080YYNLCMU-1A](#) [DMT024QVNUNT0-2C](#)

[DMT028QVHXCMI-1A](#) [DMT080YYNLNT0-1A](#) [DMT024QVNUCMI-2A](#) [DD-160128FC-2B](#) [LMR4048BG2C16HNG/5V](#)