

Conectores SUB-D y Caperuzas SUB-D Connectors and Hoods Connecteurs SUB-D et Capots

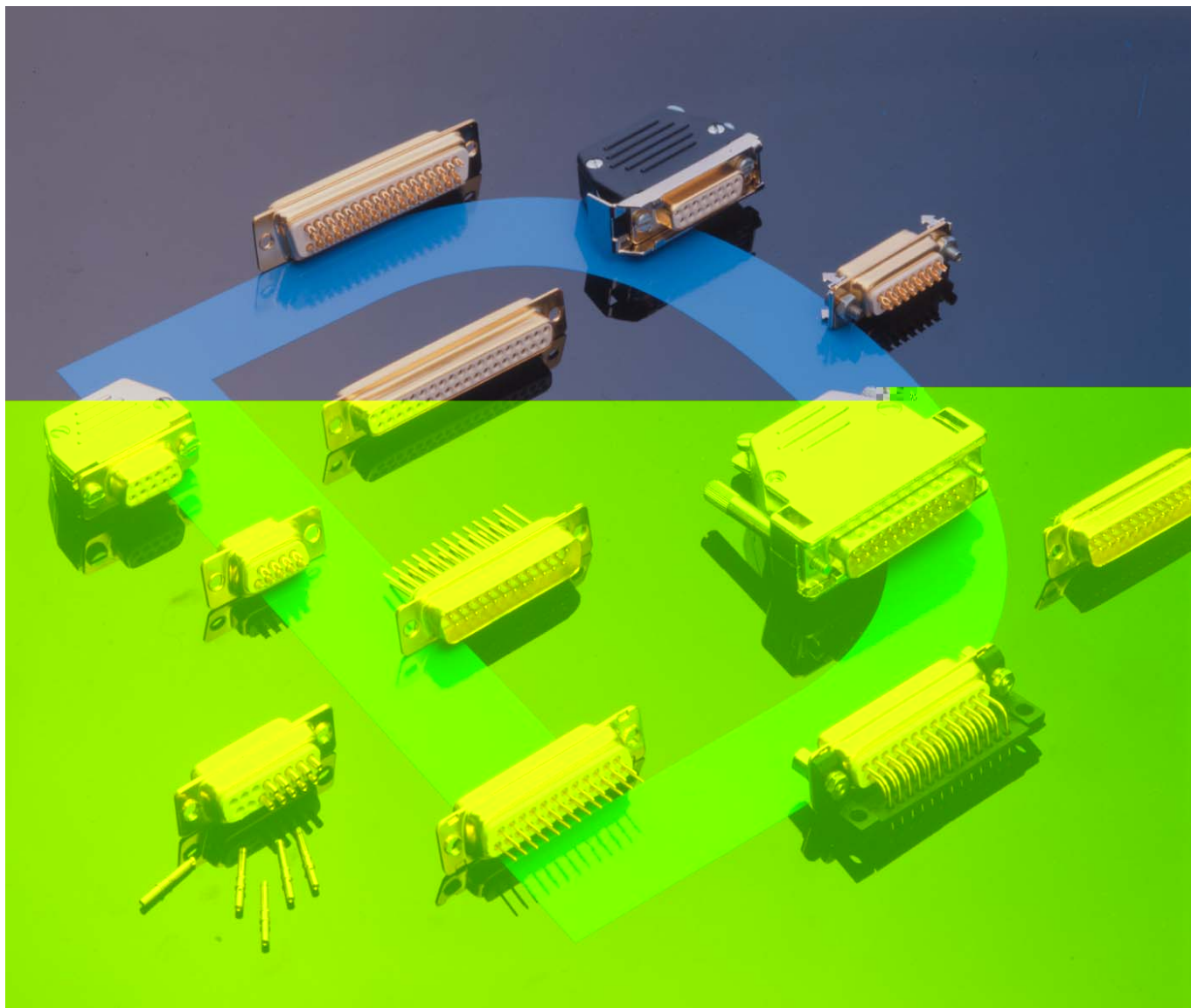

Presentación / Introduction / Présentation

Como fabricante de una amplia gama de conectores profesionales, abarca las series circulares, rectangulares, sub-miniatura y especiales.

Su campo de aplicación cubre desde la informática hasta los ferrocarriles, incluyendo las telecomunicaciones, instrumentación y control e industria en general. Su tecnología avanzada, su calidad y la fiabilidad de producto, queda certificado por la amplitud de clientes de todos los sectores que los utilizan, tanto nacionales como extranjeros.

As a manufacturer of a wide range of professional connectors, we offer a circular and rectangular series, D-SUB and custom made.

Connectors have a wide variety of applications from data processing to railways, telecommunications instrumentation, control systems and industry in general.

Thanks to a professional team with a long experience in connectors and an ongoing R + D department, we are successfully supplying a wide range of customers both national & international.

Comme fabricant de connecteurs professionnels, nous offrons des connecteurs circulaires, rectangulaires, SUB-D et spéciaux.

Ces connecteurs s'utilisent du secteur de l'informatique jusqu'au secteur des chemins de fer, en passant par le télécom, équipement machine outil, et industries diverses.

La technologie avancée, la qualité et fiabilité de nos produits, se reconnaît dans la grande variété de clients, soit nationaux comme internationaux.

Índice / Index / Index

Presentación.....	2
Índice.....	2
Descripción del producto.....	3
Versiones de contactos.....	4
Dimensiones carcasa SUB-D.....	5
Soluciones fáciles para problemas EMI/RFI.....	6
Retículas de montaje en C.I.....	7 y 8
Dimensiones aconsejadas.....	9 y 10
Esquemas de montaje con escuadra de plástico.....	11
Esquemas de montaje con escuadra metálica.....	12
Conectores acodados montados con escuadras.....	13
Utillajes para contactos a pinzar.....	14
Designación comercial.....	15 y 16
Caperuzas.....	17 y 18
Caperuzas C-CE.....	19
Caperuzas CT.....	20
Caperuzas CTI.....	21
Accesorios.....	22
Caperuzas prolongadoras.....	23
Caperuza CT 28 y para cable plano.....	24
Designación comercial.....	25
Conector de doble entrada para C.I.....	26
Retículas de montaje en C.I.....	27 y 28
Designación comercial.....	29 y 30

Introduction.....	2
Index.....	2
Product description.....	3
Types of contacts.....	4
Dimensions SUB-D shell.....	5
Easy solutions to EMI / RFI problems.....	6
Board drilling details.....	7 y 8
Recommended dimensions.....	9 y 10
Assembly diagrams with plastic brackets.....	11
Assembly diagrams with metal brackets.....	12
Right-angled connectors mounted with brackets.....	13
Tools for crimp type contacts.....	14
Ordering code.....	15 y 16
Hoods.....	17 y 18
C-CE Hoods.....	19
CT Hoods.....	20
CTI Hoods.....	21
Accessories.....	22
Extension hoods.....	23
CT 28 Hood and hood for flat cable.....	24
Ordering code.....	25
Stacked assemblies.....	26
Board drilling details.....	27 y 28
Ordering code.....	29 y 30

Présentation.....	2
Index.....	2
Description du produit.....	3
Versions de contacts.....	4
Dimensions boîtier SUB-D.....	5
Équipements anti EMI / RFI.....	6
Perçage des cartes C.I.....	7 y 8
Dimensions conseillés.....	9 y 10
Schémas de montage avec équerres plastiques.....	11
Schémas de montage avec équerres métalliques.....	12
Connecteurs coudés montés avec équerres.....	13
Outils pour contacts à sertir.....	14
Désignation commerciale.....	15 y 16
Capots.....	17 y 18
Capots C-CE.....	19
Capots CT.....	20
Capots CTI.....	21
Accessoires.....	22
Capots prolongateurs.....	23
Capot CT 28 et capot pour câble plat.....	24
Désignation commerciale.....	25
Connecteur à double entrée à sortie coudée.....	26
Perçage des cartes C.I.....	27 y 28
Désignation commerciale.....	29 y 30

CARACTERISTICAS DE LOS CONECTORES D-SUBMINIATURA

Materiales:

Carcasas metálicas: fleje de acero bicromatado o niquelado.

Aislantes:

Monobloc
Termoplástico auto-extinguible
UL 94 VO

Modelos = 9-15-25-37-50 contactos

Contactos:

Mecanizado
Aleación de cobre.

Acabados:

Estandar = flash de oro sobre 2 µm de Ni
Clase 2 = 0,4 Au sobre 2µm de Ni
Clase 1 = 0,8 Au sobre 2µm de Ni

Retención contactos:

Nuestra tecnología permite extraer fácilmente cualquier tipo de contacto (Z,X,W3, Y, YC)

Datos técnicos:

Intensidad nominal: 5 Amp.
Intensidad nominal por contacto: 7.5 Amp.
Resistencia de contacto: ≤ 5 m Ω
Tensión de servicio: 250 Vac (r.m.s)
Tensión de ensayo a nivel del mar : 1.000 Vac (r.m.s)
Temperatura de utilización: -25°C a + 90°C
(Termoplástico) (HE 502)

Resistencia de aislamiento : ≥ 10¹⁰ M Ω
Según Norma UTC 93425 y MIL-C- 24.308

CHARACTERISTICS OF SUB-D CONNECTORS

Materials:

Metal shells : mild steel, yellow chromated or Nickel plated.

Connector mouldings:

Monobloc
Thermoplastic, self-extinguishing to UL 94 VO

Models = 9-15-25-37-50 contacts

Contacts:

Machine turned
Copper alloy

Plating:

Standard = gold flash over 2µm Ni
Class 2 = 0,4 Au over 2µm of Ni
Class 1 = 0.8 Au over 2µm of Ni

Contact retention:

All types of contact (Z, X, W3, Y, YC) can be easily extracted and replaced.

Technical data:

Working current: 5 Amp.
Working current per contact: 7,5 Amp.
Contact resistance: ≤ 5 m Ω
Working voltage: 250 Vac (r.m.s)
Test voltage at sea level: 1000 Vac (r.m.s)
Operating temperature: -25°C to + 90°C
(Thermoplastic) (HE 502)

Insulation resistance: ≥ 10¹⁰ M Ω
To Norm UTC 93425 and MIL-C-24.308.

CARACTÉRISTIQUES DES CONNECTEURS SUB-D

Matériaux:

Boîtiers en métal: tôle d'acier, Bichromaté ou Nickelé

Isolants:

Monobloc
Thermoplastique, autoextinguible
UL 94 VO

Modèles= 9-15-25-37-50 contacts.

Contacts:

Contacts de décolletage
laiton

Traitement de surface:

Standard = flash d'or sur 2µm Ni
Classe 2 = 0,4 Au sur 2µm Ni
Classe 1 = 0,8 Au sur 2µm Ni

Rétention des contacts:

Notre technologie propre offre la possibilité de démontage et remontage de tous les types de contact (Z, X, W3, Y, YC)

Caractéristiques techniques:

Intensité nominale: 5 Amp.
Intensité maxi par contact: 7,5 Amp.
Résistance de contact: ≤ 5 m Ω
Tension de service: 250 Vac (r.m.s).
Tension d'essai au niveau de la mer: 1.000 Vac (r.m.s)
Température d'utilisation: -25° C à + 90°C
(Thermoplastique) (HE 502)

Résistance D'isolement: ≥ 10¹⁰ M Ω
Selon Norme UTC 93425 et MIL-C-24.308

Contactos numerados en las dos caras del aislante.

Contact identification is made on both faces of moulding.

Contacts repérés sur les deux faces de l'isolant.

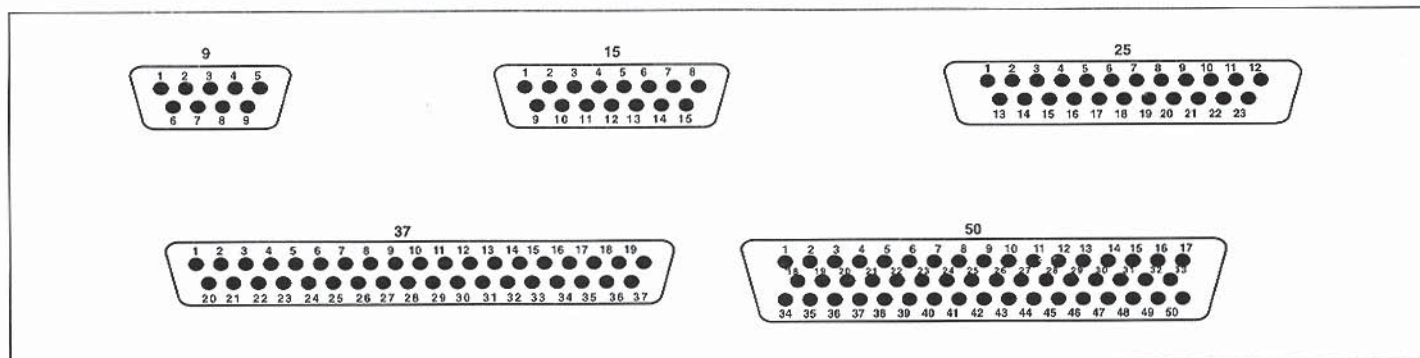

Tipo Type Type	Z	X	Y	Y1
Dimensiones contactos Contact dimensions Dimensions des contacts				
∅ Máx. cable mm. ∅ Max. wire mm. ∅ Max. câble mm.	AWG 20 1,1	AWG 20 1,1	---	---

Tipo Type Type	W3	YC	YC1
Dimensiones contactos Contact dimensions Dimensions des contacts		<p>Tipo estándar (-) Standard type (-) * = .112 Type standard (-) 2.84</p> <p>Tipo opcional (A) Optional type (A) * = .100 Type optionnel (A) 2.54</p>	
∅ Máx. cable mm. ∅ Max. wire mm. ∅ Max. cable mm.	---	---	---

Z = Contactos a soldar
Solder contacts
Contacts à souder

X = Contactos a pinzar montables y desmontables
Removable and replaceable crimp contacts
Contacts à sertir montables et démontables

Y = Contactos para C.I.
PCB contacts
Contacts pour C.I.

W3 = Contactos para mini wire-wrap 3
Miniature wire-wrap contacts 3
Contacts pour wire-wrap 3 enroulements

YC - YC1 = Contactos para C.I. salida acodada
Right-angled PCB contacts
Contacts pour C.I. sortie coudée

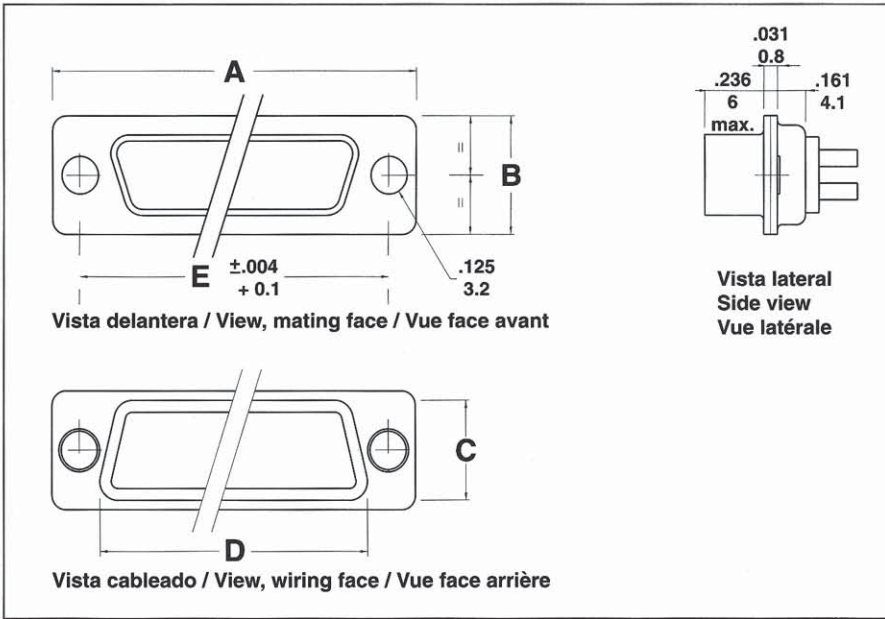

Fija: Para montaje sobre panel o para C.I.

Rigid: For panel or PCB mounting

Montage: Fixe sur panneau ou sur C.I.

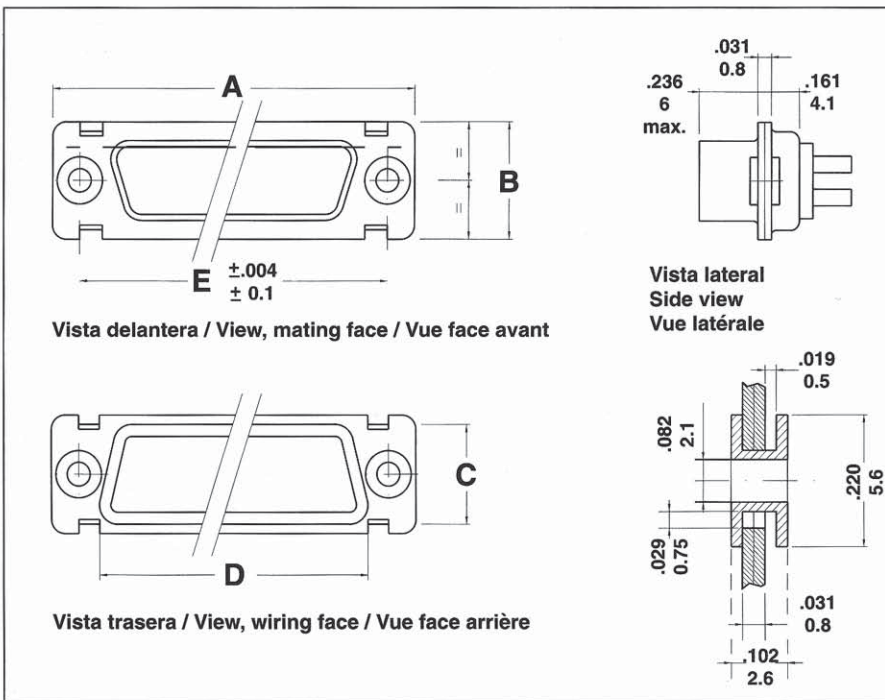

Flotante: Para montaje en rack

Floating: For rack mounting

Montage flottant: Pour montage en rack

Número de contactos Number of contacts Nombre de contacts	A max.		B max.		C max.		D max.		E $\pm .004$ ± 0.1	
9	1.224	31.1	.496	12.6	.437	11.1	.767	19.5	.984	25
15	1.551	39.4	.496	12.6	.437	11.1	1.095	27.8	1.311	33.3
25	2.094	53.2	.496	12.6	.437	11.1	1.634	41.5	1.850	47
37	2.744	69.7	.496	12.6	.437	11.1	2.283	58	2.500	63.5
50	2.650	67.3	.614	15.6	.547	13.9	2.189	55.6	2.405	61.1

Dimensiones en pulgadas y mm.
 Dimensions in inches and mm.
 Dimensions en pouces et mm.

Las interferencias electro-magnéticas (EMI) e interferencias radio-frecuencias (RFI) son términos empleados para definir una posible "degradación" en el rendimiento de transmisión de datos que pueda causar un funcionamiento deficiente del equipo electrónico.

Ofrecemos soluciones fáciles y sin complicaciones a los problemas EMI/RFI.

Una buena conexión en la continuidad de masa se consigue utilizando nuestro conector subminiatura D con dimples (muescas de continuidad de masa) asegurando un buen contacto entre el conector macho y el hembra.

Utilizando además nuestra caperuza metalizada, mejoramos esta continuidad al asegurar en todo el conjunto una excelente conexión.

Electro Magnetic Interference (EMI) and Radio Frequency Interference (RFI) are terms employed to define a possible degradation in performance through radiated fields of electronic equipment.

As a connector manufacturer we bring easy and non-complex solutions to EMI/RFI problems. A well grounded connection, using our D-subminiature connector with dimples to obtain a good contact between male and female, together with our metallized hood which provides a good termination to the shielded cable, offer a perfect solution to your engineering needs.

EMI - Interférence électro - magnétique

RFI - Interférence radio - fréquence sont des termes habituellement employés pour définir la possible dégradation du rendement de la transmission d'information.

Description du matériel:

Boîtier mâle: Nickelé avec languettes latérales prédécoupées.

Boîtier femelle: Nickelé . Assurant une bonne continuité de masse avec le boîtier mâle.

Capot: Métallisé afin d'assurer un excellent blindage.

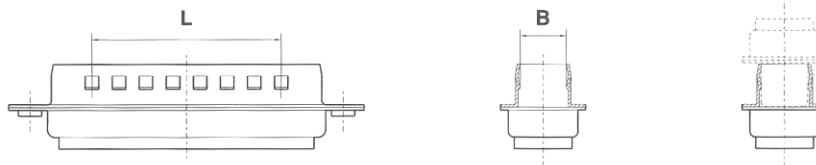

Número de contactos Number of contacts Nombre de contacts	L	B	Número de muescas Number of dimples Nombre de languettes
9	0.307 7.8	0.299 7.6	6
15	0.614 15.6	0.299 7.6	10
25	1.075 27.3	0.299 7.6	16
37	1.689 42.9	0.299 7.6	24
50	1.689 42.9	0.413 10.5	24

Acabado carcasa: Niquelado
Shell plating: Nickel plated
Finition boîtier: Nickelé

Dimensiones en pulgadas y mm.
Dimensions in inches and mm.
Dimensions en pouces et mm.

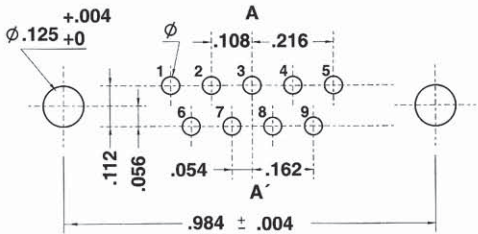

9 contactos
contacts
contacts

A Montaje para conector YC. Versión estándar.
Mounting for YC connector. Standard version.
Montage pour connecteur YC. Version standard.

A' Versión reverso.
Reverse version.
Version inversée

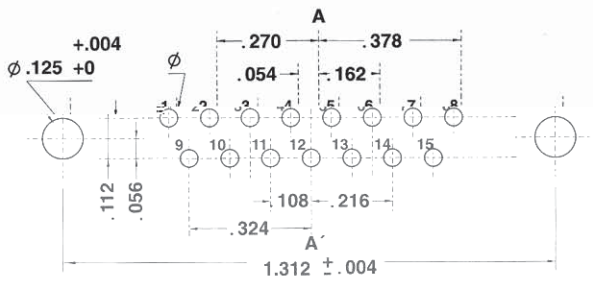

15 contactos
contacts
contacts

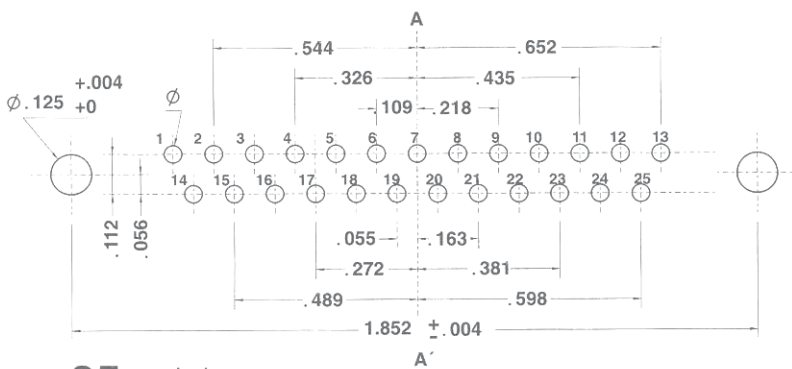

25 contactos
contacts
contacts

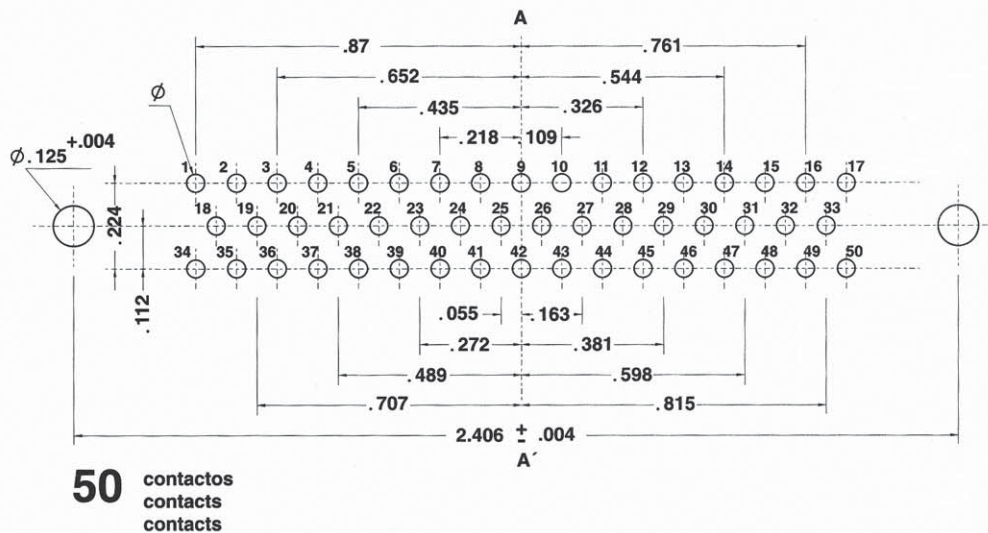
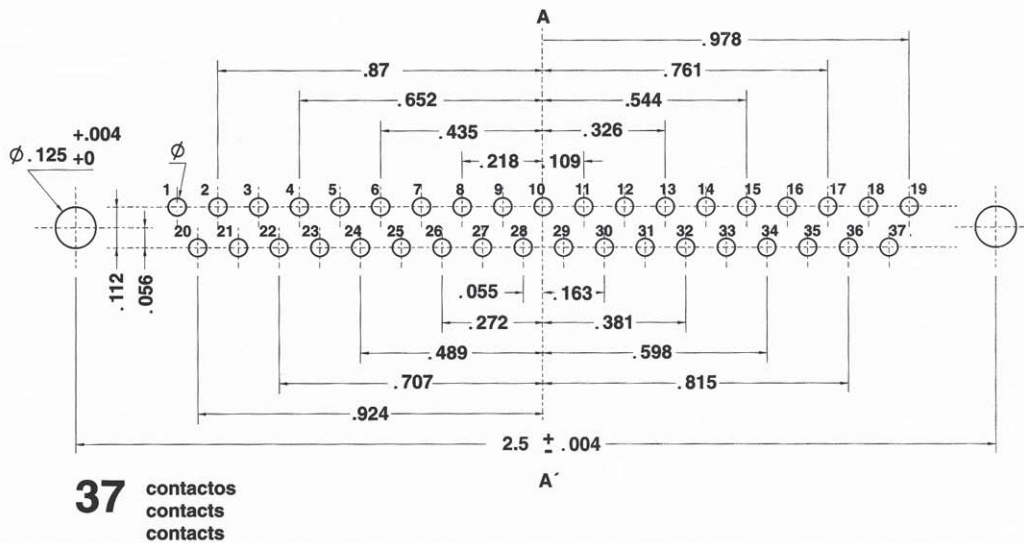

A-A' = Eje de referencia.
Las tolerancias de posicionamiento de los agujeros son de $\pm .004$ pulgadas / 0.1 mm.
 ϕ aconsejado: .031 a .039 pulgadas / 0.8 a 1 mm.
Clavija de .023 pulgadas / 0.6 mm.

A-A' = reference axis.
Positional tolerance of holes: $\pm .004$ inches / 0.1 mm.
Recommended ϕ : .031 to .039 inches / 0.8 to 1 mm.
Diameter of contact terminations .023 inches / 0.6 mm.

A-A' = Axe de référence.
Les tolérances de positionnement des perçages sont de $\pm .004$ pouces / 0.1 mm.
 ϕ de perçage conseillé: .031 a .039 pouces / 0.8 à 1 mm.
Pour sortie de contact: .023 pouces / 0.6 mm.

TABLA CONVERSION DE PULGADAS A MILIMETROS / CONVERSION CHART - INCHES TO MILIMETRES / TABLEAU DE CONVERSION DE POUCHES EN MILLIMETRES.

.004	0.1	.054	1.37	.055	1.40	.056	1.42	.108	2.74	.109	2.77	.112	2.84
.125	3.2	.162	4.11	.163	4.14	.216	5.49	.218	5.54	.224	5.68	.270	6.86
.272	6.91	.324	8.23	.326	8.28	.378	9.60	.381	9.68	.435	11.05	.489	12.42
.544	13.82	.598	15.19	.652	16.56	.707	17.96	.761	19.33	.810	22.10	.815	20.70
.924	23.47	.978	24.84	.984	25	1.312	33.3	1.852	47	2.406	61.1	2.5	63.5

Dimensiones en pulgadas y mm.
Dimensions in inches and mm.
Dimensions en pouces et mm.

Dimensiones aconsejadas de los orificios para el montaje en panel exterior.
Recommended dimensions of cutouts on exterior panel.
Dimensions conseillées des ouvertures sur panneau extérieur.

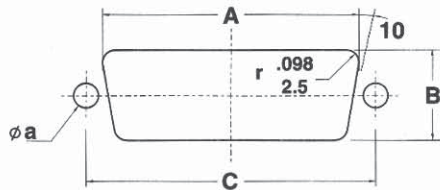

Montaje trasero.
Rear mounting.
Montage arrière.

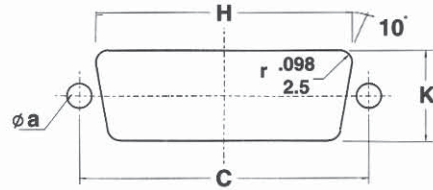

Montaje delantero.
Front mounting.
Montage avant.

N. de contactos N. of contacts N. de contacts	Tipo de montaje Type of mounting Type de montage	ϕa		A		B		C		H		K	
		$\pm .004$	± 0.1	$\pm .004$	± 0.1	$\pm .004$	± 0.1	$\pm .004$	± 0.1	$\pm .004$	± 0.1	$\pm .004$	± 0.1
9	FL	.082	2.10	.744	18.90	.405	10.30	.985	25	.815	20.70	.476	12.10
	R	.125	3.20										
15	FL	.082	2.10	1.070	27.20	.405	10.30	1.311	33.30	1.141	29	.476	12.10
	R	.125	3.20										
25	FL	.082	2.10	1.610	40.90	.405	10.30	1.850	47	1.681	42.70	.476	12.10
	R	.125	3.20										
37	FL	.082	2.10	2.260	57.40	.405	10.30	2.500	63.50	2.330	59.20	.476	12.10
	R	.125	3.20										
50	FL	.082	2.10	2.165	55	.520	13	2.405	61.10	2.244	57	.595	15.10
	R	.125	3.20										

R= Rígido - Rigid - Rigide/ FL= Flotante - Floating - Flottant

Montaje rígido estándar. 2 tornillos de diam. .118 pulgadas/3 mm.
Standard rigid mounting. 2 screws, diam. .118 inches/3 mm.
Montage rigide. 2 vis de diam. .118 pouces/3 mm.

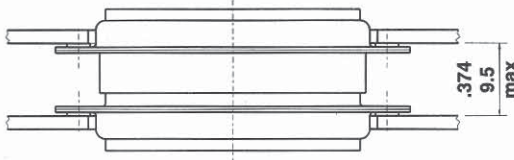

Montaje delantero
Front mounting
Montage avant

Montaje flotante mixto. 2 tornillos de diam. .078 pulgadas/2 mm.
Mixed floating mounting. 2 screws, diam. .078 inches/2 mm.
Montage flottant mixte. 2 vis de diam. .078 pouces/2 mm.

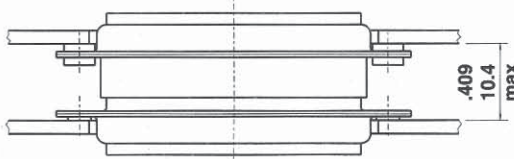

Montaje delantero
Front mounting
Montage avant

Dimensiones en pulgadas y mm.
Dimensions in inches and mm.
Dimensions en pouces et mm.

Conector para C.I. con salidas acodadas (YC)
90° PC board connector (YC)
Connecteur pour C.I. sorties coudées (YC)

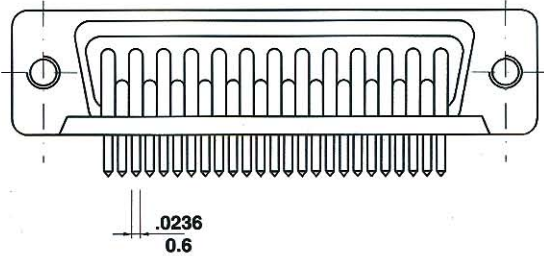

Montado sobre C.I.
Mounted on circuit board
Montage sur C.I.

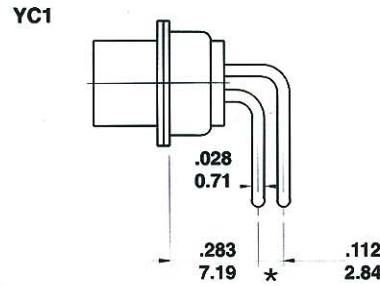
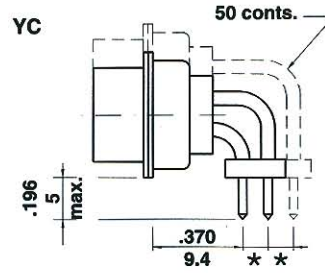

Tipo estándar (-)
Standard type (-) * = .112
Type standard (-) 2.84

Tipo opcional (A)
Optional type (A) * = .100
Type optionnel (A) 2.54

Dimensiones en pulgadas y mm.
Dimensions in inches and mm.
Dimensions en pouces et mm.

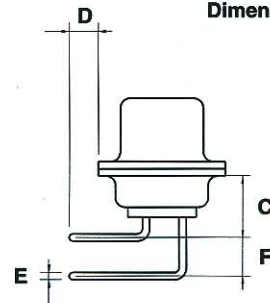
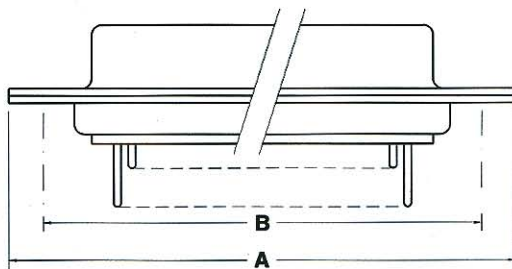

conts.	A		B		C		D		E		F	
	YC	YC1	YC	YC1	YC	YC1	YC	YC1	YC	YC1	YC	YC1
9	1.22 31.1	1.21 30.8	.984 25	.984 25	.370 9.4	.283 7.19	.175 4.47	.120 3.07	.24 0.60	.27 0.71	.111 2.84	.111 2.84
15	1.53 39.1	1.53 39.1	1.31 33.3	1.31 33.3	.370 9.4	.283 7.19	.175 4.47	.120 3.07	.24 0.60	.27 0.71	.111 2.84	.111 2.84
25	2.09 53.2	2.08 52.9	1.85 47	1.85 47	.370 9.4	.283 7.19	.175 4.47	.120 3.07	.24 0.60	.27 0.71	.111 2.84	.111 2.84
37	2.73 69.4	2.73 69.4	2.5 63.5	2.5 63.5	.370 9.4	.283 7.19	.175 4.47	.120 3.07	.24 0.60	.27 0.71	.111 2.84	.111 2.84
50	2.63 67	2.63 67	2.40 61.1	2.40 61.1	.370 9.4	.283 7.19	.175 4.47	.120 3.07	.24 0.60	.27 0.71	.111 2.84	.111 2.84

Dimensiones
Dimensions
Dimensions

Dimensiones en pulgadas y mm.
Dimensions in inches and mm.
Dimensions en pouces et mm.



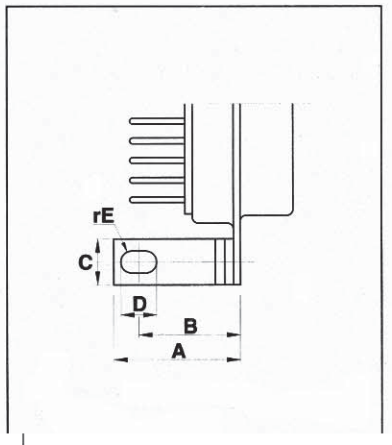
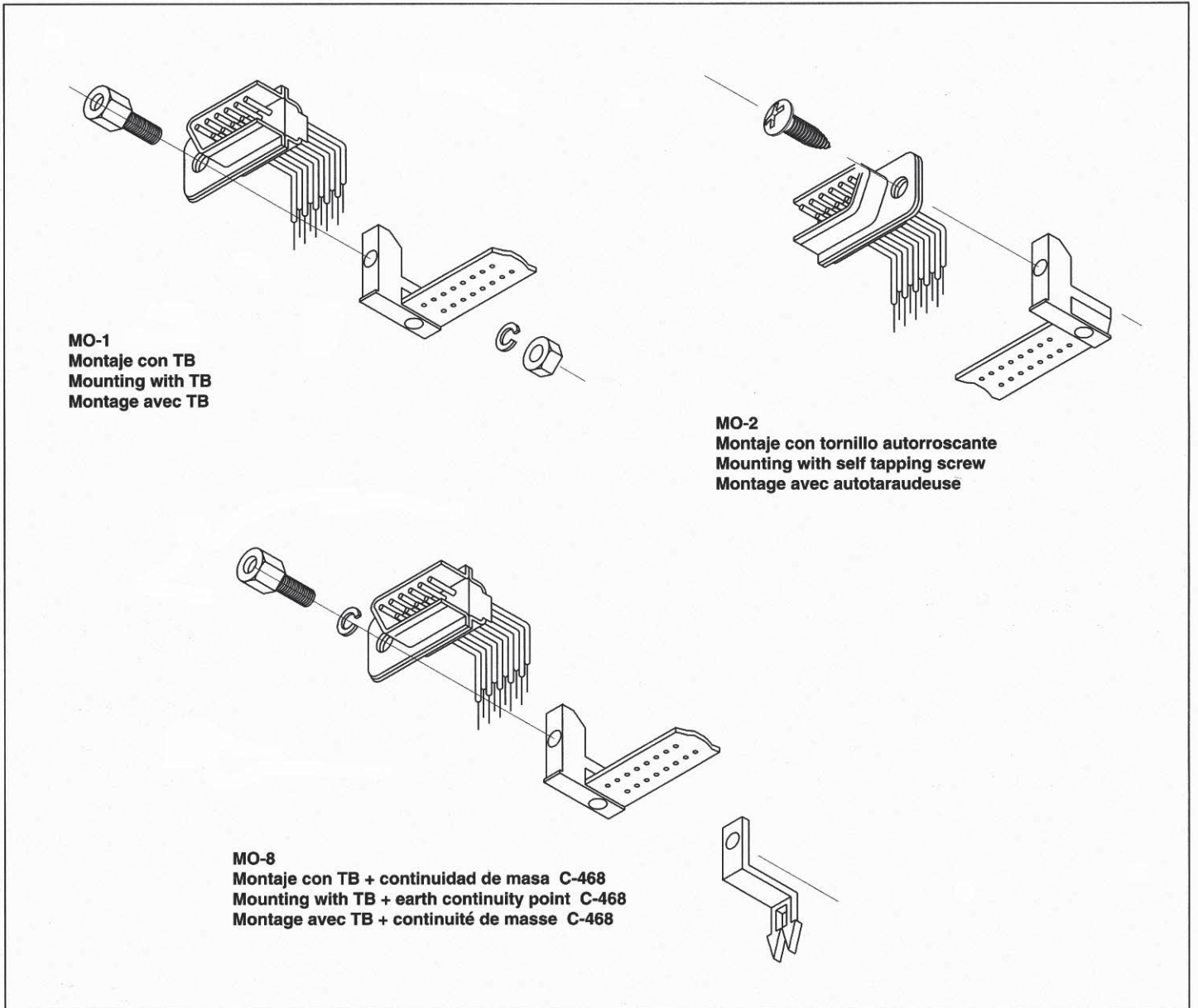

ESCUADRAS DE PLASTICO PLASTIC BRACKETS ÉQUERRES PLASTIQUES														
YC (9, 15, 25, 37)					YC1 (9,15, 25, 37)					YC (50)				
A	B	C	D	rE	A	B	C	D	rE	A	B	C	D	rE
15.2	11.3	5	3.6	1.6	16	10.3	5	5.2	1.6	15.2	11.3	5	3.6	1.6
Ref. C - 324 C - 419 Autorroscante Self Tapping Autotaraudeuse					C - 560					C - 325 C - 420 Autorroscante Self Tapping Autotaraudeuse				

Dimensiones en mm.
Dimensions in mm.
Dimensions en mm.

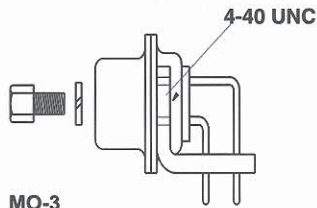

MO-3
Escuadra metálica roscada con TB 25
Threaded bracket with TB 25
Équerre fileté avec TB 25

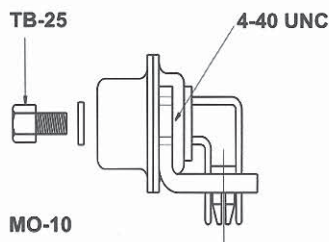

MO-10
Escuadra roscada con TB 25 y con continuidad de masa.
Threaded bracket with TB 25 and earth continuity point.
Équerre fileté avec TB 25 et continuité de masse.

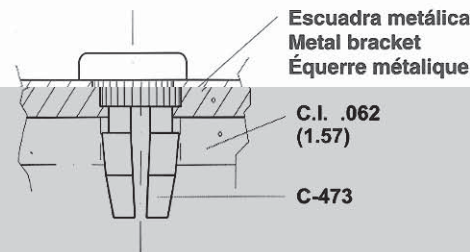

Escuadra metálica
Metal bracket
Équerre métallique

C.I. .062
(1.57)

C-473

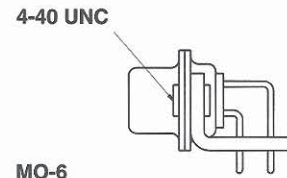

MO-6
Escuadra roscada y remachada al conector.
Montaje en fábrica

Threaded bracket, riveted to the connector.
Factory assembled

Équerre fileté et riveté au connecteur.
Montage en usine

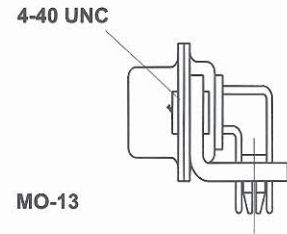

MO-13
Escuadra roscada y remachada al conector con
continuidad de masa. Montaje en fábrica

Threaded bracket riveted to the connector with
earth continuity point. Factory assembled

Équerre fileté et riveté au connecteur et
continuité de masse. Montage en usine

Dimensiones en pulgadas y mm.
Dimensions in inches and mm.
Dimensions en pouces et mm.

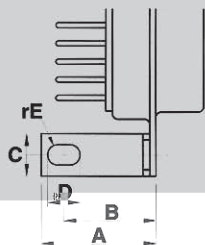

ESCUADRAS METALICAS MONTADAS
MOUNTED METAL BRACKETS
ÉQUERRES METALLIQUES ASSEMBLÉES

YC (9, 15, 25, 37)					YC1 (9, 15, 25, 37)				
A	B	C	D	rE	A	B	C	D	rE
15	11.8	5.6	4.7	1.6	14.1	9.7	4.7	1.6	
Ref. C - 430					C - 374				

Dimensiones en mm.
Dimensions in mm.
Dimensions en mm.

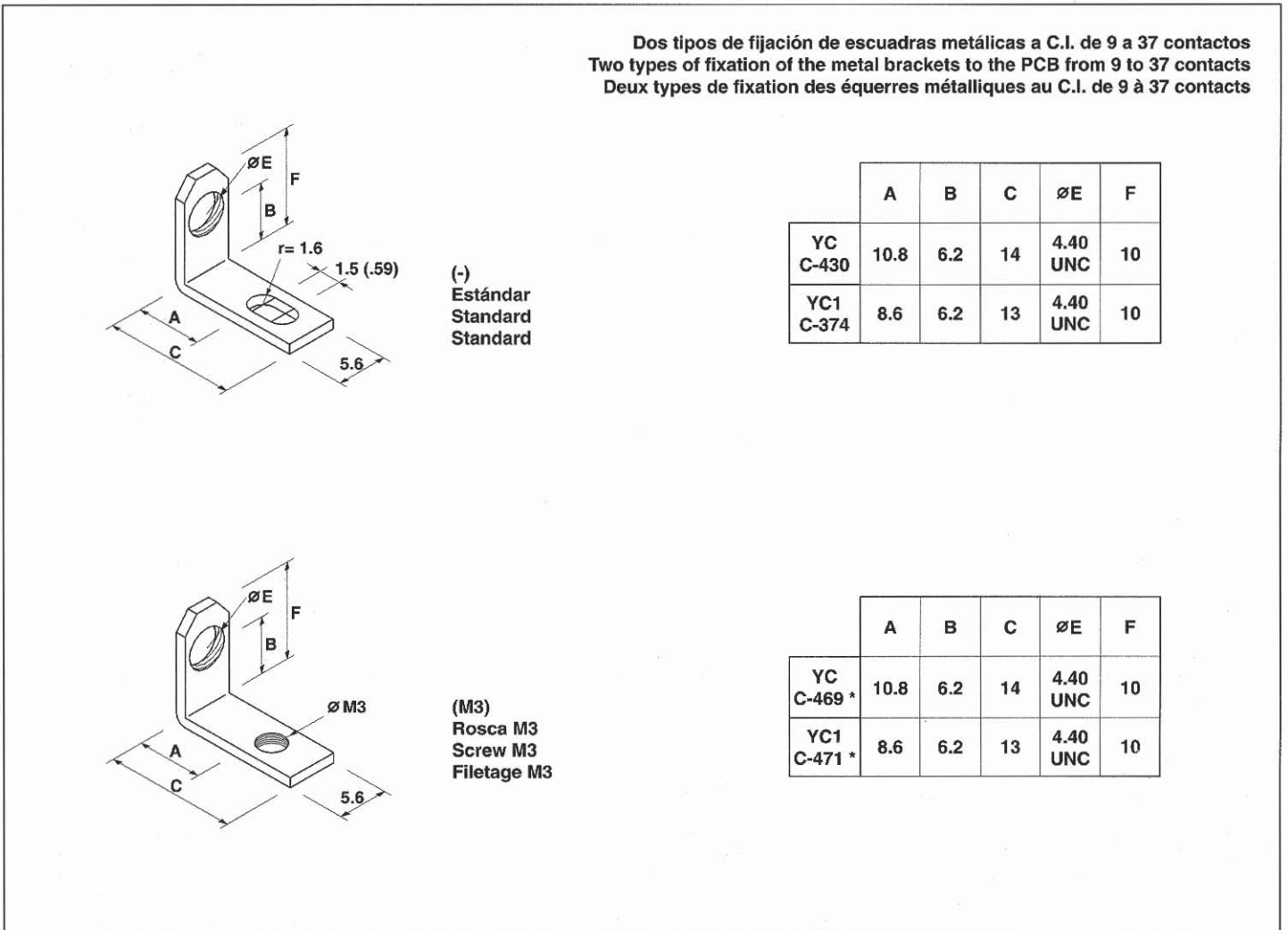
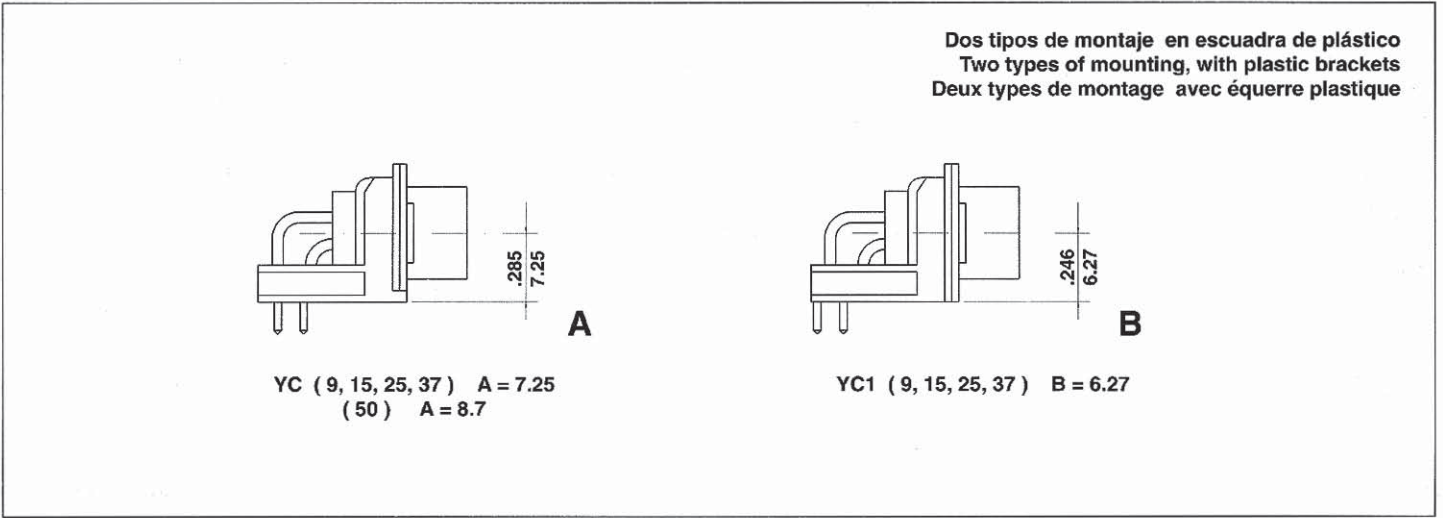

Ver pág. 16 para información de cómo solicitar los productos
See pg. 16 for ordering information
Voir pg. 16 pour comment commander les produits

* Bajo demanda / On request / Sur demande

Dimensiones en pulgadas y mm.
Dimensions in inches and mm.
Dimensions en pouces et mm.

Referencias de contactos a pinzar tipo X (montables y desmontables):

Ref.: contactos macho PX C-12

Ref.: contactos hembra SX C-10

Galgas de cable a pinzar AWG máx. 20

Copeta a pinzar de acuerdo con MS 18281

Pinza para remachar según Norma MIL-T-22520

Type X crimp contacts (insertable and removable) part numbers:

Ref.: male contacts PX C-12

Ref.: female contacts SX C-10

Gauge for crimping wire sizes 20 AWG max.

Crimp bucket in accordance with MS 18281

Crimp tools conform to MIL-T-22520





Réf.: Contacts mâles PX C-12

Réf.: Contacts femelles SX C-10

Jauge AWG max. 20

Coupelle à sertir conforme à MS 18281

Pince à sertir suivant Norme MIL-T-22520

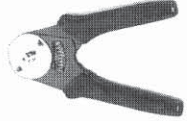
Ref. 701	<p>Util de inserción de los contactos macho y hembra Cable máx. a utilizar con recubrimiento exterior ϕ .049 (1.25) Installing tool for male and female contacts Maximum cable to be used including insulation ϕ .049 (1.25) Outil d'insertion mâle/femelle Capacité max. gaine du câble: ϕ .049 (1.25)</p>	
Ref. 702/3	<p>Util de extracción con la punta recambiable de los contactos macho y hembra Removal tool with replaceable head for male and female contacts Outil d'extraction à pointe de rechange mâle/ femelle</p>	
Ref. C-202	<p>Punta recambiable para útil 702/3 Replacement head for tool Ref. 702/3 Pointe de rechange pour Réf. 702/3</p>	<p>Para macho For male pour mâle</p>  <p>Para hembra For female pour femelle</p>
Ref. AFM 8	<p>Útil a pinzar regulable con posicionador para cable de galga AWG Adjustable crimp tool with positioner for wire AWG gauges Pince à sertir avec positionneur réglable pour jauge AWG</p>	
Ref. K 613	<p>Accesorio posicionador para pinzas AFM 8 para colocación del contacto Positioner for tool AFM 8 to assure correct contact location Positionneur pour pince Ref. AFM 8</p>	
Ref. Ht1440	<p>Pinza fija para fijación del cable AWG 20 al contacto Crimp tool for wire gauge 20 AWG Pince à sertir non réglable pour jauge AWG 20</p>	

Instrucciones para el montaje de contactos a pinzar

Pelado del cable

Cortar el aislante del cable a 4 mm. (.157)

Pinzado de los contactos

Coloque el contacto a pinzar (SX C-10 ó PX C-12) en el útil y ponga el cable con el aislante cortado en la copeta del contacto. Apriete la tenaza al máximo hasta que se vuelva a abrir y la operación de pinzado quedará realizada.

Assembly instructions for crimp contacts

Wire stripping

Strip cable insulation to 4 mm. (.157)

Contact crimping

Insert crimp contact (SX C-10 or PX C-12) into the tool and push stripped cable into the contact bucket. Close the crimp tool fully. The tool will only release when the crimp is completed.

Instructions pour le sertissage

Dénudage du câble.

Couper l'isolant du câble à 4 mm. (.157)

Sertissage des contacts

Placer le contact (SX C-10 ou PX C-12) dans le logement du positionneur. Placer ensuite le câble préalablement dénudé dans la coupelle du contact. Effectuer le serrage de la pince à fond de telle manière que la pince puisse s'ouvrir à nouveau (sécurité de sertissage).

CONECTORES ESTANDAR / STANDARD CONNECTORS / CONNECTEURS STANDARD

SD	N	F	T	25	P	Z	-
Serie / Series / Série							
SD Serie D / SD series D / SD série D							
Aislante / Insulator / Isolant							
(N) Termoplástico / Thermoplastic / Thermoplastique							
Montaje / Mounting / Montage							
(-) Rígido / Rigid / Fixe (F) Flotante / Floating / Flottant							
Carcasa / Shell / Boîtier							
(-) Estándar / Standard / Standard (T) Niquelado / Nickel plated / Nickelé (D) Dimple / Dimples / Dimple							
Número de contactos / Number of contacts / Nombre de contacts (9,15,25,37,50)							
Ref. contactos / Contact designation / Réf. contacts							
(P) Macho / Male / Mâle (S) Hembra / Female / Femelle							
Tipo de contactos / Contact type / Type des contacts							
(X) A pinzar / Crimp / À sertir				(Y, Y1) Para C.I. (recto) / Straight PCB / Pour C.I. (droit)			
(Z) A soldar / Solder / À souder				(YC, YC1) Para C.I. (acodado) / 90° PCB / Pour C.I. (coudé)			
(W3) Para wire-wrap / Wire wrap / Pour wire wrap							
(X) Contactos a pedir por separado (Pág. 14) Contacts to be ordered separately (Pg. 14) À commander séparément (Pg. 14)				(YC)(YC1) Ver información adicional (Pág.16) See additional information (Pg. 16) Voir information additionnelle (Pg. 16)			
Montajes especiales / Special mountings / Montages sur demande							

Nota: (-) No indicar

Note: (-) Omit

Note: (-) Ne rien indiquer

CONECTORES ACODADOS / RIGHT ANGLED CONNECTORS / CONNECTEURS COUDÉS

SD N F T 25 P

YC

R

A

MO-1

M3

B

Tipo de contactos / Contact type / Type des contacts**Posición de los contactos / Contact orientation / Position des contacts**

- (-) Estándar (sobre el C.I.) / Standard (on circuit board) / Standard (sur C.I.)
 (R) Contactos invertidos / Inverted contacts / Contacts inversés

Distancia entre filas de contactos del C.I. / Distance between PC board rows / Distance entre files des contacts du C.I.

- (-) Estándar .112 (2.84) / Standard .112 (2.84) / Standard .112 (2.84)
 (A) .100 (2.54)

Accesorios de montaje / Mounting accessories / Accessoires de montage

- (- Sin accesorios / Without accessories / Sans accessoires
 (MO-1) Escuadras de plástico con TB / Plastic brackets with TB / Équerres plastiques avec TB
 (MO-2) Escuadras de plástico con tornillo autorroscante / Plastic brackets with self tapping screw / Équerres plastiques à vis autotaraudeuse
 (MO-3) Escuadras metálicas con TB / Metal brackets with TB / Équerres métalliques avec TB
 (MO-6) Montaje con escuadras metálicas remachadas al conector con casquillo rosca interior 4-40 UNC / Mounting with right angled metal brackets riveted to connector with interior 4-40 UNC thread / Montage avec équerres métalliques serties sur boîtier avec trou taraudé 4-40 UNC
 (MO-8) Escuadras de plástico con TB con continuidad masa / Plastic brackets with TB and earth continuity clip / Équerres plastiques avec TB et continuité de masse
 (MO-10) Escuadras metálicas con TB y continuidad masa / Metal brackets with TB and earth continuity clip / Équerres métalliques avec TB et continuité de masse
 (MO-13) Montaje con escuadras metálicas remachadas al conector con casquillo rosca interior 4-40 UNC y con continuidad masa / Mounting with right angled metal brackets riveted to connector with interior 4-40 UNC thread and earth continuity clip / Montage avec équerres métalliques serties sur boîtier avec trou taraudé 4-40 UNC et continuité de masse

Para otros montajes consultar / Other mountings on request / Autres montages sur demande

Taladro fijación a C.I. (con escuadra metálica) / Hole fixation to C.I. (only metal bracket) / Perforation fixation au C.I. (équerre métallique uniquement)

- (-) Estándar / Standard / Standard
 (M3) Rosca M3 / M3 Thread / Filetage M3

Altura conector/ Connector height/ Hauteur connecteur

Sólo para escuadras de plástico, ver pág. 13
 Only for for plastic brackets, see pg. 13
 Seulement pour équerres plastiques, voir pg. 13

Nota: (-) No indicar
 Note: (-) Omit
 Note: (-) Ne rien indiquer

Nuestras caperuzas están compuestas de dos medios cuerpos para el fácil montaje de los conectores y sujetos por dos tornillos, lo que les confiere gran resistencia.

Los cables son retenidos por dos semi bridas en todos los modelos a excepción de la versión CTI que comporta una sola brida interior.

Ofrecemos dos tipos de enclavamientos:

De seguridad (C-CE)

CE: Su enclavamiento se efectúa por cierre deslizante, lo que permite conectar caperuza/caperuza o caperuza/panel.

Su enclavamiento es muy rápido e imposible de desenclavar si no se hace voluntariamente.

Especialmente diseñado para todas aquellas aplicaciones en las que el enclavamiento precise de gran seguridad y espacio difícil de acceder.

C: Tienen las mismas dimensiones que la caperuza CE, pero sin elemento de fijación.

Standard (CT-CTI-CTF)

Su enclavamiento se efectúa mediante dos tornillos imperdibles, sea entre caperuza/caperuza o caperuza/panel, mediante tuerca hembra TB.

Todas las caperuzas se pueden metalizar para solucionar el problema de EMI/RFI, son compatibles con todos los conectores Sub-miniatura D que sean conformes a la Norma MIL-C-24308.

Características

Carcasas: Termoplástico auto-extinguible UL 94 VO, color negro o metalizado (níquelado).

Partes metálicas: De acero tratado.

Our hoods consist of two half shells, making it easy to mount the connectors. They are secured by two screws and are very resistant. All models contain two half cable clamps except for the CTI version which has only one interior clamp.

We offer two different locking systems:

Secure system (C-CE)

CE: Quick release slide-lock locking system. We can connect hood to hood and hood to panel. This locking system is very fast and impossible to release unless done voluntarily.

It was designed for all applications in which the locking system needs to be particularly secure and in areas which are difficult to access.

C: The same dimensions as the CE hood but without the locking element.

Standard (CT-CTI-CTF)

Hoods with a standard jackscrew locking system between hoods (or hood) and rack panel by a TB jackpost.

All the hoods can be metallized to help solve EMI/RFI problems and are compatible with all D-Sub connectors conforming to MIL-C-24308.

Technical data

Shell: Self-extinguishing Thermoplastic to UL 94 VO, black or metallized (nickel plated).

Metal parts: Nickel plated steel.

Nos capots sont composés de deux parties pour le facile montage des connecteurs.

Le montage s'effectue avec deux vis qui le rend très résistant.

Tous les modèles ont deux semi brides à l'exception de la version CTI qui ne contient qu'une bride intérieure.

Nous offrons deux types de verrouillage:

De sécurité (C-CE)

CE: Capot avec verrouillage rapide qui permet de connecter capot à capot ou capot à panneau. Impossible de déverrouiller involontairement.

Spécialement indiqué pour toute application où on précise d'une grande sécurité ou manque d'espace.

C: Les mêmes dimensions que pour le capot CE mais sans élément de fixation.

Standard (CT-CTI-CTF)

Système standard de verrouillage avec deux vis imperdables entre capot/ capot ou capot/panneau.

Tous les capots peuvent être livrés en version métallisé pour résoudre les problèmes de EMI / RFI et ils sont compatibles avec les connecteurs conformes à la norme MIL-C-24308.

Description du matériel:

Boîtier : Thermoplastique norme UL 94 VO, noir ou métallisé (nickelé).

Parties métalliques: Acier nickelé.

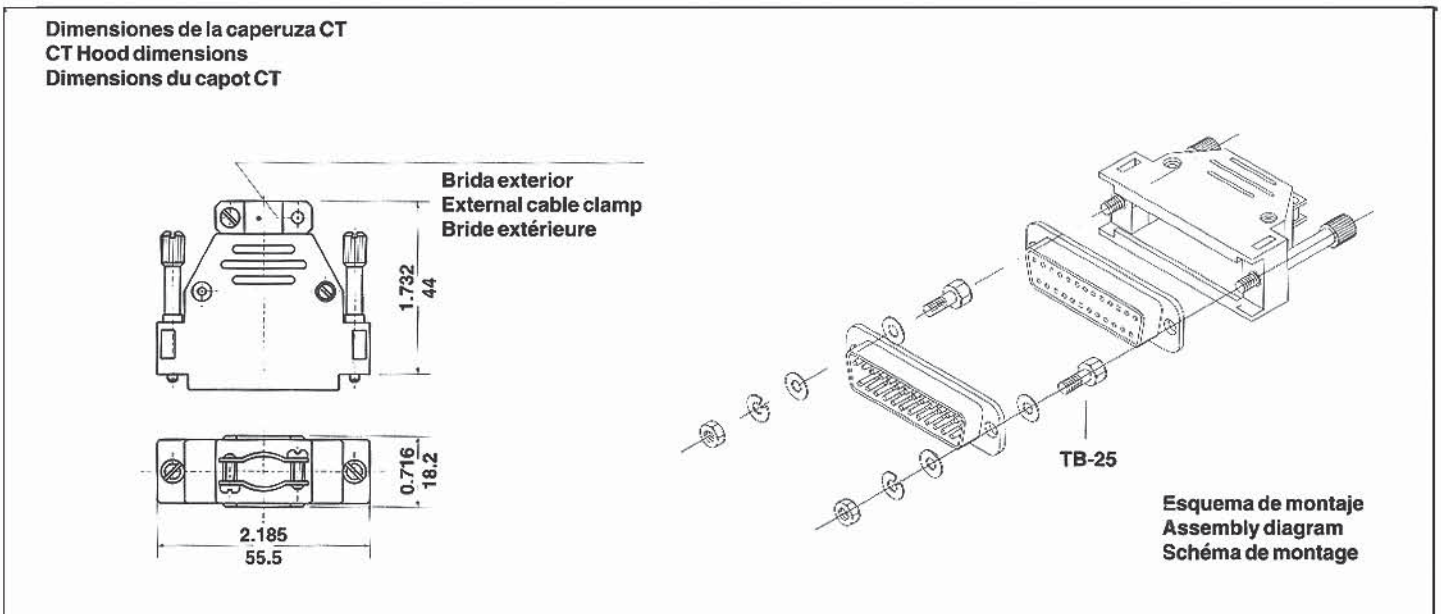

Dimensiones en pulgadas y mm.
Dimensions in inches and mm.
Dimensions en pouces et mm.

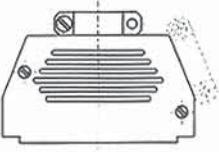
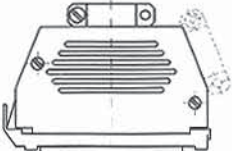
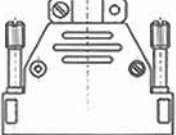
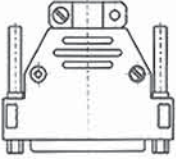
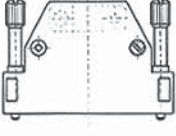
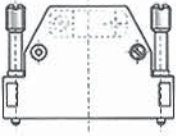
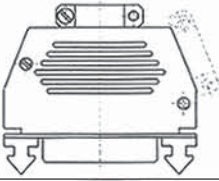
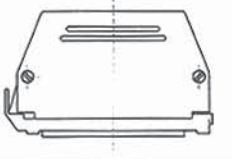
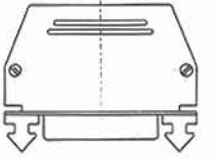
	Caperuzas/Hoods/Capots						Fijación / Locking Systems / Fixation					
	Ref.	9	15	25	37	50	9	15	25	37	50	
	C	X	X	X	X	X	---	---	---	---	---	
	CE	X	X	X	X	X	FBF-S FBF-I	X	X	X	X	FB-50
	CT	X	X	X	X	X		TB-25 *	X	X	X	X
	PCT Prolongador Extender Prolongateur	X	X	X	X	X	CT	X	X	X		X
	CTI Brida fija Fixed clamp Bride fixe	X	X	X	---	---	TB-25 *	X	X	X	---	---
	CTF PCTF Brida flotante Floating clamp Bride flottante	---	---	---	---	X	TB-25 *	---	---	---	---	X
	PCE Prolongador Extender Prolongateur	X	X	X	X	X	CE	X	X	X	X	X
	CP CPE Cable plano Flat cable Câble plat	---	---	X	---	---	FBF-S FBF-I	---	---	X	---	---
	PCPE Prolongador Extender Prolongateur	---	---	X	---	---		CE CPE	---	---	X	---

* Otras TB bajo demanda / Other TB on request / Autres TB sur demande



CAPERUZAS C - CE
C - CE HOODS
CAPOTS C - CE

Dimensiones de la caperuza
 Hood dimensions
 Dimensions du capot

Esquema de montaje
 Assembly diagram
 Schéma de montage

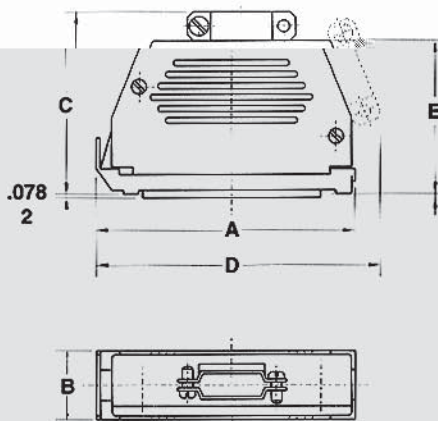

Trinquetes FBF-S
 FBF-S Latch
 Crochet FBF-S

Resorte
 Spring
 Ressort

Brida
 Câblé
 Clamp

Corredera FF
 Slider FF
 Glissière FF

C: sin enclavamiento
 CE: con enclavamiento

C: w/out locking system
 CE: with locking system

C: sans système de fixation
 CE: avec système de fixation

Número de contactos Number of contacts Nombre de contacts	Caperuza CE CE Hood Capot CE									
	A		B		C		D		E	
9	1.456	37	.590	15	1.338	34	1.692	43	1.083	27.5
15	1.771	45	.590	15	1.574	40	2.086	53	1.260	32.0
25	2.362	60	.590	15	1.732	44	2.677	68	1.437	36.5
37	3.032	77	.590	15	2.047	52	3.307	84	1.732	44.0
50	2.913	74	.708	18	2.047	52	3.189	81	1.732	44.0

**CAPERUZAS CT
CT HOODS
CAPOTS CT**

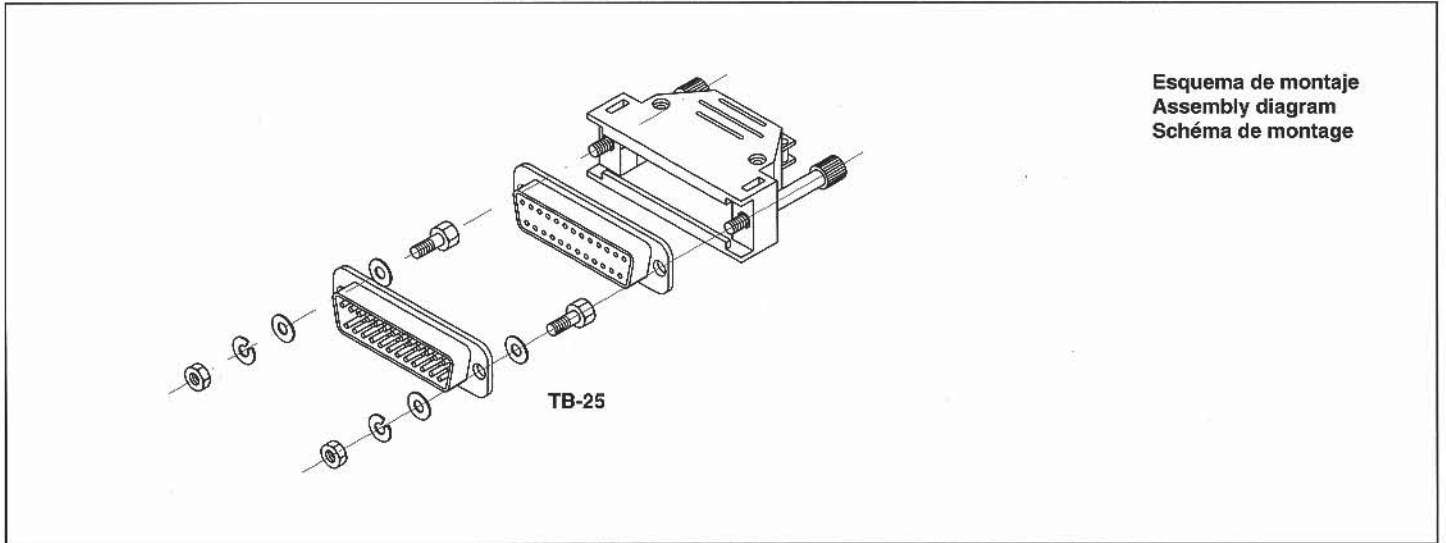

Número de contactos Number of contacts Nombre de contacts	A		B		C	
9	1.240	31.5	1.200	30.5	.716	18.2
15	1.653	42.0	1.700	43.2	.472	18.2
25	2.185	55.5	1.732	44.0	.716	18.2
37	2.834	72.0	1.811	46.0	.716	18.2
50	2.637	67.0	1.811	46.0	.846	21.5

Dimensiones de la caperuza CT
CT Hood dimensions
Dimensions du capot CT

Dimensiones en pulgadas y mm.
Dimensions in inches and mm.
Dimensions en pouces et mm.

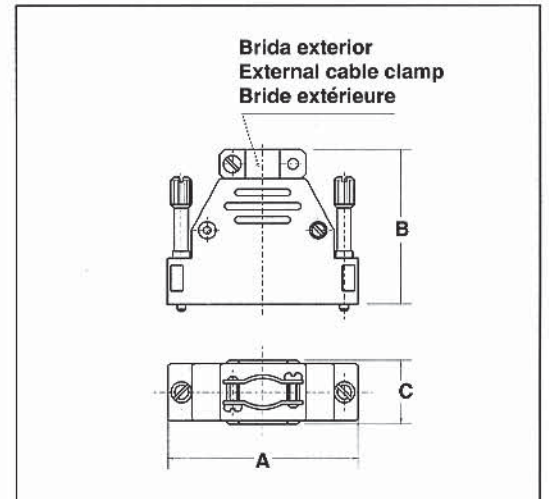

Número de contactos Number of contacts Nombre de contacts	Salida de cable para CT-CE External cable outlet for CT-CE Sortie câble pour CT-CE							
	Brida redonda Round cable clamp Bride ronde				Brida rectangular Rectangular cable clamp Bride rectangulaire			
	máx.		min.		máx.		min.	
9	.236	6	.157	4	---	---	---	---
15	.275	7	.196	5	---	---	---	---
25	.315	8	.236	6	---	---	---	---
37	---	---	---	---	.275x.630	7x16	.196x.630	5x16
50	---	---	---	---	.393x.630	10x16	.196x.630	5x16

Dimensiones en pulgadas y mm.
Dimensions in inches and mm.
Dimensions en pouces et mm.

*Otras TB bajo demanda / Other TB on request / Autres TB sur demande



CAPERUZAS CTI
CTI HOODS
CAPOTS CTI

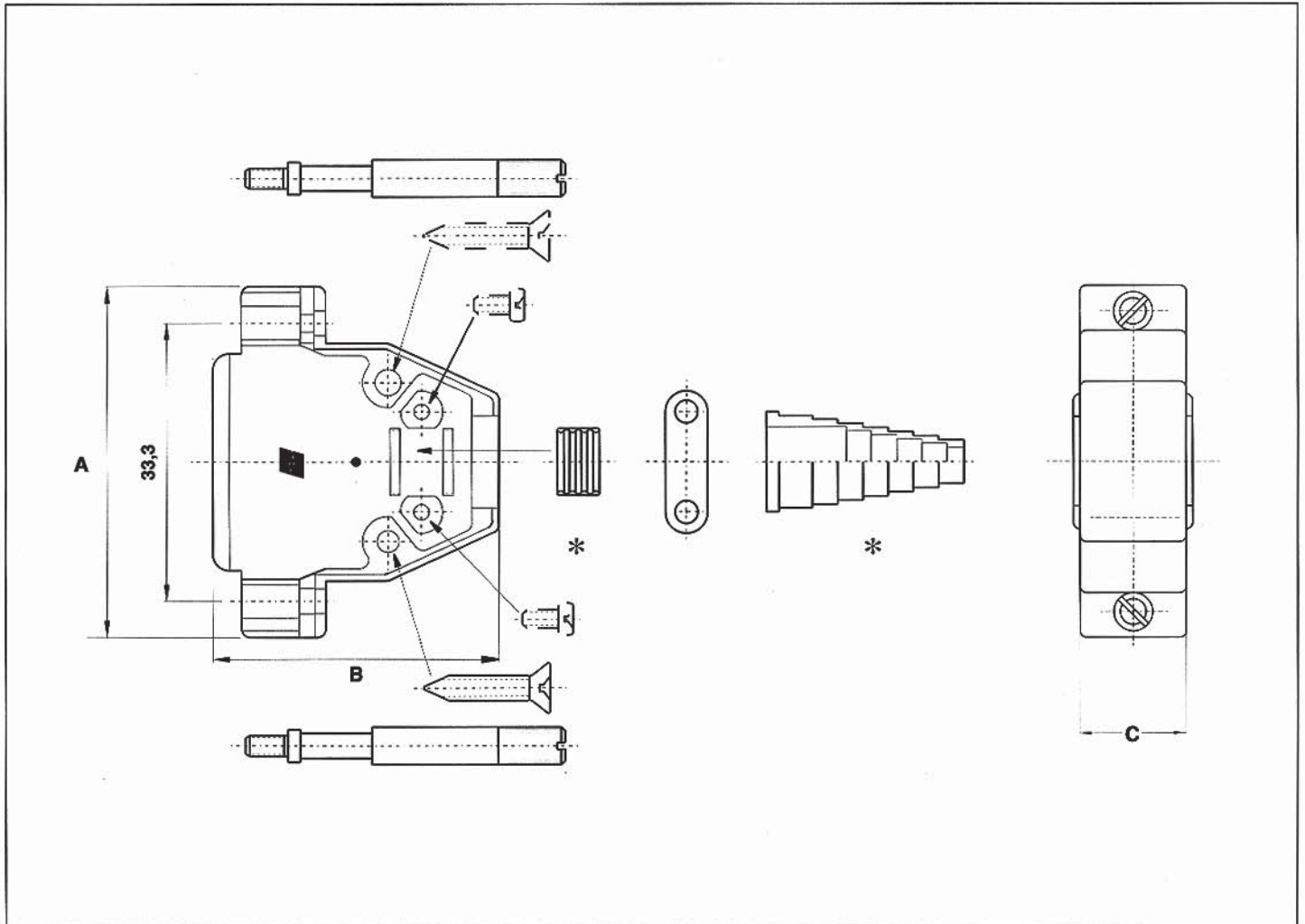

* Sólo para CTI-15. En preparación CTI-9 y CTI-25
 * Only for CTI-15. CTI-9 and CTI-25 in preparation
 * Seulement pour CTI-15. CTI-9 et CTI-25 en préparation

Dimensiones en pulgadas y mm.
 Dimensions in inches and mm.
 Dimensions en pouces et mm.

Número de contactos Number of contacts Nombre de contacts	A		B		C		Número de contactos Number of contacts Nombre de contacts	Dimensiones para la entrada del cable Dimensions of cable entry Capacité de serrage du câble			
								máx.		min.	
9	1.240	31.5	1.200	30.5	.716	18.2	9	.256	6.5	.118	3
15	1.653	42.1	1.338	34.0	.716	18.2	15	.315	8	.138	3.5
25	2.185	55.5	1.732	44.0	.716	18.2	25	.472	12	.196	5

Dimensiones de la caperuza CTI
 CTI Hood dimensions
 Dimensions du capot CTI

Dimensiones en pulgadas y mm.
 Dimensions in inches and mm.
 Dimensions en pouces et mm.

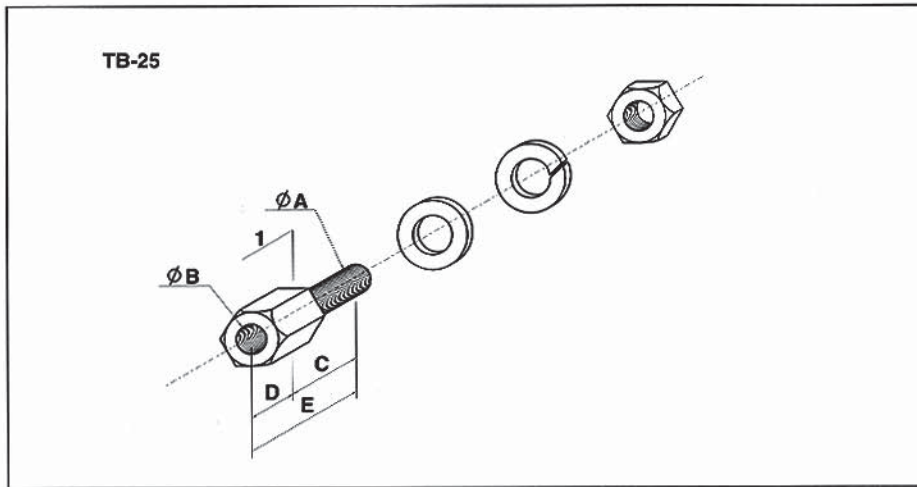

Designación Designation Designation	Dimensiones Dimensions Dimensions	
* TB-25		
Ø A	4-40 UNC	
Ø B	4-40 UNC	
C	.315	8
D	.196	5
E	.512	13

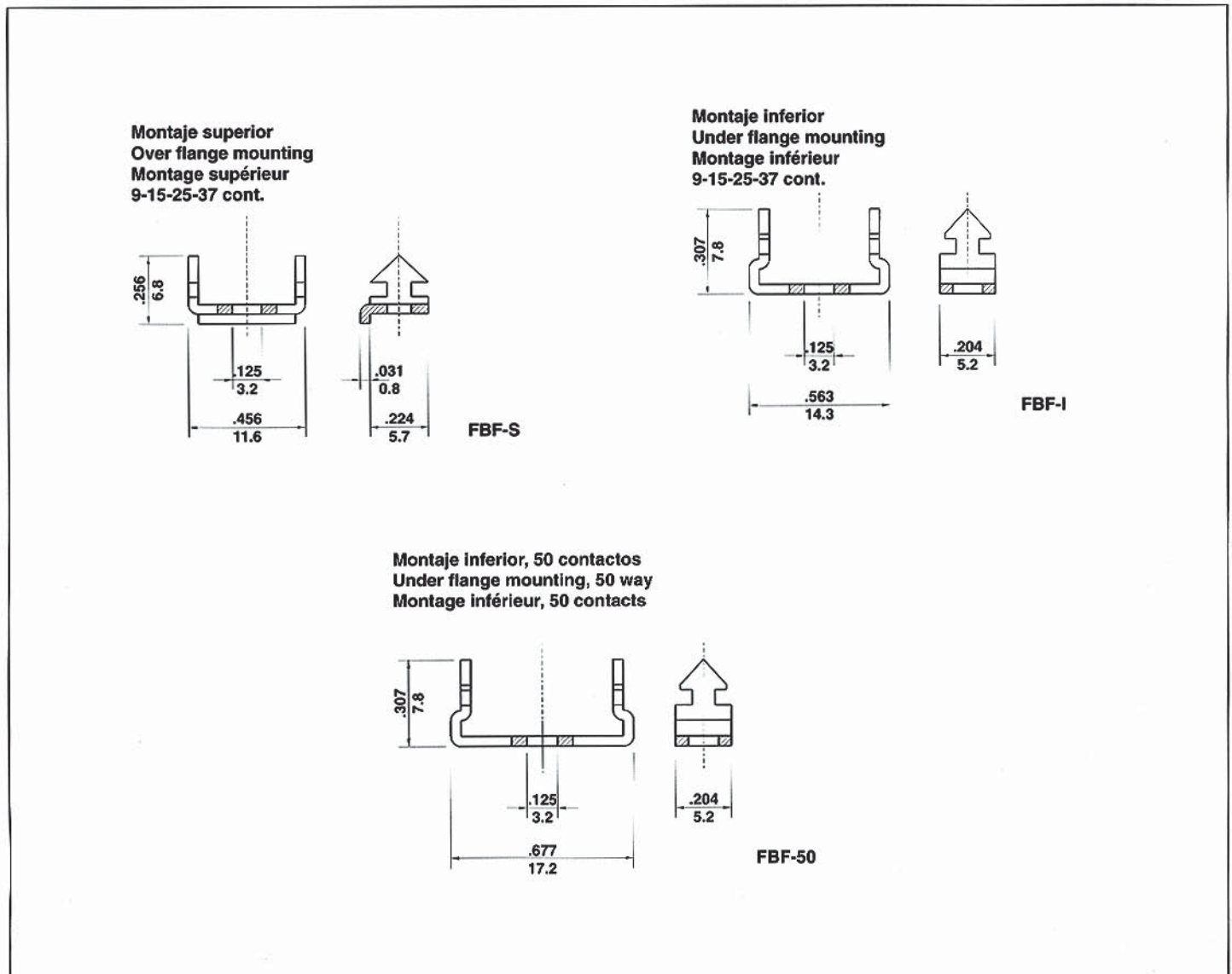

* Otras TB bajo demanda / Other TB on request / Autres TB sur demande

CAPERUZAS C - PCE
C - PCE HOODS
CAPOTS C - PCE

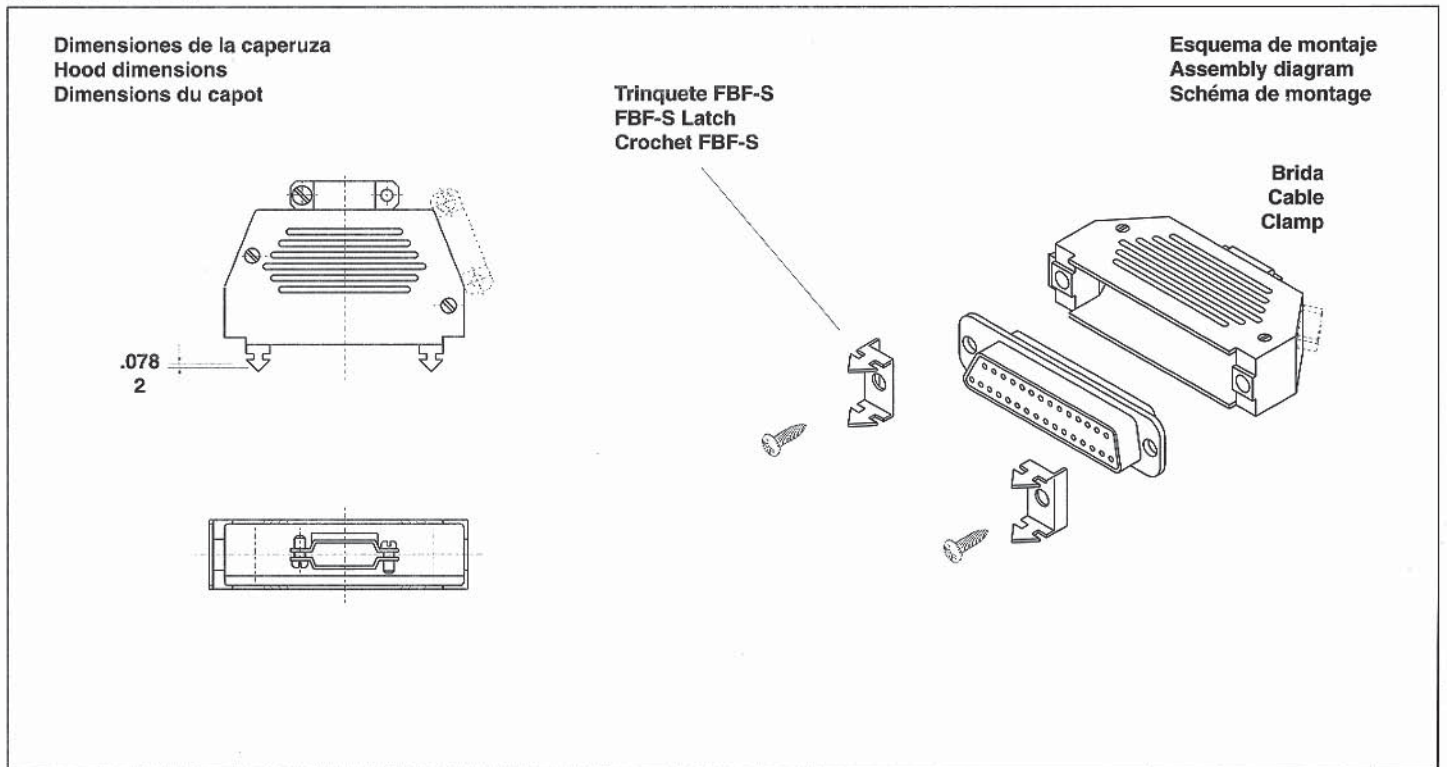

CAPERUZAS PCT
PCT HOODS
CAPOTS PCT

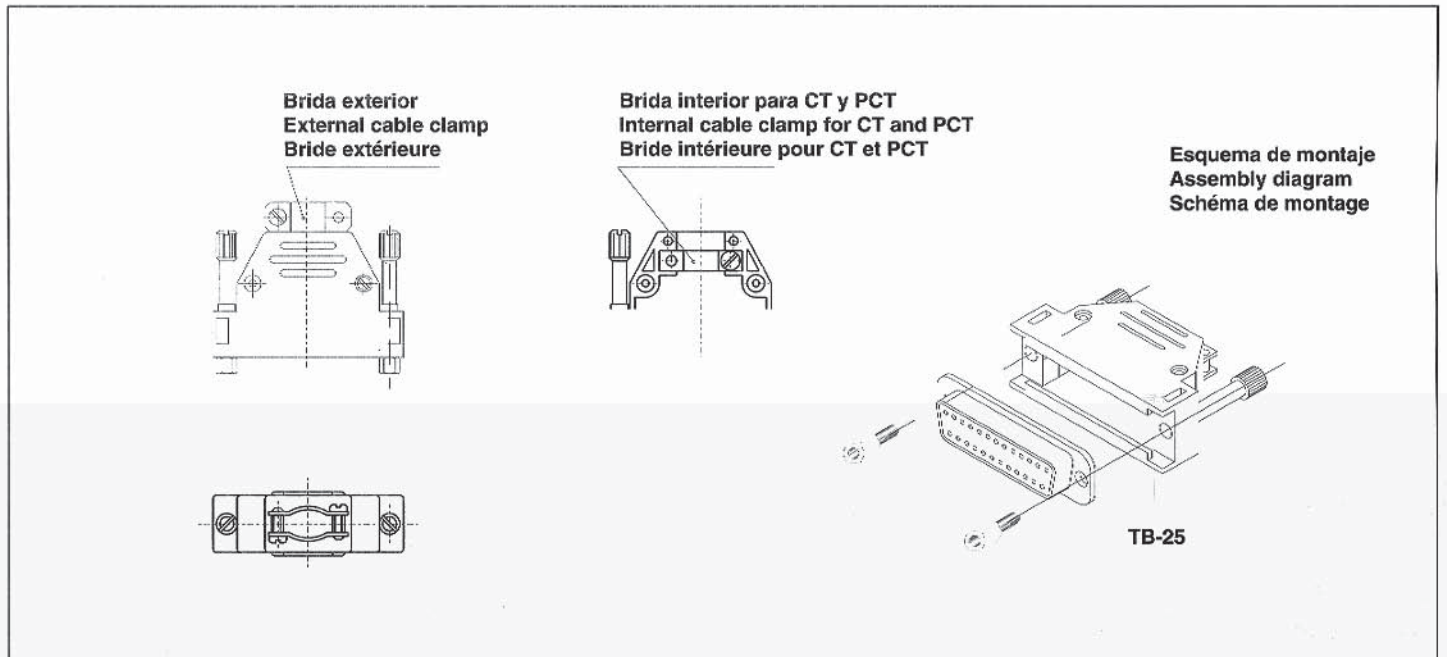

Caperuza CT28 y para cable plano

CT 28 Hood end hood for flat cable

Capot CT28 et capot pour câble plat

CAPERUZA CT 28 CT 28 HOOD CAPOT CT 28

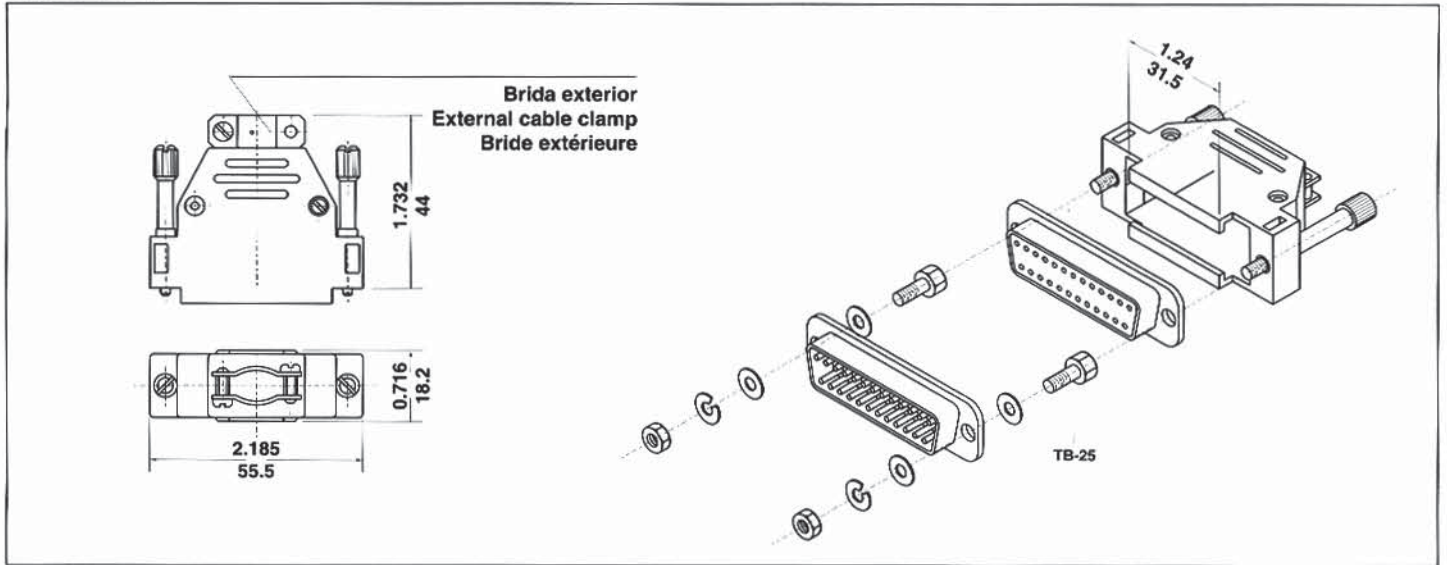

CAPERUZA PARA CABLE PLANO CP - CPE CP - CPE HOOD FOR FLAT CABLE CAPOT CP - CPE POUR CÂBLE PLAT

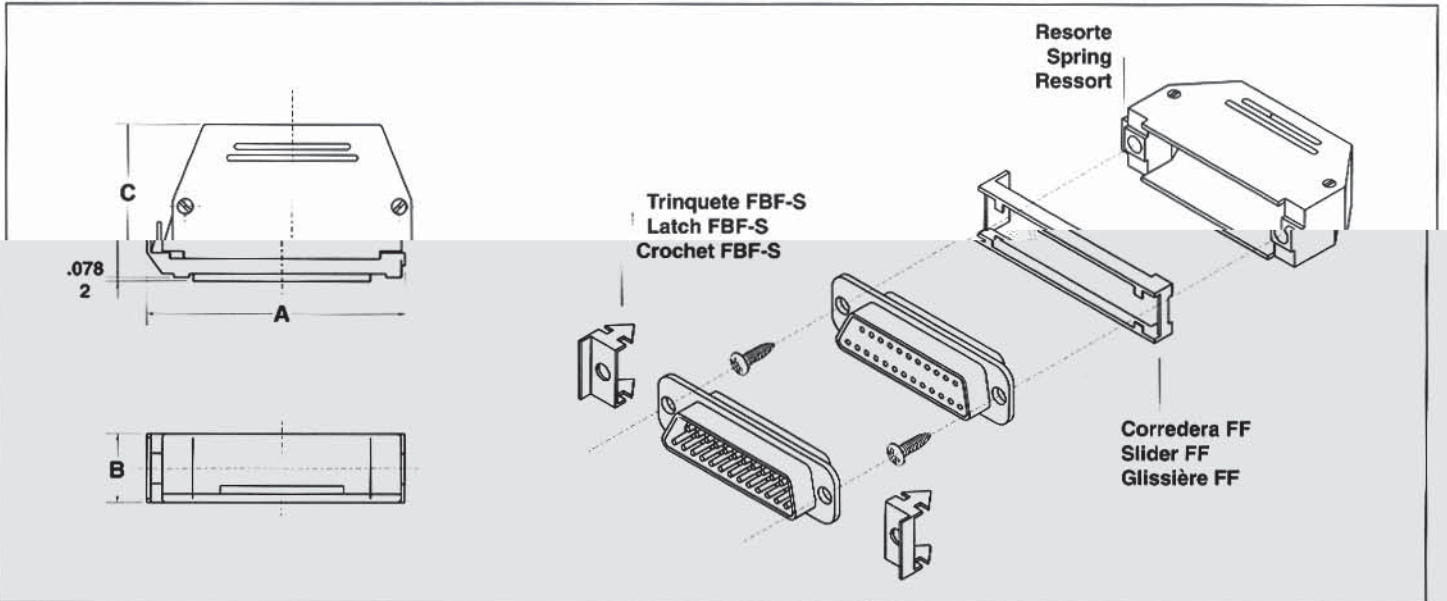

Número de contactos Number of contacts Nombre de contacts	Dimensiones-Dimensions-Dimensions					
	A		B		C	
25	2.362	60	.630	16	1.417	36

CAPERUZA CON BRIDA INTERIOR FLOTANTE CTF CTF HOOD WITH FLOATING INTERIOR CLAMP CAPOTS AVEC SERRE-CÂBLE INTÉRIEUR FLOTTANT CTF

Número de contactos Number of contacts Nombre de contacts	Dimensiones para la entrada del cable Dimensions of cable entry Capacité de serrage du câble			
	máx.		min.	
50	.393 x 6.30	10 x 16	.196 x .630	5 x 16

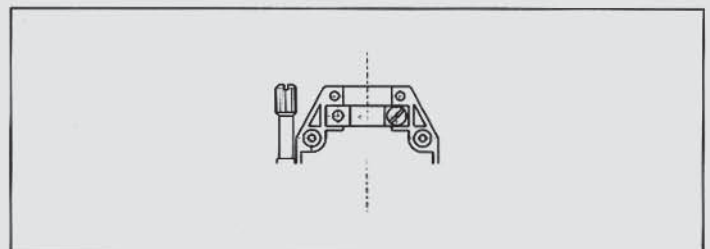

DESIGNACION COMERCIAL/ INFORMATION FOR ORDERING HOODS/ DESIGNATION COMMERCIALE

S D R

CT

25

M

Serie / Series / Série

(C, CE, PCE, CT, PCT)

(CTI) Sólo 9, 15, 25 contactos / Only for 9, 15, 25 contacts / Seulement pour 9, 15, 25 contacts

(CP, CPE, PCPE)

(CT28) Sólo para 25 contactos / Only for 25 contacts / Seulement pour 25 contacts

Número de contactos/ Number of contacts/ Nombre de contacts

(9, 15, 25, 37, 50) 4-40 UNC

(10, 16, 26, 38, 51) *M 2.5

Acabado de la caperuza/ Hood finish/ Finition du capot

(-) Plástico color negro, estándar

(M) Metalizado (niquelado)

(-) Standard black plastic

(M) Metallized (nickel plated)

(-) En plastique couleur noire, standard

(M) Métallisé (nickelé)

Nota: (-) No indicar

Note: (-) Omit

Note: (-) Ne rien indiquer

* Bajo demanda

* On request

* Sur demande



Conector doble entrada para C.I.

Stacked assemblies

Connecteur à double entrée à sortie coudée

Conector de alta calidad y rendimiento. Por su diseño, menor ocupación de espacio y reducción de los costos de instalación. Modelos de 9, 15, 25 y 37 contactos. Contactos machos y hembras, indistintamente en el mismo conjunto.

Otras características:
Gran precisión en contactos.
Carcasas bichromatadas o niqueladas.
Intercambiable con todos los conectores de la serie D.
Versión Dimple.

High quality performance. The design saves space and reduces assembly costs. Versions with 9, 15, 25 and 37 contacts. Male and female connectors can be mixed in the same assembly.

Other characteristics:
Precision machined contacts.
Shells: yellow chromated or nickel plated
Interchangeable with all D series connectors conforming to MIL-C-24308.
Dimple version.

Connecteur d'excellente qualité et de haut rendement. Par sa forme, réduit l'occupation d'espace et abaisse les coûts d'installation. Modèles: à 9, 15, 25, 37 contacts. Type des contacts: mâle/mâle femelle/femelle ou femelle/mâle.

Autres caractéristiques:
Grande précision des contacts.
Boîtiers bichromatés ou nickelés.
Compatibles avec tous les connecteurs série D.
Version Dimple.

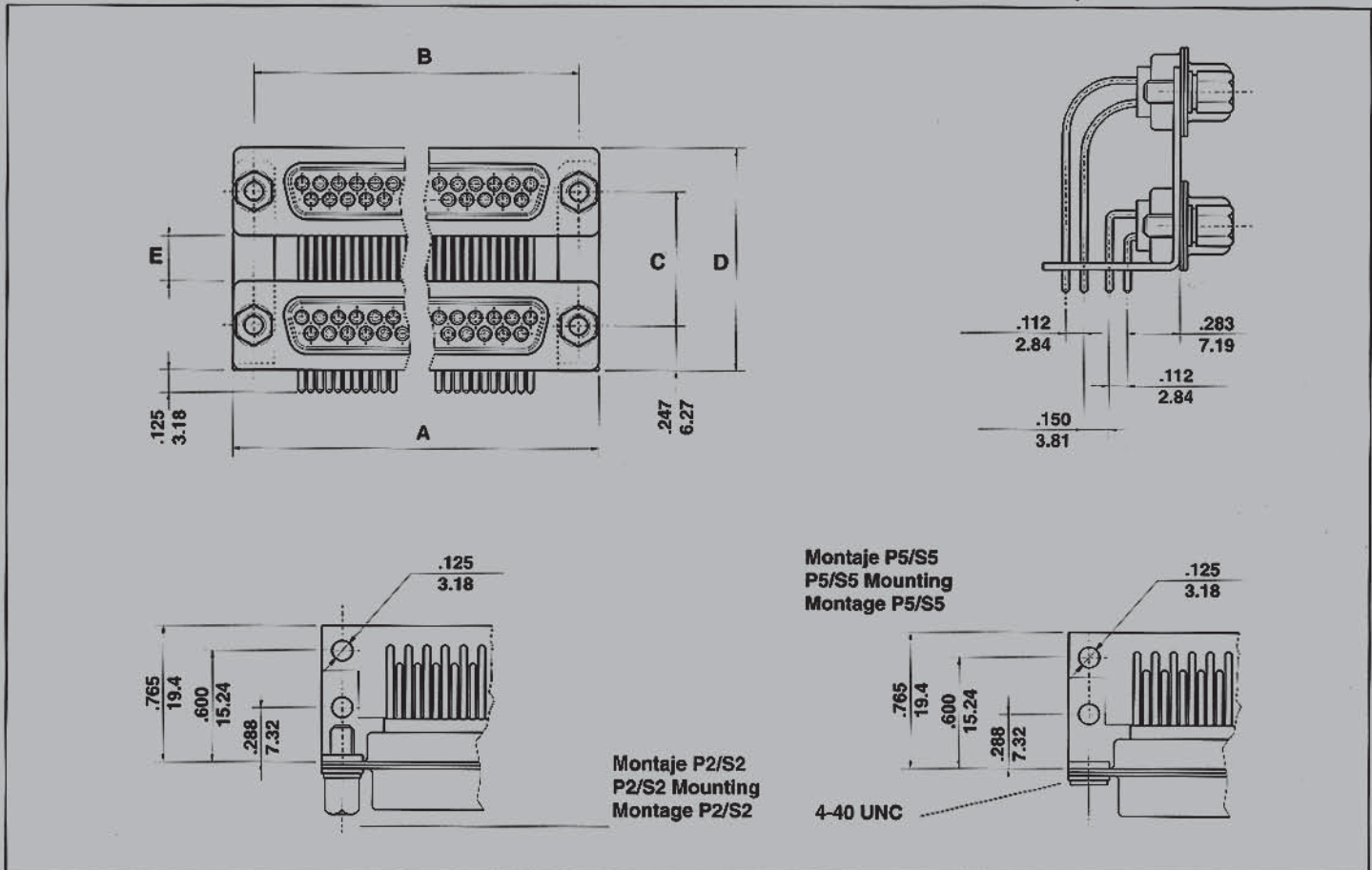

REF.	Tipo de conector Connector type Type de connecteur	Número de contactos Number of contacts Nombre de contacts	A	B	C	D	E
SD BN - 9	9	18	1.213 30.8	0.984 25	0.748 19	1.236 31.4	0.260 6.6
SD BN -15	15	30	1.542 39.15	1.311 33.3	0.748 19	1.236 31.4	0.260 6.6
SD BN - 25	25	50	2.083 52.9	1.850 47	0.748 19	1.236 31.4	0.260 6.6
SD BN - 37	37	74	2.732 69.4	2.500 63.5	0.748 19	1.236 31.4	0.260 6.6

Dimensiones en pulgadas y mm.
Dimensions in inches and mm.
Dimensions en pouces et mm.

Retículas de montaje en C.I.
Board drilling details
Perçage des cartes C.I.

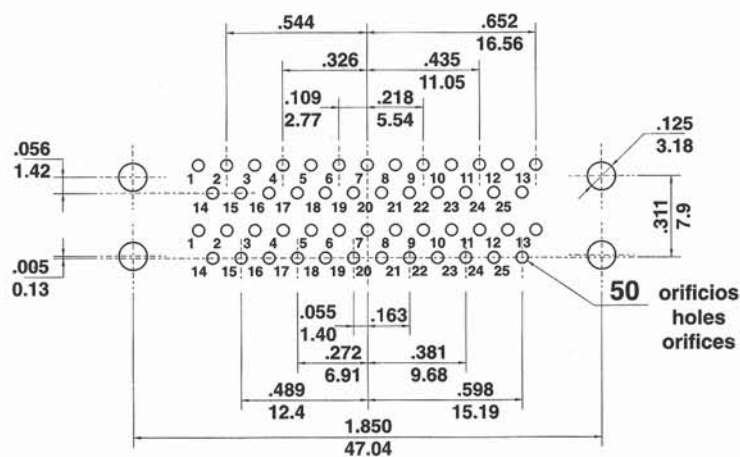
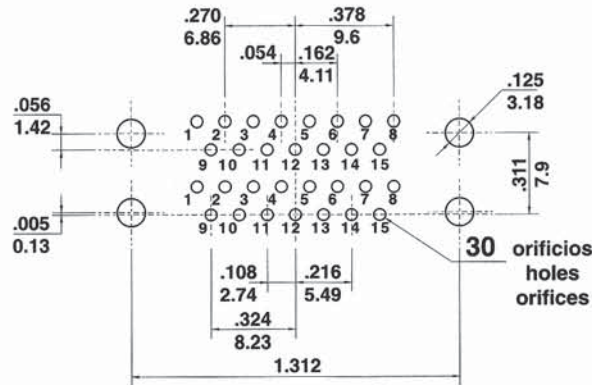
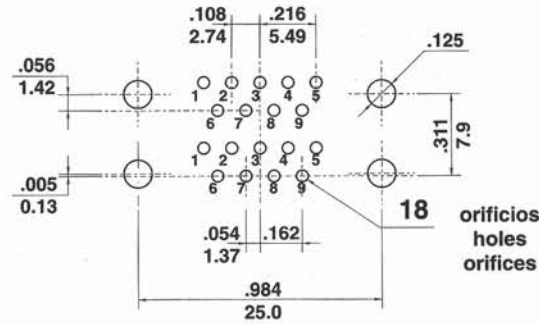

El montaje de los conectores se realiza con la cara frontal en el sentido de la flecha.
Mount connector with mating face positioned to follow direction of arrow.
Le montage des connecteurs s'effectue en positionnant la face d'accouplement dans le sens de la flèche.

Dimensiones en pulgadas y mm.
Dimensions in inches and mm.
Dimensions en pouces et mm.

Retículas de montaje en C.I.
Board drilling details
Perçage des cartes C.I.

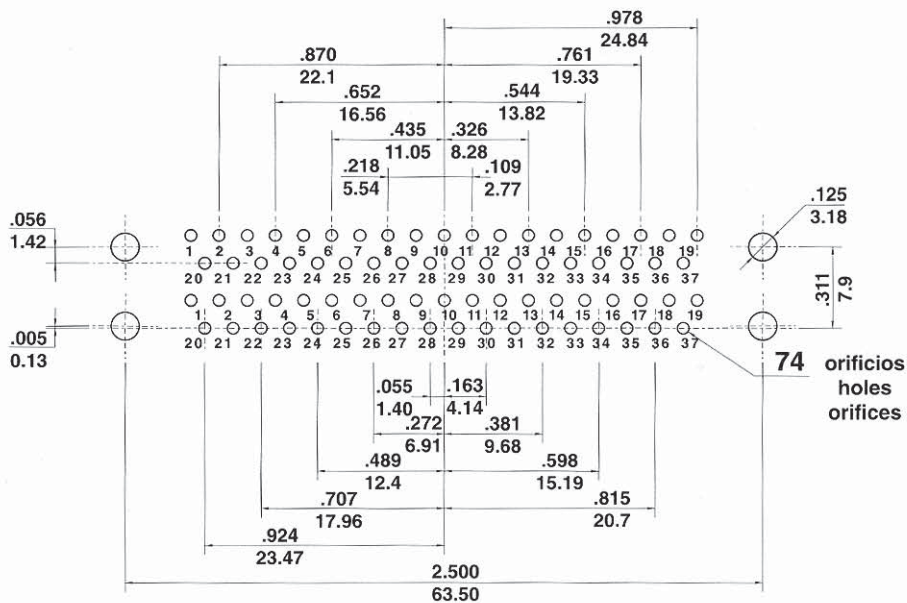

El montaje de los conectores se realiza con la cara frontal en el sentido de la flecha.

Mount connector with mating face positioned to follow direction of arrow.

Le montage des connecteurs s'effectue en positionnant la face d'accouplement dans le sens de la flèche.

Dimensiones en pulgadas y mm.

Dimensions in inches and mm.

Dimensions en pouces et mm.

DESIGNACION COMERCIAL / ORDERING CODE / DÉSIGNATION COMMERCIALE

SD BN

D

9

P

2

Serie/ Series/ Série

SDBN Serie D / SDBN Series D / SDBN Série D

Carcasa / Shell / Boitier

(-) - Estándar bicromatada / Standard Yellow chromated / Standard bichromaté
(D) - Dimple / Dimples / Dimple
(T) - Niquelada / Nickel plated / Nickelé

**Número de contactos del conector superior
Number of contacts of top connector
Nombre de contacts du connecteur supérieur**

9, 15, 25, 37

**Ref. contactos del conector superior
Contact designation top connector
Réf. contacts connecteur supérieur**

P - Macho / Male / Mâle
S - Hembra / Female / Femelle

**Accesorios de montaje conector superior
Mounting devices top connector
Accessoires de montage connecteur supérieur**

- (2) Fijación mediante torreta TB-25
Mounting with jackpost TB-25
Montage avec colonnette TB-25
- (5) Fijación mediante casquillo con rosca interior 4-40 UNC
Riveted with 4-40 UNC thread
Montage avec rivet trou taraudé 4-40 UNC

Otros montajes bajo demanda
Other mountings on request
Autres montages sur demande

Nota: (-) No indicar
Note: (-) Omit
Note: (-) Ne rien indiquer



DESIGNACION COMERCIAL / ORDERING CODE / DÉSIGNATION COMMERCIALE

SD BN D 9 P 2

9

S

M02

Número de contactos del conector inferior
Number of contacts of bottom connector
Nombre de contacts du connecteur inférieur

9, 15, 25, 37

Ref. contactos del conector inferior
Contact designation bottom connector
Réf. contacts connecteur inférieur

P - Macho / Male / Mâle
S - Hembra / Female / Femelle

Accesorios de montaje conector inferior
Mounting devices bottom connector
Accessoires de montage connecteur inférieur

(2) Fijación mediante torreta TB-25
Mounting with jackpost TB-25
Montage avec colonnette TB-25

(5) Fijación mediante casquillo con rosca interior 4-40 UNC
Riveted with 4-40 UNC thread
Montage avec rivet trou taraudé 4-40 UNC

Otros montajes bajo demanda
Other mountings on request
Autres montages sur demande

Nota: (-) No indicar
Note: (-) Omit
Note: (-) Ne rien indiquer



CONECTORES CIRCULARES

CIRCULAR CONNECTORS

CONNECTEURS CIRCULAIRES



CONECTORES RECTANGULARES (SM)

RECTANGULAR CONNECTORS (SM)

CONNECTEURS RECTANGULAIRES (SM)



TOMAS DE CORRIENTE PARA ALTA INTENSIDAD (A.I.)

HIGH POWER UNITS (A.I.)

PRISES POUR HAUTE INTENSITÉ (A. I.)



TOMAS DE CORRIENTE PARA GRÚAS DE PUERTO

POWER CONNECTOR SYSTEM FOR PORT CRANES

PRISES DE COURANT POUR GRUES PORTUAIRES



I.C.P. S.L.
(Factory)

Venezuela 84-94, Local 10
08019 BARCELONA
SPAIN

Tel.: +34-93 266 27 68
Fax: +34-93 266 23 89
E-mail: ventas@icpsl.com
<http://www.icpsl.com>



CEEP LTD.

Unit 7, Haslemere Ind. Estate,
Haslemere, Surrey GU27 1DW
U.K.

Tel.: +44-(0)1428 661515
Fax: +44-(0)1428 644147
E-mail: sales@ceep.co.uk
<http://www.ceep.co.uk>



DICONNEX

Parc d'Activités du Moulin Basset
12, Chemin du Moulin Basset, Bât.4 - 3^{ème}
93206 SAINT-DENIS

FRANCE
Tel.: +33-1-42.35.75.75
Fax: +33-1-42.35.97.77
E-mail: contact@diconnex.fr
<http://www.diconnex.fr>

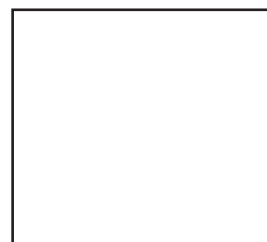

X-ON Electronics

Largest Supplier of Electrical and Electronic Components

Click to view similar products for [Ceep](#) manufacturer:

Other Similar products are found below :

[Ceep](#)