

# DS7 series soft start controllers, Frame 2 (16–32A)



## Introduction

Eaton's DS7 solid-state soft start controller is an electronic, self-contained panel- or enclosure-mounted motor soft-starting device. It provides three-phase induction motors with a smooth start, both mechanically and electrically. The DS7 line uses four silicon-controlled rectifiers (SCRs) that are connected in a full wave-power bridge on two phases. The voltage and current applied to the motor are controlled by varying the SCR conduction period. This, in turn, controls the torque developed by the motor. After the motor reaches speed, a bypass relay is energized to bypass the SCRs. The DS7 is designed to fulfill the industrial service requirements of applications such as chiller starters, pump panels, and machine tools. This device meets all relevant specifications set forth by UL® 508, IEC 60947-4-2, CE, C-Tick, and CSA®.

This leaflet covers basic installation and setup. No publication can take into account every possible situation. If you require further assistance with any aspect of this product or a particular application, contact Eaton.

## Inspection

### General

Upon receipt of the unit, verify that the catalog number and unit options stated on the shipping container match those stated on the order/purchase form.

Inspect the equipment upon delivery. Report any carton damage to the carrier prior to accepting the delivery. Have this information noted on the freight bill. Eaton is not responsible for damage incurred in shipping.

### Unpacking

Remove all packing material from the unit. Be sure to remove all packing material from the lug location.

Check the unit for any signs of shipping damage. If damage to the product is found after unpacking, report it to the freight company. Retain the packing materials for the carrier to review.

Verify that the unit's catalog number and options match those stated on the order/purchase form.

# EAT•N

Powering Business Worldwide

## Storage

It is recommended that the unit be stored in its original shipping box/crate until it is to be installed.

The unit should be stored in a location where:

- The ambient temperature is between  $-13^{\circ}$  to  $140^{\circ}\text{F}$  ( $-25^{\circ}$  to  $55^{\circ}\text{C}$ )
- The relative humidity is between 0% and 95%, noncondensing
- The environment is dry, clean, and noncorrosive
- The unit will not be subjected to high shock or vibration conditions

## Mounting instructions

The DS7 solid-state soft start controller is easy to mount. It does not require any special tools. To aid you with panel layout, refer to the dimension drawings shown in **Figure 1**. Drill and tap holes per mounting hole/slot locations as shown. To mount the unit, use all the hardware specified in **Table 1** of this leaflet. Tighten to the specified torque.

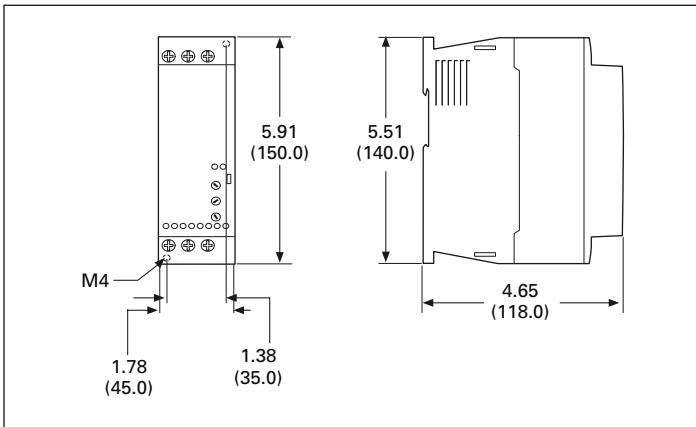

Figure 1. 16–32A models

### **⚠ DANGER—HIGH VOLTAGE**

**HAZARDOUS VOLTAGE CAN CAUSE ELECTRIC SHOCK AND BURNS. TO AVOID SHOCK HAZARD, DISCONNECT ALL POWER TO THE CONTROLLER, MOTOR, OR OTHER CONTROL DEVICES BEFORE ANY WORK IS PERFORMED ON THIS EQUIPMENT. FAILURE TO DO SO WILL RESULT IN PERSONAL INJURY, DEATH, OR SUBSTANTIAL PROPERTY DAMAGE.**

**DO NOT APPLY A DISCONNECT DEVICE ON THE OUTPUT OF THE DS7 SOFT START CONTROLLER UNLESS A MEANS TO TURN OFF THE DEVICE WHEN DISCONNECT SWITCH IS OPEN IS UTILIZED. OPENING THE DISCONNECT WHILE THE SOFT START CONTROLLER IS OPERATING MAY CAUSE A MALFUNCTION. CLOSING THE DISCONNECT SWITCH WHILE THE SOFT START CONTROLLER IS OPERATING WILL RESULT IN POTENTIAL EQUIPMENT DAMAGE AND PERSONNEL HAZARD.**

Table 1. Mounting hardware and torque specifications

Screw Size + Flat and Lock Washer	Quantity	Torque Requirements	Unit Weight Lbs (kg)
M4	4	10 lb-in (1.2 Nm)	0.9 (0.4)

Table 2. Environmental requirements

Description	Requirement
Operating temperature	$32^{\circ}$ to $104^{\circ}\text{F}$ ( $0^{\circ}$ to $40^{\circ}\text{C}$ ) up to $140^{\circ}\text{F}$ ( $60^{\circ}\text{C}$ ) with derating of 1% of rated current per Kelvin
Storage temperature	$13^{\circ}$ to $140^{\circ}\text{F}$ ( $-25^{\circ}$ to $60^{\circ}\text{C}$ )
Elevation	Up to 1000m; up to 2000m with derating of 1% rated current for each 100m
Humidity	Functional to 95% noncondensing
Operating orientation	Less than 30 degrees from horizontal
Minimum clearance—Upper and lower	2.165 in (55 mm) to a wall, 0.984 in (25 mm) to an upper and lower NZM1 (size 1), 1.378 in (35 mm) to an NZM2 (size 2), consult documentation of the breaker used (ionization emissions)
Minimum clearance—sides	0.0 in (0 mm)
Minimum clearance—face	0.198 in (5 mm)
Shock resistance	8g for 11 ms in any direction
Vibration resistance	2M2 EN 60721-3-2: 10g (3.5 mm amplitude, 9 to 200 Hz)
Environment	Suitable for installation in a pollution Degree 2 environment
Emissions	The device is suitable for use in industrial environments in accordance with EN 55011/22 Class A

## Power wiring

Using the wiring diagram in **Figure 2** and **Table 3** as guides, connect the line and motor wiring in accordance with appropriate local and national codes.

**Note:** To provide optimum motor protection, the line and motor power wiring should be tightly bundled and run perpendicular to the orientation of the DS7. Soft start controller to motor cable length is not to exceed 325 ft (100m).

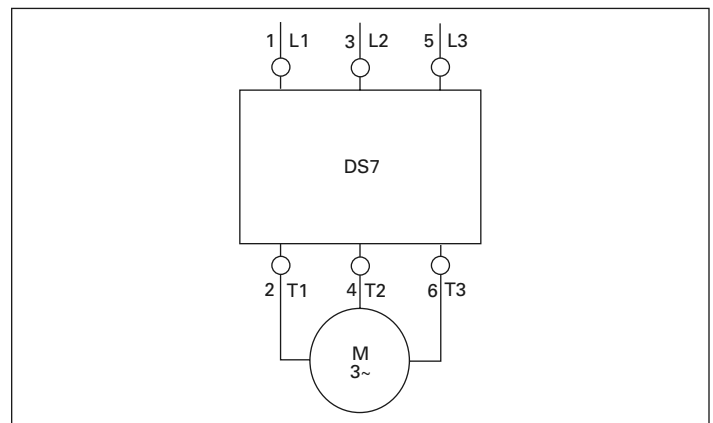

Figure 2. Power wiring diagram

Table 3. Power wire sizing and torque requirements

Wire Size	Torque	Wire Strip Length
18–6 AWG	26.55 lb-in	10 mm

### **⚠ DANGER**

**HAZARDOUS VOLTAGE. WILL CAUSE DEATH OR SERIOUS INJURY.**

**HAZARDOUS VOLTAGE IS PRESENT IN THE OFF/STOP STATUS OF THE SOFT START CONTROLLER WHEN THE LINE VOLTAGE IS ENERGIZED.**

**Product selection—horsepower ratings**

Please refer to Application Note AP03901006E for additional information on proper size selection.

**Table 4. 10 second ramp, one start per hour, 300% current limit at 40°C ①**

Rated Current (A)	Motor Power (hp)			Maximum Allowable Breaker Size	Maximum Allowable Fuse Size	Recommended XTOB Overload (Direct Connect) ②	Recommended XTOE Overload ②	MMP ②	Connection Kit to MMP	Catalog Number
	200V	230V	480V							
15.2	3	5	10	HFD3035	25A Class RK5	XTOB016CC1	XTOE020CCS	XTPR016BC1	XTPAXTPCC	DS7-340SX016NO-N ③ DS7-342SX016NO-N ④
22	5	7.5	15	HFD3060	40A Class RK5	XTOB024CC1	XTOE045CCS	XTPR025BC1	XTPAXTPCC	DS7-340SX024NO-N ③ DS7-342SX024NO-N ④
32	7.5	10	20	HFD3070	50A Class RK5	XTOB032CC1	XTOE045CCS	XTPR032BC1	XTPAXTPCC	DS7-340SX032NO-N ③ DS7-342SX032NO-N ④

**Table 5. 10 second ramp, one start per hour, 400% current limit at 40°C ①**

Rated Current (A)	Motor Power (hp)			Maximum Allowable Breaker Size	Maximum Allowable Fuse Size	Recommended XTOB Overload (Direct Connect) ②	Recommended XTOE Overload ②	MMP ②	Connection Kit to MMP	Catalog Number
	200V	230V	480V							
11	3	5	7.5	HFD3035	25A Class RK5	XTOB016CC1	XTOE020CCS	XTPR016BC1	XTPAXTPCC	DS7-340SX016NO-N ③ DS7-342SX016NO-N ④
17.5	5	5	10	HFD3060	40A Class RK5	XTOB016CC1	XTOE020CCS	XTPR016BC1	XTPAXTPCC	DS7-340SX024NO-N ③ DS7-342SX024NO-N ④
22	5	7.5	15	HFD3070	50A Class RK5	XTOB025CC1	XTOE045CCS	XTPR025BC1	XTPAXTPCC	DS7-340SX032NO-N ③ DS7-342SX032NO-N ④

**Product selection—kW ratings according to IEC 60947-4-2**

Please refer to Application Note AP03901006E for additional information on proper size selection.

**Table 6. 10 second ramp, one start per hour, 300% current limit at 40°C ①**

Rated Current (A)	Motor Power (kW)		Maximum Allowable Breaker Size	Maximum Allowable Fuse Size	Recommended XTOB Overload (Direct Connect) ②	Recommended XTOE Overload ②	MMP ②	Connection Kit to MMP	Catalog Number
	230V	400V							
16	4	7.5	HFD3035	25A Class RK5	XTOB016CC1	XTOE020CCS	XTPR016BC1	XTPAXTPCC	DS7-340SX016NO-N ③ DS7-342SX016NO-N ④
24	5.5	11	HFD3060	40A Class RK5	XTOB024CC1	XTOE045CCS	XTPR025BC1	XTPAXTPCC	DS7-340SX024NO-N ③ DS7-342SX024NO-N ④
32	7.5	15	HFD3070	50A Class RK5	XTOB032CC1	XTOE045CCS	XTPR032BC1	XTPAXTPCC	DS7-340SX032NO-N ③ DS7-342SX032NO-N ④

**Table 7. 10 second ramp, one start per hour, 400% current limit at 40°C ①**

Rated Current (A)	Motor Power (kW)		Maximum Allowable Breaker Size	Maximum Allowable Fuse Size	Recommended XTOB Overload (Direct Connect) ②	Recommended XTOE Overload ②	MMP ②	Connection Kit to MMP	Catalog Number
	230V	400V							
12	3	5.5	HFD3035	25A Class RK5	XTOB016CC1	XTOE020CCS	XTPR016BC1	XTPAXTPCC	DS7-340SX016NO-N ③ DS7-342SX016NO-N ④
16	4	7.5	HFD3060	40A Class RK5	XTOB016CC1	XTOE020CCS	XTPR016BC1	XTPAXTPCC	DS7-340SX024NO-N ③ DS7-342SX024NO-N ④
24	6.5	11	HFD3070	50A Class RK5	XTOB025CC1	XTOE045CCS	XTPR025BC1	XTPAXTPCC	DS7-340SX032NO-N ③ DS7-342SX032NO-N ④

**Notes**

① Actual motor FLAs vary. Verify these devices cover the motor specific FLA.

② Selections are based on motor FLA value at 480V.

③ 24 Vac/Vdc device.

④ 120/230 Vac device.

### Control wiring

Control wiring is connected to the DS7 soft start controller on the front of the unit. Use the wiring diagrams in **Figure 3**, **Figure 4**, and the sizing/torque information in **Table 10** as guides.

**Table 8. Control wiring sizing and torque requirements**

Wire Size	Torque
16 AWG	10.62 lb-in

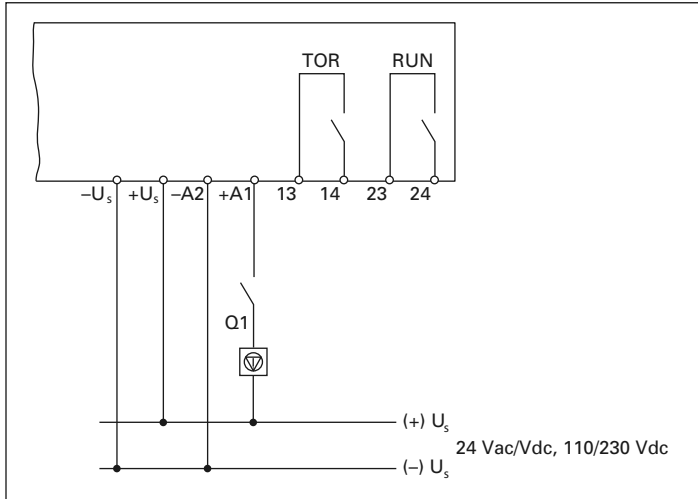

**Figure 3. Direct start control wiring without soft stop**

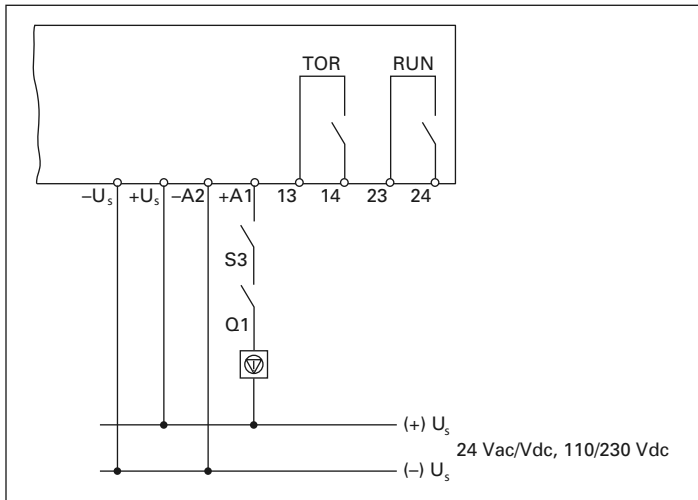

**Figure 4. Direct start control wiring with soft stop**

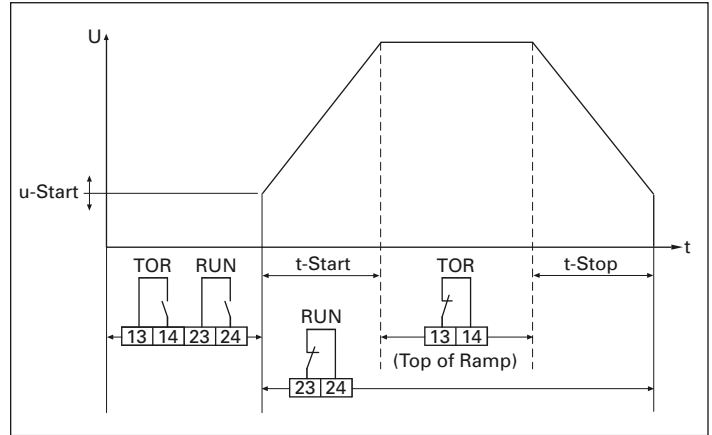

**Figure 5. Start and stop ramp functions**

**Table 9. Terminal designations**

Terminal	Description
-U <sub>s</sub>	Control ground or circuit common
+U <sub>s</sub>	Power of AC load
-A2	Common with -U <sub>s</sub>
+A1	Run command
13	Top of ramp contact—NO
14	Top of ramp contact—NO
23	Run contact—NO
24	Run contact—NO

**Table 10. DS7 terminal control block wiring**

Name	Block Designation	Input	Connections
Circuit common	-U <sub>s</sub>	Common	Control ground or circuit common
Power	+U <sub>s</sub>	24 Vac/Vdc/120–230 Vac maintained	Plus DC power or AC load
	-A2	Control power common	Common with -U <sub>s</sub>
	+A1	24 Vac/Vdc/120–230 Vac maintained	Run command
Relay	13, 14	NO contact rated at 250 Vac, 3A resistive, 1A inductive	Top of ramp signal—in bypass
Relay	23, 24	NO contact rated at 250 Vac, 3A resistive, 1A inductive	Run signal

### Control power requirements

The AC control power for your DS7 soft start controller must meet or exceed the following requirements:

- Minimum supply current:
  - 20 mA
  - 30 mA (with optional fan)
  - 100 mA (with optional fan, in bypass)
- Peak current requirement = 250 mA for 50 ms

## Operations

- 24 Vac/Vdc, 110/230 Vac control voltage is applied to terminal U<sub>s</sub>
- Line voltage is applied to the starter by closing the mains contactor
- The soft start controller issues a RUN command by applying 24 Vac/Vdc, 110/230 Vac to terminal +A1.
- Contacts 13/14 will close when the end of the ramp time is reached (TOR)
- Contacts 23/24 will close and remain closed for the duration of the RUN command, including a STOP ramp if enabled

**Note:** Bypass relays close at the end of ramp time + ~0.18 seconds. It is important to correctly set the ramp time, so the bypass relays will close within 5 seconds after the motor has achieved rated RPM.

- To remove the RUN command, remove control voltage from terminal +A1
- If ramp STOP time is set to a value greater than 0 seconds, a RAMP STOP will be performed

## Adjusting the soft start controller parameters

There are three adjustments to the DS7 soft start controller:

- t-Start = ramp time
- u-Start = initial voltage (torque)
- t-Stop = stop ramp time

**Table 11. DS7 parameters**

Application	t-Start	t-Stop	u-Start	Breakaway Torque	Remarks
Crusher, empty at start	20s	—	56%	75%	Possible high inertia
Conveyor, horizontal, loaded	25s	30s	76%	150%	—
Conveyor, horizontal, unloaded	25s	30s	48%	50%	—
Chiller	5s	—	37%	25%	—
Piston compressor, unloaded	10s	—	64%	100%	—
Circular saw	20s	—	48%	50%	Possible high inertia
Ball mill	20s	—	48%	50%	Eccentric load
Mixer, liquids	10s	—	37%	40%	—
Mixer, dry materials	15s	—	56%	75%	—
Pump, piston	25s	30s	82%	175%	Possible high starting torque
Pump, centrifugal	10s	30s	37%	25%	—
Escalator	10s	—	48%	50%	—
Rotary compressor, unloaded	20s	—	42%	35%	—
Agitator	15s	—	42%	35%	—
Feed screw	20s	—	82%	175%	Possible high starting torque
Press, flywheel	25s	—	76%	150%	Possible high starting torque
Drier, rotating	20s	—	64%	100%	—
Blower, axial fan, flaps open	30s	—	37%	25%	—
Blower, centrifugal fan, valve open	30s	—	35%	20%	—

### LED operation and troubleshooting

The operation, warning, and fault status of the controller may be determined by observing the pattern of LED illuminations. Only one condition may exist at any one time, with fault indications taking priority over others.

As conditions change, LED status will also change.

For example, during the initialization stage, the RED and GREEN LED's will flash alternately. When initialization is complete and the Enable signal is present, the GREEN LED will then flash one time per second and the RED LED will be off.

**Table 12. LED operations/warning indications**

Operation	← 1 Second →
Initialization	Green and Red LEDs flash alternately in a 1-second cycle.
Off	Both LEDs are off.
Supply voltage connection without enable	Green LED flashes once per second.
Supply voltage connection with enable	Green LED flashes once per second.
In ramp	Green LED flashes once per second.
TOR	Green LED is illuminated continuously.
<b>Warnings</b>	
Overtemperature for next start	Green LED flashes once per second.
Start without enable	Green LED flashes once per second.
Potentiometer not effective, network operation	Green LED flashes once per second.

In the event of a motor stop due to a trip condition by the soft start controller, the FAULT status LED will be illuminated (flashing). In this case, one or more conditions found in **Table 13** may have occurred.

**Tables 14, 15** and **16** may be used for evaluation or troubleshooting and contain additional information on operations and operating conditions.

**Table 13. LED fault indications**

Faults	← 1 Second →
Overtemperature, thyristor (I2t)	Green LED flashes once per second.
Overtemperature electronic	Green LED flashes once per second.
Over/under temperature heat sink	Green LED flashes once per second.
Thyristor is defective	Red LED is illuminated continuously.
Phase failure	Red LED is illuminated continuously.
Bypass is defective	Green LED flashes once per second.
Supply voltage faulty	Green LED flashes once per second.

**Table 14. Normal operation indications**

Status	LED	Condition	Action
Off	GREEN—Off RED—Off	Control voltage is not applied to terminals +U <sub>s</sub> and -A2.	No action required.
<b>Note:</b> Possible device failure if power is applied to these terminals and no LED's are illuminated.			
Initialization	GREEN—4x/s, pulse 1/8s RED—4x/s, pulse 1/8s alternating	Control power is applied to terminals +U <sub>s</sub> and -A2.	If the unit fails to properly initialize, verify that the notes LED indications are correct. If the LED indications are not correct, the unit requires service.
<b>Note:</b> When control power is applied to terminals +U <sub>s</sub> and -A2, the unit enters a short initialization period. If the initialization sequence fails, remove and reapply power.			
Supply voltage connection without enable	GREEN—1x/s, pulse 1/8s RED—1x/s, pulse 1/8s simultaneous	No control power signal at terminal EN.	Apply control power enable signal to terminal EN to allow RUN command
<b>Note:</b> Enable signal may be tied to RUN command signal.			
Supply voltage connection with enable	GREEN—1x/s, pulse 1/8s RED—Off	Unit ready for RUN command.	Apply RUN command to terminal +A1 to perform start.
<b>Note:</b> After successful initialization, the soft start controller is ready to perform START and RUN functions.			
In ramp	GREEN—1x/s, pulse 1/2s RED—Off	Unit is in START ramp. Unit is in STOP ramp.	START ramp and STOP ramp (if selected) operation is indicated.
<b>Note:</b> Set ramp times as short as practical. Ramp times should be adjusted to expire approximately 2 seconds after the motor has achieved synchronous RPM. Motor rotation (START) should occur within 2 seconds of RUN command. STOP ramp cannot shorten coast-to-stop time (no braking function). Motor acceleration/deceleration times are load dependent.			
TOR (Top of Ramp)	GREEN—Continuous RED—Off	Start ramp complete bypass contacts closed.	Unit is in normal operation.
<b>Note:</b> After a successful START ramp, the bypass relays close and the soft start controller is in a RUN condition. TOR will remain illuminated until RUN command is removed for coast stop or STOP ramp. Auxiliary relay contacts will change state at the same time as the TOR LED.			

**Table 15. Warning indications**

Status	LED	Condition	Action
Start without enable	GREEN—1x/s, pulse 1/2s RED—1x/s, pulse 1/2s simultaneous	RUN command is issued without a signal at the Enable terminal.	Apply Enable signal at terminal EN.
<b>Note:</b> Enable signal may be jumpered to RUN command signal.			
Overtemperature for next start	GREEN—1x/s, pulse 1/2s RED—1x/s, pulse 1/2s alternating	Thermal memory too high to attempt a start.	Delay RUN command. Reduce number of starts per hour. Increase frame size of soft start controller
<b>Note:</b> Thermal memory if the soft start controller calculates that the SCRs will be subject to overtemperature conditions during another start attempt. Thermal memory calculation is based on previous run conditions, not current potentiometer settings.			
Potentiometer not effective, network operation	GREEN 1x/s, pulse 1/2s + 1x/s, pulse 1/8s RED—Off	RUN parameter potentiometers cannot be adjusted.	The soft start controller is connected to a control network.
<b>Note:</b> The values of the potentiometers on the face of the controller are not recognized when the soft start controller is connected to a network.			

**Table 16. Fault indications**

Status	LED	Condition	Action
Overtemperature, SCR (I2t)	GREEN – 2x/s, pulse 1/8s RED—1x/s, pulse 1/2s simultaneous	Operating temperature of an SCR has been exceeded.	Allow controller to cool. Reduce operating load.
<b>Note:</b> Provide additional cooling to the enclosure if this fault is consistent with normal operation. Also consider increasing to a larger size soft start controller with a higher current rating.			
Overtemperature, electronic	GREEN—Continuous RED—1x/s, pulse 1/2s	Temperature of the printed circuit board has been exceeded.	Reduce operating temperature of the controller. Install cooling fans.
<b>Note:</b> Additional cooling may be provided with optional fans to reduce temperature inside the enclosure. If not mounted inside an enclosure, move the controller to an optimum location to reduce operating temperatures.			
Over/under temperature, heat sink	GREEN—Continuous RED—Continuous	Temperature of the SCR heat sink is not within operating specifications.	Reduce operating temperature. Increase operating temperature.
<b>Note:</b> Indication is the same for either high or low temperature. Note operating temperature of the environment. An infrared temperature device may be used on the face of the soft start controller to determine if the fault condition is either high or low temperature.			
Thyristor defective	GREEN—Off RED—Continuous	SCR is shorted. SCR is open.	Inspect controller for shorted SCR. Inspect controller for open SCR.
<b>Note:</b> In troubleshooting this condition, please note that one phase is a pass through connection and will indicate very low resistance when measured with test equipment. A shorted SCR will also indicate a very low resistance. Prior to replacing the soft start controller, verify that the respective bypass relay is not stuck or welded in the closed position. Normal; thyristor resistance is greater than 10k ohms, measured from line to load with all external devices disconnected from the controller.			
Phase failure	GREEN—Off RED—1x/s, pulse 1/2s	One or more of the line phases is missing.	Restore missing phases. Close isolation contactors if installed.
<b>Note:</b> Phase failure is not detected on the pass thru phase. Verify that phase failure is not transient.			
Bypass defective	GREEN—1x/s, pulse 1/2s RED—Off	Bypass relay closed prior to RUN command after initialization is complete. Bypass relay fails to close at the end of ramp time.	Inspect phases for evidence of closed bypass relay. Inspect phases for evidence of failed relay (voltage drop).
<b>Note:</b> Verify that the relay operates properly when TOR is achieved. Verify that the relay contacts are open when the controller has completed the initialization period.			
Supply voltage faulty	GREEN—4x/s, pulse 1/8s RED—1x/s, pulse 1/2s simultaneous	Control power voltage is not within operating specifications (high or low).	Verify correct voltage. Correct excessive voltage drop condition. Verify the CPT is sized correctly and output voltage is correct.
<b>Note:</b> Inspect supply voltage for proper level and stability. Verify that CPT is of sufficient capacity and that it is operating properly.			

## Service

For additional information on this product, please call Eaton's Technical Resource Center at (877) 386-2273 or visit our Web site at [www.eaton.com](http://www.eaton.com).

Service and repair is available from Eaton or several factory authorized regional service centers. Please contact Eaton's Product Integrity Center at (800) 345-0434 for the location nearest to you.

For field service or start-up assistance 24 hours a day, 7 days a week, please call (800) 498-2678.

**Eaton Corporation**  
Electrical Sector  
1111 Superior Ave.  
Cleveland, OH 44114  
United States  
877-ETN-CARE (877-386-2273)  
[Eaton.com](http://Eaton.com)

© 2011 Eaton Corporation  
All Rights Reserved  
Printed in USA  
Publication No. IL03901004E / Z10782  
February 2011



**PowerChain  
Management®**

PowerChain Management is a registered trademark of Eaton Corporation.

All other trademarks are property of their respective owners.



## X-ON Electronics

Largest Supplier of Electrical and Electronic Components

*Click to view similar products for [Motor Drives](#) category:*

*Click to view products by [Eaton](#) manufacturer:*

Other Similar products are found below :

[GMA02](#) [R7DBP02L](#) [R88DKN10HML2](#) [R88DKN20FECT](#) [R88DKN30FECT](#) [R88DKT04L](#) [R88DKT75F](#) [ST10-Plus](#) [GMA11](#) [GMA20](#)  
[R88DKN02LECT](#) [R88DKN30FML2](#) [R88DKN75FECT](#) [R88DUA03LAAC100V30W](#) [R88DUA12HA](#) [R88DUP03LAAC100V30W](#) [STR2](#)  
[VFD002EL11A](#) [SR24](#) [R88D-GT04H](#) [R88D-GN04H-ML2](#) [R88D-KT01H](#) [R7D-BP01H](#) [R88D-KN04L-ECT](#) [26231941](#) [26231720](#) [70354063](#)  
[79294435](#) [27358015](#) [26231703](#) [15275008](#) [ST5-Q-EN](#) [STAC6-QE](#) [R88D-GP08H](#) [GNCF8-11](#) [KLC35BE](#) [ST10-IP-EE](#) [ST10-Q-RN](#)  
[26231801](#) [26231909](#) [1302263161](#) [103H89223-6341](#) [UDS1UR6M50CANCZ183](#) [103H5208-5240](#) [103H5210-5240](#) [103H7126-0740](#)  
[103H8221-6240](#) [103H5205-5240](#) [103H7126-1740](#) [103H7126-5740](#)