

### 4 PIN DIP PHOTODARLINGTON PHOTOCOUPLER EL815 Series

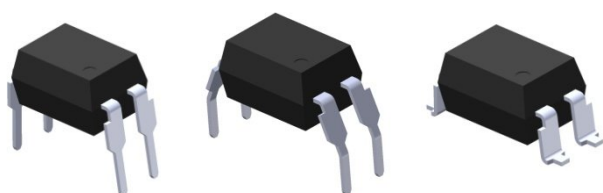

Schematic

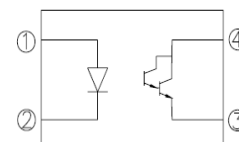

Pin Configuration

1. Anode
2. Cathode
3. Emitter
4. Collector

#### Features:

- Current transfer ratio (CTR: 600~7500% at  $I_F = 1\text{mA}$ ,  $V_{CE} = 2\text{V}$ )
- High isolation voltage between input and output (Viso=5000 V rms )
- Creepage distance >7.62 mm
- Operating temperature up to +110°C
- Compact small outline package
- Pb free and RoHS compliant.
- UL approved (No. E214129)
- VDE approved (No. 132249)
- CSA approved
- SEMKO approved
- NEMKO approved
- DEMKO approved
- FIMKO approved
- CQC approved

#### Description

The EL815 series of devices each consist of an infrared emitting diodes, optically coupled to a photo Darlington detector.

They are packaged in a 4-pin DIP package and available in wide-lead spacing and SMD option.

#### Applications

- Telephone set, telephone exchangers
- Sequence controllers
- System appliances, measuring instruments
- Signal transmission between circuits of different potentials and impedances

**Absolute Maximum Ratings (Ta=25 )**

	Parameter	Symbol	Rating	Unit
Input	Forward current	$I_F$	60	mA
	Peak forward current (1us, pulse)	$I_{FP}$	1	A
	Reverse voltage	$V_R$	6	V
	Power dissipation	$P_D$	100	mW
	No derating required up to Ta = 100°C			
Output	Power dissipation	$P_C$	150	mW
	Derating factor (above Ta = 80°C)		5.8	mW/°C
	Collector current	$I_C$	80	mA
	Collector-Emitter voltage	$V_{CEO}$	35	V
	Emitter-Collector voltage	$V_{ECO}$	7	V
Total power dissipation		$P_{TOT}$	200	mW
Isolation voltage *1		$V_{ISO}$	5000	V rms
Operating temperature		$T_{OPR}$	-55 ~ +110	°C
Storage temperature		$T_{STG}$	-55 ~ +125	°C
Soldering Temperature*2		$T_{SOL}$	260	°C

Notes:

\*1 AC for 1 minute, R.H.= 40 ~ 60% R.H. In this test, pins 1 & 2 are shorted together, and pins 3 & 4 are shorted together.

\*2 For 10 seconds

**Electro-Optical Characteristics (Ta=25 unless specified otherwise)**

**Input**

Parameter	Symbol	Min.	Typ.*	Max.	Unit	Condition
Forward Voltage	$V_F$	-	1.2	1.4	V	$I_F = 20\text{mA}$
Reverse Current	$I_R$	-	-	10	$\mu\text{A}$	$V_R = 4\text{V}$
Input capacitance	$C_{in}$	-	30	250	pF	$V = 0, f = 1\text{kHz}$

**Output**

Parameter	Symbol	Min.	Typ.*	Max.	Unit	Condition
Collector-Emitter dark current	$I_{CEO}$	-	-	1	$\mu\text{A}$	$V_{CE} = 10\text{V}, I_F = 0\text{mA}$
Collector-Emitter breakdown voltage	$BV_{CEO}$	35	-	-	V	$I_C = 0.1\text{mA}$
Emitter-Collector breakdown voltage	$BV_{ECO}$	7	-	-	V	$I_E = 0.1\text{mA}$

**Transfer Characteristics**

Parameter	Symbol	Min.	Typ.*	Max.	Unit	Condition
Current Transfer ratio	CTR	600	-	7500	%	$I_F = 1\text{mA}, V_{CE} = 2\text{V}$
Collector-Emitter saturation voltage	$V_{CE(sat)}$	-	0.8	1.0	V	$I_F = 20\text{mA}, I_C = 5\text{mA}$
Isolation resistance	$R_{IO}$	$5 \times 10^{10}$	-	-	$\Omega$	$V_{IO} = 500\text{Vdc}, 40\text{--}60\% \text{ R.H.}$
Floating capacitance	$C_{IO}$	-	0.6	1.0	pF	$V_{IO} = 0, f = 1\text{MHz}$
Cut-off frequency	$f_c$	-	6	-	kHz	$V_{CE} = 5\text{V}, I_C = 2\text{mA}, R_L = 100\Omega, -3\text{dB}$
Rise time	$t_r$	-	60	300	$\mu\text{s}$	$V_{CE} = 2\text{V}, I_C = 10\text{mA}, R_L = 100\Omega$
Fall time	$t_f$	-	53	250	$\mu\text{s}$	$R_L = 100\Omega$

\* Typical values at  $T_a = 25^\circ\text{C}$

Typical Electro-Optical Characteristics Curves

Figure 1. Forward Current vs Forward Voltage

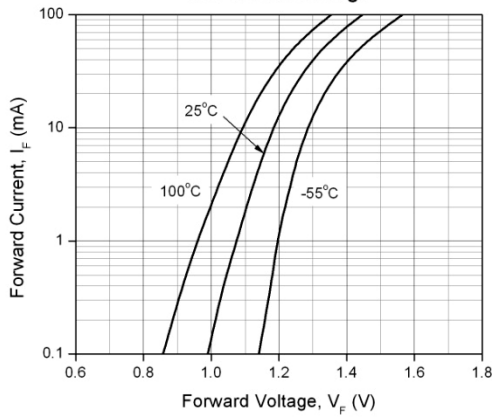

Figure 2. Current Transfer Ratio vs. Ambient Temperature

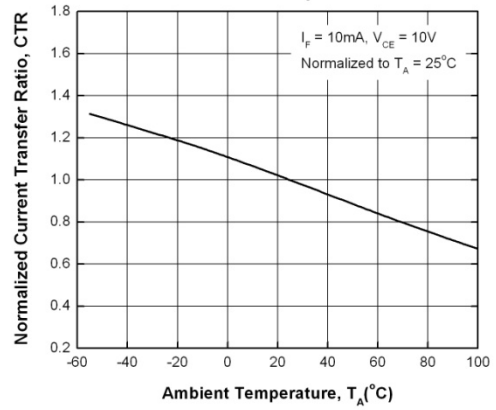

Figure 3. Normalized Current Transfer Ratio vs Forward Current

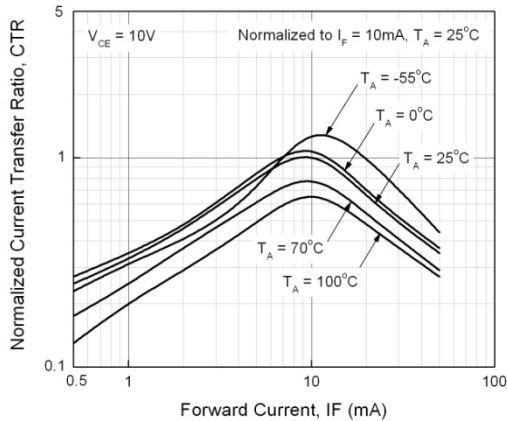

Figure 4. Collector Dark Current vs Ambient Temperature

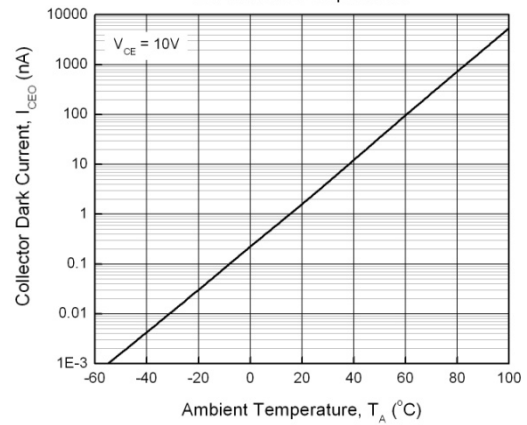

Figure 5. Turn-on Time vs Forward Current

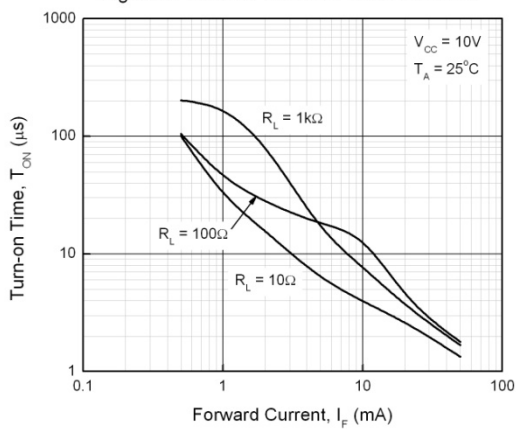
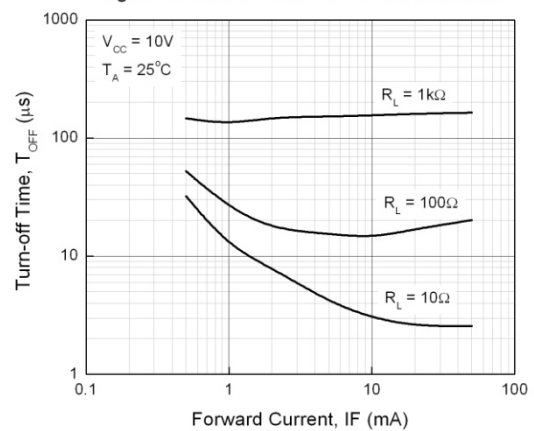

Figure 6. Turn-off Time vs Forward Current



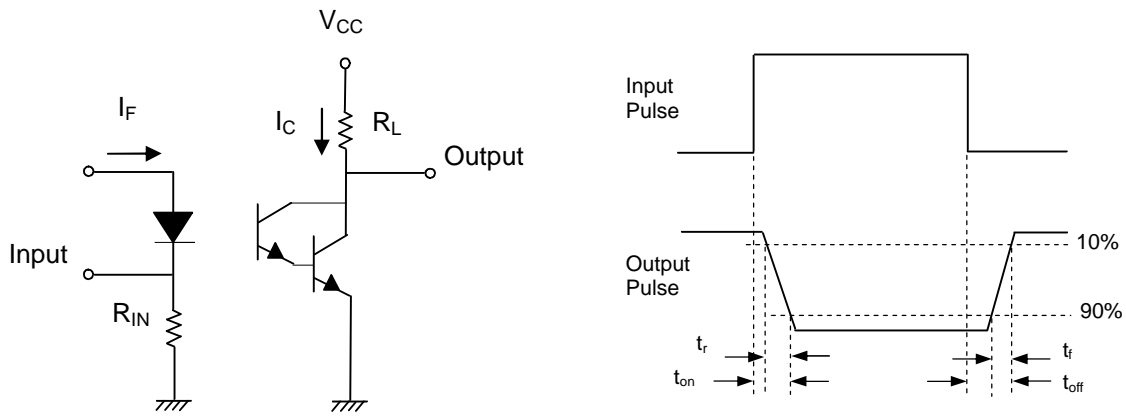

Figure 7. Switching Time Test Circuit & Waveforms

EVERLIGHT

**Order Information**

**Part Number**

**EL815X(Z)-V**

**Note**

- X = Lead form option (S, S1, M or none)
- Z = Tape and reel option (TA, TB ,TU, TD or none).
- V = VDE safety (optional).

Option	Description	Packing quantity
None	Standard DIP-4	100 units per tube
M	Wide lead bend (0.4 inch spacing)	100 units per tube
S (TA)	Surface mount lead form + TA tape & reel option	1000 units per reel
S (TB)	Surface mount lead form + TB tape & reel option	1000 units per reel
S1 (TA)	Surface mount lead form (low profile) + TA tape & reel option	1000 units per reel
S1 (TB)	Surface mount lead form (low profile) + TB tape & reel option	1000 units per reel
S (TU)	Surface mount lead form + TU tape & reel option	1500 units per reel
S (TD)	Surface mount lead form + TD tape & reel option	1500 units per reel
S1 (TU)	Surface mount lead form (low profile) + TU tape & reel option	1500 units per reel
S1 (TD)	Surface mount lead form (low profile) + TD tape & reel option	1500 units per reel

Package Dimension (Dimensions in mm)

Standard DIP Type

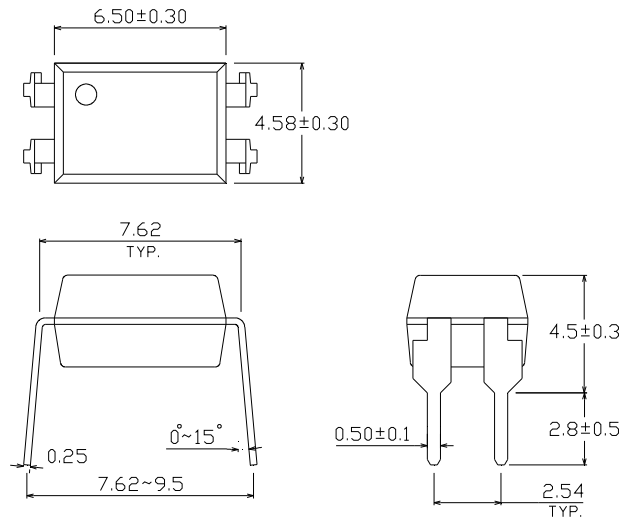

Option M Type

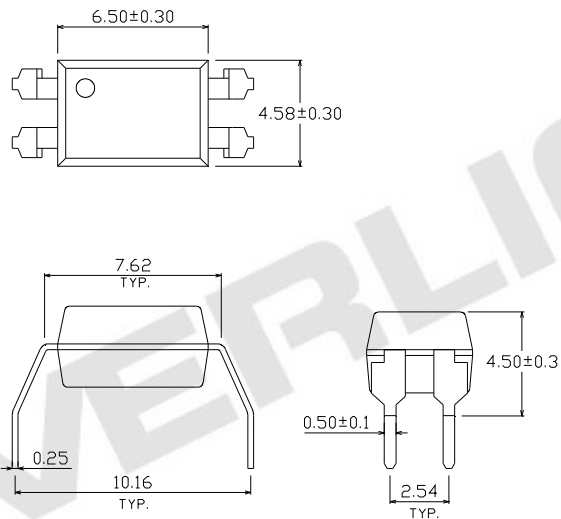

Option S Type

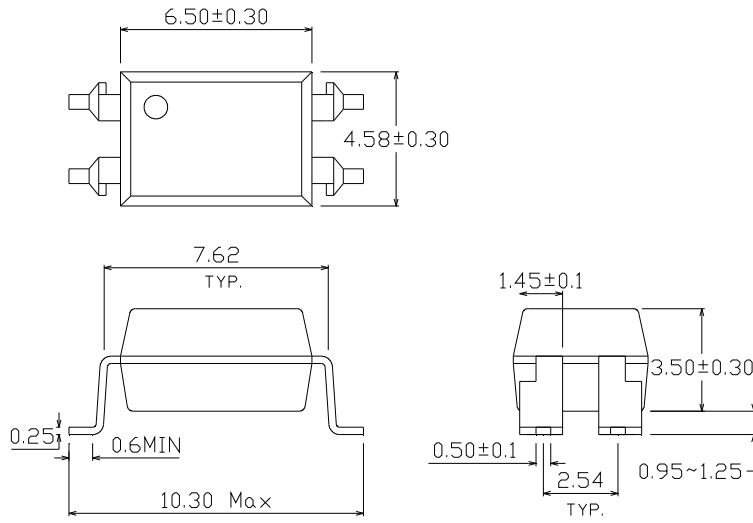

Option S1 Type

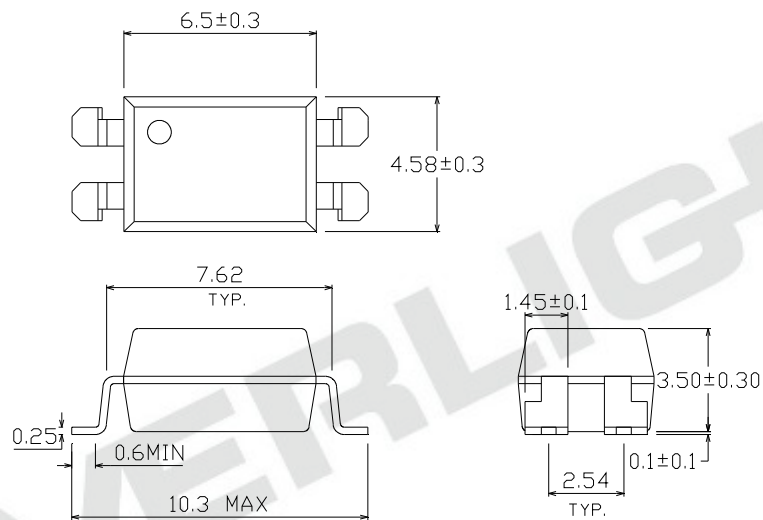



**Recommended pad layout for surface mount leadform**

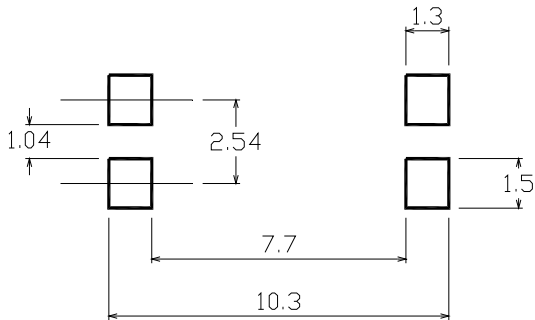

**Device Marking**

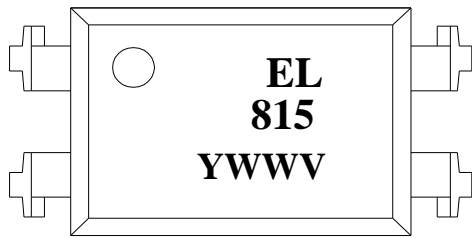

**Notes**

- EL denotes EVERLIGHT
- 815 denotes Device Number
- Y denotes 1 digit Year code
- WW denotes 2 digit Week code
- V denotes VDE optional

**Tape & Reel Packing Specifications**

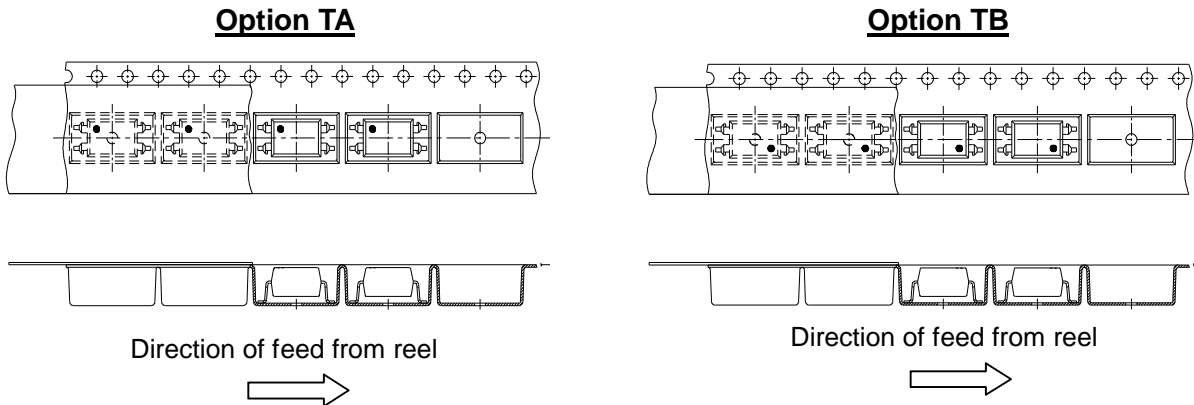

**Tape dimensions**

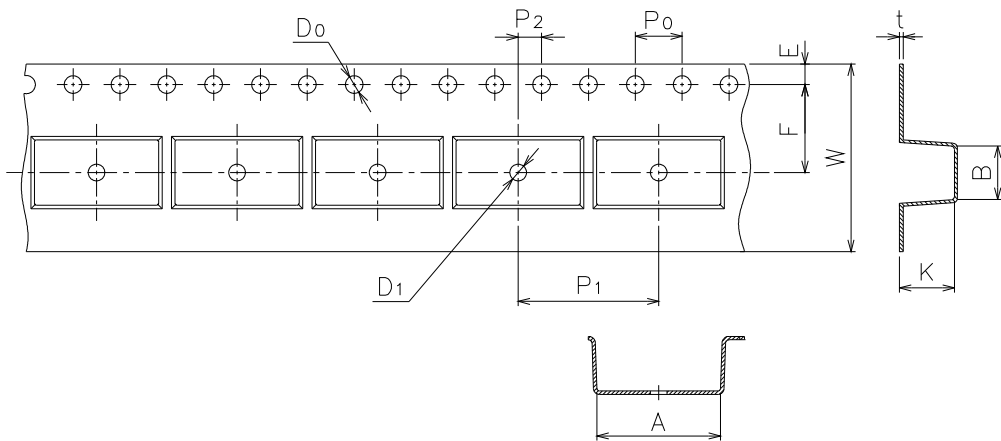

Dimension No.	<b>A</b>	<b>B</b>	<b>Do</b>	<b>D1</b>	<b>E</b>	<b>F</b>
Dimension (mm) S	10.5±0.1	4.65±0.1	1.55±0.1	1.50±0.1	1.75±0.1	7.5±0.1
Dimension (mm) S1	10.5±0.1	4.65±0.1	1.55±0.1	1.50±0.1	1.75±0.1	7.5±0.1
Dimension No.	<b>Po</b>	<b>P1</b>	<b>P2</b>	<b>t</b>	<b>W</b>	<b>K</b>
Dimension (mm) S	4.0±0.1	12.0±0.1	2.0±0.1	0.4±0.1	16.0±0.3	5.05±0.1
Dimension (mm) S1	4.0±0.1	12.0±0.1	2.0±0.1	0.4±0.1	16.0±0.3	4.75±0.1

**Tape & Reel Packing Specifications**

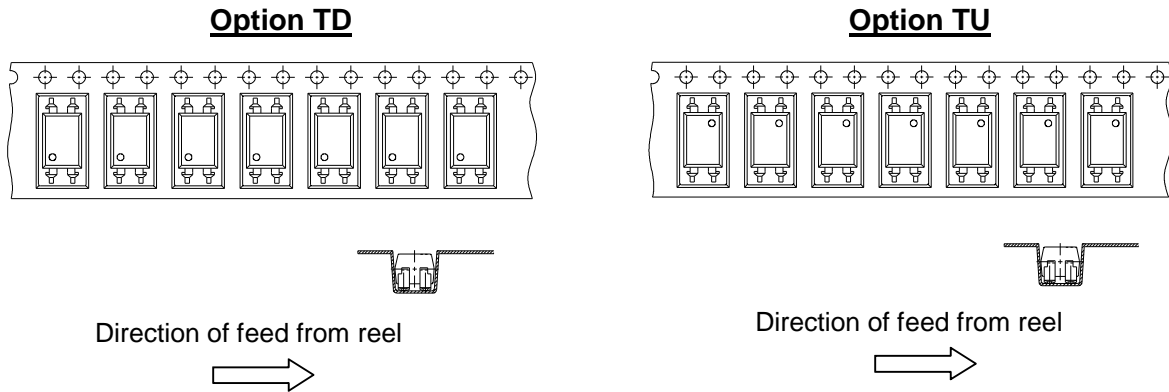

**Tape dimensions**

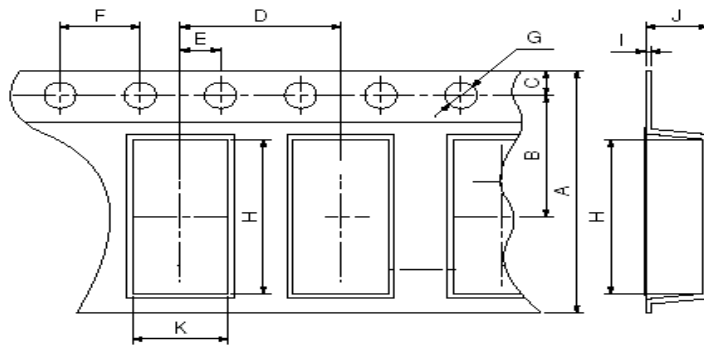

Dimension No.	<b>A</b>	<b>B</b>	<b>C</b>	<b>D</b>	<b>E</b>	<b>F</b>
Dimension(mm)	16.00±0.3	7.5±0.1	1.75±0.1	8.0±0.1	2.0±0.1	4.0±0.1
Dimension No.	<b>G</b>	<b>H</b>	<b>I</b>	<b>J</b>	<b>K</b>	
Dimension(mm)	1.5±0.1	10.4±0.1	0.4±0.1	4.60±0.1	5.1±0.1	

**Precautions for Use**

1. Soldering Condition

1.1 (A) Maximum Body Case Temperature Profile for evaluation of Reflow Profile

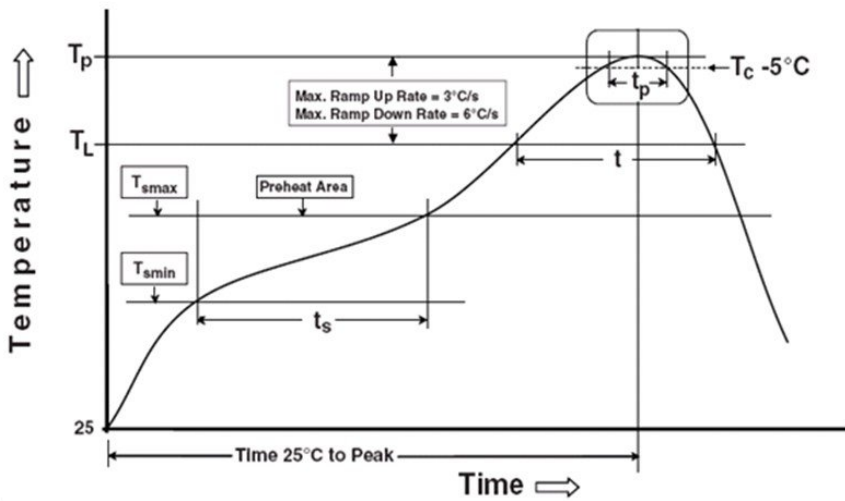

Note:

Reference: IPC/JEDEC J-STD-020D

**Preheat**

Temperature min ( $T_{smin}$ )	150 °C
Temperature max ( $T_{smax}$ )	200°C
Time ( $T_{smin}$ to $T_{smax}$ ) ( $t_s$ )	60-120 seconds
Average ramp-up rate ( $T_{smax}$ to $T_p$ )	3 °C/second max

**Other**

Liquidus Temperature ( $T_L$ )	217 °C
Time above Liquidus Temperature ( $t_L$ )	60-100 sec
Peak Temperature ( $T_p$ )	260°C
Time within 5 °C of Actual Peak Temperature: $T_p - 5°C$	30 s
Ramp- Down Rate from Peak Temperature	6°C /second max.
Time 25°C to peak temperature	8 minutes max.
Reflow times	3 times

## DISCLAIMER

1. Above specification may be changed without notice. EVERLIGHT will reserve authority on material change for above specification.
2. When using this product, please observe the absolute maximum ratings and the instructions for using outlined in these specification sheets. EVERLIGHT assumes no responsibility for any damage resulting from use of the product which does not comply with the absolute maximum ratings and the instructions included in these specification sheets.
3. These specification sheets include materials protected under copyright of EVERLIGHT corporation. Please don't reproduce or cause anyone to reproduce them without EVERLIGHT's consent.

EVERLIGHT

## X-ON Electronics

Largest Supplier of Electrical and Electronic Components

*Click to view similar products for [MOSFET Output Optocouplers](#) category:*

*Click to view products by [Everlight](#) manufacturer:*

Other Similar products are found below :

[TLP3131\(F\)](#) [TLP598GAF](#) [CPC2014NTR](#) [TLP4026G\(F\)](#) [LTV-817S-B](#) [TLP4206G\(F\)](#) [CPC2017NTR](#) [TLP152\(TPL,E\(T](#) [ASSR-601JV-500E](#)  
[PS2505L-4-E3-A](#) [H11AV1XSM](#) [CNY17-1-300E](#) [CNY17-1S](#) [CNY17-2-000E](#) [CNY17-2S](#) [CNY173SR2VM](#) [HCPL-0302-000E](#) [HCPL-181-](#)  
[06DE](#) [HCPL-J312-000E](#) [LTV-3120S-TA1](#) [LTV-817-L](#) [LTV-817M-D](#) [LTV-817S-A](#) [LTV-817S-TA1-L](#) [TIL111](#) [TIL191](#) [MCT6X](#)  
[MCT6XSM](#) [TLP170G\(F\)](#) [TLP197GA\(F\)](#) [TLP197G\(TP,F\)](#) [TLP291\(GR-TP.E\(O](#) [TLP3214\(TP15,F\)](#) [TLP597A\(F\)](#) [TLP797J\(F\)](#) [4N35X](#)  
[4N35XSM](#) [MOC213M](#) [HMHA2801R2](#) [IS357A](#) [ISP521-1X](#) [ISP521-1XSM](#) [ISP620-1XSM](#) [ISP621-4X](#) [ISP621-4XSM](#) [4N25-000E](#)  
[4N26SR2M](#) [4N36M](#) [SFH617A-3XSM](#) [SFH620A-3X](#)