

GN 148

Levelling elements

- **Vibration-damping element (medium)**
Natural rubber NR, hardness 57 ± 5 Shore A, black colour.
- **Sheet metal**
Zinc plated steel, blue passivated.
- **Threaded insert**
Zinc plated steel, blue passivated.
- **Standard executions available**
 - Type **A**: with two hole flange ($d1 = 60 / 90 / 113$).
 - Type **B**: with four-hole flange ($d1 = 113 / 126$).
- **Version**
 - Identification no. **1**: without tear-off lock.
 - Identification no. **2**: with tear-off lock.



Accessories

Rubber pads GN 148.2.

Special executions on request

- Natural rubber NR, hardness 43 ± 5 Shore A.
- Natural rubber NR, hardness 68 ± 5 Shore A.

Features and applications

Levelling elements GN 148 are designed for setting up heavy machinery and units with insulation against vibrations.

This has a positive impact on the lifetime of machines and additionally reduces the noise pollution.

The structure is such that horizontal forces are also absorbed.

The design with tear-off lock (Type 2) protects the levelling feet from destruction caused by tear-off under excessive tension loads.

The details relating to the load bearing capacity are non-binding recommended values and rule out any liability. They constitute no general warranty of quality and condition. The user must determine from case to case whether a product is suitable for the intended use.

Standard Elements	Main dimensions												Δ
Description	d1	d2	d3	d4	d5	h	s	b	l1	l2	m1	m2	g
GN 148-60-M10-A-1-57	60	M10	78	9	-	30	2	78	128	-	110	-	299
GN 148-60-M10-A-2-57	60	M10	78	9	-	30	2	78	128	-	110	-	280
GN 148-90-M12-A-1-57	90	M12	106	13	-	39	3	110	170	-	140	-	725
GN 148-90-M12-A-2-57	90	M12	106	13	-	39	3	110	170	-	140	-	800
GN 148-113-M16-A-1-57	113	M16	150	12.5	-	52	4	150	216	-	184	-	1880
GN 148-113-M16-A-2-57	113	M16	150	12.5	-	52	4	150	216	-	184	-	1890
GN 148-113-M16-B-1-57	113	M16	150	-	12.5	52	4	-	-	168	-	132	1830
GN 148-113-M16-B-2-57	113	M16	150	-	12.5	52	4	-	-	168	-	132	2020
GN 148-126-M20-B-1-57	126	M20	177	-	13	63	4	-	-	184	-	150	2600
GN 148-126-M20-B-2-57	126	M20	177	-	13	63	4	-	-	184	-	150	2900

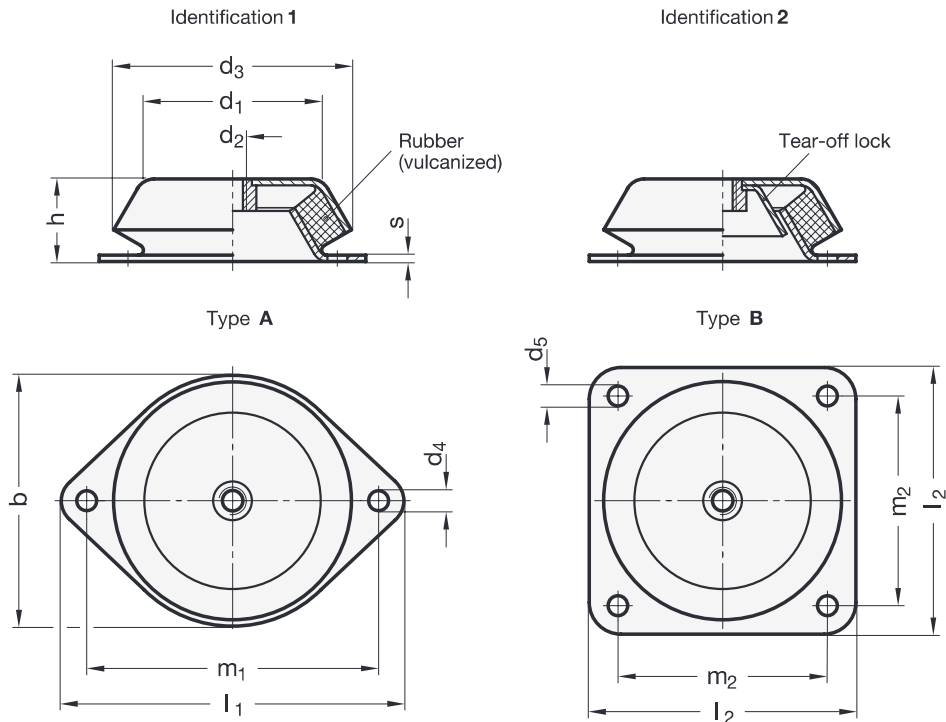

Technical data

- F_1 = static load in vertical direction (pressure)
 F_2 = static load in horizontal direction (lateral thrust)
 s_1 = Compression in vertical direction (spring excursion under load through F_1)
 s_2 = Compression in vertical direction (spring excursion) under load through F_2

Stiffness R:
is the load which causes the damping elements to be compressed by 1 mm (spring rate)

$$\text{Equation for calculating the stiffness: } R = \frac{F}{s}$$

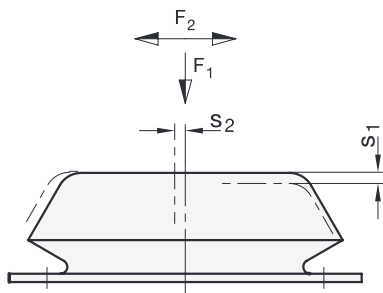

The table below gives details on the maximum static load F , the maximum rated compression and the resulting stiffness R .

The method shown on page 22 and the values given below allow the maximum degree of insulation of the vibration to be determined as factor of the interference frequency.

d_1	Hardness in Shore	max. static load F_1 in N	Stiffness R_1 in N/mm	max. compression s_1 in mm	max. static load F_2 in N	Stiffness R_2 in N/mm	max. compression s_2 in mm
60	43*	1100	340	3.2	2300	770	3
60	57	1750	550	3.2	3400	1130	3
60	68*	2800	930	3	4000	1330	3
90	43*	1500	430	3.5	3000	750	4
90	57	2800	800	3.5	5000	1330	3.75
90	68*	4500	1290	3.5	7000	1870	3.75
113	43*	3500	1000	3.5	4500	1290	3.5
113	57	6500	1860	3.5	7500	2140	3.5
113	68*	10000	2860	3.5	11000	3140	3.5
126	43*	7500	2140	3.5	9000	2570	3.5
126	57	12500	3570	3.5	15000	4290	3.5
126	68*	19000	5340	3.5	22500	6430	3.5

* not available from stock, requires a minimum order quantity

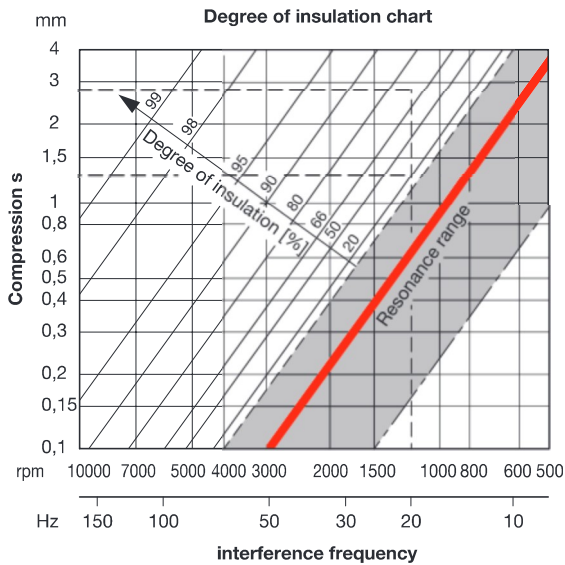

Technical data

Interference frequency [Hz]:
is the frequency emanating from a machine, e.g. the machine main shaft speed [rpm].

Static load F [N]:
is the load acting on each vibration-damping element (levelling element).

Degree of insulation [%]:
is the measure for absorbing the interference frequency (damping).

Compression s [mm]:
is the change in height of the damping element (spring excursion).

Stiffness R [N/mm]:
is the load which causes a damping element to be compressed by 1 mm (spring rate).

First, the static load F for each levelling element must be determined. For well arranged levelling elements and the resulting even distribution of the load F , the static load is calculated using the following equation:

$$\frac{\text{Weight force of the machine [N]}}{\text{number of levelling elements}} = \text{static load } F \text{ [N]} / \text{per levelling element}$$

Once the static load F has been calculated, select a levelling element from the table. Please note that the static load F should be as close as possible to the static load capacity, but without exceeding it. The associated stiffness R of the selected leg is also shown in the table.

The actual compression is then calculated using the equation below.

$$\frac{\text{Static load } F \text{ [N]} / \text{per levelling elements}}{\text{stiffness } R \text{ [N/mm]}} = \text{actual compression } s \text{ [mm]}$$

Starting from the actual compression s calculated, the maximum degree of insulation as factor of the interference frequency can now be read in the above chart.

To optimise the maximum degree of insulation, change the number of feet such that the static load F of each levelling element is as close as possible below a static load capacity value given in the table. This will increase the compression s which, in turn, improves the degree of insulation.

In general, medium and high frequencies can be very well insulated with an adequate compression.

Application example

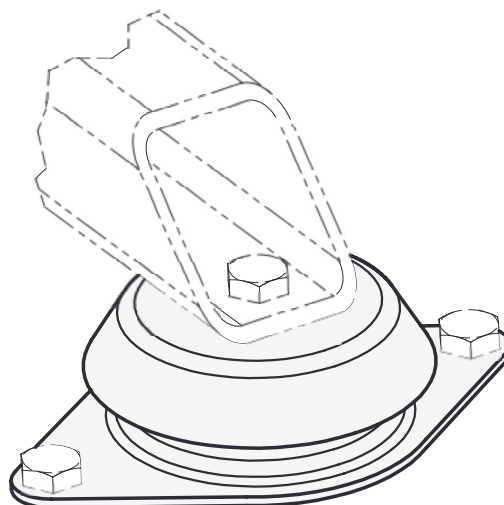

X-ON Electronics

Largest Supplier of Electrical and Electronic Components

Click to view similar products for [Mounting Fixings](#) category:

Click to view products by [Elesa & Ganter](#) manufacturer:

Other Similar products are found below :

[5912235-2](#) [007310](#) [007541](#) [6-141-P](#) [620HA038NF09](#) [620HA038NF11](#) [CTJ420E028-513](#) [M81714/60-12-01](#) [M81714/60-22-01](#) [L/C](#)
[MA1EAF1200](#) [70-584649-01P](#) [71-074914-006](#) [71-215091-8S](#) [712HA170B23128-N](#) [71-344699-4S](#) [71-441549-19S](#) [71-441864-5S](#) [71-](#)
[490451-4H](#) [EX-13-3-B-16-325PN](#) [75-69116-8S](#) [75-69211-3P](#) [75-69220-27S](#) [75-69224-5S](#) [75-69614-2S](#) [770-006A109](#) [770-006A109R](#) [770-](#)
[006A207](#) [770-006A208W1](#) [770-006A209](#) [770-006A306](#) [770-006A703W1](#) [770-006A704](#) [770-006A704W1](#) [770-006A705](#) [770-006A706](#)
[770-006A706W1](#) [770-006A707](#) [770-006A709](#) [770-007A203](#) [770-007A203W1](#) [770-007A204W1](#) [770-007A207W1](#) [770-007A703](#) [770-](#)
[007A704W1](#) [770-007A706](#) [770-007A707W1](#) [770-010Y208](#) [770-010Y308](#) [770-010Y705](#) [770-010Y706](#)