

Display Elektronik GmbH

DATA SHEET

TFT MODULE

DEM 800480N TMH-PW-N

(C-TOUCH)

7,0“ TFT + PCT

Product Specification

Ver.: 1

01.09.2014

Contents

	Page
1. Revision History	3
2. General Specification	4
3. Interface	6
4. Drawing	8
5. Block Diagram	9
6. Absolute Maximum Ratings	10
7. Electrical Characteristics	11
8. DC Characteristics	11
9. Data input Characteristics	12
10. Optical Specifications	14
11. Reliability	16
12. Touch Panel Information	17

1. Revision History

DATE	VERSION	REVISED PAGE NO.	Note
01.09.2014	0		Preliminary
01.09.2014	1		First Issue

2. General Specification

This technical specification applies to 7.0' color TFT-LCD panel. The 7.0' color TFT-LCD panel is designed for camcorder, digital camera application and other electronic products which require high quality flat panel displays. This module follows RoHS.

- Resolution: 800 x RGB x 480
- Module Size: 165.00 x 100.00 x 7.30 (max.) mm
- Active Area : 154.08 x 85.92 mm
- Dot Pitch: 0.0642 x 0.179 mm
- LCD Type: TFT, Normally White, Transmissive
- View Direction: 12 o'clock
- Gray Scale Inversion Direction: 6 o'clock
- Backlight Type: LED, Normally White
- Integrated Capacitive Touch-Panel

*Color tone slight changed by temperature and driving voltage.

3. Interface

LCM PIN Definition

Pin	Symbol	Function	Remark
1	A	Power supply for backlight	
2	A	Power supply for backlight	
3	K	Backlight ground	
4	K	Backlight ground	
5	GND	Power ground	
6	VCOM	Common voltage	
7	VCC	Power for Digital Circuit	
8	MODE	DE/SYNC mode select	Note 1
9	DE	Data Input Enable	
10	VS	Vertical Sync Input	
11	HS	Horizontal Sync Input	
12	B7	Blue data(MSB)	
13	B6	Blue data	
14	B5	Blue data	
15	B4	Blue data	
16	B3	Blue data	
17	B2	Blue data	
18	B1	Blue data	Note 2
19	B0	Blue data(LSB)	Note 2
20	G7	Green data(MSB)	
21	G6	Green data	
22	G5	Green data	
23	G4	Green data	
24	G3	Green data	
25	G2	Green data	
26	G1	Green data	Note 2
27	G0	Green data(LSB)	Note 2
28	R7	Red data(MSB)	
29	R6	Red data	
30	R5	Red data	
31	R4	Red data	
32	R3	Red data	
33	R2	Red data	
34	R1	Red data	Note 2
35	R0	Red data(LSB)	Note 2
36	GND	Power Ground	
37	DCLK	Sample clock	Note 3
38	GND	Power Ground	
39	L/R	Left / right selection	Note 4,5
40	U/D	Up/down selection	Note 4,5
41	VGH	Gate ON Voltage	
42	VGL	Gate OFF Voltage	
43	AVDD	Power for Analog Circuit	
44	RESET	Global reset pin.	Note 6
45	NC	No connection	
46	VCOM	Common Voltage	

47	DITHB	Dithering function	Note 7
48	GND	Power Ground	
49	NC	No connection	
50	NC	No connection	

I: input, O: output, P: Power

Note 1: DE/SYNC mode select. Normally pull high.

When select DE mode, MODE="1", VS and HS must pull high.

When select SYNC mode, MODE="0", DE must be grounded.

Note 2: When input 18 bits RGB data, the two low bits of R,G and B data must be grounded.

Note 3: Data shall be latched at the falling edge of DCLK.

Note 4: Selection of scanning mode

Setting of scan control		Scanning direction
U/D	L/R	
GND	VCC	Up to down, left to right
VCC	GND	Down to up, right to left
GND	GND	Up to down, right to left
VCC	VCC	Down to up, left to right

Note 5: Definition of scanning direction.

Refer to the figure as below:

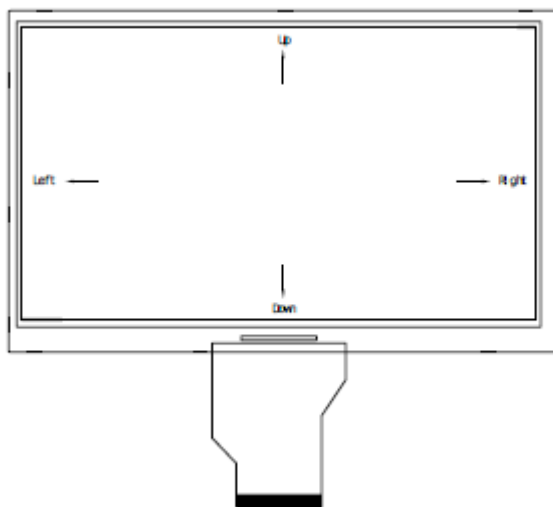

Note 6: Global reset pin. Active low to enter reset state . Suggest to connect with an RC reset circuit for stability. Normally pull high.

Note 7: Dithering function enable control, normally pull high.

When DITHB="1", Disable internal dithering function,

When DITHB="0", Enable internal dithering function,

4. Drawing

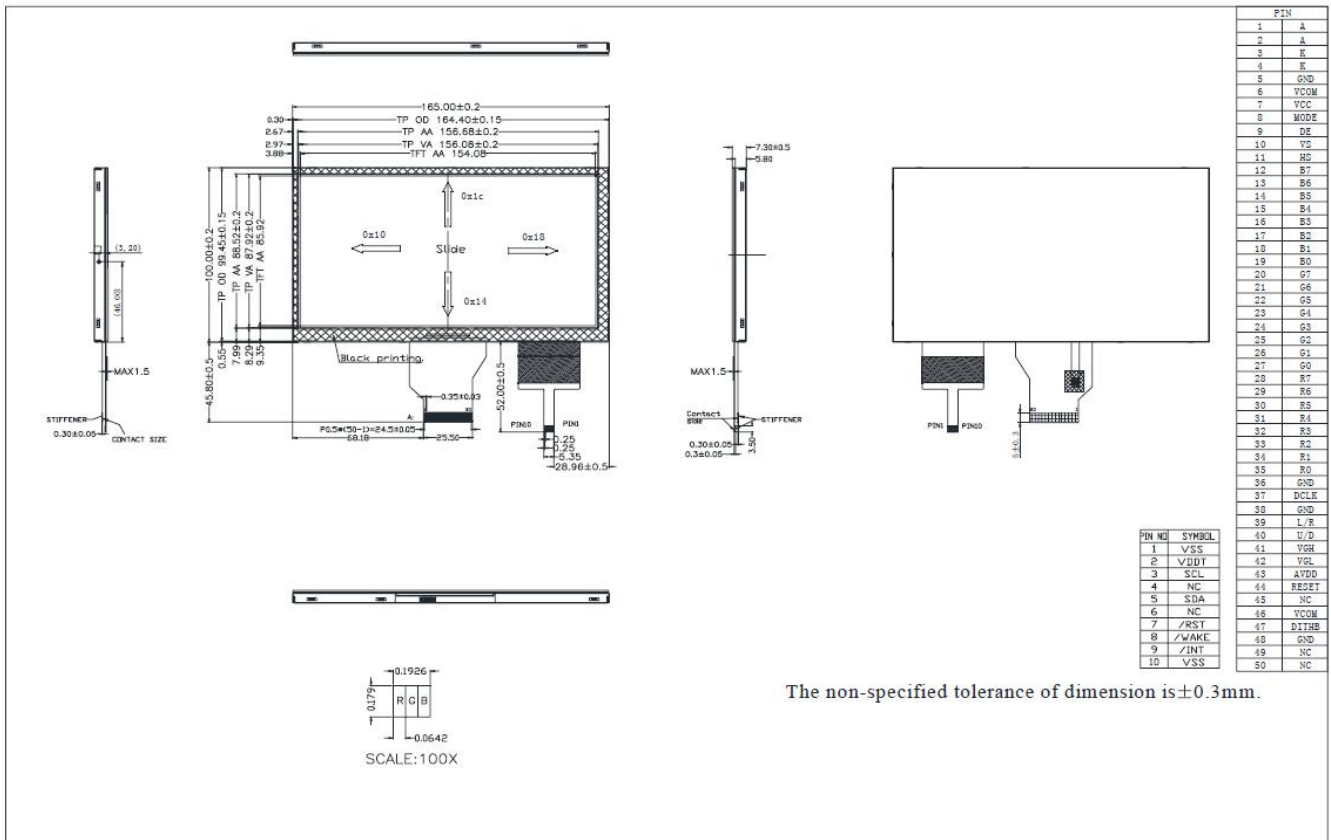

5. BLOCK DIAGRAM

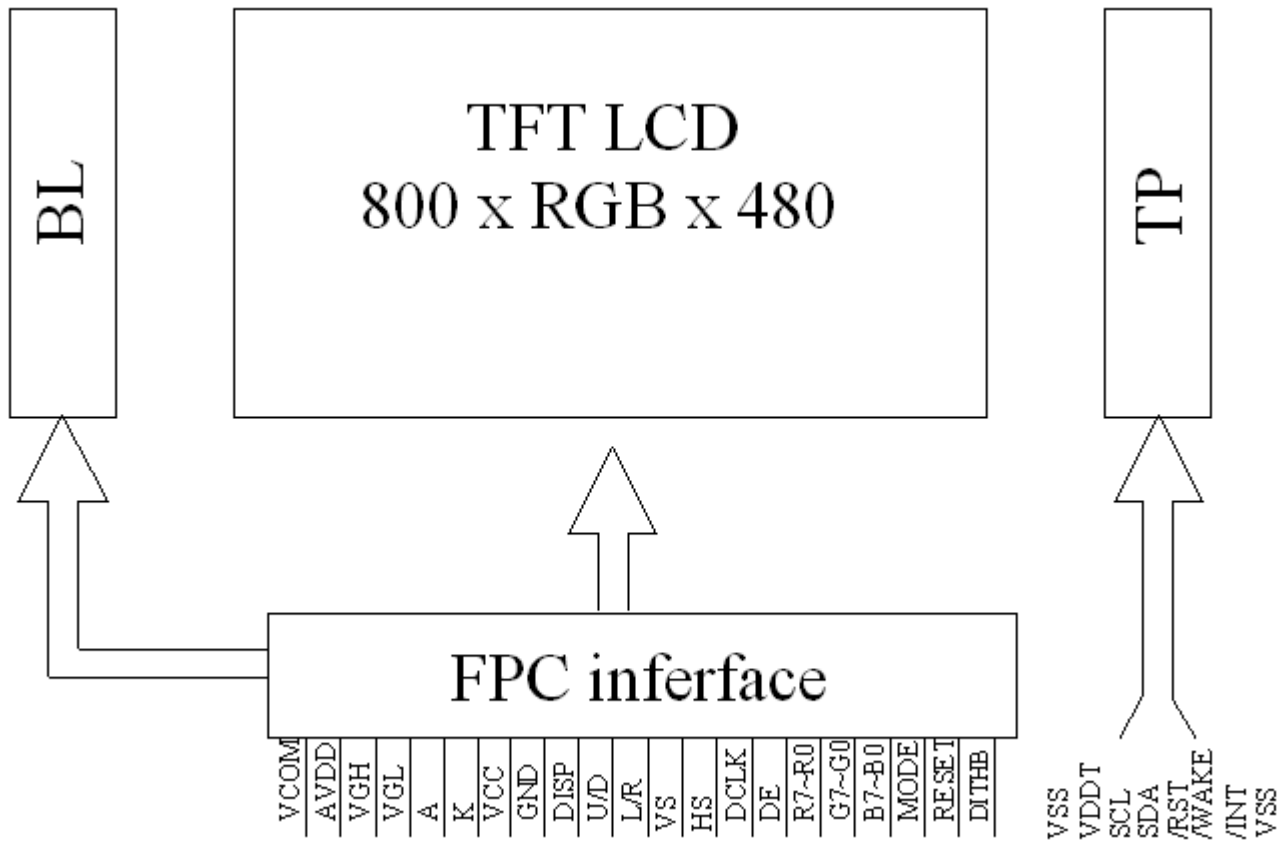

4

6. Absolute Maximum Ratings

Item	Symbol	Min	Typ	Max	Unit
Operating Temperature	TOP	-20	—	+70	°C
Storage Temperature	TST	-30	—	+80	°C

Note: Device is subject to be damaged permanently if stresses beyond those absolute maximum ratings listed above

- Temp. $\leq 60^{\circ}\text{C}$, 90% RH MAX. Temp. $> 60^{\circ}\text{C}$, Absolute humidity shall be less than 90% RH at 60°C

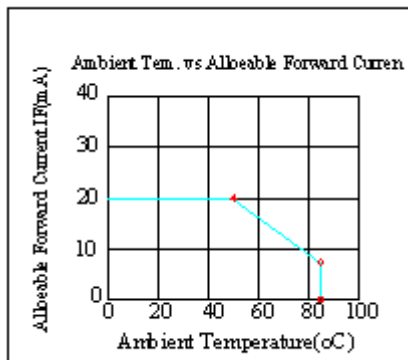

7. Electrical Characteristics

7.1 Operating conditions:

Item	Symbol	Min	Typ	Max	Unit	Remark
Digital Power Supply Voltage	VCC	3.0	3.3	3.6	V	
Supply Voltage For Touch Logic	VDDT	2.8	—	3.3	V	
Analog Power Supply Voltage	AVDD	—	10.4	10.6	V	
Gate On Power Supply Voltage	VGH	15.3	16.0	16.7	V	
Gate Off Power Supply Voltage	VGL	-7.7	-7.0	-6.3	V	
Common Power Supply Voltage	VCOM	—	(3.6)	—	V	Note1

Note1.Please adjust VCOM to make the flicker level be minimum.

7.2 LED driving conditions

Parameter	Symbol	Min.	Typ.	Max.	Unit	Remark
LED current	-	175	180	190	mA	-
LED voltage	A~K	8.8	9.6	10.5	V	Note 1
LED Life Time	-	20,000	-	-	Hr	Note 2,3,4

Note 1 : There are 1 Groups LED

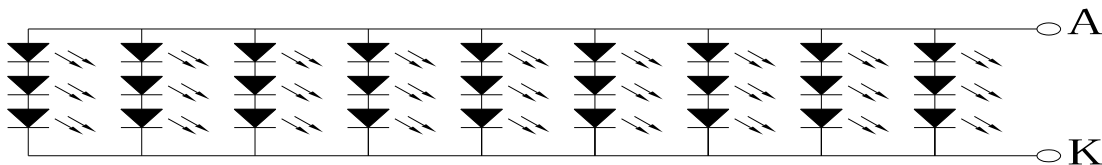

Backlight LED Circuit

Note 2 : Ta = 25°C

Note 3 : Brightness to be decreased to 50% of the initial value

Note 4 : The single LED lamp case

8. DC CHARATERISTICS

Parameter	Symbol	Rating			Unit	Condition
		Min	Typ	Max		
Low level input voltage	V _{IL}	0	-	0.3VCC	V	
High level input voltage	V _{IH}	0.7VCC	-	VCC	V	

9. Data Input Characteristics

9.1 Timing Characteristics of Input Signals

Item	Symbol	Values			Unit	Remark
		Min.	Typ.	Max.		
Horizontal Display Area	thd	—	800	—	DCLK	
DCLK Frequency	fclk	26.4	33.3	46.8	MHz	
One Horizontal Line	th	862	1056	1200	DCLK	
HS pulse width	thpw	1	—	40	DCLK	
HS Blanking	thb	46	46	46	DCLK	
HS Front Porch	thfp	16	210	354	DCLK	

Item	Symbol	Values			Unit	Remark
		Min.	Typ.	Max.		
Vertical Display Area	tvd	—	480	—	TH	
VS period time	tv	510	525	650	TH	
VS pulse width	tvpw	1	—	20	TH	
VS Blanking	tvb	23	23	23	TH	
VS Front Porch	tvfp	7	22	147	TH	

9.2 Input Clock and Data Timing Diagram

Item	Symbol	Values			Unit	Remark
		Min.	Typ.	Max.		
HS setup time	T_{hst}	8	—	—	ns	
HS hold time	T_{hhd}	8	—	—	ns	
VS setup time	T_{vst}	8	—	—	ns	
VS hold time	T_{vhd}	8	—	—	ns	
Data setup time	T_{dsu}	8	—	—	ns	
Data hole time	T_{dhd}	8	—	—	ns	
DE setup time	T_{esu}	8	—	—	ns	
DE hole time	T_{ehd}	8	—	—	ns	
DV _{DD} Power On Slew rate	T_{POR}	—	—	20	ms	From 0 to 90% DV _{DD}
RESET pulse width	T_{Rs}	1	—	—	ms	
DCLK cycle time	T_{coh}	20	—	—	ns	
DCLK pulse duty	T_{cwh}	40	50	60	%	

9.3 Data Input Format

24-bit Parallel RGB Interface

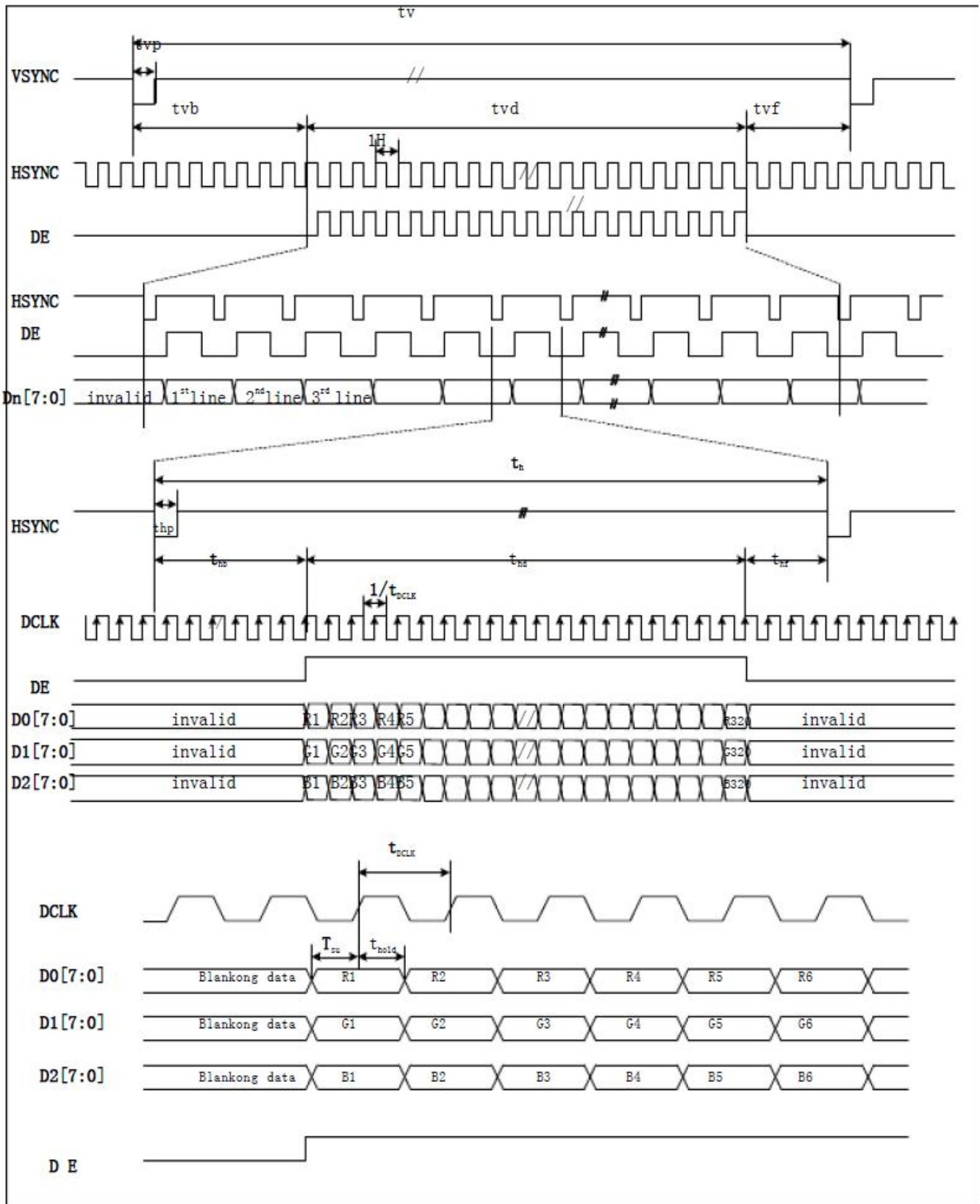

10. OPTICAL CHARACTERISTIC

Item	Symbol	Condition.	Min	Typ.	Max.	Unit	Remark
Response Time	Tr	$\theta=0^\circ, \phi=0^\circ$	-	10	20	.ms	Note 3
	Tf		-	15	30	.ms	
Contrast Ratio	CR	At optimized viewing angle	400	500	-	-	Note 4
Color Chromaticity	White	Wx	0.26	0.31	0.36	-	Note 2,5,6
		Wy	0.28	0.33	0.38	-	
Viewing angle	Hor.	θ_R	60	70	-	Deg.	Note 1
		θ_L	60	70	-		
	Ver.	ϕ_T	40	50	-		
		ϕ_B	60	70	-		
Brightness	-	-	280	320	-	cd/m ²	Center of display

Ta=25±2°C, IL=180mA

Note 1: Definition of viewing angle range

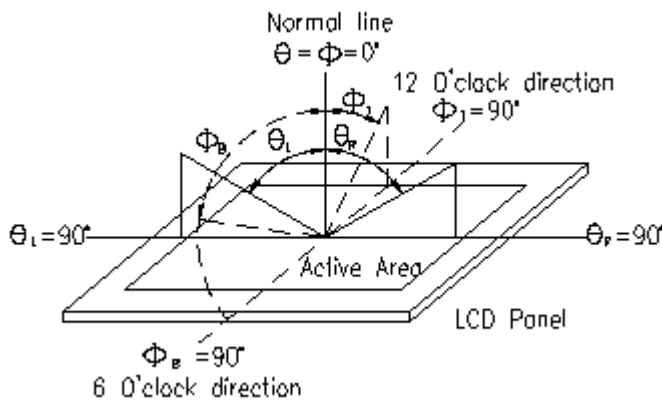

Fig. 11.1. Definition of viewing angle

Note 2: Test equipment setup:

After stabilizing and leaving the panel alone at a driven temperature for 10 minutes, the measurement should be executed. Measurement should be executed in a stable, windless, and dark room. Optical specifications are measured by Topcon BM-7 or BM-5 luminance meter 1.0° field of view at a distance of 50cm and normal direction.

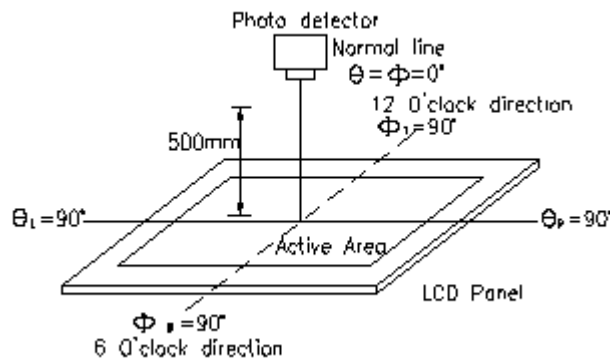
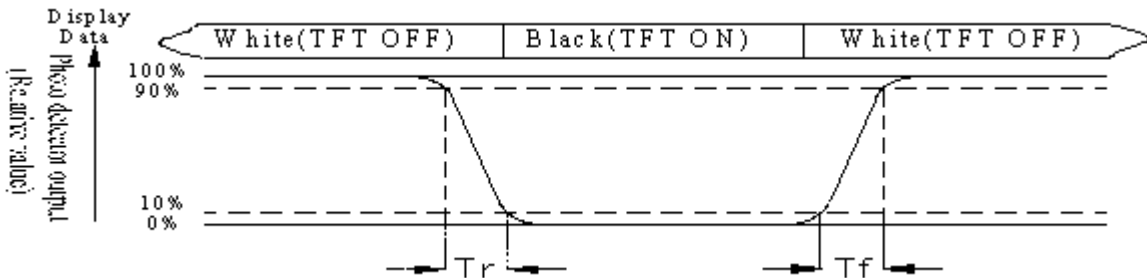

Fig. 11.2. Optical measurement system setup

Note 3: Definition of Response time:

The response time is defined as the LCD optical switching time interval between “White” state and “Black” state. Rise time, Tr, is the time between photo detector output intensity changed from 90%to 10%. And fall time, Tf, is the time between photo detector output intensity changed from 10%to 90%



Note 4: Definition of contrast ratio:

The contrast ratio is defined as the following expression.

$$\text{Contrast ratio (CR)} = \frac{\text{Luminance measured when LCD on the "White" state}}{\text{Luminance measured when LCD on the "Black" state}}$$

Note 5: White Vi = Vi50 ± 1.5V

Black Vi = Vi50 ± 2.0V

“±” means that the analog input signal swings in phase with VCOM signal.

“±” means that the analog input signal swings out of phase with VCOM signal.

The 100% transmission is defined as the transmission of LCD panel when all the input terminals of module are electrically opened.

Note 6: Definition of color chromaticity (CIE 1931)

Color coordinates measured at the center point of LCD

Note 7: Measured at the center area of the panel when all the input terminals of LCD panel are electrically opened.

$$\text{Note 8: Uniformity (U)} = \frac{\text{Brightness(m in)}}{\text{Brightness(m ax)}} 100\%$$

11. Reliability

Content of Reliability Test (Wide temperature, -20°C~70°C)

Environmental Test			
Test Item	Content of Test	Test Condition	Note
High Temperature storage	Endurance test applying the high storage temperature for a long time.	80° C 200hrs	2
Low Temperature storage	Endurance test applying the low storage temperature for a long time.	-30° C 200hrs	1,2
High Temperature Operation	Endurance test applying the electric stress (Voltage & Current) and the thermal stress to the element for a long time.	70° C 200hrs	—
Low Temperature Operation	Endurance test applying the electric stress under low temperature for a long time.	-20° C 200hrs	1
High Temperature/ Humidity Operation	The module should be allowed to stand at 60° C,90%RH max For 96hrs under no-load condition excluding the polarizer, Then taking it out and drying it at normal temperature.	60° C,90%RH 96hrs	1,2
Thermal shock resistance	The sample should be allowed stand the following 10 cycles of operation <div style="text-align: center;"> <p style="margin: 0;">-20° C 25° C 70° C</p> <p style="margin: 0;">30min 5min 30min</p> <p style="margin: 0;">1 cycle</p> </div>	-20° C/70° C 10 cycles	—
Vibration test	Endurance test applying the vibration during transportation and using.	Total fixed amplitude : 15mm Vibration Frequency : 10~55Hz One cycle 60 seconds to 3 directions of X,Y,Z for Each 15 minutes	3
Static electricity test	Endurance test applying the electric stress to the terminal.	C=150pF,R=330Ω,5point/panel Air:±8Kv,5times; Contact:±4Kv, 5times (Environment:15° C~35° C, 30%~60%.86Kpa~106Kpa)	—

Note1: No dew condensation to be observed.

Note2: The function test shall be conducted after 4 hours storage at the normal Temperature and humidity after remove from the test chamber.

Note3: The packing have to including into the vibration testing.

12. Touch Panel Information

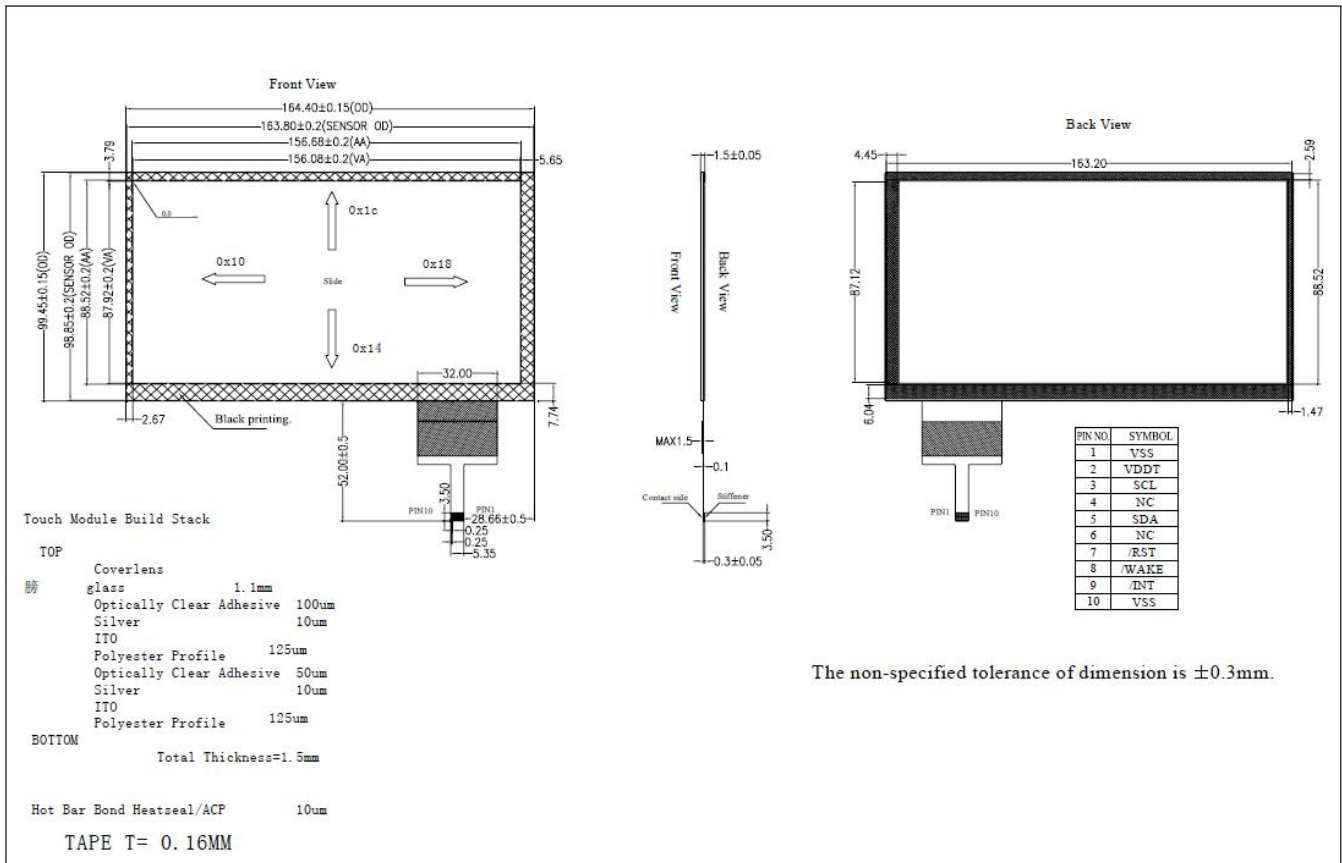

12.1 Capacitive Touch Panel I2C Timing:

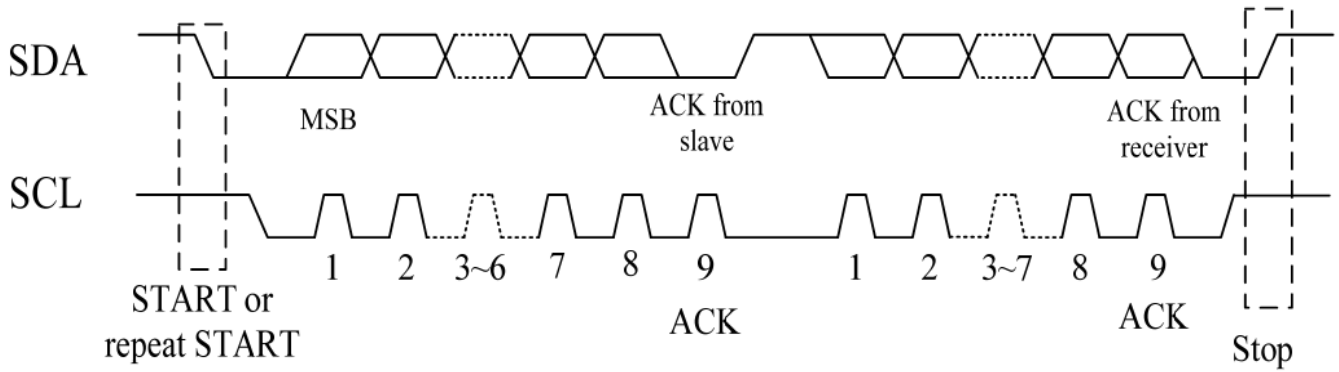

I2C Serial Data Transfer Format

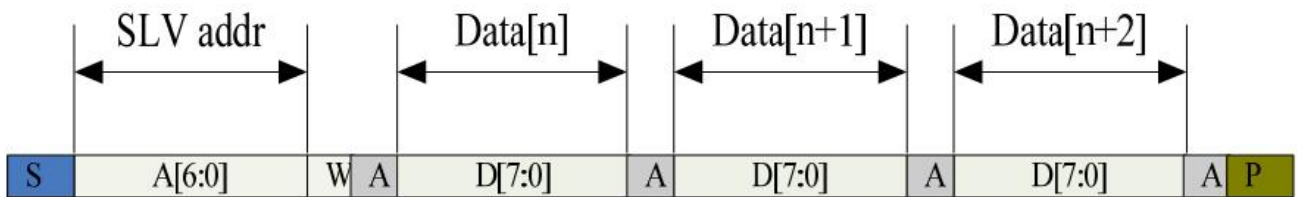

I2C master write, slave read

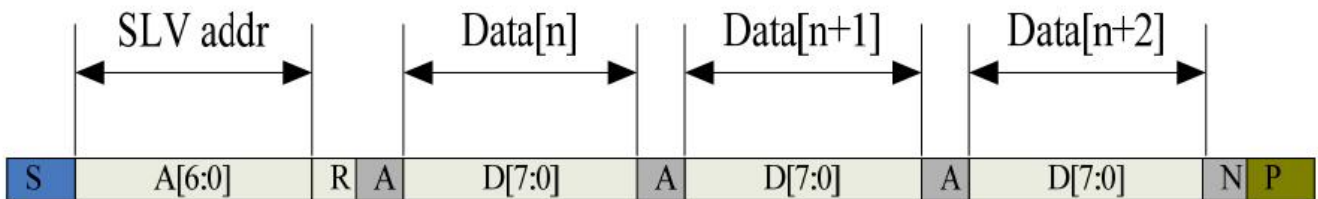

I2C master read, slave write

Mnemonics	Description
S	12C Start or 12C Restart
A[6:0]	Slave address A[6:4]:3'b011 A[3:0]:data bits are identical to those of 12CCON[7:4]register
W	1'b0:Write
R	1'b1:Read
A(N)	ACK(NACK)
P	STOP :the indication of the end of a packet(if this bit is missing, S will indicate the end of the current packet and beginning of the next packet)

Lists the meanings of the mnemonics used in the above figures

Parameter	Unit	Min	Max
SCL frequency	KHz	0	400
Bus free time between a STOP and START condition	us	4.7	\
Hold time (repeated) ST ART condition	us	4.0	\
Data setup time	ns	250	\
Setup time for a repeated START condition	us	4.7	\
Setup time for STOP condition	us	4.0	\

Interface Timing Characteristics

AS FOR STANDARD CTPM, HOST NEED TO USE BOTH INTERRUPT CONTROL SIGNAL AND SERIAL DATA INTERFACE TO GET THE TOUCH DATA.

HERE IS THE TIMING TO GET TOUCH DATA.

12.2 WRITE BYTES TO I2C SLAVE

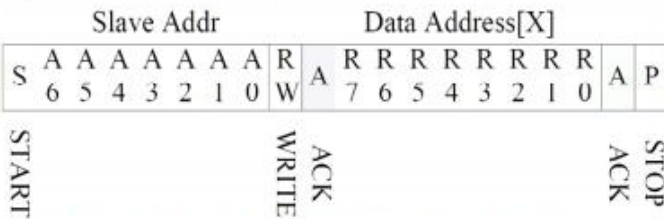
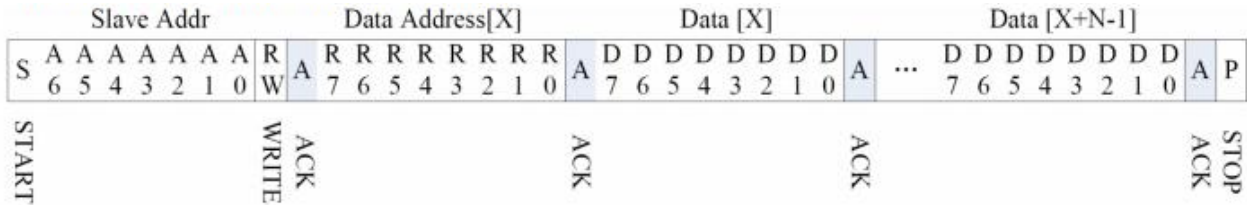

READ X BYTES FROM I2C SLAVE

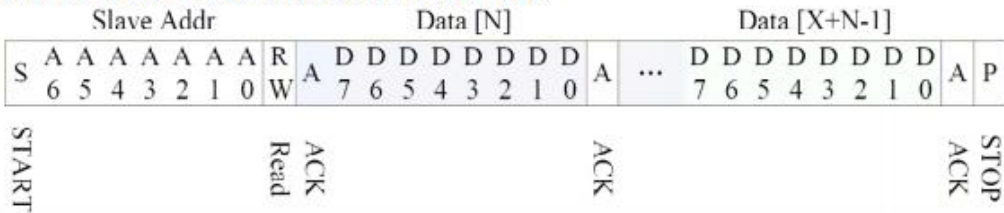

AS FOR STANDARD CTPM, HOST NEED TO USE BOTH INTERRUPT CONTROL SIGNAL AND SERIAL DATA INTERFACE TO GET THE TOUCH DATA, HERE IS THE TIMING TO GET TOUCH DATA.

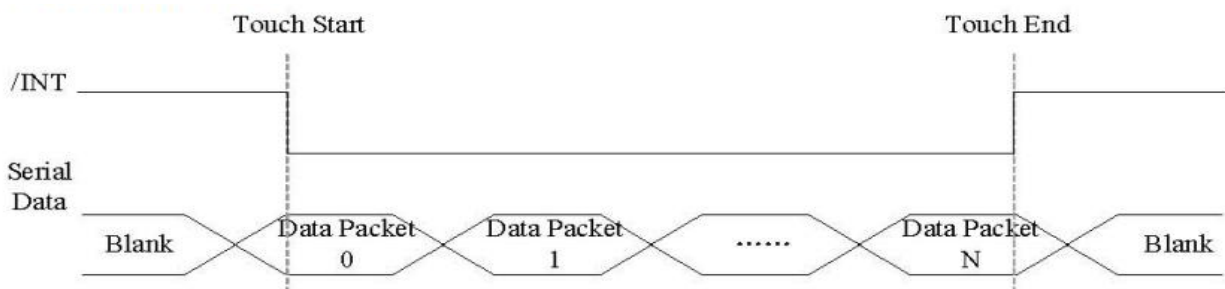

Address: 0X38

TOUCH DATA READ PROTOCOL

NAME	VALUE	DESCRIPTION
START CH	0X00	START COMMAND FOR CTPM TOUCH DATA PACKET,HOST MUST SEND CTPM A START CH COMMAND BEFORE READ TOUCH DATA
1st READ BYTE~ LAST READ BYTE		TOUCH DATA PACKET SENT BY CTPM,EACH BYTE HAS 8-BIT DATA ,A TOUCH DATA PACKET CONSISTS OF N BYTE

A DATA PACKET STARTS WITH A HEADER AND ENDS WITH CRC CODE,AS FOR 5 POINTS DATA PACKET,THE LENGTH OF THE PACKET IS ALWAYS 26 BYTES IN SPITE OF ACTUAL TOUCH POINTS.

Address	Name	Bit7	Bit6	Bit5	Bit4	Bit3	Bit2	Bit1	Bit0	Host Access
00h	Devide__Mode		Device Model[2:0]							RW
01h	Gest__ID	Gesture ID[7:0]								R
02h	TD__Status					Number of touch points[3:0]				R
03h	Touch1__XH	1 st Event Flag				1 st Touch X Position[11:8]				R
04h	Touch1__XL	1 st Touch X Position[7:0]								R
05h	Touch1__YH	1 st Touch ID[3:0]				1 st Touch Y Position[11:8]				R
06h	Touch1__YL	1 st Touch Y Position[7:0]								R
09h	Touch2__XH	2 nd Event Flag				2 nd Touch X Position[11:8]				R
0Ah	Touch2__XL	2 nd Touch X Position[7:0]								R
0Bh	Touch2__YH	2nd Touch ID[3:0]				2ndTouch Y Position[11:8]				R
0Ch	Touch2__YL	2nd Touch Y Position[7:0]								R
0Fh	Touch3__XH	3rdEvent Flag				3rdTouch X Position[11:8]				R
10h	Touch3__XL	3rd Touch X Position[7:0]								R
11h	Touch3__YH	3rdTouch ID[3:0]				3rdTouch Y Position[11:8]				R
12h	Touch3__YL	3rd Touch Y Position[7:0]								R
15h	Touch4__XH	4thEvent Flag				4thTouch X Position[11:8]				R
16h	Touch4__XL	4th Touch X Position[7:0]								R
17h	Touch4__YH	4thTouch ID[3:0]				4thTouch Y Position[11:8]				R
18h	Touch4__YL	4th Touch Y Position[7:0]								R
1Bh	Touch5__XH	5thEvent Flag				5thTouch X Position[11:8]				R
1Ch	Touch5__XL	5th Touch X Position[7:0]								R
1Dh	Touch5__YH	5thTouch ID[3:0]				5thTouch Y Position[11:8]				R
1Eh	Touch5__YL	5th Touch Y Position[7:0]								R

X-ON Electronics

Largest Supplier of Electrical and Electronic Components

Click to view similar products for [TFT Displays & Accessories](#) category:

Click to view products by [Display Elektronik](#) manufacturer:

Other Similar products are found below :

[OAI-80038AA-2013-A](#) [HDA430T-3G1H](#) [EA CARREDIPTFT02](#) [NL6448BC20-21D](#) [NB7W-KBA04](#) [NB-ATT01](#) [NB5Q-ATT01](#) [NB5Q-KBA04](#) [NB-CN001](#) [NL12880BC20-05](#) [NL8060BC26-35C](#) [NL8060BC26-35F](#) [TCG104SVLQAPNN-AN20](#) [OAI-80038AA-2008-A](#) [315-U004B15300](#) [UMSH-8596MD-34T \(REV D\)](#) [98-0003-3490-8](#) [1044278](#) [1029309](#) [1060549](#) [DE 127-TU-30/7,5](#) [DE 128-TU-20/7,5](#) [EP-LK007TFTPCAP](#) [FR7.0A00](#) [RC2002A-TIG-CSX](#) [NL6448BC2021C](#) [TX17D01VM2EAB](#) [TX14D23VM5BAA](#)
[TCG121WXLRXVNNANX35](#) [EIC-LCD-1080P](#) [T272480C07VR01](#) [1060632](#) [TCG070WVLPAANN-AN50](#) [TCG035QVLPDANN-GN50](#)
[1060630](#) [RFE430V-AIW-DNG](#) [T-55619GD065J-LW-ABN](#) [NHD-1.8-128160EF-SSXN-FT](#) [TCG104SVLPEANN-AN30](#) [NL6448BC33-70](#)
[NL192108BC18-06F](#) [NLB150XG02L-01](#) [NL6448BC20-30D](#) [NL10276BC16-06](#) [NL192108AC10-01D](#) [NL6448AC18-08F](#) [NL6448BC20-30F](#)
[NL12880BC20-05BD](#) [NL12880BC20-05D](#) [NL8060BC26-35BA](#)