

FEATURES

- 6.95V Shunt Reference
- Guaranteed 0.5ppm/°C Temperature Coefficient
- Guaranteed 1Ω Maximum Dynamic Impedance
- Guaranteed 20μV_{RMS} Maximum Noise
- Guaranteed Initial Tolerance of 2%
- Wide Operating Current Range
- Available in 4-Lead TO-46 Metal Can

APPLICATIONS

- Precision Voltage Reference for Multimeters
- Calibration Equipment Voltage Standards
- Laboratory Measurement Equipment
- Industrial Monitor/Control Instruments
- High Accuracy Data Converters

DESCRIPTION

The LM199/LM399 precision shunt reference features excellent temperature stability over a wide range of voltage, temperature and operating current conditions. A stabilizing heater is incorporated with the active Zener on a monolithic substrate which nearly eliminates changes in voltage with temperature. The subsurface Zener operates over a current range of 0.5mA to 10mA, and offers minimal noise and excellent long-term stability.

Ideal applications for the LM199/LM399 include digital voltmeters, precision calibration equipment, current sources and a variety of other precision low cost references. A 10V buffered reference application is shown below.

LT, LTC and LT are registered trademarks of Linear Technology Corporation. All other trademarks are the property of their respective owners.

TYPICAL APPLICATION

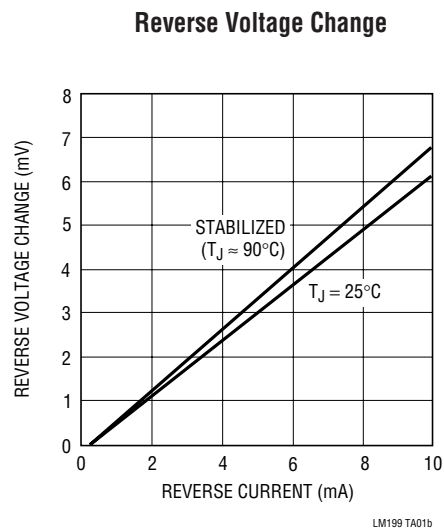
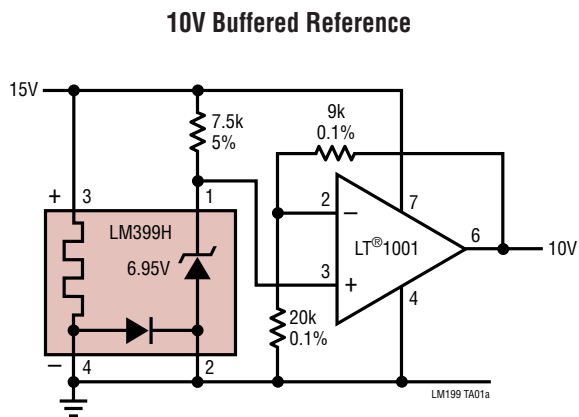

LM199/LM399

LM199A/LM399A

ABSOLUTE MAXIMUM RATINGS

(Note 1)

Temperature Stabilizer	40V
Reverse Breakdown Current.....	20mA
Forward Current.....	1mA
Reference to Substrate Voltage, V_{RS} (Note 2).....	-0.1V
Operating Temperature Range	
LM199/LM199A (OBSOLETE).....	-55°C to 125°C
LM399/LM399A.....	0°C to 70°C
Storage Temperature Range	
LM199/LM199A (OBSOLETE).....	-65°C to 150°C
LM399/LM399A.....	-65°C to 150°C
Lead Temperature (Soldering, 10 sec)	300°C

PACKAGE/ORDER INFORMATION

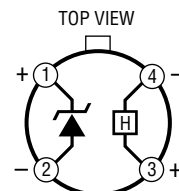

H PACKAGE
4-LEAD TO-46 METAL CAN
INSIDE THERMAL SHIELD

ORDER PART NUMBER

LM399H
LM399AH

LM199H
LM199AH
LM199AH-20
LM399AH-20
LM399AH-50
OBSOLETE

Order Options Tape and Reel: Add #TR
Lead Free: Add #PBF Lead Free Tape and Reel: Add #TRPBF
Lead Free Part Marking: <http://www.linear.com/leadfree/>

Consult LTC Marketing for parts specified with wider operating temperature ranges.

ELECTRICAL CHARACTERISTICS

The ● denotes the specifications which apply over the full operating temperature range, otherwise specifications are at $T_A = 25^\circ\text{C}$. (Note 3)

SYMBOL	PARAMETER	CONDITIONS	LM199/LM199A			LM399/LM399A			UNITS	
			MIN	TYP	MAX	MIN	TYP	MAX		
V_Z	Reverse Breakdown Voltage	$0.5\text{mA} \leq I_R \leq 10\text{mA}$	●	6.8	6.95	7.1	6.75	6.95	7.3	V
ΔV_Z	Reverse Breakdown Voltage Change with Current	$0.5\text{mA} \leq I_R \leq 10\text{mA}$	●		6	9		6	12	mV
r_Z	Reverse Dynamic Impedance	$I_R = 1\text{mA}$ (Note 6) ($10\text{Hz} \leq f \leq 100\text{Hz}$)	●		0.5	1		0.5	1.5	Ω
$\frac{\Delta V_Z}{\Delta \text{Temp}}$	Temperature Coefficient LM199/LM399	$-55^\circ\text{C} \leq T_A \leq 85^\circ\text{C}$ $85^\circ\text{C} \leq T_A \leq 125^\circ\text{C}$ $0^\circ\text{C} \leq T_A \leq 70^\circ\text{C}$			0.3	1				ppm/ $^\circ\text{C}$
	LM199A/LM399A	$-55^\circ\text{C} \leq T_A \leq 85^\circ\text{C}$ $85^\circ\text{C} \leq T_A \leq 125^\circ\text{C}$ $0^\circ\text{C} \leq T_A \leq 70^\circ\text{C}$			0.2	0.5		0.3	2	ppm/ $^\circ\text{C}$
e_n	RMS Noise	$10\text{Hz} \leq f \leq 10\text{kHz}$	●		7	20		7	50	μV
$\frac{\Delta V_Z}{\Delta \text{Time}}$	Long-Term Stability	Stabilized, $22^\circ\text{C} \leq T_A \leq 28^\circ\text{C}$, 1000 Hours, $I_R = 1\text{mA} \pm 0.1\%$			8	(Note 4)		8	(Note 4)	ppm/ $\sqrt{\text{kHz}}$
I_H	Temperature Stabilizer Supply Current	$T_A = 25^\circ\text{C}$, Still Air, $V_H = 30\text{V}$ $T_A = -55^\circ\text{C}$ (Note 5)			8.5	14		8.5	15	mA
V_H	Temperature Stabilizer Supply Voltage		●		9	40		9	40	V
	Warm-Up Time to $\pm 0.05\% V_Z$	$V_H = 30\text{V}$			3			3		Seconds
	Initial Turn-On Current	$9\text{V} \leq V_H \leq 40\text{V}$ (Note 5)			140	200		140	200	mA

LM199399fb

ELECTRICAL CHARACTERISTICS

Note 1: Absolute Maximum Ratings are those values beyond which the life of a device may be impaired.

Note 2: The substrate is electrically connected to the negative terminal of the temperature stabilizer. The voltage that can be applied to either terminal of the reference is 40V more positive or 0.1V more negative than the substrate.

Note 3: These specifications apply for 30V applied to the temperature stabilizer and $-55^{\circ}\text{C} \leq T_A \leq 125^{\circ}\text{C}$ for the LM199; and $0^{\circ}\text{C} \leq T_A \leq 70^{\circ}\text{C}$ for the LM399.

Note 4: Devices with maximum guaranteed long-term stability of 20ppm/ $\sqrt{\text{kH}}$ are available. Drift decreases with time.

Note 5: This initial current can be reduced by adding an appropriate resistor and capacitor to the heater circuit. See the Typical Performance Characteristics graphs to determine values.

Note 6: Guaranteed by "Reverse Breakdown Change with Current."

TYPICAL PERFORMANCE CHARACTERISTICS

Reverse Characteristics

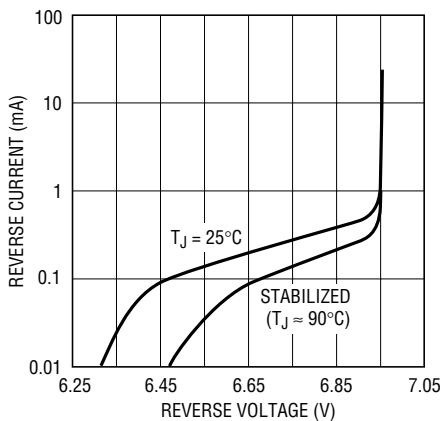

LM199 G01

Dynamic Impedance

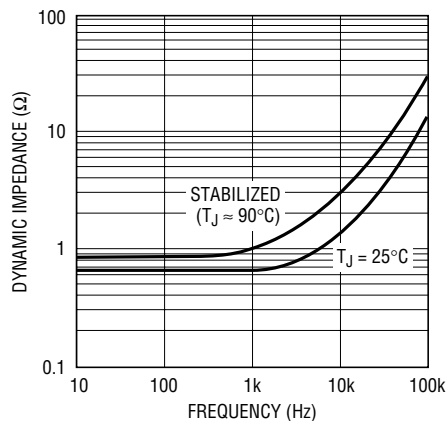

LM199 G02

Stabilization Time

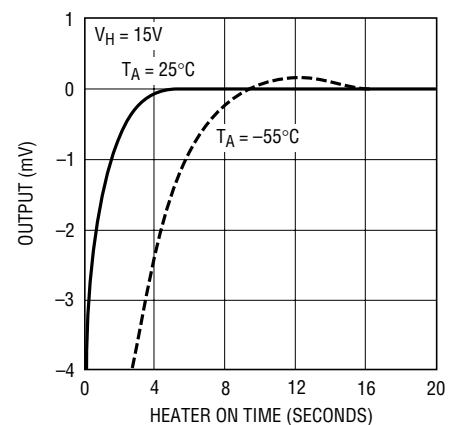

LM199 G03

Initial Heater Current

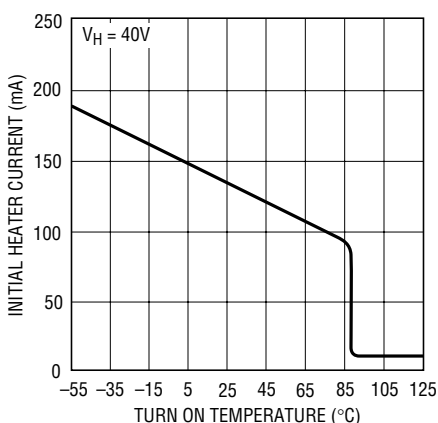

LM199 G04

Heater Current

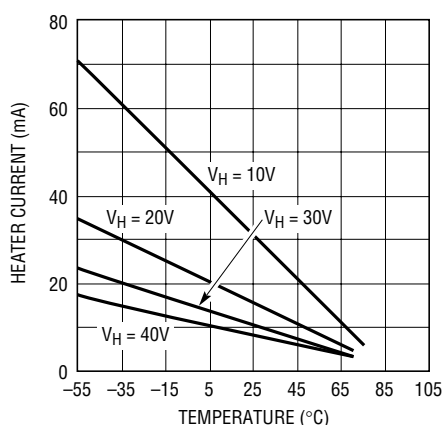

LM199 G05

Heater Current

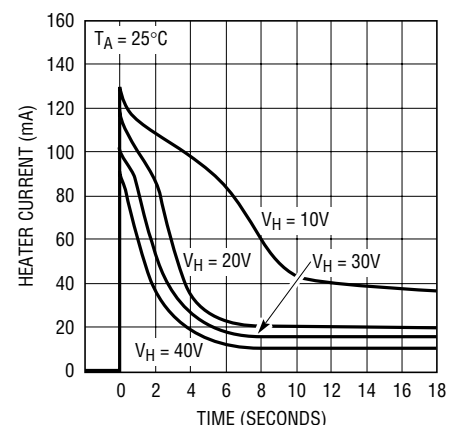

LM199 G06

TYPICAL PERFORMANCE CHARACTERISTICS

Zener Noise Voltage

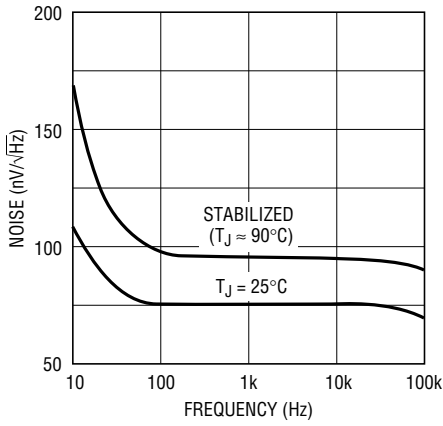

Response Time

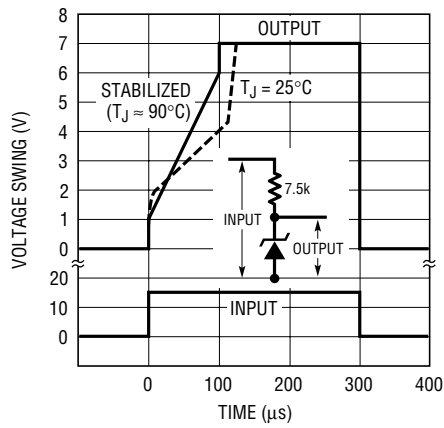

Limiting Surge Current

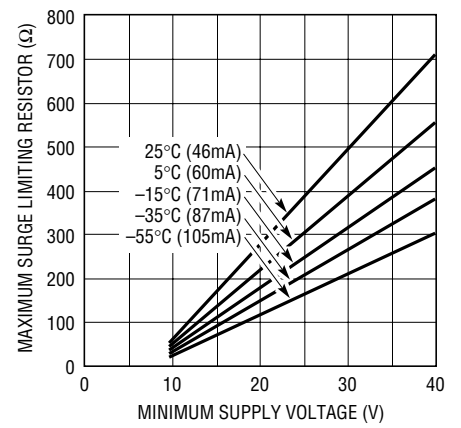

Long-Term Reference Performance, 44 Units Tested

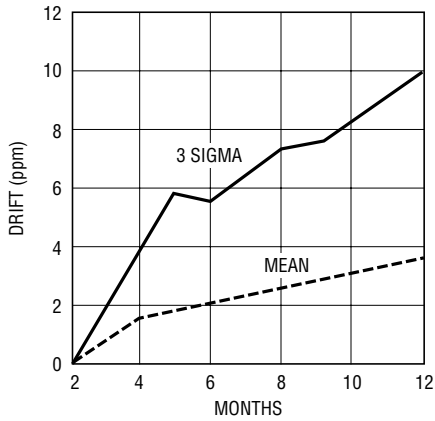

Low Frequency Noise Voltage

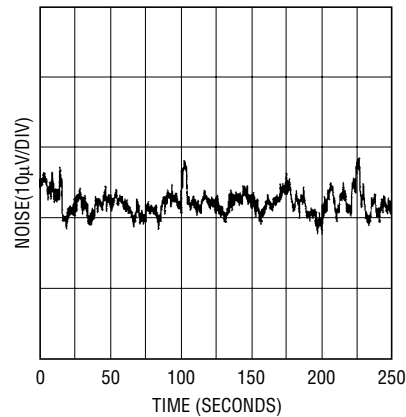

FUNCTIONAL BLOCK DIAGRAM

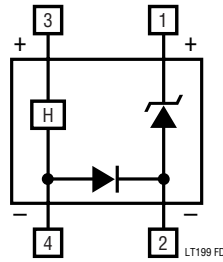

TYPICAL APPLICATIONS

Single Supply Operation

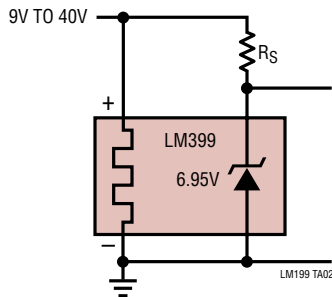

Split Supply Operation

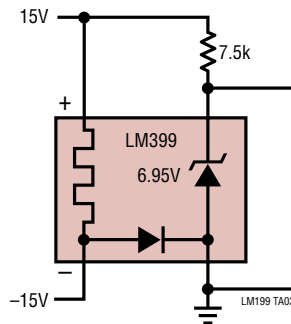

Negative Heater Supply with Positive Reference

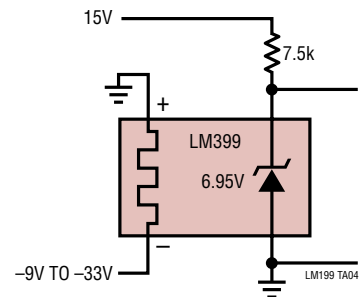

Standard Cell Replacement

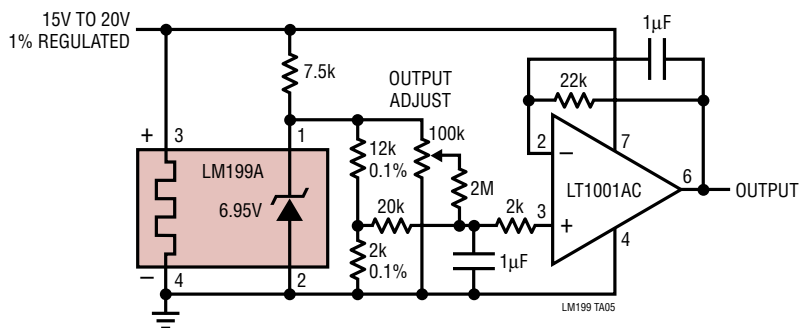

TYPICAL APPLICATIONS

Portable Calibrator

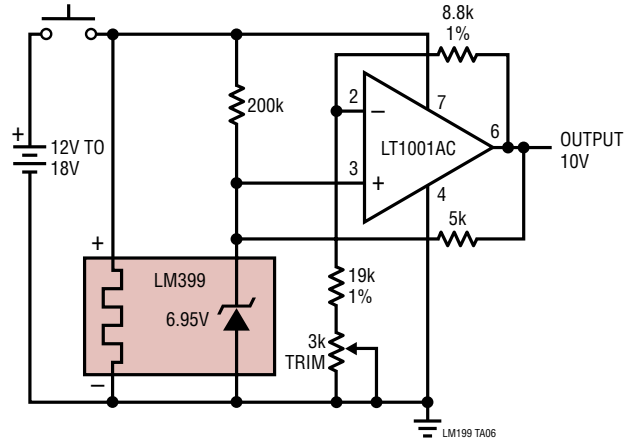

SCHEMATIC DIAGRAMS

Temperature Stabilizer

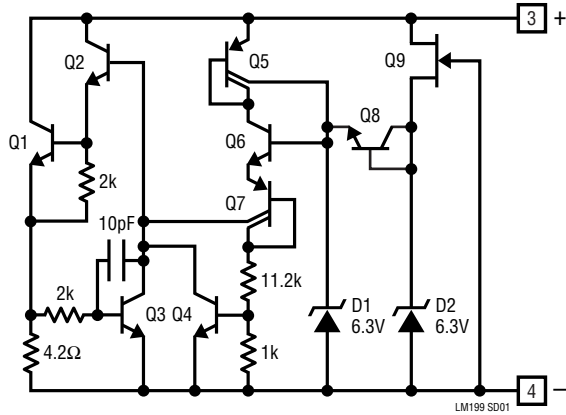

Reference

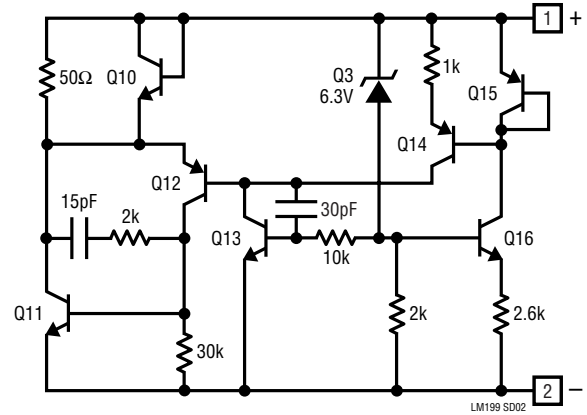

PACKAGE DESCRIPTION

H Package
4-Lead TO-46 Metal Can
(Reference LTC DWG # 05-08-1341)

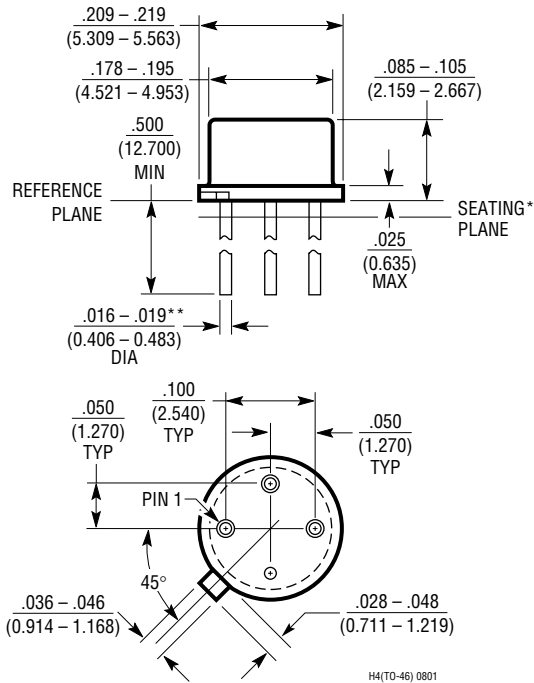

*LEAD DIAMETER IS UNCONTROLLED BETWEEN THE REFERENCE PLANE AND .050" BELOW THE REFERENCE PLANE

**FOR SOLDER DIP LEAD FINISH, LEAD DIAMETER IS $\frac{.016 - .024}{(0.406 - 0.610)}$

Thermal Shield* for TO-46, H Package

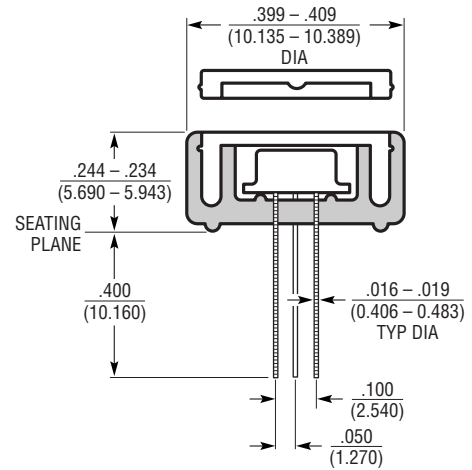

* THERMAL SHIELD MATERIAL IS VALOX™.
VALOX IS A TRADEMARK OF GENERAL ELECTRIC

LM199/LM399 LM199A/LM399A

RELATED PARTS

PART NUMBER	DESCRIPTION	COMMENTS
LT1021	Precision References for Series or Shunt Operation	Industry Standard Pinout, -40°C to 125°C
LT1389	1.25V, 2.5V, 4V and 5V Nanopower Shunt Reference	800nA, 0.05% Accuracy, 10ppm/°C Drift
LT1634	1.25 and 2.5V Micropower Shunt Reference	0.05%, 10ppm/°C, 10µA Current
LTZ1000	7V Ultra Precision, Stable Shunt Reference	0.05ppm/°C, 1.2mV _{p-p} Noise

X-ON Electronics

Largest Supplier of Electrical and Electronic Components

Click to view similar products for [Voltage References](#) category:

Click to view products by [Analog Devices](#) manufacturer:

Other Similar products are found below :

[622664A](#) [636116E](#) [748389C](#) [AS431ARTR-E1](#) [NCP431BCSNT1G](#) [NCP432BCSNT1G](#) [NCV431BSNT1G](#) [AP4313UKTR-G1](#)
[TL1431AIYDT](#) [AZ431BR-ATRE1](#) [622668D](#) [NCP432BVSNT1G](#) [712504A](#) [TLV431CSN1T1G](#) [5962-8686103XC](#) [NCV431BVDMR2G](#)
[LT1460JCS3-2.5#TRMPBF](#) [LT1460JCS3-3.3#TRMPBF](#) [LT6654AMPS6-3.3#TRMPBF](#) [LT6654AMPS6-3#TRMPBF](#) [LT1460KCS3-3#TRMPBF](#) [LT1460KCS3-2.5#TRMPBF](#) [LT1004CZ-2.5#TRPBF](#) [LT1460HCS3-3.3#TRMPBF](#) [AZ432BNTR-G1](#) [LT1460HCS3-5#TRMPBF](#)
[LT1460HCS3-2.5#TRMPBF](#) [AP4306BUKTR-G1](#) [LT6654AMPS6-2.5#TRMPBF](#) [SC431BVSNT1G](#) [MAX6023EBT30+T](#) [LT1460KCS3-3.3#TRMPBF](#) [NCV431ASNT1G](#) [LTC6655BHLS8-5#PBF](#) [LT6657AHMS8-1.25#PBF](#) [LT1460HCS3-3#TRMPBF](#) [LT1027DILS8-5#PBF](#)
[LM4040CEM3-5.0/V+T](#) [LT1009CZ#TRPBF](#) [LT6654BHS6-2.048#TRMPBF](#) [LT1460KCS3-3#TRM](#) [LT1460KCS3-3.3#TRM](#) [LT6660KCDC-10#TRMPBF](#) [LTC6652AHLS8-5#PBF](#) [LTC6652BHLS8-5#PBF](#) [LM336Z-2.5#PBF](#) [LTC6655CHLS8-4.096#PBF](#) [SC431ILPRAG](#)
[TLVH431MIL3T](#) [MAX6023EBT21+T](#)