

## THREE TERMINAL POSITIVE VOLTAGE REGULATOR

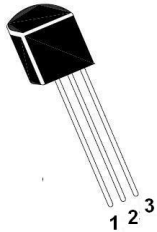

1. OUT
2. GND
3. IN

**LM78L09**  
**TO-92**  
**Plastic Package**

### Features

Maximum Output Current  $I_{OM} = 0.1A$

Output Voltage  $V_o = 9V$

Continuous total dissipation  $P_D = 0.625W$

### MAXIMUM RATINGS (Operating temperature range applies unless otherwise specified)

PARAMETERS	SYMBOL	VALUE	UNIT
Input Voltage	$V_I$	30	V
Operating Junction Temperature Range	$T_{OPR}$	0 to 125	°C
Storage Temperature Range	$T_{STG}$	-55 to 150	°C

### ELECTRICAL CHARACTERISTICS ( $V_i = 16V$ , $I_o = 40mA$ , $C_i = 0.33\mu F$ , $C_o = 0.1\mu F$ , unless otherwise specified)

PARAMETER	SYMBOL	TEST CONDITION		MIN.	TYP.	MAX.	UNIT
Output voltage	$V_o$		25°C	8.64	9.0	9.36	V
		$12 \leq V_i \leq 24V$ , $I_o = 1mA-40mA$	0-125°C	8.55	9.0	9.45	V
		$I_o = 1mA-70mA$		8.55	9.0	9.45	V
Load Regulation	$\Delta V_o$	$I_o = 1mA-100mA$	25°C	-	19	90	mV
		$I_o = 1mA-40mA$	25°C	-	11	40	mV
Line Regulation	$\Delta V_o$	$12V \leq V_i \leq 24V$	25°C	-	45	175	mV
		$13V \leq V_i \leq 24V$	25°C	-	40	125	mV
Quiescent Current	$I_q$		25°C	-	4.1	6.0	mA
Quiescent Current Change	$\Delta I_q$	$13V \leq V_i \leq 24V$	0-125°C	-	-	1.5	mA
		$1mA \leq I_o \leq 40mA$	0-125°C	-	-	0.1	mA
Output Noise Voltage	$V_N$	$10Hz \leq f \leq 100kHz$	25°C	-	58	-	$\mu V$
Ripple Rejection	RR	$15V \leq V_i \leq 25V$ , $f = 120Hz$	0-125°C	-	45	-	dB
Dropout Voltage	$V_d$		25°C	-	1.7	-	V

### TYPICAL APPLICATION

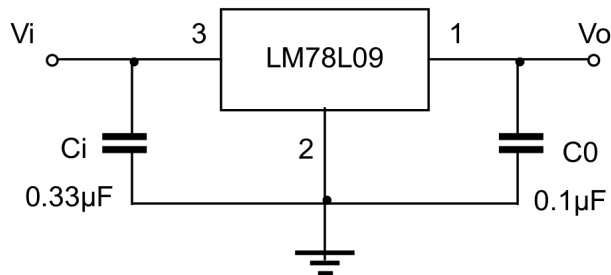

**Note:** Bypass capacitors are recommended for optimum stability and transient response and should be located as close as possible to the regulators.

### TO-92 PACKAGE OUTLINE AND DIMENSIONS

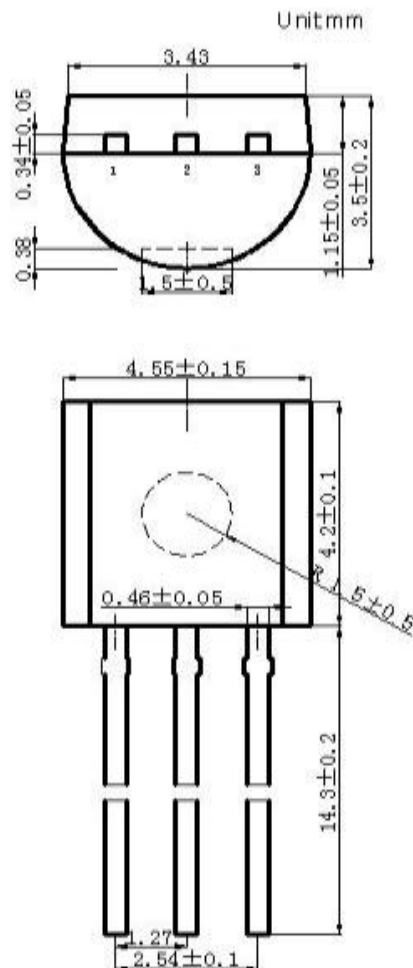

- 1. OUT
- 2. GND
- 3. IN

### Customer Notes:



Continental Device India Pvt. Limited  
An ISO/TS 16949, ISO 9001 and ISO 14001 Certified Company



## Component Disposal Instructions

1. CDIL Semiconductor Devices are RoHS compliant, customers are requested to please dispose as per prevailing Environmental Legislation of their Country.
2. In Europe, please dispose as per EU Directive 2002/96/EC on Waste Electrical and Electronic Equipment (WEEE).

## DISCLAIMER

The product information and the selection guides facilitate selection of the CDIL's Semiconductor Device(s) best suited for application in your product(s) as per your requirement. It is recommended that you completely review our Data Sheet(s) so as to confirm that the Device(s) meet functionality parameters for your application. The information furnished in the Data Sheet and on the CDIL Web Site/CD is believed to be accurate and reliable. CDIL however, does not assume responsibility for inaccuracies or incomplete information. Furthermore, CDIL does not assume liability whatsoever, arising out of the application or use of any CDIL product; neither does it convey any license under its patent rights nor rights of others. These products are not designed for use in life saving/support appliances or systems. CDIL customers selling these products (either as individual Semiconductor Devices or incorporated in their end products), in any life saving/support appliances or systems or applications do so at their own risk and CDIL will not be responsible for any damages resulting from such sale(s).



CDIL is a registered Trademark of  
Continental Device India Pvt. Limited  
C-120 Naraina Industrial Area, New Delhi 110 028, India.  
Telephone + 91-11-2579 6150, 4141 1112 Fax + 91-11-2579 5290, 4141 1119  
email@cdil.com www.cdil.com  
CIN No. U32109DL1964PTC004291

# X-ON Electronics

Largest Supplier of Electrical and Electronic Components

*Click to view similar products for [Linear Voltage Regulators](#) category:*

*Click to view products by [CDIL](#) manufacturer:*

Other Similar products are found below :

[LV56831P-E](#) [LV5684PVD-XH](#) [MCDTSA6-2R](#) [L4953G](#) [L7815ACV-DG](#) [L9524C](#) [PQ3DZ53U](#) [LV56801P-E](#) [TCR3DF13,LM\(CT](#)  
[TCR3DF39,LM\(CT](#) [TLE42794G](#) [L78L05CZ/1SX](#) [L78LR05DL-MA-E](#) [L78MR05-E](#) [033150D](#) [033151B](#) [090756R](#) [636416C](#) [NCV78M15BDTG](#)  
[702482B](#) [714954EB](#) [TLE42794GM](#) [TLE42994GM](#) [ZMR500QFTA](#) [BA033LBSG2-TR](#) [NCV78M05ABDTRKG](#) [NCV78M08BDTRKG](#)  
[NCP7808TG](#) [NCV571SN12T1G](#) [LV5680P-E](#) [CAJ24C256YI-GT3](#) [L78M15CV-DG](#) [L9474N](#) [LD39115J15R](#) [TLS202B1MBV33HTSA1](#) [L79M05T-](#)  
[E](#) [NCP571SN09T1G](#) [MAX15006AASA/V+](#) [MIC5283-5.0YML-T5](#) [L4969URTR-E](#) [L5300GJTR](#) [TLS202A1MBVHTSA1](#) [L78LR05D-MA-E](#)  
[NCV7808BDTRKG](#) [L9466N](#) [NCP7805ETG](#) [SC7812CTG](#) [NCV7809BTG](#) [NCV571SN09T1G](#) [NCV317MBTG](#)