

Dual/Quad Precision Zero-Drift Operational Amplifiers With Internal Capacitors

FEATURES

- Dual/Quad Low Cost Precision Op Amp
- No External Components Required
- Maximum Offset Voltage: 5 μ V
- Maximum Offset Voltage Drift: 0.05 μ V/ $^{\circ}$ C
- Low Noise 1.5 μ V_{P-P} (0.1Hz to 10Hz)
- Minimum Voltage Gain: 120dB
- Minimum PSRR: 120dB
- Minimum CMRR: 114dB
- Low Supply Current: 1mA/Op Amp
- Single Supply Operation: 4.75V to 16V
- Input Common Mode Range Includes Ground
- Output Swings to Ground
- Typical Overload Recovery Time: 3ms
- Pin Compatible with Industry Standard Dual and Quad Op Amps

APPLICATIONS

- Thermocouple Amplifiers
- Electronic Scales
- Medical Instrumentation
- Strain Gauge Amplifiers
- High Resolution Data Acquisition
- DC Accurate R C Active Filters

 LTC and LT are registered trademarks of Linear Technology Corporation.

DESCRIPTION

The LTC[®]1051/LTC1053 are high performance, low cost dual/quad zero-drift operational amplifiers. The unique achievement of the LTC1051/LTC1053 is that they integrate on chip the sample-and-hold capacitors usually required externally by other chopper amplifiers. Further, the LTC1051/LTC1053 offer better combined overall DC and AC performance than is available from other chopper stabilized amplifiers with or without internal sample/hold capacitors.

The LTC1051/LTC1053 have an offset voltage of 0.5 μ V, drift of 0.01 μ V/ $^{\circ}$ C, DC to 10Hz, input noise voltage typically 1.5 μ V_{P-P} and typical voltage gain of 140dB. The slew rate of 4V/ μ s and gain bandwidth product of 2.5MHz are achieved with only 1mA of supply current per op amp.

Overload recover times from positive and negative saturation conditions are 1.5ms and 3ms respectively, about a 100 or more times improvement over chopper amplifiers using external capacitors.

The LTC1051 is available in an 8-lead standard plastic dual-in-line package as well as a 16-pin SW package. The LTC1053 is available in a standard 14-pin plastic package and an 18-pin SO. The LTC1051/LTC1053 are plug in replacements for most standard dual/quad op amps with improved performance.

TYPICAL APPLICATION

High Performance Low Cost Instrumentation Amplifier

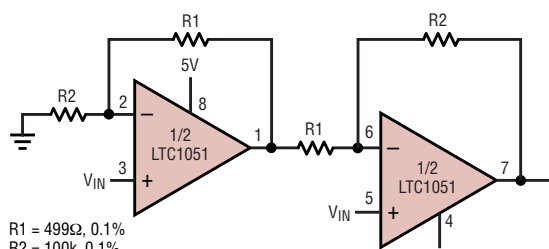

R1 = 499 Ω , 0.1%
 R2 = 100k, 0.1%
 GAIN = 201
 MEASURED CMRR ~ 120dB AT DC
 MEASURED INPUT V_{OS} 3 μ V
 MEASURED INPUT NOISE 2 μ V_{P-P} (DC - 10Hz)

1051/53 TA01a

LTC1051 Noise Spectrum

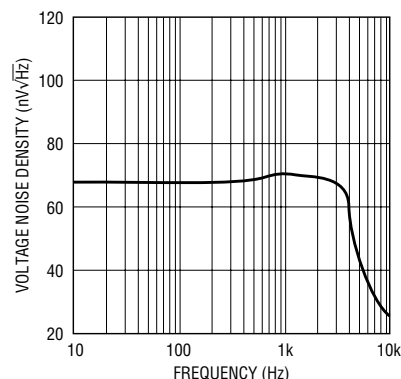

1051/53 TA01b

10513fa

LTC1051/LTC1053

ABSOLUTE MAXIMUM RATINGS (Note 1)

Total Supply Voltage (V^+ to V^-) 16.5V
 Input Voltage ($V^+ + 0.3V$) to ($V^- - 0.3V$)
 Output Short-Circuit Duration Indefinite

Operating Temperature Range

LTC1051M, LTC1051AM (OBSOLETE) .. -55°C to 125°C

LTC1051C/LTC1053C -40°C to 85°C

Storage Temperature Range -65°C to 150°C

Lead Temperature (Soldering, 10 sec) 300°C

PACKAGE/ORDER INFORMATION

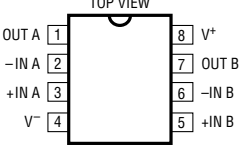
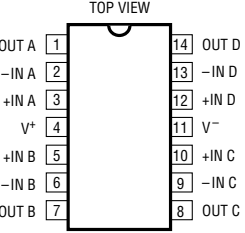
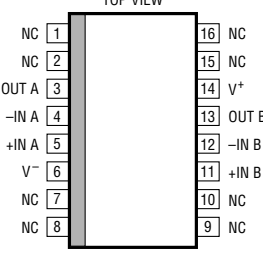
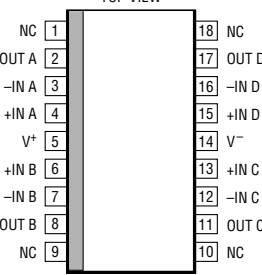
 <p>N8 PACKAGE 8-LEAD PDIP $T_{JMAX} = 150^{\circ}\text{C}$, $\theta_{JA} = 110^{\circ}\text{C/W}$</p> <p>J8 PACKAGE 8-LEAD CERDIP</p> <p>OBSOLETE PACKAGE Consider the N8 Package as an Alternate Source</p>	<p>ORDER PART NUMBER</p> <p>LTC1051CN8 LTC1051MJ8 LTC1051CJ8 LTC1051AMJ8 LTC1051ACJ8</p>	 <p>N PACKAGE 14-LEAD PDIP $T_{JMAX} = 150^{\circ}\text{C}$, $\theta_{JA} = 65^{\circ}\text{C/W}$</p>	<p>ORDER PART NUMBER</p> <p>LTC1053CN</p>
 <p>SW PACKAGE 16-LEAD PLASTIC SO $T_{JMAX} = 150^{\circ}\text{C}$, $\theta_{JA} = 90^{\circ}\text{C/W}$</p>	<p>ORDER PART NUMBER</p> <p>LTC1051CSW</p>	 <p>SW PACKAGE 18-LEAD PLASTIC SO $T_{JMAX} = 150^{\circ}\text{C}$, $\theta_{JA} = 85^{\circ}\text{C/W}$</p>	<p>ORDER PART NUMBER</p> <p>LTC1053CSW</p>

Consult LTC Marketing for parts specified with wider operating temperature ranges.

ELECTRICAL CHARACTERISTICS

The ● denotes the specifications which apply over the full operating temperature range, otherwise specifications are at $T_A = 25^{\circ}\text{C}$. $V_S = \pm 5V$ unless otherwise noted.

PARAMETER	CONDITIONS	LTC1051/LTC1053			LTC1051A			UNITS
		MIN	TYP	MAX	MIN	TYP	MAX	
Input Offset Voltage			± 0.5	± 5		± 0.5	± 5	μV
Average Input Offset Drift			± 0.0	± 0.05		± 0.0	± 0.05	$\mu\text{V}/^{\circ}\text{C}$
Long Term Offset Drift			50			50		$\text{nV}/\sqrt{\text{Mo}}$
Input Bias Current	LTC1051C/LTC1053C		± 15	± 65 ± 135		± 15	± 50 ± 100	μA μA
Input Offset Current	(All Grades)		± 30	± 125 ± 175		± 30	± 100 ± 150	μA μA
Input Noise Voltage (Note 2)	$R_S = 100\Omega$, DC to 10Hz $R_S = 100\Omega$, DC to 1Hz		1.5 0.4			1.5 0.4	2	$\mu\text{V}_{\text{p-p}}$ $\mu\text{V}_{\text{p-p}}$

10513fa

ELECTRICAL CHARACTERISTICS The ● denotes the specifications which apply over the full operating temperature range, otherwise specifications are at $T_A = 25^\circ\text{C}$. $V_S = \pm 5\text{V}$ unless otherwise noted.

PARAMETER	CONDITIONS	LTC1051/LTC1053			LTC1051A			UNITS
		MIN	TYP	MAX	MIN	TYP	MAX	
Input Noise Current	$f = 10\text{Hz}$		2.2		2.2		$\text{fA}/\sqrt{\text{Hz}}$	
Common Mode Rejection Ratio, CMRR	$V_{\text{CM}} = V^-$ to 2.7V	●	106 100	130	114 110	130	dB dB	
Differential CMRR LTC1051, LTC1053 (Note 3)	$V_{\text{CM}} = V^-$ to 2.7V		112		112		dB	
Power Supply Rejection Ratio	$V_S = \pm 2.375\text{V}$ to $\pm 8\text{V}$	●	116	140	120	140	dB	
Large Signal Voltage Gain	$R_L = 10\text{k}$, $V_{\text{OUT}} = \pm 4\text{V}$	●	116	160	120	160	dB	
Maximum Output Voltage Swing	$R_L = 10\text{k}$ $R_L = 100\text{k}$	●	± 4.5 ± 4.5	± 4.85 ± 4.95	± 4.7	± 4.85 ± 4.95	V V	
Slew Rate	$R_L = 10\text{k}$, $C_L = 50\text{pF}$		4		4		$\text{V}/\mu\text{s}$	
Gain Bandwidth Product			2.5		2.5		MHz	
Supply Current/Op Amp	No Load	●	1	2 2.5	1	2 2.5	mA mA	
Internal Sampling Frequency			3.3		3.3		kHz	

The ● denotes the specifications which apply over the full operating temperature range, otherwise specifications are at $T_A = 25^\circ\text{C}$. $V_S = \pm 5\text{V}$ unless otherwise noted. $V_S = 5\text{V}$, GND unless otherwise noted.

PARAMETER	CONDITIONS	LTC1051A/LTC1051/LTC1053			UNITS
		MIN	TYP	MAX	
Input Offset Voltage			± 0.5	± 5	μV
Input Offset Drift			± 0.01	± 0.05	$\mu\text{V}/^\circ\text{C}$
Input Bias Current			± 10	± 50	pA
Input Offset Current			± 20	± 80	pA
Input Noise Voltage	DC to 10Hz		1.8		$\mu\text{V}_{\text{p-p}}$
Supply Current/Op Amp	No Load	●		1.5	mA

Note 1: Absolute Maximum Ratings are those values beyond which the life of a device may be impaired.

Note 2: For guaranteed noise specification contact LTC Marketing.

Note 3: Differential CMRR for the LTC1053 is measured between amplifiers A and D, and amplifiers B and C.

TYPICAL PERFORMANCE CHARACTERISTICS

Common Mode Input Range vs Supply Voltage

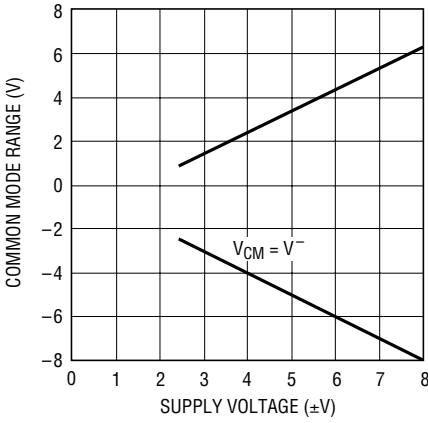

1051/53 G01

Sampling Frequency vs Supply Voltage

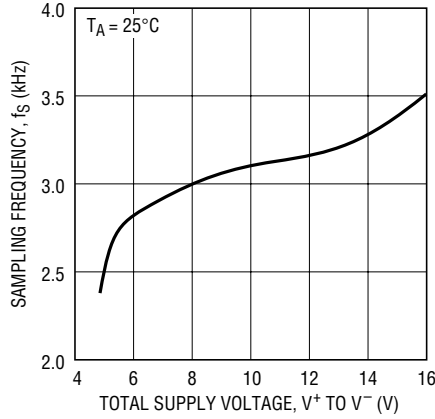

1051/53 G02

Sampling Frequency vs Temperature

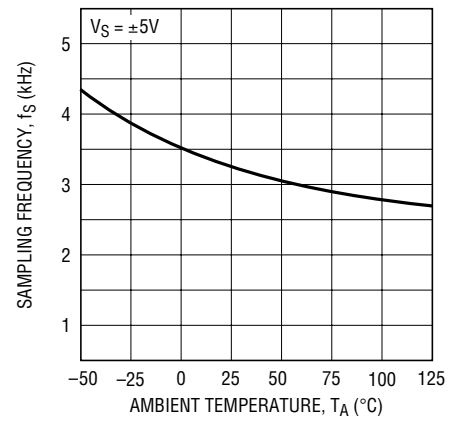

1051/53 G03

Supply Current vs Supply Voltage Per Op Amp

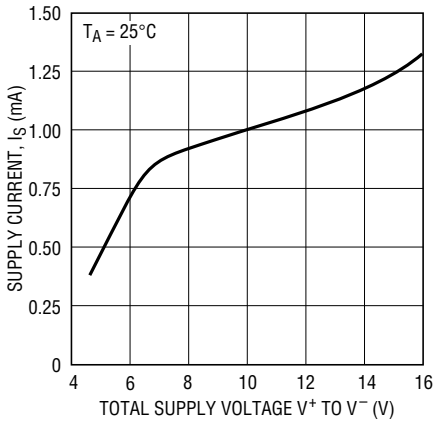

1051/53 G04

Supply Current vs Temperature Per Op Amp

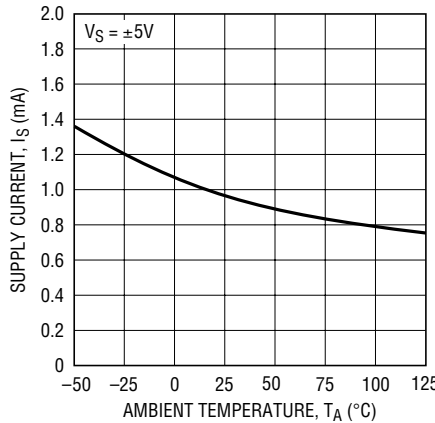

1051/53 G05

Gain/Phase vs Frequency

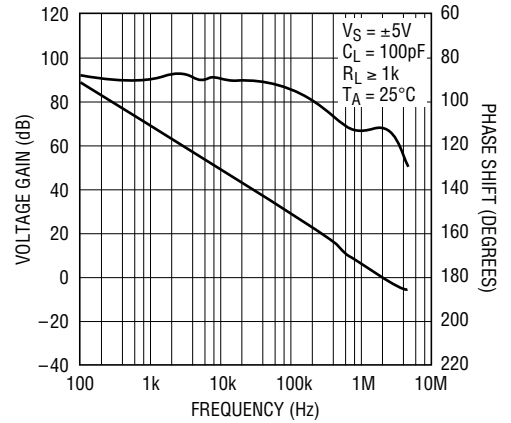

1051/53 G06

Output Short-Circuit Current vs Supply Voltage

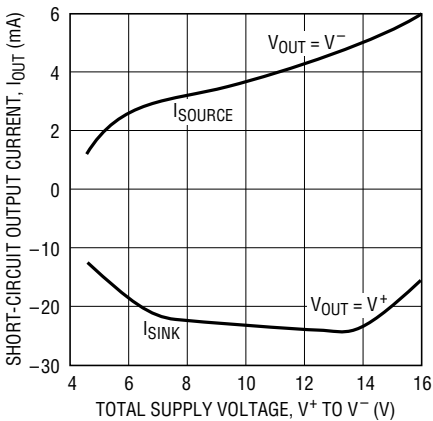

1051/53 G07

CMRR vs Frequency

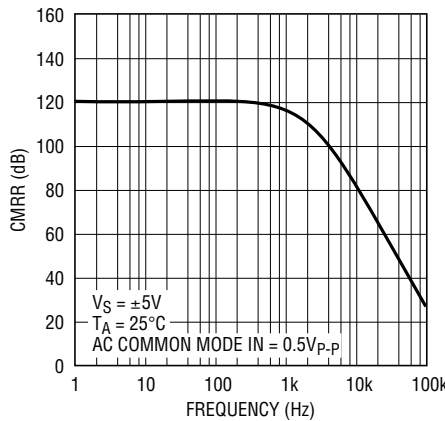

1051/53 G08

Gain/Phase vs Frequency

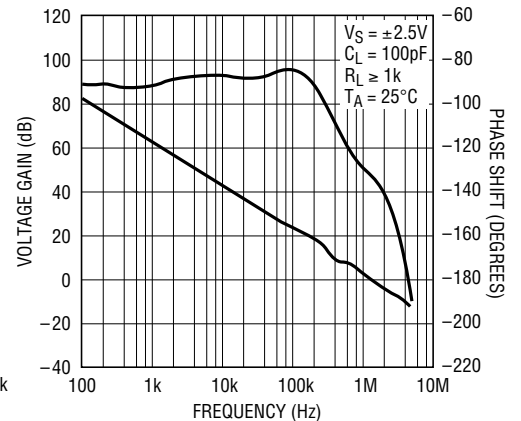

1051/53 G09

TYPICAL PERFORMANCE CHARACTERISTICS

Overload Recovery

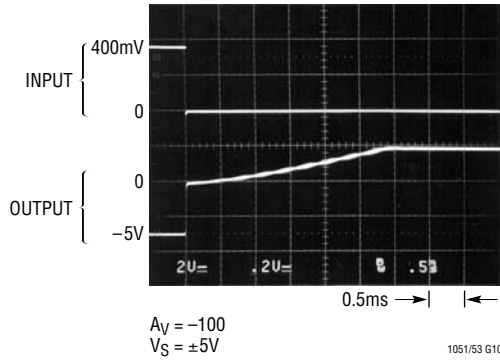

Small Signal Transient Response

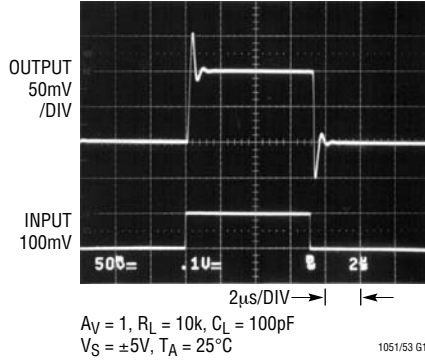

Large Signal Transient Response

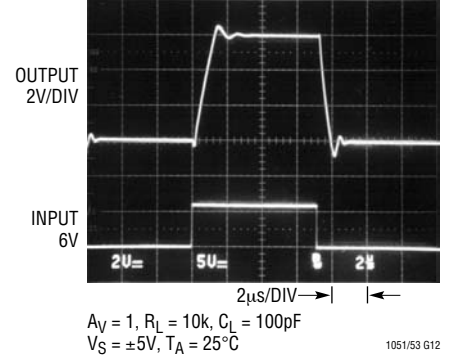

LTC1051/LTC1053 DC to 10Hz Noise

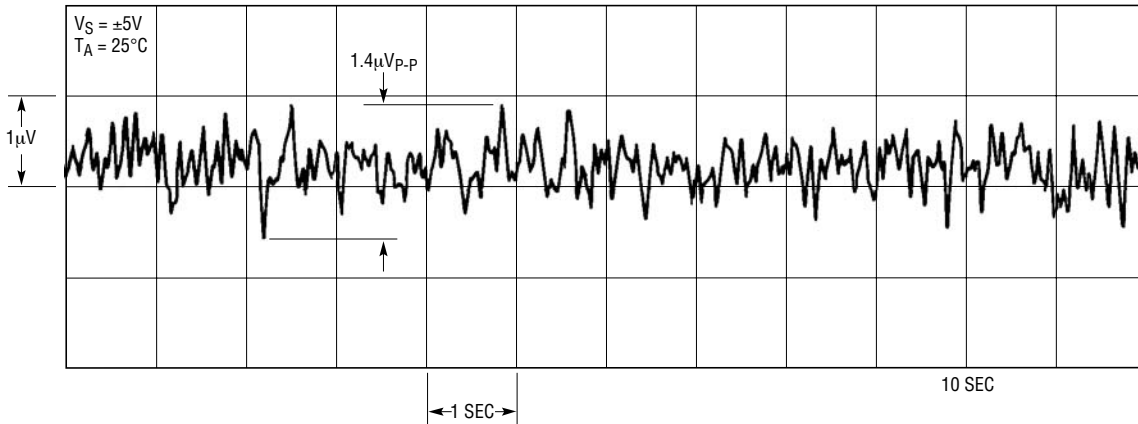

TEST CIRCUITS

Electrical Characteristics Test Circuit

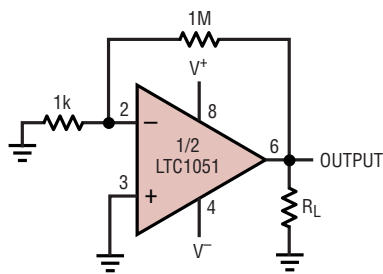

DC 10Hz Noise Test Circuit

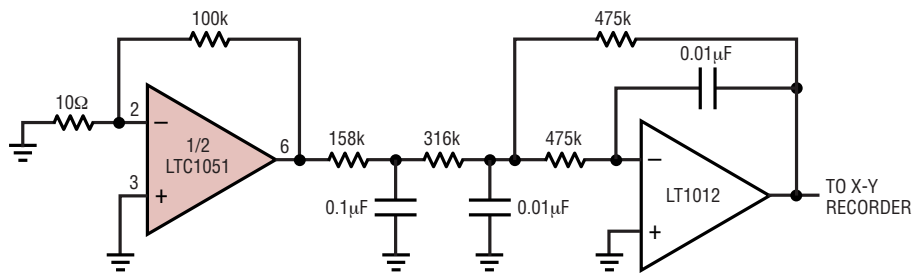

APPLICATIONS INFORMATION

ACHIEVING PICOAMPERE/MICROVOLT PERFORMANCE

Picoamperes

In order to realize the picoampere level of accuracy of the LTC1051/LTC1053, proper care must be exercised. Leakage currents in circuitry external to the amplifier can significantly degrade performance. High quality insulation should be used (e.g., Teflon, Kel-F); cleaning of all insulating surfaces to remove fluxes and other residues will probably be necessary—particularly for high temperature performance. Surface coating may be necessary to provide a moisture barrier in high humidity environments.

Board leakage can be minimized by encircling the input connections with a guard ring operated at a potential close to that of the inputs: in inverting configurations, the guard ring should be tied to ground; in noninverting connections, to the inverting input. Guarding both sides of the printed circuit board is required. Bulk leakage reduction depends on the guard ring width.

Microvolts

Thermocouple effects must be considered if the LTC1051/LTC1053's ultra low drift op amps are to be fully utilized. Any connection of dissimilar metals forms a thermoelectric junction producing an electric potential which varies with temperature (Seebeck effect.) As temperature sensors, thermocouples exploit this phenomenon to produce useful information. In low drift amplifier circuits, this effect is a primary source of error.

Connectors, switches, relay contacts, sockets, resistors, solder, and even copper wire are all candidates for thermal EMF generation. Junctions of copper wire from different manufacturers can generate thermal EMFs of $200\text{nV}/^\circ\text{C}$ —4 times the maximum drift specification of the LTC1051/LTC1053. The copper/kovar junction, formed when wire or printed circuit traces contact a package lead, has a thermal EMF of approximately $35\mu\text{V}/^\circ\text{C}$ —700 times the maximum drift specification of the LTC1051/LTC1053.

Minimizing thermal EMF-induced errors is possible if judicious attention is given to circuit board layout and component selection. It is good practice to minimize the number of junctions in the amplifier's input signal path.

Avoid connectors, sockets, switches and relays where possible. In instances where this is not possible, attempt to balance the number and type of junctions so that differential cancellation occurs. Doing this may involve deliberately introducing junctions to offset unavoidable junctions.

When connectors, switches, relays and/or sockets are necessary, they should be selected for low thermal EMF activity. The same techniques of thermally balancing and coupling the matching junctions are effective in reducing the thermal EMF errors of these components.

Resistors are another source of thermal EMF errors. Table 1 shows the thermal EMF generated for different resistors. The temperature gradient across the resistor is important, not the ambient temperature. There are two junctions formed at each end of the resistor and if these junctions are at the same temperature, their thermal EMFs will cancel each other. The thermal EMF numbers are approximate and vary with resistor value. High values give higher thermal EMF.

Table 1. Resistor Thermal EMF

RESISTOR TYPE	THERMAL EMF/ $^\circ\text{C}$ GRADIENT
Tin Oxide	$\sim\text{mV}/^\circ\text{C}$
Carbon Composition	$\sim 450\mu\text{V}/^\circ\text{C}$
Metal Film	$\sim 20\mu\text{V}/^\circ\text{C}$
Wire Wound Evenohm Manganin	$\sim 2\mu\text{V}/^\circ\text{C}$ $\sim 2\mu\text{V}/^\circ\text{C}$

Input Bias Current, Clock Feedthrough

At ambient temperatures below 60°C , the input bias current of the LTC1051/LTC1053 op amps' is dominated by the small amount of charge injection occurring during the sampling and holding of the op amps' input offset voltage. The average value of the resulting current pulses is 10pA to 15pA with sign convention shown in Figure 1.

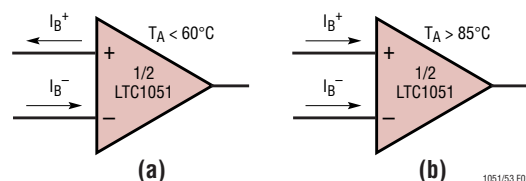

Figure 1. LTC1051 Bias Current

1051/53 F01

APPLICATIONS INFORMATION

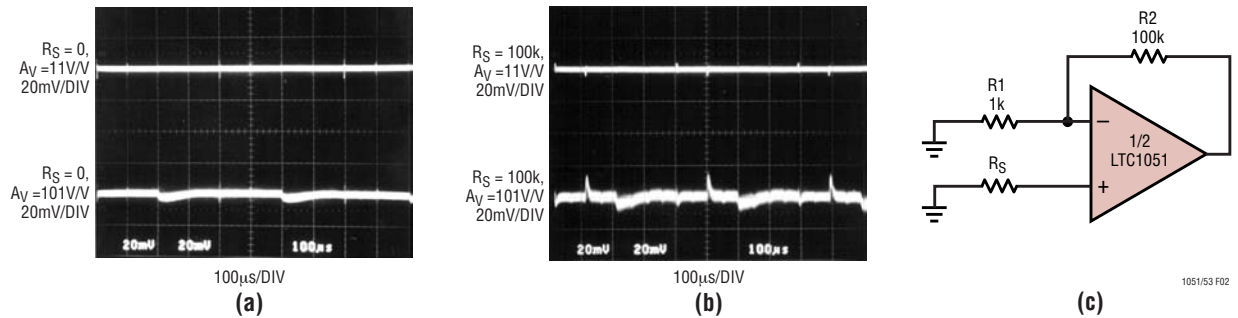

Figure 2. Clock Feedthrough

As the ambient temperature rises, the leakage current of the input protection devices increases, while the charge injection component of the bias current, for all practical purposes, stays constant. At elevated temperatures (above 85°C) the leakage current dominates and the bias current of both inputs assumes the same sign.

The charge injection at the op amp input pins will cause small output spikes. This phenomenon is often referred to as “clock feedthrough” and can be easily observed when the closed-loop gain exceeds $10V/V$ (Figure 2). The magnitude of the clock feedthrough is temperature independent but it increases when the closed-loop gain goes up, when the source resistance increases and when the gain setting resistors increase (Figure 2a, 2b). It is important to note that the output small spikes are centered at $0V$ level and do not add to the output offset error budget. For instance, with $R_S = 1M\Omega$, the typical output offset voltage of Figure 2c is:

$$V_{OS(OUT)} \approx 10^8 \cdot I_B^+ + 101V_{OS(IN)}$$

A $10pA$ bias current will yield an output of $1mV \pm 100\mu V$. The output clock feedthrough can be attenuated by lowering the value of the gain setting resistors, i.e. $R_2 = 10k$, $R_1 = 100\Omega$, instead of $100k$ and $1k$ (Figure 2).

Clock feedthrough can also be attenuated by adding a capacitor across the feedback resistor to limit the circuit bandwidth below the internal sampling frequency (Figure 3).

Input Capacitance

The input capacitance of the LTC1051/LTC1053 op amps is approximately $12pF$. When the LTC1051/LTC1053 op amps are used with feedback factors approaching unity,

the feedback resistor value should not exceed $7k$ for industrial temperature range and $5k$ for military temperature range. If a higher feedback resistor value is required, a feedback capacitor of $20pF$ should be placed across the feedback resistor. Note that the most common circuits with feedback factors approaching unity are unity gain followers and instrumentation amplifier front ends. (See Figure 4.)

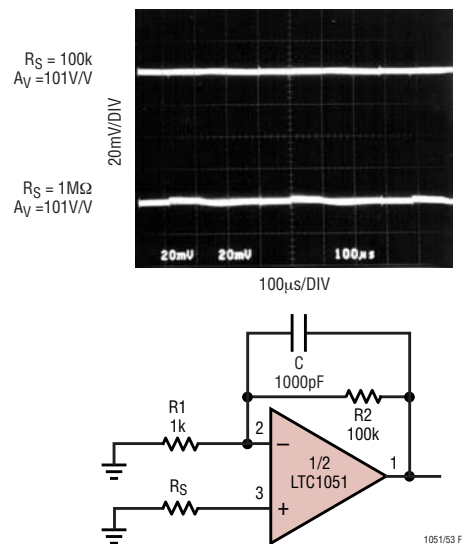

Figure 3. Adding a Feedback Capacitor to Eliminate Clock Feedthrough

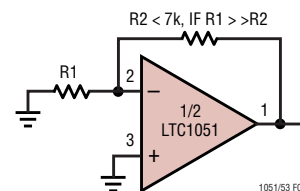

Figure 4. Operating the LTC1051 with Feedback Factors Approaching Unity

APPLICATIONS INFORMATION

LTC1051/LTC1053 as AC Amplifiers

Although initially chopper stabilized op amps were designed to minimize DC offsets and offset drifts, the LTC1051/LTC1053 family, on top of its outstanding DC characteristics, presents efficient AC performance. For instance, at single 5V supply, each op amp typically consumes 0.5mA and still provides 1.8MHz gain bandwidth product and 3V/ μ s slew rate. This, combined with almost distortionless swing to the supply rails (Figure 8), makes the LTC1051/LTC1053 op amps nearly general purpose. To further expand this idea (the “aliasing” phenomenon) which can occur under AC conditions, should be described and properly evaluated.

Aliasing

The LTC1051/LTC1053 are equipped with internal circuitry to minimize aliasing. Aliasing, no matter how small, occurs when the input signal approaches and exceeds the internal sampling rate. Aliasing is caused by the sampled data nature of the chopper op amps. A generalized study of this phenomenon is beyond the scope of a data sheet; however, a set of rules of thumb can answer many questions:

1. Alias signals can be generally defined as output AC signals at a frequency of $nf_{CLK} \pm mf_{IN}$. The nf_{CLK} term is the internal sampling frequency of the chopper stabilized op amps and its harmonics; mf_{IN} is the frequency of the input signal and its harmonics, if any.

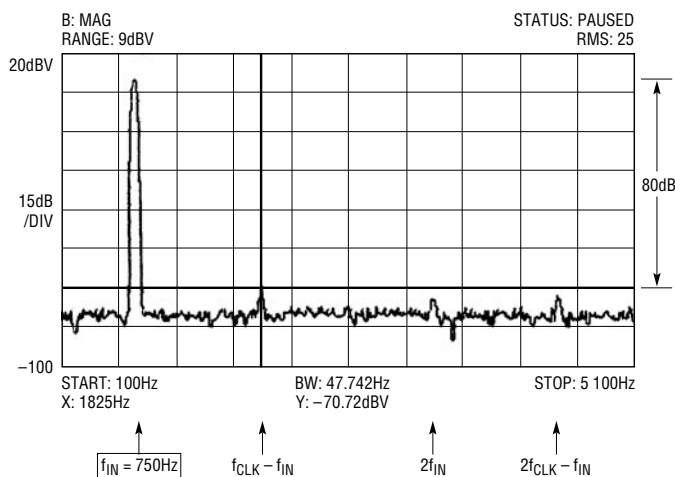

Figure 5a. Output Voltage Spectrum of 1/2 LTC1051 Operating as an Inverting Amplifier with Gain of 10, and Amplifying a 750Hz/800mV, Input AC Signal

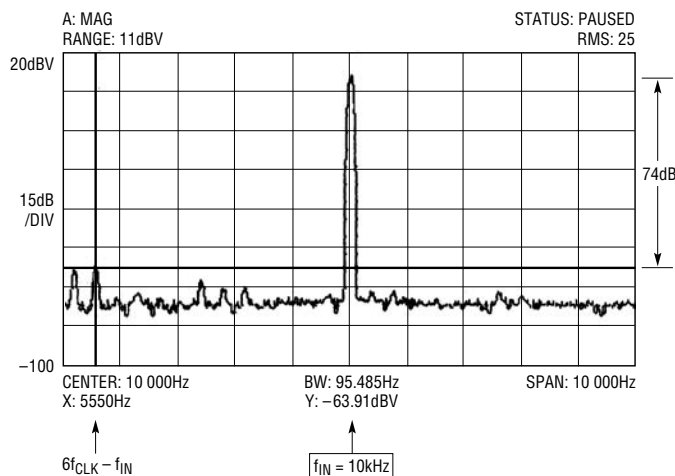
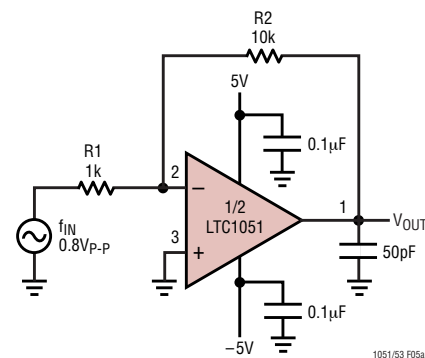

Figure 5b. Same as Figure 5a, but the AC Input Signal is 900mV, 10kHz

APPLICATIONS INFORMATION

2. If we arbitrarily accept that “aliasing” occurs when output alias signals reach an amplitude of 0.01% or more of the output signal, then: the approximate minimum frequency of an AC input signal which will cause aliasing is equal to the internal clock frequency multiplied by the square root of the op amp feedback factor. For instance, with closed-loop gain of -10 , the feedback factor is $1/11$ and if $f_{CLK} = 2.6\text{kHz}$, alias signals can be detected when the frequency of the input signal exceeds 750Hz to 800Hz (Figure 5a).

3. The number of alias signals increases when the input signal frequency increases (Figure 5b).

4. When the frequency, f_{IN} , of the input signal is less than f_{CLOCK} , the alias signal(s) amplitude(s) directly scale with the amplitude of the incoming signal. The output “signal to alias ratio” cannot be increased by just boosting the input signal amplitude. However, when the input AC signal frequency well exceeds the clock frequency, the amplitude of the alias signals does not directly scale with the input amplitude. The “signal to alias ratio” increases when the output swings closely to the rails. (See Figure 5b and Figure 7.) It is important to note that the LTC1051/LTC1053 op amps, under light loads ($R_L \geq 10\text{k}$), swing closely to the supply rails without generating harmonic distortion (Figure 8).

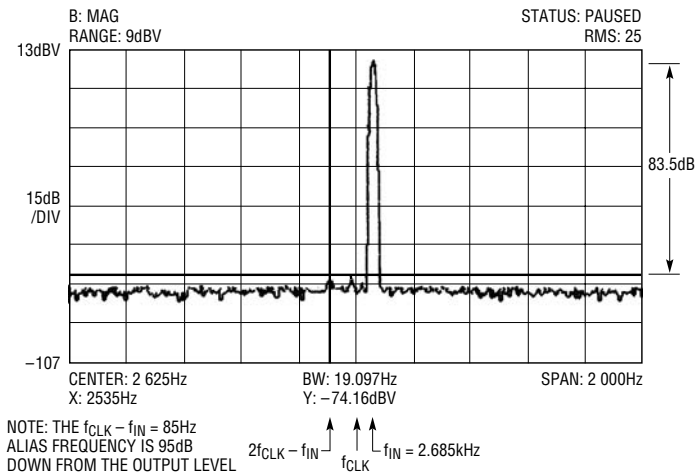

Figure 6a. Output Voltage Spectrum of 1/2 LTC1051 Operating as a Unity-Gain Inverting Amplifier. $V_S = \pm 5\text{V}$, $R_L = 10\text{k}$, $C_L = 50\text{pF}$, $V_{IN} = 8\text{V}_{P-P}$, 2.685kHz

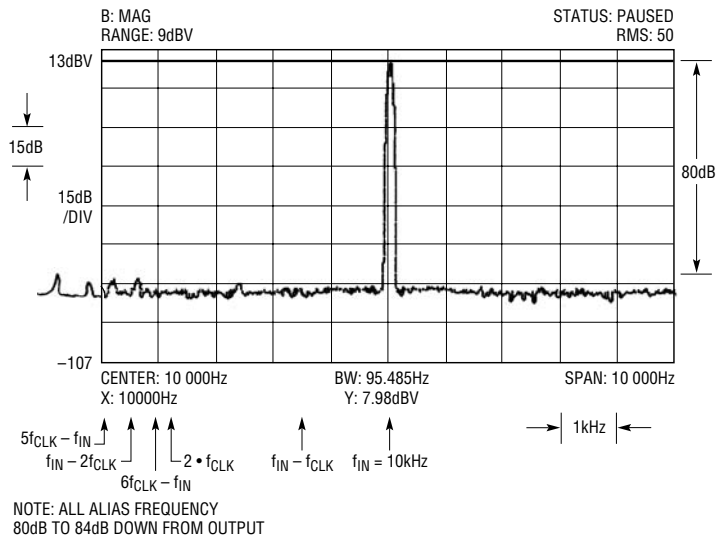
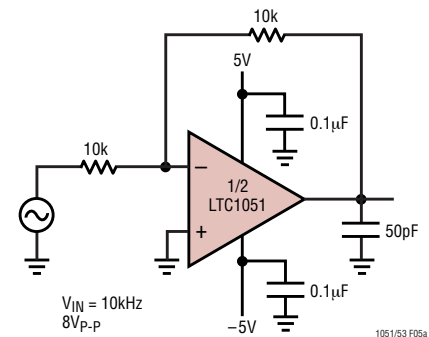

Figure 6b. Output Voltage Spectrum of 1/2 LTC1051 Operating as a Unity-Gain Inverting Amplifier. $V_S = \pm 5\text{V}$, $R_L = 10\text{k}$, $C_L = 50\text{pF}$, $V_{IN} = 8\text{V}_{P-P}$, 10kHz



APPLICATIONS INFORMATION

5. For unity-gain inverting configuration, all the alias frequencies are 80dB to 84dB down from the output signal (Figures 6a, 6b). Combined with excellent THD under wide swing, the LTC1051/LTC1053 op amps make efficient unity gain inverters.

For gain higher than -1 , the “signal to alias” ratio decreases at an approximate rate of -6dB per decade of closed-loop gain (Figure 9).

6. For closed-loop gains of -10 or higher, the “signal to alias” ratio degrades when the value of the feedback gain setting resistor increases beyond 50k. For instance, the

68dB value of Figure 7 decreases to 56dB if a (1k, 100k) resistor set is used to set the gain of -100 .

7. When the LTC1051/LTC1053 are used as noninverting amplifiers, all the previous approximate rules of thumb apply with the following exceptions: when the closed-loop gain is $10(\text{V/V})$ and below, the “signal to alias” ratio is 1dB to 3dB less than the inverting case; when the closed-loop gain is $100(\text{V/V})$, the degradation can be up to 9dB, especially when the input signal is much higher than the clock frequency (i.e. $f_{\text{IN}} = 10\text{kHz}$).

8. The signal/alias ratio performance improves when the op amp has bandlimited loop gain.

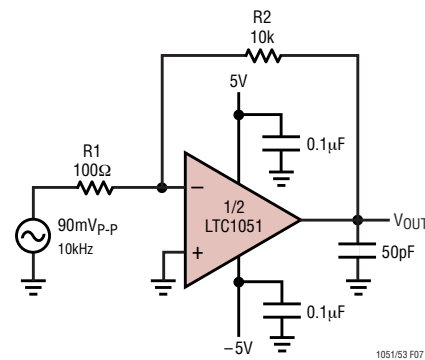
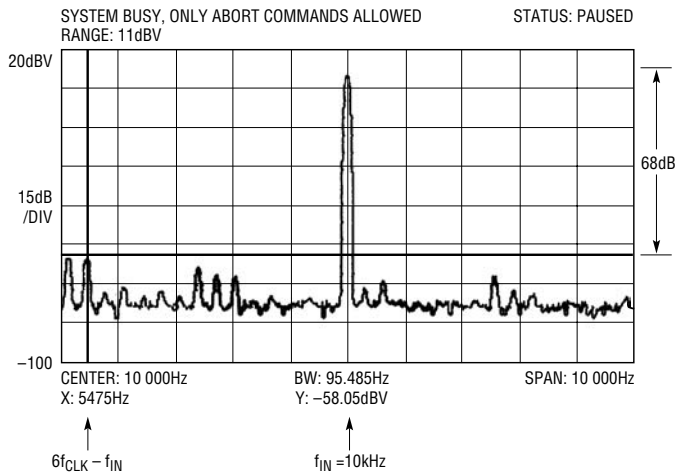

Figure 7. Output Voltage Spectrum of 1/2 LTC1051 Operating as an Inverting Amplifier with a Gain of -100 and Amplifying a $90\text{mV}_{\text{P-P}}$, 10kHz Input Signal. With a $9\text{V}_{\text{P-P}}$ Output Swing the Measured 2nd Harmonic (20kHz) was 75 Down from the 10kHz Input Signal

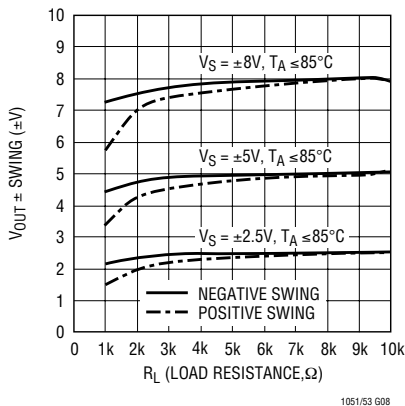

Figure 8. Output Voltage Swing vs Load

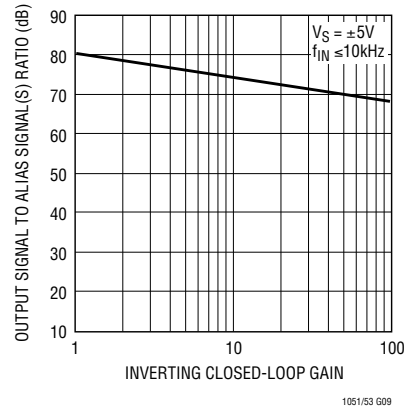
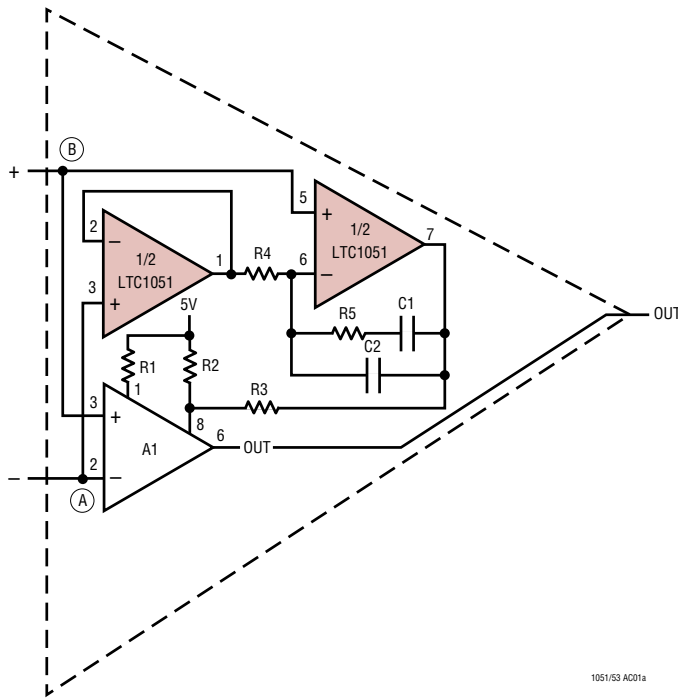

Figure 9. Signal to Alias Ratio vs Closed-Loop Gain

TYPICAL APPLICATIONS

Obtaining Ultralow V_{OS} Drift and Low Noise



The dual chopper op amp buffers the inputs of A1 and corrects its offset voltage and offset voltage drift. With the R, C values shown, the power-up warm up time is typically 20 seconds. The step response of the composite amplifier does not present settling tails. The LT1007 should be used when extremely low noise; V_{OS} and V_{OS} drift are sought when the input source resistance is low—for instance a 350Ω strain gauge bridge. The LT1012 or equivalent should be used when low bias current (100pA) is also required in conjunction with DC to 10Hz low noise and low V_{OS} and V_{OS} drift. The measured typical input offset voltages were less than 2μV.

1051/53 AD01a

A1	R1	R2	R3	R4	R5	C1	C2	$e_{OUT}(DC - 1Hz)^{**}$	$e_{OUT}(DC - 10Hz)^{**}$
LT1007	3k	2k	340k	10k	100k	0.01μF	0.001μF	0.1μV _{P-P}	0.15μV _{P-P}
LT1012*	750Ω	57Ω	250k	10k	100k	0.01μF	0.001μF	0.3μV _{P-P}	0.4μV _{P-P}

* Interchange connections (A) and (B).

** Noise measured in a 10 sec window. Peak-to-peak noise was also measured for 10 continuous minutes: With the LT1007 op amp the recorded noise was less than 0.2μV_{P-P} for both DC-1Hz and DC-10Hz.

LTC1051/LT1007 Peak-to-Peak Noise

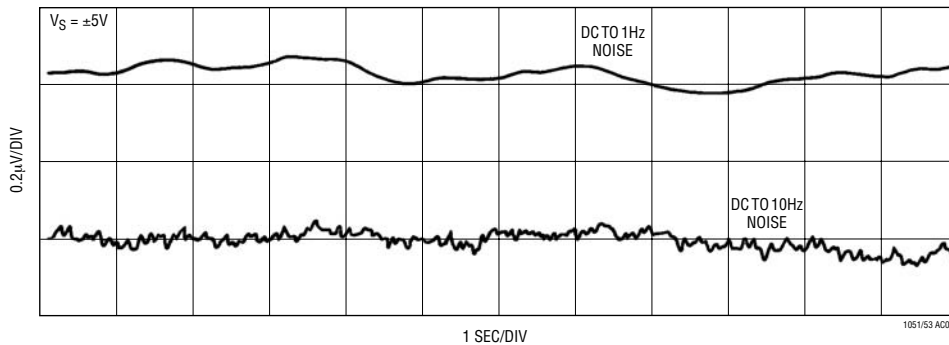

1051/53 AD01b

TYPICAL APPLICATIONS

Paralleling Choppers to Improve Noise

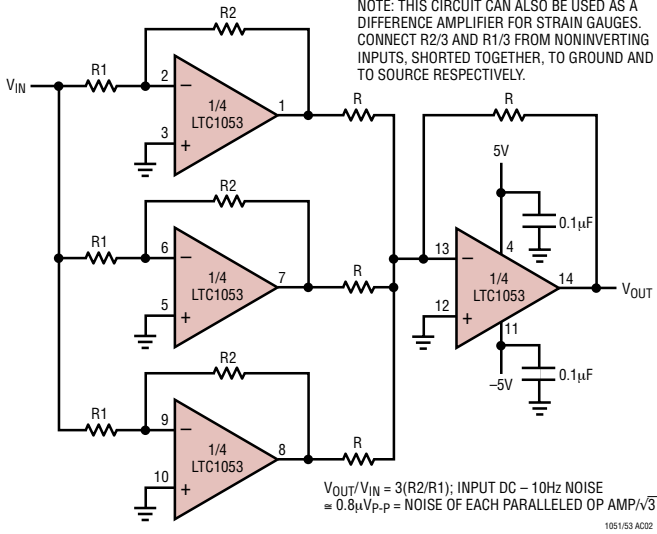

Differential Voltage to Current Converter

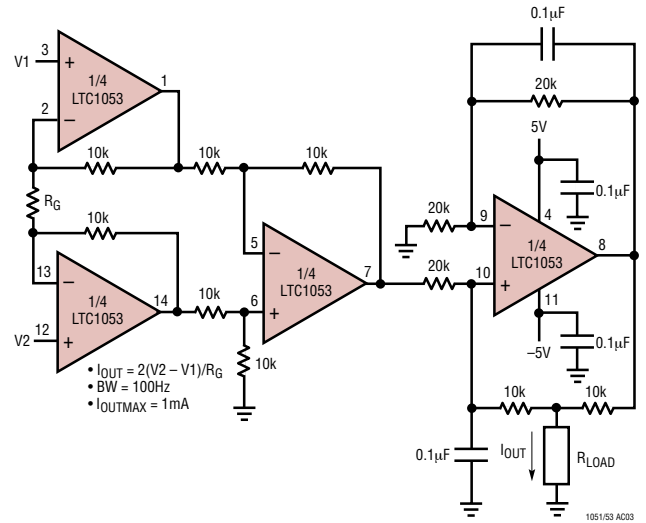

Multiplexed Differential Thermometer

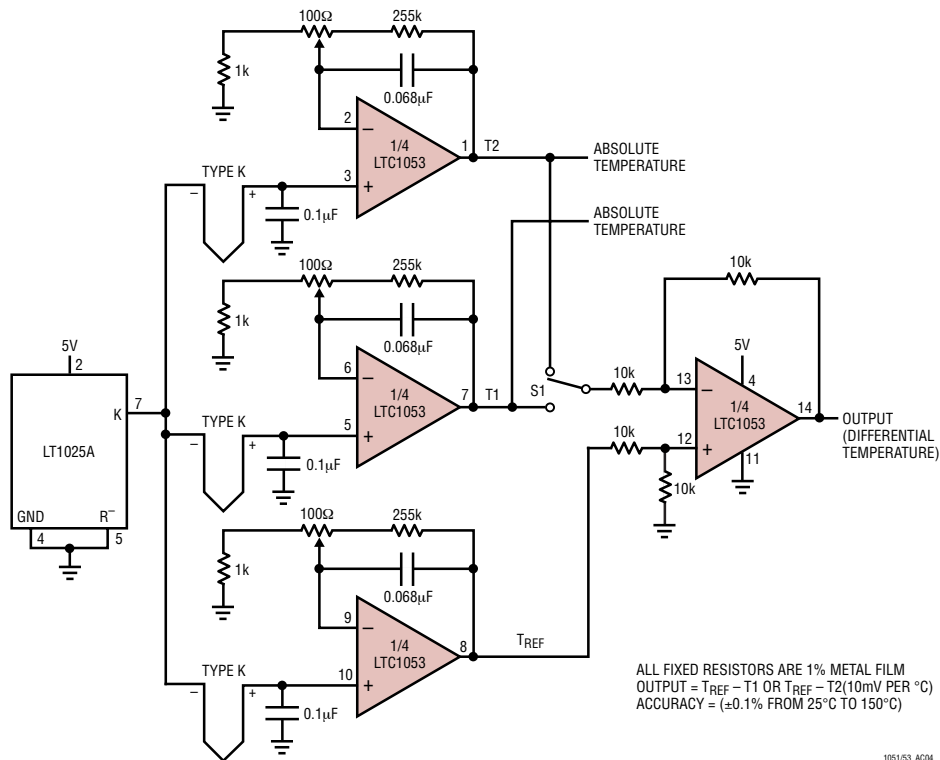

TYPICAL APPLICATIONS

Six Decade Log Amplifier

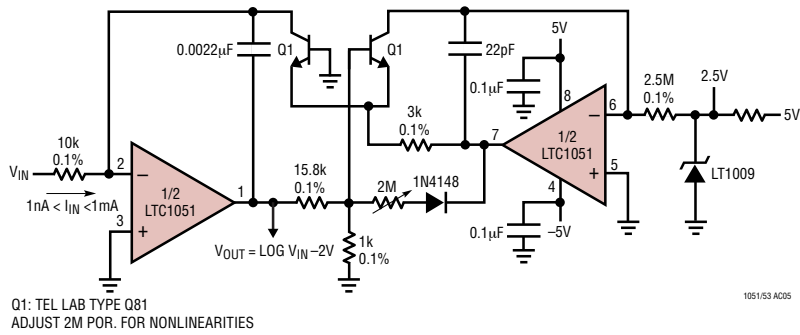

Dual Instrumentation Amplifier

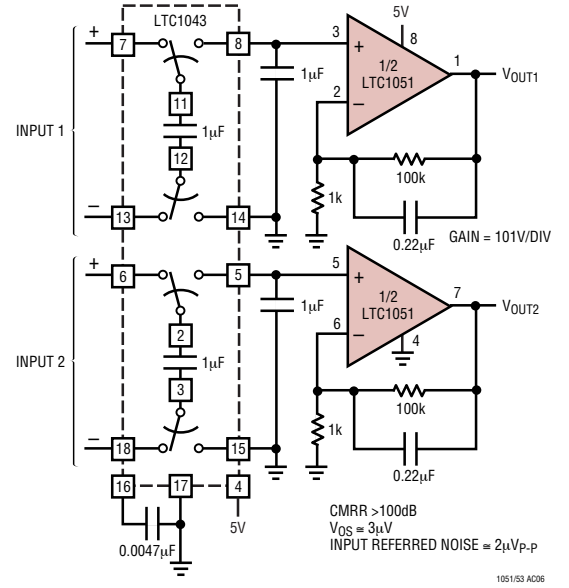

Linearized Platinum Signal Conditioner

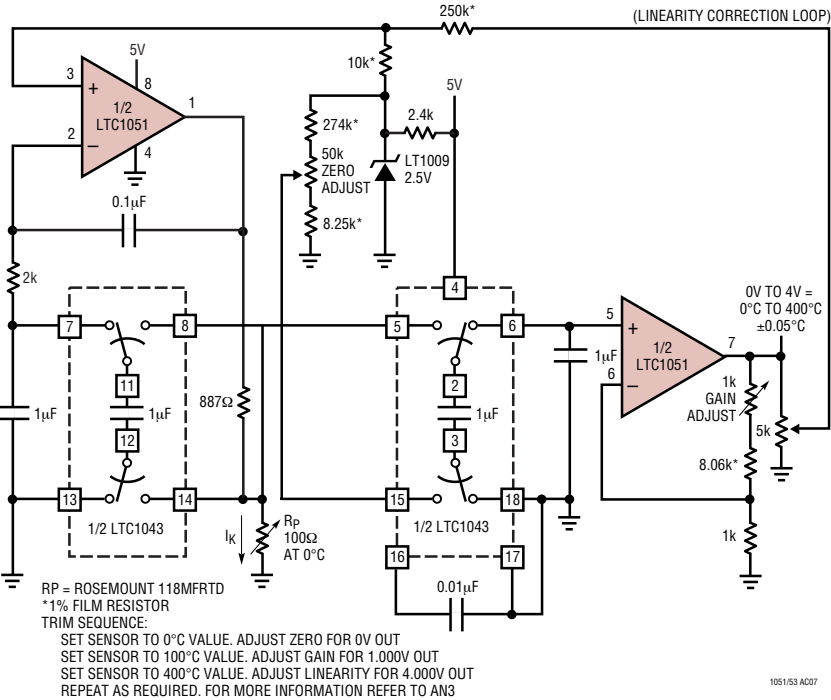

PACKAGE DESCRIPTION

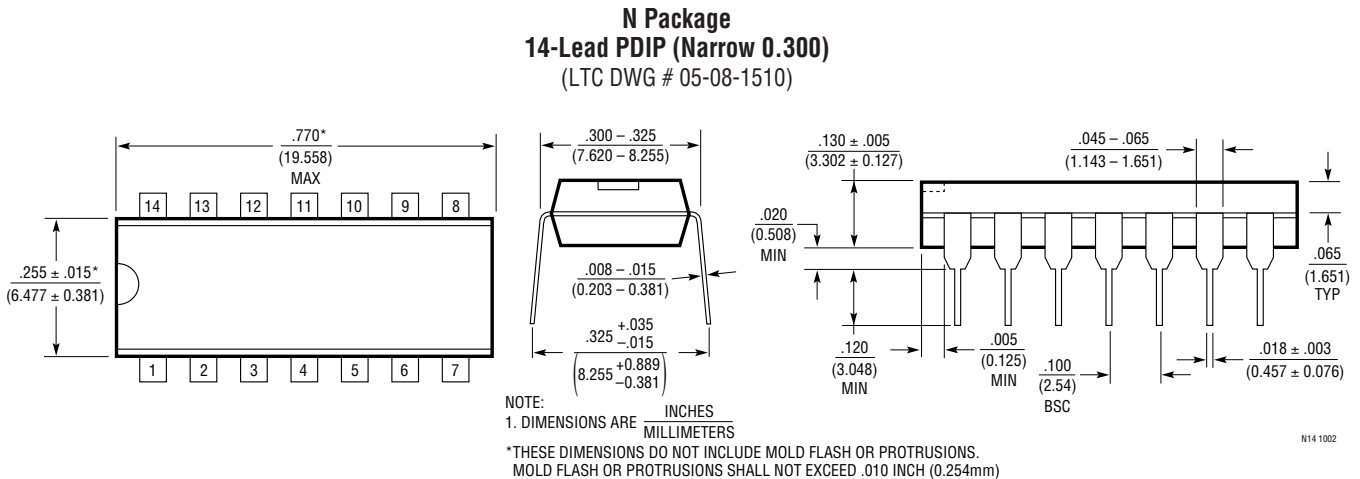
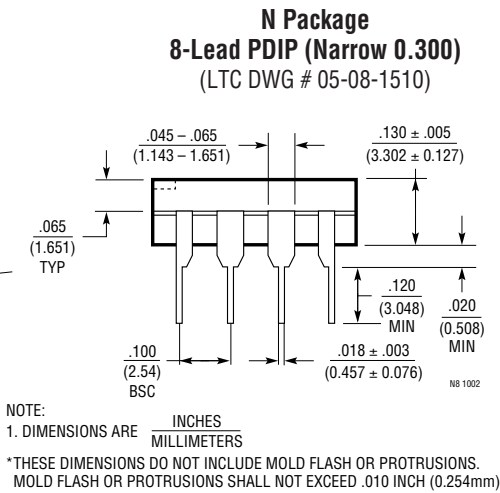
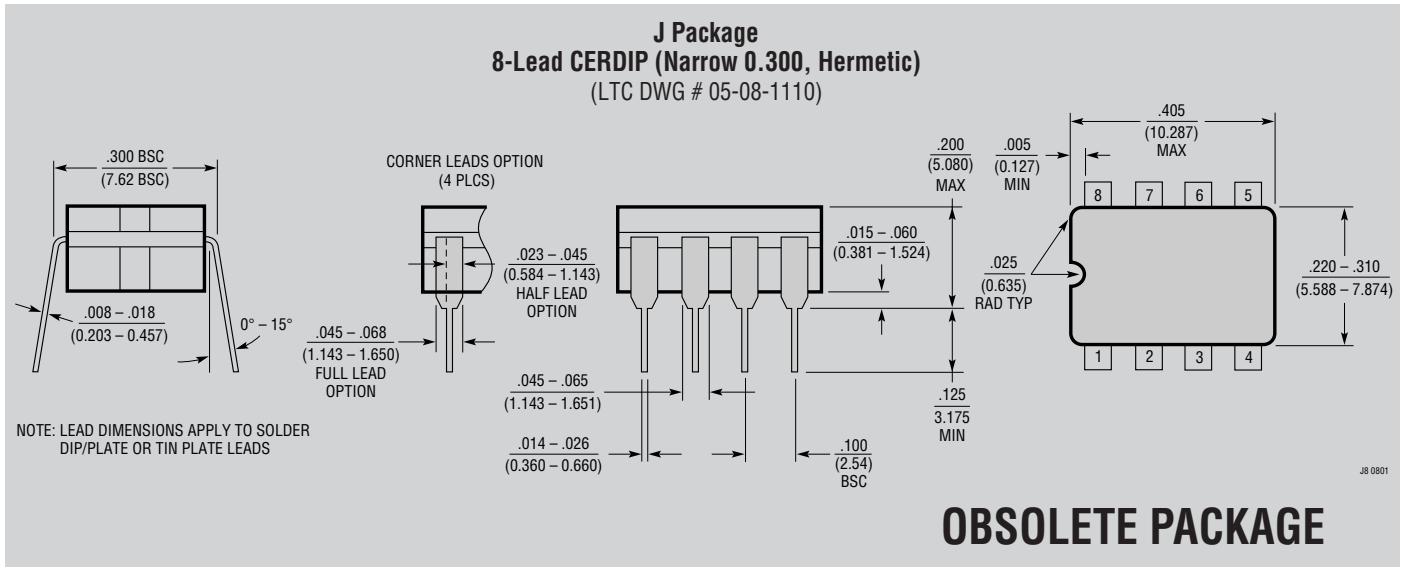

PACKAGE DESCRIPTION

SW Package 16-Lead Plastic Small Outline (Wide 0.300) (LTC DWG # 05-08-1620)

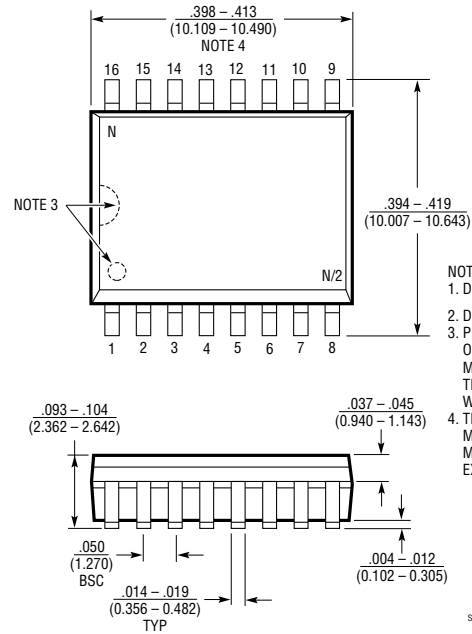
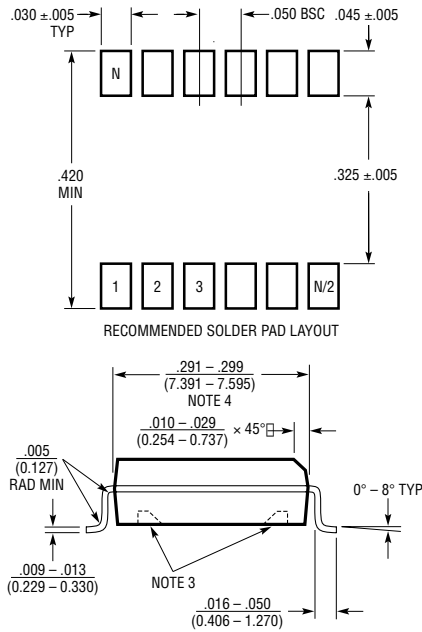

- NOTE:
1. DIMENSIONS IN $\frac{\text{INCHES}}{\text{MILLIMETERS}}$
 2. DRAWING NOT TO SCALE
 3. PIN 1 IDENT, NOTCH ON TOP AND CAVITIES ON THE BOTTOM OF PACKAGES ARE THE MANUFACTURING OPTIONS. THE PART MAY BE SUPPLIED WITH OR WITHOUT ANY OF THE OPTIONS
 4. THESE DIMENSIONS DO NOT INCLUDE MOLD FLASH OR PROTRUSIONS. MOLD FLASH OR PROTRUSIONS SHALL NOT EXCEED .006" (0.15mm)

S16 (WIDE) 0502

SW Package 18-Lead Plastic Small Outline (Wide 0.300) (LTC DWG # 05-08-1620)

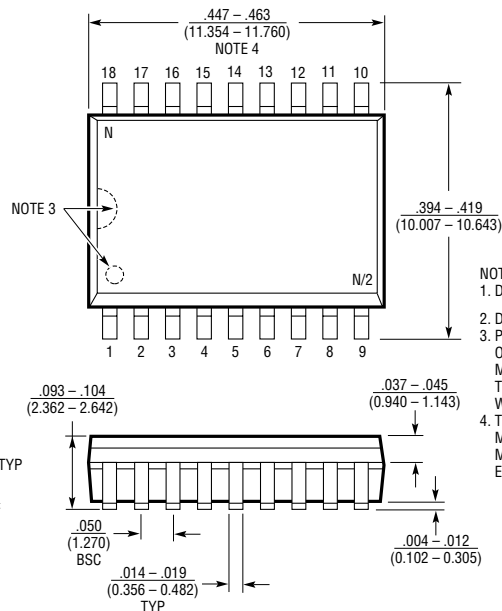
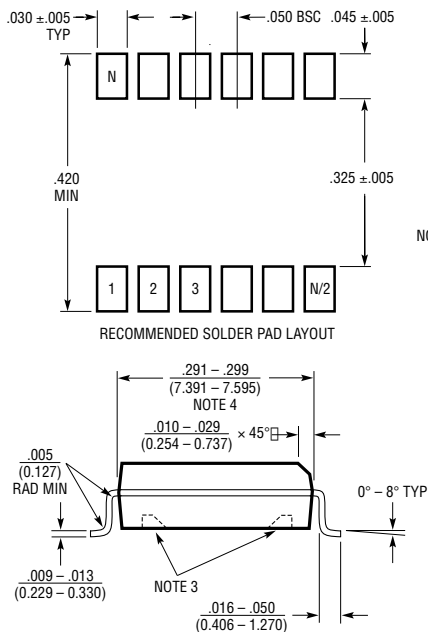

- NOTE:
1. DIMENSIONS IN $\frac{\text{INCHES}}{\text{MILLIMETERS}}$
 2. DRAWING NOT TO SCALE
 3. PIN 1 IDENT, NOTCH ON TOP AND CAVITIES ON THE BOTTOM OF PACKAGES ARE THE MANUFACTURING OPTIONS. THE PART MAY BE SUPPLIED WITH OR WITHOUT ANY OF THE OPTIONS
 4. THESE DIMENSIONS DO NOT INCLUDE MOLD FLASH OR PROTRUSIONS. MOLD FLASH OR PROTRUSIONS SHALL NOT EXCEED .006" (0.15mm)

S18 (WIDE) 0502

LTC1051/LTC1053

TYPICAL APPLICATIONS

DC Accurate, 3rd Order, 100Hz, Butterworth Antialiasing Filter

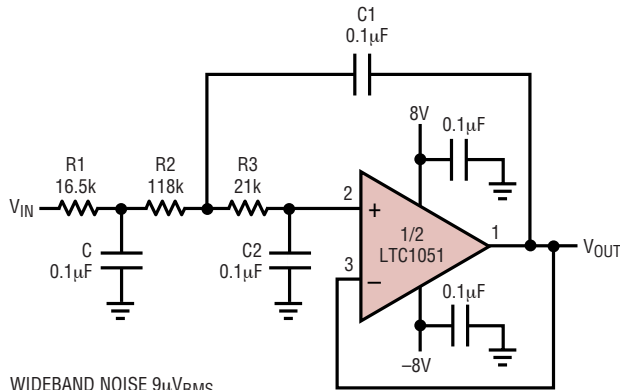

WIDEBAND NOISE $9\mu\text{V}_{\text{RMS}}$
 THD + NOISE $\approx 0.0012\%$, $1\text{V}_{\text{RMS}} < V_{\text{IN}} < 2\text{V}_{\text{RMS}}$, $V_{\text{S}} = \pm 8\text{V}$
 $V_{\text{OS}}(\text{OUT}) < 5\mu\text{V}$

1051/53 AC08

Dynamic Range

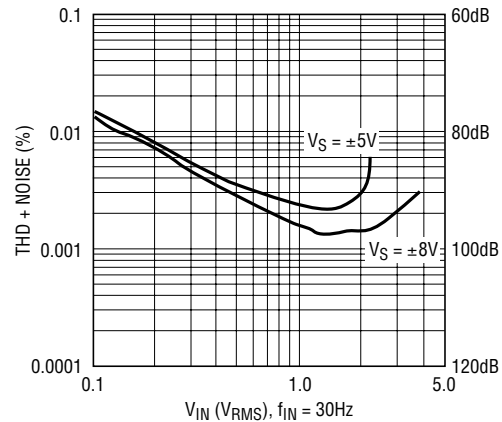

1051/53 AC09

DC Accurate, 18-Bit, 4th Order Antialiasing Bessel (Linear Phase), 100Hz, Lowpass Filter

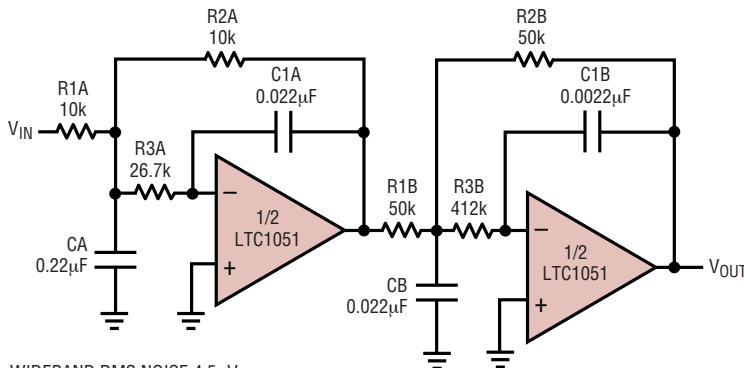

WIDEBAND RMS NOISE $4.5\mu\text{V}_{\text{RMS}}$
 THD + NOISE $\approx 0.0005\%$ ($\approx 106\text{dB}$ DYNAMIC RANGE), $2\text{V}_{\text{RMS}} \leq V_{\text{IN}} \leq 3\text{V}_{\text{RMS}}$
 $V_{\text{OS}} \text{ OUT} < 10\mu\text{V}$

1051/53 AC10

Dynamic Range

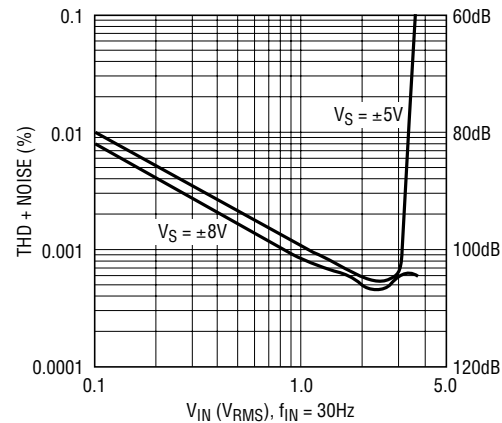

1051/53 AC11

RELATED PARTS

PART NUMBER	DESCRIPTION	COMMENTS
LTC1047	Dual μ Power Zero-Drift Op Amp	$I_{\text{S}} = 80\mu\text{A}/\text{Op Amp}$, 16-Lead SW Package
LTC1049	Low Power Zero-Drift Op Amp	$I_{\text{S}} = 200\mu\text{A}$, SO-8 Package
LTC1050	Precision Zero-Drift Op Amp with Internal Capacitors	$V_{\text{OS}}(\text{Max}) = 5\mu\text{V}$, $V_{\text{SUPPLY}}(\text{Max}) = 16.5\text{V}$
LTC2050/LTC2051/LTC2052	Single/Dual/Quad Zero-Drift Op Amps	SOT-23/MS8/GN16 Packages
LTC2053	Zero-Drift Instrumentation Amp	Resistor Programmable Gain, R-R

10513fa

X-ON Electronics

Largest Supplier of Electrical and Electronic Components

Click to view similar products for [Operational Amplifiers - Op Amps](#) category:

Click to view products by [Analog Devices](#) manufacturer:

Other Similar products are found below :

[OPA2991IDSGR](#) [OPA607IDCKT](#) [007614D](#) [633773R](#) [635798C](#) [635801A](#) [702115D](#) [709228FB](#) [741528D](#) [NCV33072ADR2G](#) [SC2903DR2G](#)
[SC2903VDR2G](#) [LM258AYDT](#) [LM358SNG](#) [430227FB](#) [430228DB](#) [460932C](#) [AZV831KTR-G1](#) [514272R](#) [409256CB](#) [430232AB](#)
[LM2904DR2GH](#) [LM358YDT](#) [508582D](#) [LT1026CN8](#) [LT1678IS8](#) [042225DB](#) [058184EB](#) [070530X](#) [714228XB](#) [714846BB](#) [873836HB](#)
[TS912BIYDT](#) [NCS5651MNTXG](#) [NCS2004MUTAG](#) [NCV33202DMR2G](#) [M38510/13101BPA](#) [NTE925](#) [TL082IYDT](#) [SC2904DR2G](#)
[SC358DR2G](#) [LM2904EDR2G](#) [LM358EDR2G](#) [AZV358MTR-G1](#) [AP4310AUMTR-AG1](#) [HA1630D02MMEL-E](#) [NJM358CG-TE2](#)
[HA1630S01LPEL-E](#) [AD8037SRZ-EP](#) [LM324AWPT](#)