



**Operation Manual for the  
TT-65 Heater Assembly (Assembly With Sensor)  
PACE PART NUMBER 6010-0082-P1  
MANUAL NUMBER 5050-0297 Rev. G**

**IMPORTANT NOTICE** - Two different heater assemblies on your handpiece TT-65. The enclosed heater contains five (5) wires and is installed in the half of the handpiece where the power cord enters the handle. If you have obtained the wrong replacement heater then you must obtain PACE Part Number 6010-0083 before proceeding any further. Follow the procedure listed below to obtain optimum results.

1. Disconnect the TT-65 handpiece from the power receptacle of the system power source.
2. Remove the two (2) Gripper Mounting Screws on the Handle W/Sensor side of the handpiece (side with the Power Cable entering at the rear). Set Gripper (with or without cushions) and screws aside.
3. Separate the two handpiece handles. The wiring of the defective heater is now exposed. The wiring of the heater w/o sensor remains hidden.
4. Remove the two (2) Heater Mounting Screws.
5. Carefully disconnect the five (5) heater leads from the Power Cable leads. Remove the defective heater from the handpiece.
6. Carefully plug the five (5) color-coded leads of the replacement heater into the Power Cable leads as shown. Note that the ground wire (Green colored or Bare) is the only wire that can be observed.
  - a) Plug the Bare (non-insulated) heater lead into the Green Power Cable lead
  - b) Plug the two Blue heater leads (copper colored ends) into the Blue and the Orange Power Cable leads.
  - c) Plug the two Tan sensor leads (silver colored ends) into the Yellow and the Red Power Cable leads.
7. Mount the replacement heater to the handle using the two (2) Heater Mounting Screws removed in step 4.

**NOTE**

The tab of the heater flange must fit into the notch located on the outside edge of the handle.

8. Insure that the heater and Power Cable leads are dressed along the inside edges of the handle and not over the two mounting shoulders in the handle center.
9. Carefully mate the two handpiece halves back together.
10. Install the Gripper and two (2) Gripper Mounting Screws removed in step 2.
11. Check the ends of both heaters to insure proper alignment with each other. If the end of one heater extends beyond the other, loosen the Hinge Screw. Move the handles back and forth to align ends of heaters.

**NOTE**

Placement of the heater ends against a flat work surface with the handpiece held in a vertical position is recommended to ease alignment.

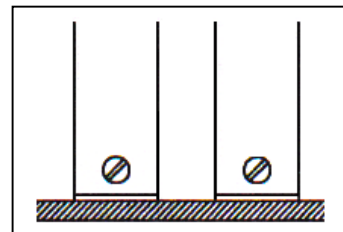

12. Tighten Hinge Screw to secure in position. Recheck the alignment.
13. Connect the handpiece to the system power source.
14. The handpiece is now ready for normal operation.

### NOTE

A small amount of smoke will be emitted for a period of time when the heater is initially powered up.

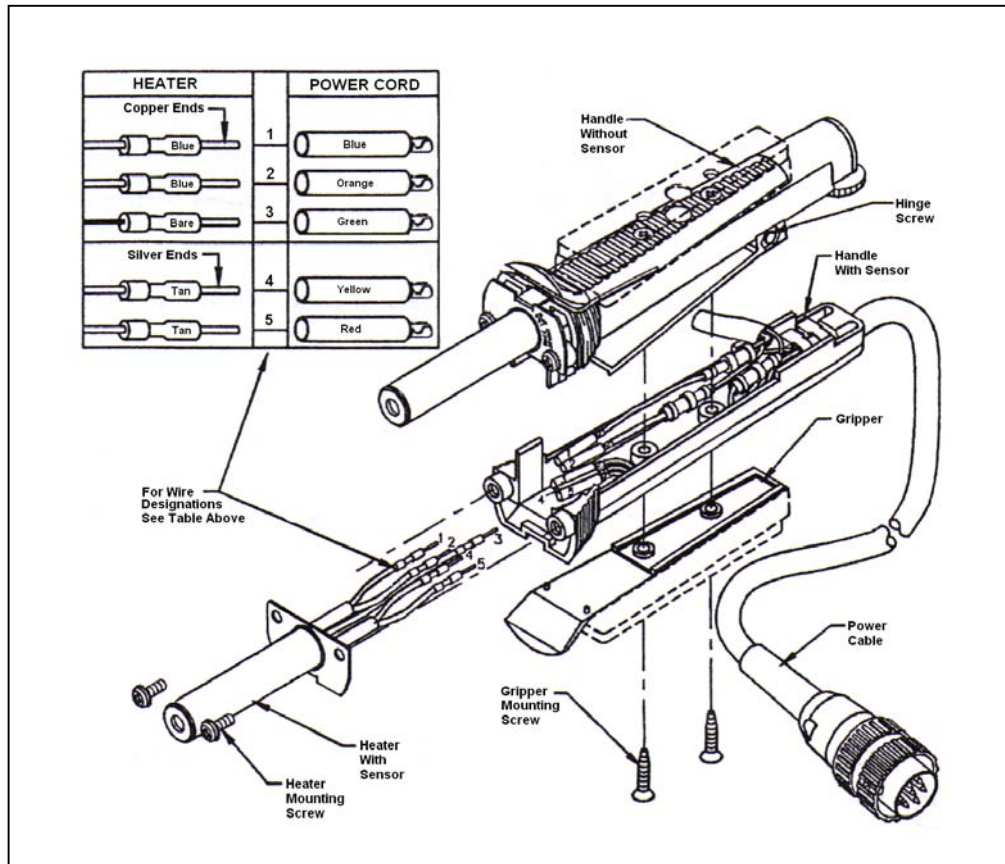

PACE Incorporated retains the right to make changes to specifications contained herein at any time, without notice. Contact your local authorized PACE Distributor or PACE Incorporated to obtain the latest specifications.

The following are trademarks and/or service marks of PACE, Incorporated, MD, USA:

INSTACAL™, FUMEFLO™, HEATWISE™, PACEWORLDWIDE™, PERMAGROUND™, POWERPORT™, POWERMODULE™, TEMPWISE™, TIP-BRITE™, AUTO-OFF™, and TEKLINK™.

The following are registered trademarks and/or service marks of PACE Incorporated, Annapolis Junction Maryland U.S.A.

ARM-EVAC®, FLO-D-SODR®, MINIWAVE®, PACE®, SENSATEMP®, SNAP-VAC®, SODRTEK®, SODR-X-TRACTOR®, THERMOFLO®, THERMOJET®, THERMOTWEEZ®, VISIFILTER®, THERMO-DRIVE®, and TOOLNET®.

PACE products meet or exceed all applicable military and civilian EOS/ESD, temperature stability and other specifications including MIL STD 2000, ANSI/JSTD 001, IPC7711, and IPC A-610.



**PACE Incorporated**  
9030 Junction Drive  
Annapolis Junction,  
MD 20701  
Tel: (301) 490-9860  
Fax: (301) 498-3252

**PACE Europe Limited**  
13 Tanners Drive  
Blakelands  
Milton Keynes  
Tel: (44) 1908-277666  
Fax: (44) 1908-277777

## X-ON Electronics

Largest Supplier of Electrical and Electronic Components

*Click to view similar products for [Pace manufacturer](#):*

Other Similar products are found below :

[1309-0018-P50](#) [8883-0111-P5](#) [6010-0150-P1](#) [8007-0522](#) [6993-0153-P1](#) [1121-0528-P5](#) [1121-0690-P5](#) [1124-1004-P1](#) [40210008-03](#) [1128-0012-P1](#) [1128-0002-P1](#) [1121-0564-P5](#) [1121-0416-P1](#) [1121-0336-P5](#) [6993-0254-P1](#) [1130-0011-P1](#) [1131-0013-P1](#) [6993-0317-P1](#) [6993-0319-P1](#) [8007-0510](#) [1207-0362-06-P1](#) [6010-0107-P1](#) [1121-0335-P5](#) [1121-0359-P5](#) [1121-0933-P5](#) [1265-0011-P1](#) [1265-0009-P1](#) [1128-0013-P1](#) [1124-1005-P1](#) [1121-0941-P5](#) [1121-0680-P5](#) [1121-0357-P5](#) [1130-0016-P1](#) [1131-0037-P1](#) [1131-0054-P1](#) [6010-0166-P1](#) [6993-0267-P1](#) [1121-0003-P2](#) [1121-0313-P1](#) [1124-0003](#) [1124-1006-P1](#) [1131-0003-P1](#) [8883-0931](#) [1121-0626-P5](#) [1128-0001-P1](#) [1124-0001-P1](#) [1121-0830-P5](#) [1131-0002-P1](#) [6993-0316-P1](#) [8883-0290](#)