



**TP-65 HEATER ASSEMBLY
PACE P/N 6010-0081-P1
INSTALLATION INSTRUCTIONS
MANUAL NUMBER 5050-0280 REV. E**

Ensure that the installed Heater Assembly of your handpiece is defective by referring to the TP-65 Heater Assembly Checkout Procedures in either of the PACE TP-65 Handpiece Manuals (P/N 5050-0295 or 5050-0335). To replace the TP-65 Heater Assembly, follow the procedure listed below using the illustration as guide to ensure optimum results:

1. Remove any attached tip and the vacuum cup from the heater end of the handpiece.
2. Disconnect the TP-65 handpiece from the power receptacle of the power source.
3. Remove the end cap, vacuum pick assembly and the metal vacuum chamber.
4. Remove the two (2) C Clips located at the rear of the handpiece.
5. Remove the two (2) Handpiece Mounting Screws which secure the top and bottom halves of the handpiece together.
6. Remove the three (3) Heater Assembly Screws. Allow the assembly to hang loose. DO NOT pull the heater from the handpiece at this time.
7. Remove the two (2) Heat Dissipator Screws which attach the Heat Dissipator to the Handpiece (Bottom). Refer to the illustration. DO NOT remove the third screw attaching the Heat Dissipator to the Handpiece (Top).
8. Remove the Handpiece (Bottom).
9. Remove the two (2) Cord & Switch Assembly Screws. Set the PCB Cover aside.
10. Using needle nose pliers, disconnect the five (5) Heater Assembly leads plugged into the Cord and Switch Assembly. Remove the defective heater from the handpiece.
11. Install the new heater leads through the Heat Dissipator. Using needle nose pliers, carefully plug the five (5) color coded leads of the replacement heater into the receptacles of the Cord & Switch Assembly. Plug the Tan leads into the receptacles along either edge of the PCB (#1 and #5; see PCB Cover markings on illustration). Plug the Green Lead into the center receptacle (#3). Plug the two (2) Blue leads into the two (2) remaining receptacles (#2 and #4).
12. Place the PCB Cover back over the Cord & Switch Assembly. Attach to the handpiece using the two (2) screws removed in step #9.
13. Reassemble the handpiece in the following order:
 - a) Replace the Handpiece (Bottom) removed in step #8.
 - b) Replace the two (2) Heat Dissipator Screws removed in step #7.
 - c) Replace the three (3) Heater Assembly Screws removed in step # 6.
 - d) Replace the two (2) Handpiece Mounting Screws removed in step #5.
 - e) Replace the two (2) C Clips removed in step #4.
 - f) Replace the metal vacuum chamber, vacuum pick assembly and the end cap assemblies removed in step #3. Replace the tip and vacuum cup.
14. Connect the handpiece to the system power source. NOTE-A small amount of smoke will be emitted for a short period of time when the heater is initially powered up.

CAUTION

Insure that the pcb receptacles face up against the PCB Cover and the cable assembly wires are not pinched during the Cord & Switch Assembly Screw installation.

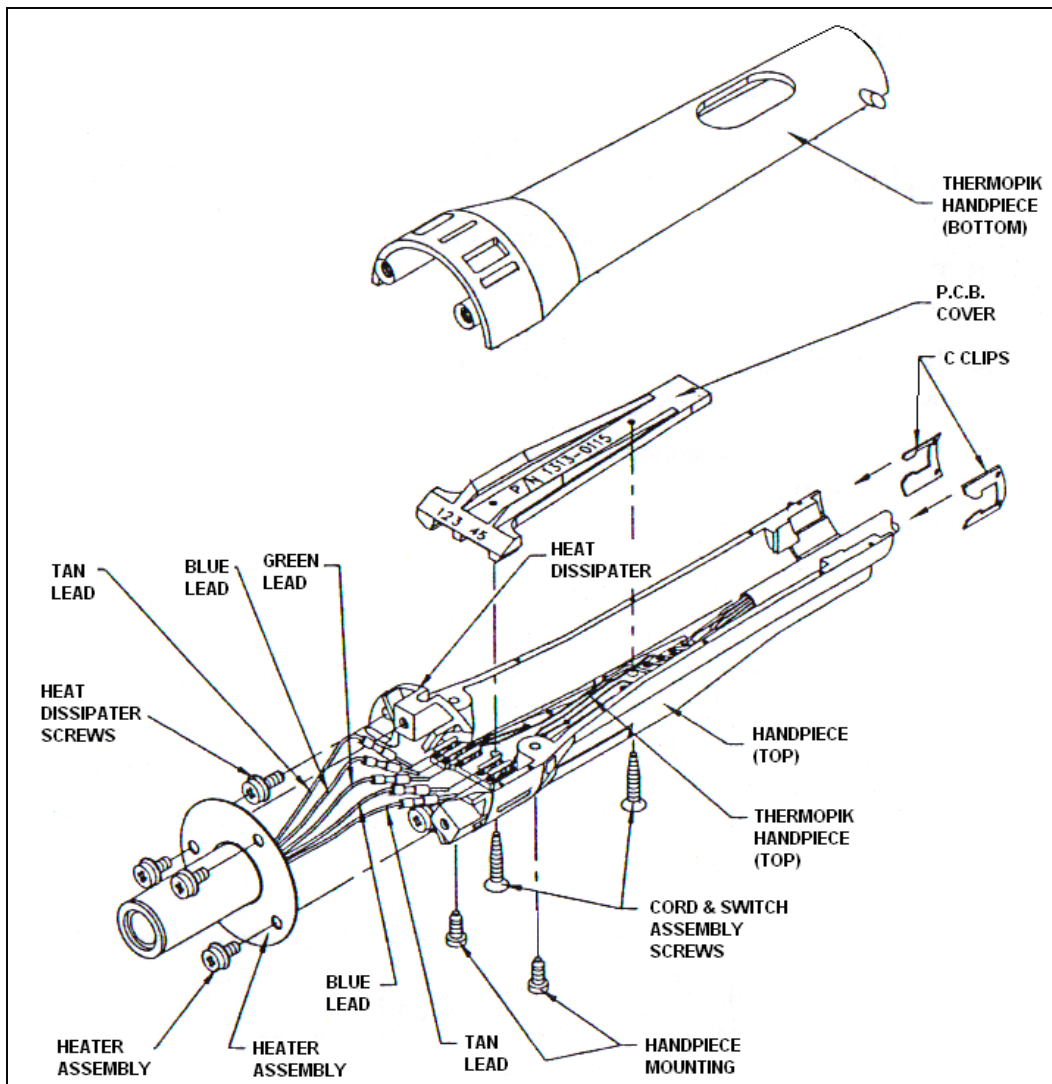

PACE Incorporated retains the right to make changes to specifications contained herein at any time, without notice. Contact your local authorized PACE Distributor or PACE Incorporated to obtain the latest specifications.

The following are trademarks and/or service marks of PACE, Incorporated, MD, USA:

INSTACAL™, FUMEFLO™, HEATWISE™, PACEWORLDWIDE™, PERMAGROUND™, POWERPORT™, POWERMODULE™, TEMPWISE™, TIP-BRITE™, AUTO-OFF™, and TEKLINK™.

The following are registered trademarks and/or service marks of PACE Incorporated, Annapolis Junction Maryland U.S.A.

ARM-EVAC®, FLO-D-SODR®, MINIWAVE®, PACE®, SENSATEMP®, SNAP-VAC®, SODRTEK®, SODR-X-TRACTOR®, ST 325®, THERMOJET®, THERMOTWEEZ®, VISIFILTER®, THERMO-DRIVE®, and TOOLNET®.

PACE products meet or exceed all applicable military and civilian EOS/ESD, temperature stability and other specifications including MIL STD 2000, ANSI/JSTD 001, IPC7711, and IPC A-610.

Additional copies of this manual or other PACE literature may be obtained from:



PACE Incorporated
 9030 Junction Drive
 Annapolis Junction,
 MD 20701
 Tel: (301) 490-9860
 Fax: (301) 498-3252

PACE Europe Limited
 13 Tanners Drive
 Blakelands
 Milton Keynes
 Tel: (44) 1908-277666
 Fax: (44) 1908-277777

X-ON Electronics

Largest Supplier of Electrical and Electronic Components

Click to view similar products for [Pace manufacturer](#):

Other Similar products are found below :

[1309-0018-P50](#) [8883-0111-P5](#) [6010-0150-P1](#) [8007-0522](#) [6993-0153-P1](#) [1121-0528-P5](#) [1121-0690-P5](#) [1124-1004-P1](#) [40210008-03](#) [1128-0012-P1](#) [1128-0002-P1](#) [1121-0564-P5](#) [1121-0416-P1](#) [1121-0336-P5](#) [6993-0254-P1](#) [1130-0011-P1](#) [1131-0013-P1](#) [6993-0317-P1](#) [6993-0319-P1](#) [8007-0510](#) [1207-0362-06-P1](#) [6010-0107-P1](#) [1121-0335-P5](#) [1121-0359-P5](#) [1121-0933-P5](#) [1265-0011-P1](#) [1265-0009-P1](#) [1128-0013-P1](#) [1124-1005-P1](#) [1121-0941-P5](#) [1121-0680-P5](#) [1121-0357-P5](#) [1130-0016-P1](#) [1131-0037-P1](#) [1131-0054-P1](#) [6010-0166-P1](#) [6993-0267-P1](#) [1121-0003-P2](#) [1121-0313-P1](#) [1124-0003](#) [1124-1006-P1](#) [1131-0003-P1](#) [8883-0931](#) [1121-0626-P5](#) [1128-0001-P1](#) [1124-0001-P1](#) [1121-0830-P5](#) [1131-0002-P1](#) [6993-0316-P1](#) [8883-0290](#)