

---

---

**MGC3140 3D Tracking and Gesture Controller Data Sheet**

---

---

---

## Introduction

---

Microchip's MGC3140 is a 3D gesture and motion tracking controller based on Microchip's patented GestIC<sup>®</sup> technology – suitable for consumer, industrial and automotive applications. It enables robust user interfaces with natural hand and finger movements utilizing the principles of electrical near-field sensing.

Implemented as a low-power mixed-signal configurable controller, the MGC3140 provides a compelling set of smart functional features such as gesture recognition while using adaptive working frequencies for robust performance in noisy environments. Microchip's on-chip Colibri gesture suite removes the need for host post-processing and reduces system power consumption, resulting in low software development efforts for short time-to-market success.

The MGC3140 represents a unique and high-performance single-chip gesture solution focusing on automotive applications. MGC3140 provides proximity, gesture detection and driver recognition, thus enabling modern and compelling user interfaces to be created.

---

## MGC3140 Applications

---

- Automotive Applications
- IoT
- Audio Products
- Notebooks/Keyboards/PC Peripherals
- Home Automation
- White Goods
- Switches
- Medical Products
- Game Controllers

---

## Power Operation Modes

---

Several Power Operation Modes Including:

- Processing Mode: 29 mA, typical
- Deep Sleep: 85  $\mu$ A, typical

---

## Key Features

---

- Automotive Qualification AEC Q100 Grade 1
- Recognition of 3D Hand Gestures and x, y, z Positional Data
- Proximity and Touch Sensing

- Built-in Colibri Gesture Suite (running on-chip)
- Advanced 3D Signal Processing Unit
- Detection Range: 0 to 10 cm, typical
- Receiver Sensitivity: <1 fF
- Position Rate: 200 positions/sec.
- Spatial Resolution: up to 150 dpi
- Carrier Frequency: 42, 43, 44, 45, 100 kHz
- Channels Supported:
  - Five receive (Rx) channels
  - One transmit (Tx) channel
- On-chip Auto-Calibration
- Low-Noise Radiation due to Low-Transmit Voltage and Slew Rate Control
- Noise Susceptibility Reduction:
  - On-chip analog filtering
  - On-chip digital filtering
  - Automatic frequency hopping
- Enables the use of Low-Cost Electrode Material including:
  - Printed circuit board
  - Conductive paint
  - Conductive foil
  - Laser Direct Structuring (LDS)
  - Touch panel ITO structures
- Field Upgrade Capability
- Operating Voltage:  $V_{DD} = 3.3V \pm 5\%$
- Operating Temperature Range:  $-40^{\circ}C$  to  $+125^{\circ}C$

## Peripheral Features

- I<sup>2</sup>C for Configuration and Sensor Output Streaming I<sup>2</sup>C, speed up to 400 kHz

## Packages

Part Number	Available Package	Pins	Contact/Lead Pitch	Dimensions
MGC3030	SSOP	28	0.65	7.8x10.2x1.9
MGC3130	QFN	28	0.5	5x5x0.9
MGC3140	UQFN	48	0.4	6x6x0.5

**Note:** All dimensions are in millimeters (mm), unless specified.

Part Number	Gesture Recognition	Position Tracking	Raw Data Streaming	Wake-Up-On-Approach	Deep Sleep	Gesture Port Pins	Rx Receive Electrodes	I <sup>2</sup> C Ports	AEC-Q100 Qualified (PPAP)
MGC3030	Yes	No	Yes	Yes	Yes	5	5	1	No
MGC3130	Yes	Yes	Yes	Yes	Yes	5	5	1	No
MGC3140	Yes	Yes	Yes	Yes	Yes	5	5	1	Yes

**Note:**

1. MGC3030 recommended for new Industrial designs.
2. MGC3130 recommended for new Industrial designs.
3. MGC3140 recommended for Automotive designs.

---

**Table of Contents**

---

Introduction.....	1
MGC3140 Applications.....	1
Power Operation Modes.....	1
Key Features.....	1
Peripheral Features.....	2
Packages.....	2
1. Pin Diagram.....	6
2. 48-Pin Allocation and Pinout Description Table.....	7
3. Theory of Operation: Electrical Near-Field (E-Field) Sensing.....	9
4. Feature Description.....	11
5. System Architecture.....	17
6. Functional Description.....	21
7. Interface Description.....	29
8. Application Architecture.....	34
9. Development Support.....	36
10. Electrical Specifications.....	37
11. Packaging Information.....	41
The Microchip Web Site.....	45
Customer Change Notification Service.....	45
Customer Support.....	45
Product Identification System.....	46
Microchip Devices Code Protection Feature.....	47
Legal Notice.....	47
Trademarks.....	47

Quality Management System Certified by DNV.....48  
Worldwide Sales and Service.....49

## 1. Pin Diagram

Figure 1-1. MGC3140 48L Diagram UQFN

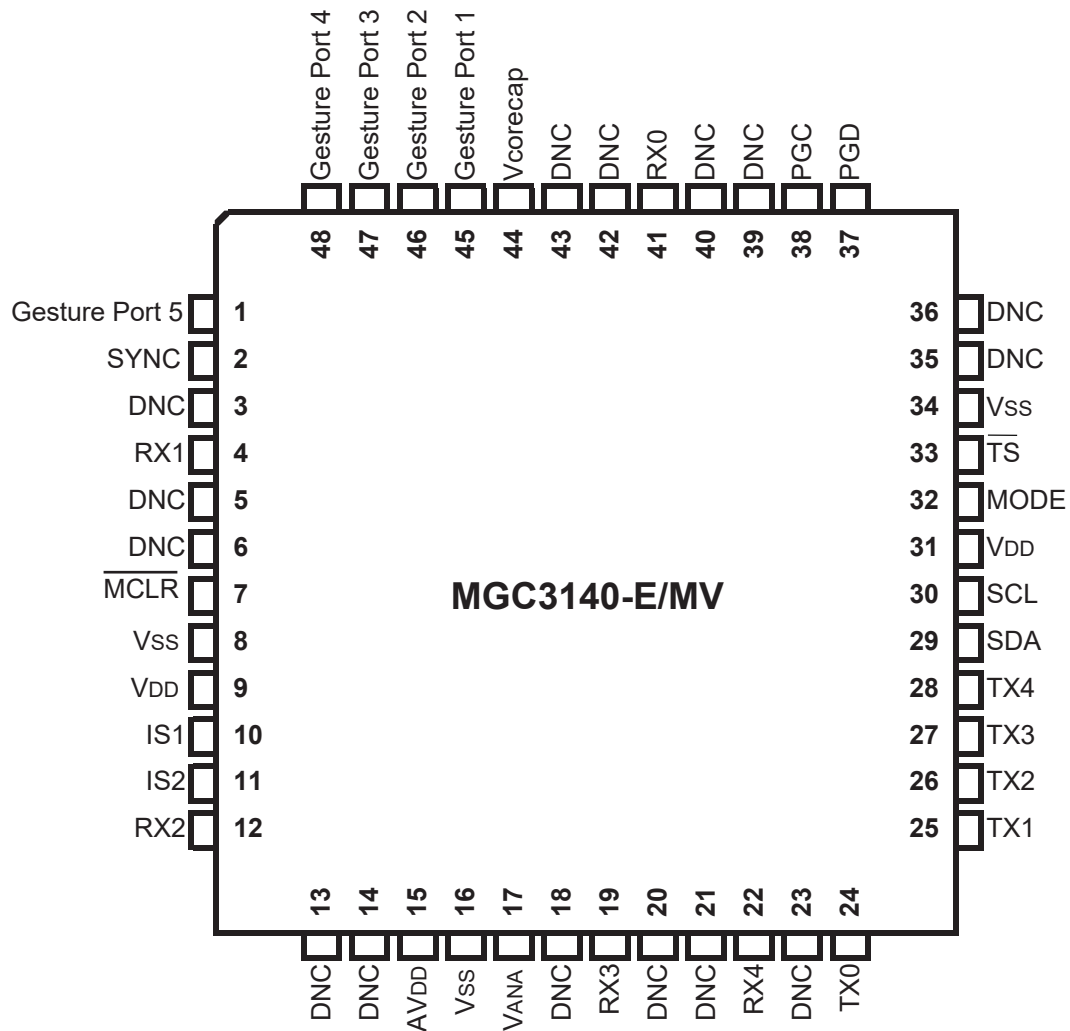

### Related Links

- [2. 48-Pin Allocation and Pinout Description Table](#)

## 2. 48-Pin Allocation and Pinout Description Table

Pin Name	Pin Number	Pin Type	Buffer Type	Description
GP5	1	O	—	Gesture Port 5.
SYNC	2	O	—	Gesture device synchronization pulse (every 1 ms).
DNC	3	—	—	not connected
RX1	4	I	Analog	Analog GestIC <sup>®</sup> input channel 1: Receive electrode connection.
DNC	5	—	—	not connected
DNC	6	—	—	not connected
$\overline{\text{MCLR}}$	7	I	—	Master Clear (Reset) input. This pin is an active-low Reset to the device.
V <sub>SS</sub>	8	P	—	Ground reference for logic and I/O pins. This pin must be connected at all times.
V <sub>DD</sub>	9	P	—	Positive supply for peripheral logic and I/O pins.
IS1	10	I	ST	Interface Selection Pin 1
IS2	11	I	ST	Interface Selection Pin 2
RX2	12	I	Analog	Analog GestIC <sup>®</sup> input channel 2: Receive electrode connection.
DNC	13	—	—	not connected
DNC	14	—	—	not connected
AV <sub>DD</sub>	15	P	—	Positive supply for analog modules. This pin must be connected at all times.
V <sub>SS</sub>	16	P	—	Ground reference for analog modules.
V <sub>ANA</sub>	17	P	—	Positive supply for analog front end.
DNC	18	—	—	not connected
RX3	19	I	Analog	Analog GestIC <sup>®</sup> input channel 3: Receive electrode connection.
DNC	20	—	—	not connected
DNC	21	—	—	not connected
RX4	22	I	Analog	Analog GestIC <sup>®</sup> input channel 4: Receive electrode connection.
DNC	23	—	—	not connected
TX0	24	O	—	GestIC <sup>®</sup> Transmit electrode connection 0.
TX1	25	O	—	GestIC <sup>®</sup> Transmit electrode connection 1.
TX2	26	O	—	GestIC <sup>®</sup> Transmit electrode connection 2.
TX3	27	O	—	GestIC <sup>®</sup> Transmit electrode connection 3.
TX4	28	O	—	GestIC <sup>®</sup> Transmit electrode connection 4.
SDA	29	I/O	ST	Synchronous serial data input/output for I <sup>2</sup> C.
SCL	30	I/O	ST	Synchronous serial clock input/output for I <sup>2</sup> C.

## 48-Pin Allocation and Pinout Description Table

Pin Name	Pin Number	Pin Type	Buffer Type	Description
V <sub>DD</sub>	31	P	—	Positive supply for peripheral logic and I/O pins.
MODE	32	I	ST	Gesture Devices Scan mode: High: 2D touch device measuring; Low: gesture device measuring
$\overline{TS}$	33	O	—	Transfer Status. GestIC <sup>®</sup> message ready interrupt.
V <sub>SS</sub>	34	P	—	Ground reference for analog modules. This pin must be connected at all times.
DNC	35	—	—	not connected
DNC	36	—	—	not connected
PGD	37	I/O	ST	Programming Data line, connect to test pin in application.
PGC	38	I/O	ST	Programming Clock line, connect to test pin in application.
DNC	39	—	—	not connected
DNC	40	—	—	not connected
RX0	41	I	Analog	Analog GestIC <sup>®</sup> input channel 0: Receive electrode connection.
DNC	42	—	—	not connected
DNC	43	—	—	not connected
V <sub>CORECAP</sub>	44	P	—	Capacitor for Internal Voltage Regulator.
GP1	45	O	—	Gesture Port 1.
GP2	46	O	—	Gesture Port 2.
GP3	47	O	—	Gesture Port 3.
GP4	48	O	—	Gesture Port 4.
<b>Legend:</b>				
Analog = Analog input				
P = Power				
ST = Schmitt Trigger input with CMOS levels				
I = Input				
O = Output				
I/O = Input/Output				
— = N/A				



**Important:** Exposed pad must be connected to V<sub>SS</sub>.

### Related Links

- [1. Pin Diagram](#)



### 3. Theory of Operation: Electrical Near-Field (E-Field) Sensing

Microchip's GestIC technology is a 3D sensor technology which utilizes an electric field (E-field) for advanced proximity sensing. It allows realization of new user interface applications by detection, tracking and classification of a user's hand gestures in free space.

E-fields are generated by electrical charges and propagate three-dimensionally around the surface, carrying the electrical charge.

Applying direct voltages (DC) to an electrode results in a constant electric field. Applying alternating voltages (AC) makes the charges vary over time and, thus, the field. When the charge varies sinusoidally with frequency 'f', the resulting electromagnetic wave is characterized by wavelength  $\lambda = c/f$ , where 'c' is the wave propagation velocity — in vacuum, the speed of light. In cases where the wavelength is much larger than the electrode geometry, the magnetic component is practically zero and no wave propagation takes place. The result is quasi-static electrical near field that can be used for sensing conductive objects such as the human body.

Microchip's GestIC technology uses five transmit (Tx) frequencies, 42, 43, 44, 45 and 100 kHz, with wavelengths of at least three kilometers. This wavelength is much larger than the typical range of electrode dimensions between 5 mm and 20 mm. GestIC systems work without wave propagation.

In case a person's hand or finger intrudes the electrical field, the field becomes distorted. The field lines are drawn to the hand due to the conductivity of the human body itself and shunted to ground. The 3D electric field decreases locally. Microchip's GestIC technology uses a minimum number of four receiver (Rx) electrodes to detect the E-field variations at different positions to measure the origin of the electric field distortion from the varying signals received. The information is used to calculate the position, track movements and classify movement patterns (gestures).

The two following figures show the influence of an earth-grounded body to the electric field. The proximity of the body causes a compression of the equipotential lines and shifts the Rx electrode signal levels to a lower potential which is measured.

**Figure 3-1. Equipotential Lines of an Undistorted E-Field**

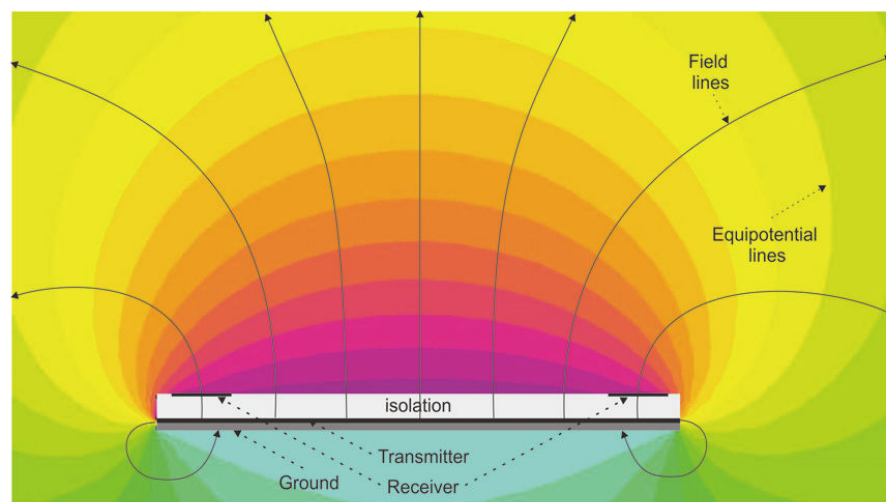
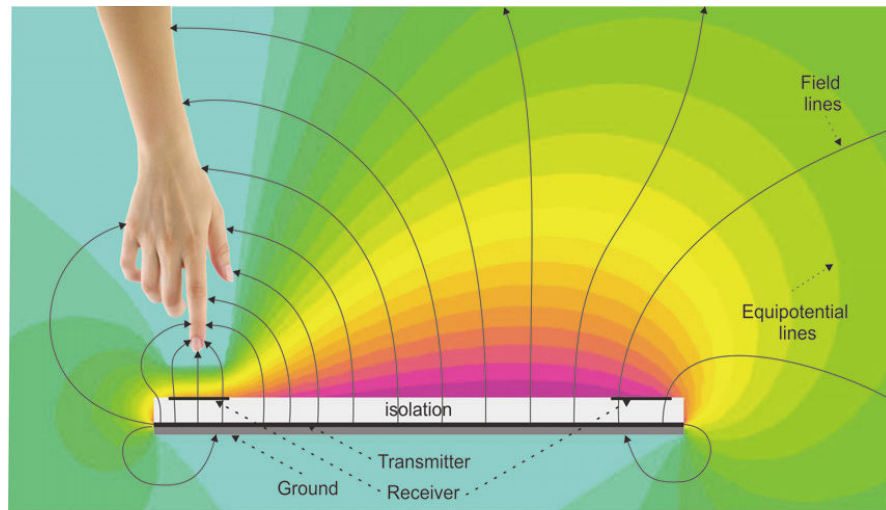

Figure 3-2. Equipotential Lines of a Distorted E-Field



### 3.1 GestIC Technology Benefits

- GestIC E-field sensors are not impacted by ambient influences such as light or sound, which have a negative impact to the majority of other 3D technologies.
- GestIC technology allows gesture/position tracking processing on-chip – no host processing needed. Algorithms are included in the Colibri Gesture Suite which runs on-chip and is provided by Microchip.
- The GestIC technology has a high immunity to noise, provides high update rates and resolution, low latency and is also not affected by clothing, surface texture or reflectivity.
- Five carrier frequencies of 42, 43, 44, 45 and 100 kHz are utilized by the GestIC with minimal impact on the regulated radio frequency range.
- Usage of thin low-cost materials as electrodes allow low system cost at slim Industrial designs.
- The further use of existing capacitive sensor structures, such as a touch panel's ITO coating, allows additional cost savings and ease the integration of the technology.
- Electrodes are invisible to the user's eye since they are implemented underneath the housing surface or integrated into a touch panel's ITO structure.
- GestIC works centrally over the full sensing space. Thus, it provides full surface coverage without any detection blind spots.
- Only one GestIC transmitter electrode is used for E-field generations. The benefit is an overall low power consumption and low radiated EMC noise.
- Since GestIC is basically processing raw electrode signals and computes them in real time into preprocessed gestures and x, y, z positional data, it provides a highly-flexible user interface technology for any kind of electronic devices.

## 4. Feature Description

### 4.1 Gesture Definition

A hand gesture is the movement of the hand to express an idea or meaning. The GestIC technology accurately allows sensing of a user's free space hand motion for contact free position tracking, as well as 3D gesture recognition based on classified movement patterns.

### 4.2 GestIC Library

MGC3140 is being provided with a GestIC Library loader (bootloader) which is stored on the chip's Flash memory. Using this loader, a GestIC Library can be flashed on the MGC3140 via I<sup>2</sup>C using, for example, an embedded host controller or Microchip's Aurea GUI. The GestIC Library includes:

- Colibri Suite: Digital Signal Processing (DSP) algorithms and feature implementations.
- System Control: MGC3140 hardware control.

#### Related Links

[9.1 Aurea Software Package](#)

#### 4.2.1 Colibri Suite

The Colibri Suite combines data acquisition, digital signal processing and interpretation.

The Colibri Suite functional features are illustrated below and described in the following sections.

**Figure 4-1. Colibri Suite Core Elements**

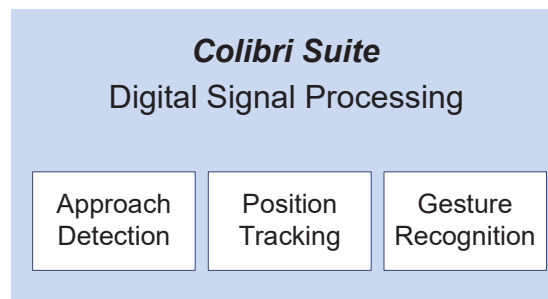

##### 4.2.1.1 Position Tracking

The Colibri Suite's Position Tracking feature provides 3D hand position over time and area. The absolute position data is provided according to the defined origin of the Cartesian coordinate system (x, y, z). Position Tracking data is continuously acquired in parallel to Gesture Recognition. With a position rate of up to 200 positions/sec., a maximum spatial resolution of 150 dpi is achieved.

##### 4.2.1.2 Gesture Recognition

The Colibri Suite's gesture recognition model detects and classifies hand movement patterns performed inside the sensing area.

Using advanced random classification based on Hidden Markov Model (HMM), industry best gesture recognition rate is being achieved.

The Colibri Suite includes a set of predefined hand gestures which contains Flick, Circular and Symbol gestures as the ones outlined below:

### **Flick Gestures**

**Figure 4-2. Flick Gestures**



A Flick gesture is a unidirectional gesture in a quick flicking motion. An example may be a hand movement from West to East within the sensing area, from South to North, etc.

### **Circular Gestures**

**Figure 4-3. Circle Gestures**

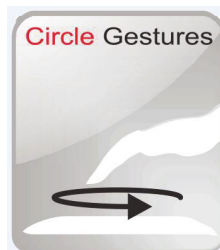

A circular gesture is a round-shaped hand movement defined by direction (clockwise/counterclockwise) without any specific start position of the user's hand. Two types of circular gestures are distinguished by GestIC technology:

1. **AirWheel**

- An AirWheel is the recognition of continuously-performed rotations inside the sensing area and provides information about the rotational movement in real time. It provides continuously counter information which increments/decrements according to the movement's direction (clockwise/counterclockwise). The AirWheel can be adjusted for convenient usage in various applications (e.g., volume control, sensitivity adjustment or light dimming).

2. **Discrete Circles**

- Discrete Circles are recognized after performing a hand movement inside the sensing area. The recognition result (direction: clockwise/counterclockwise) is provided after the hand movement stops or the hand exits the detection area. The Discrete Circles are typically used as dedicated application control commands.

### **Hold and Presence Gestures**

Hold/Presence gestures are recognized through the detection of a hand within a configurable detection area. After the hand is detected as being present in this area, a timer will be started. If the hand stays

within the detection area until a certain timer value is reached, the Presence gesture is detected. The timer value is configurable. The Presence gesture is typically used for lighting up back-lights as if the hand is in the detection area and does not move; a second timer is started.

Presence and Hold gestures are triggered upon a time-out in a defined Status flag. If a Status flag is active during a certain amount of time, after its last rising edge, the corresponding gesture is triggered.

The Status flags that can trigger one of these gestures are:

- **Hand Presence** flag is active while the user's hand is in the sensing space.
- **Hand Inside** flag is active while the user's hand is in the sensing space approximately centered above the sensor.
- **Hand Hold** flag is active while the hand is not moving and one of the above Status flags is active, the selection depends on ActiveOutside.

The behavior of the Status flags and corresponding gestures can be adjusted to suit a specific application. The Gesture and Presence/Hold state visualization windows offer immediate feedback upon adjustment.

The adjustable parameters are:

### 1. **ActiveOutside**

- Chooses if Hand Hold flag and Presence gesture can be active when the user is outside the sensor, but still in sensing space.
  - ActiveOutside *checked* (default) means that Hand Presence is required to set Hand Hold and that Presence Duration starts counting on the rising edge of Hand Presence Status flag;
  - ActiveOutside *unchecked* means that Hand Inside is required to set Hand Hold and that Presence Duration starts counting on the rising edge of Hand Inside Status flag.

### 2. **Presence Duration**

- This is the time during which the selected Status flag must be active to trigger a Presence gesture. This time starts counting on the last rising edge of the selected Status flag. The gesture is only triggered once for each rising edge of the flag.

### 3. **Hold Duration**

- This is the time during which the Holding Hand flag must be active to trigger a Hold gesture. This time starts counting on the last rising edge of the Holding Hand flag. The gesture is only triggered once for each rising edge of the flag.

### 4. **Hold Tremble Threshold**

- This value specifies how much the hand can move and still be considered as holding. For high values, the hand can move while the Hand Hold flag is still high. For low values, only a slight movement is necessary to clear the Hand Hold flag.

## Sensor Touch Gestures

Figure 4-4. Sensor Touch

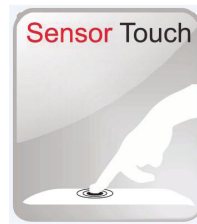

A Sensor Touch is a multi-zone gesture that reports up to five concurrently-performed touches on the system's electrodes.

The Sensor Touch provides information about touch and tapping:

1. The Sensor Touch indicates an event during which a GestIC electrode is touched. This allows distinction between short and long touches.
2. The Tap and Double Tap signalize short taps and double taps on each system electrode. The tap length and double tap interval are adjustable.
  - **Single Tap Delay:** A single tap is detected when touching the surface of an electrode first and after the hand is pulled out of the touch area. The Single Tap is only detected when the timing between the touch and the release of the touch event is smaller than the adjusted delay. Increasing the time allows the user more time to perform the tap. The range for the adjusted delay can range between 0s and 1s.
  - **Double Tap Delay:** The double tap is detected when two taps are performed within the adjusted delay. The range for the adjusted delay can range between 0s and 1s. The smaller the selected delay is, the faster the two taps have to be executed.

**Figure 4-5. Sensor Touch Diagram**

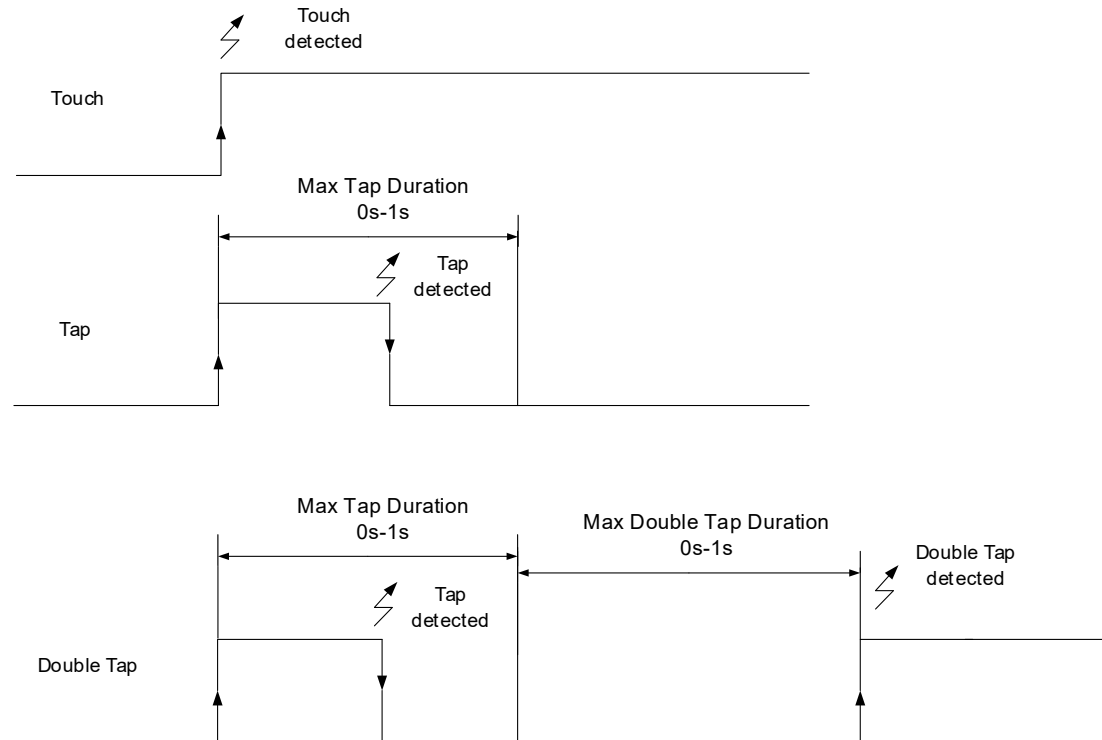

**4.2.1.3 Approach Detection**

**Figure 4-6. Approach Detection**



Approach Detection is an embedded power-saving feature of Microchip’s Colibri Suite. It sends MGC3140 to Sleep mode and scans periodically the sensing area to detect the presence of a human hand. Utilizing the built-in Self Wake-up mode, Approach Detection alternates between Sleep and Scan phase. During the Scan phase, the approach of a human hand can be detected while very low power is consumed.

A detected approach of a user exceeding configured threshold criteria will alternate the MGC3140 from Self Wake-up to Processing mode or even the application host in the overall system.

Within the Approach Detection sequence, the following scans are performed:

- **Approach Scan**

- An Approach scan is performed during the scan phase of the device’s Self Wake-up mode. Typically, one Rx channel is active but more channels can be activated via the GestIC Library. The time interval (scan interval) between two consecutive Approach scans is configurable. For typical applications, the scan cycle is in a range of 20 ms to 150 ms. During the Approach scan, the activated Rx channels are monitored for signal changes which are caused by, for example, an approaching human hand and exceeding the defined threshold. This allows an autonomous wake-up of the MGC3140 and host applications at very low-power consumption.
- **AFA Scan**
  - During Wake-up-on-Approach, periodic Automatic Frequency Adaptation (AFA) scans are performed. During this scan, the environmental noise is measured and a new Tx frequency will be selected from the five preset frequencies available, if necessary. The AFA scan is usually performed in configurable intervals from 120s to 600s (120s typical). The timing sequence of the Approach Detection feature is illustrated below:

**Figure 4-7. Approach Detection Sequence**

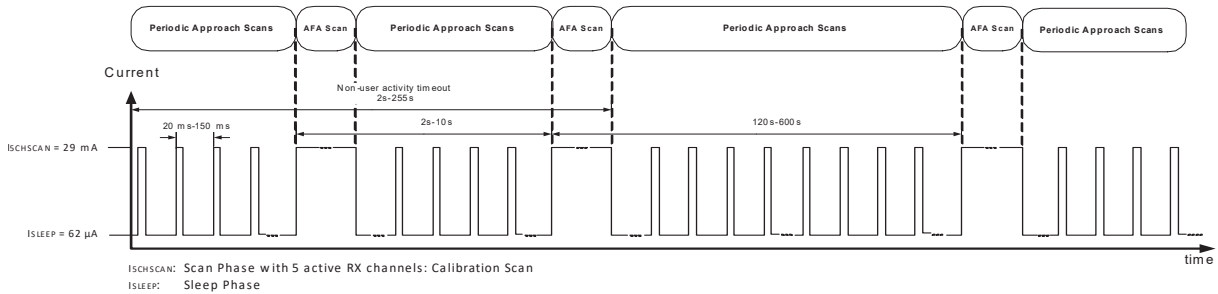

**Related Links**

[6.4.3 Wake-up-on-Approach Mode](#)



## 5. System Architecture

MGC3140 is a mixed-signal configurable controller. The entire system solution is composed of the following main building blocks (see diagram below):

- MGC3140 Controller
- GestIC Library
- External Electrodes

**Figure 5-1. MGC3140 Controller System Architecture**

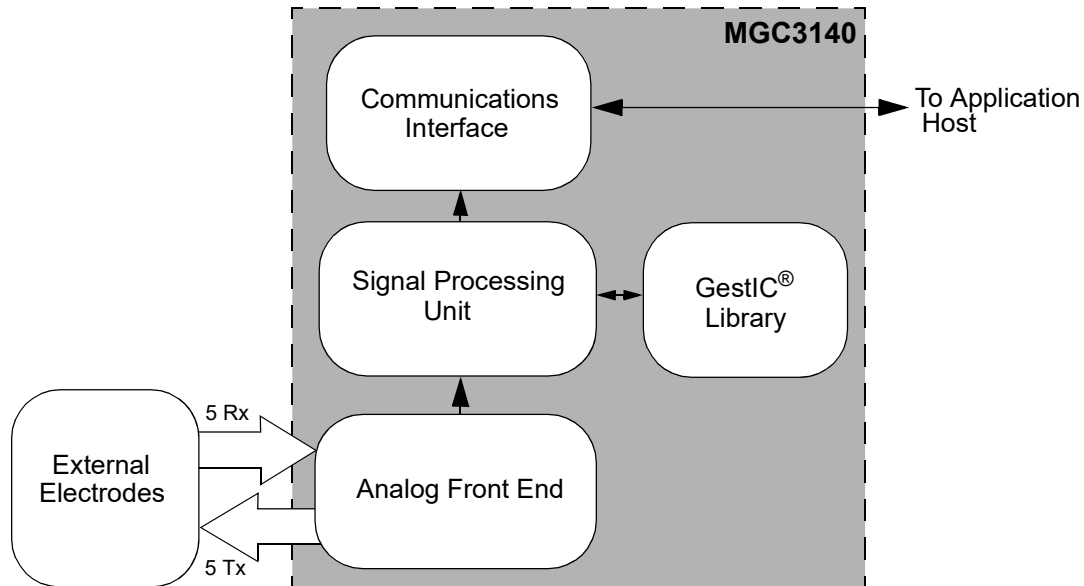

### 5.1 MGC3140 Controller

The MGC3140 features the following main building blocks:

- Low-Noise Analog Front End (AFE)
- Digital Signal Processing Unit (SPU)
- Communication Interfaces

The MGC3140 provides a transmit signal to generate the E-field, conditions the analog signals from the receiving electrodes and processes these data digitally on the SPU. Data exchange between the MGC3140 and a host is conducted via the controller's I<sup>2</sup>C interface.

#### Related Links

[6. Functional Description](#)

### 5.2 GestIC<sup>®</sup> Library

The embedded GestIC Library is optimized to ensure continuous and Real-Time Free-Space gesture recognition and motion tracking concurrently. It is fully-configurable and allows required parametrization for individual application and external electrodes.

### 5.3 External Rx Electrodes

Rx electrodes are connected to the MGC3140. An electrode needs to be individually designed following the guide lines from the "GestIC Design Guide" (DS40001716), for optimal E-field distribution and detection of E-field variations inflicted by a user.

#### 5.3.1 Electrode Equivalent Circuit

The hand position tracking and gesture recognition capabilities of a GestIC system depend on the electrode design and their material characteristics.

A simplified equivalent circuit model of a generic GestIC electrode system is illustrated in the following figure:

**Figure 5-2. Electrodes Capacitive Equivalent Circuitry Earth Grounded**

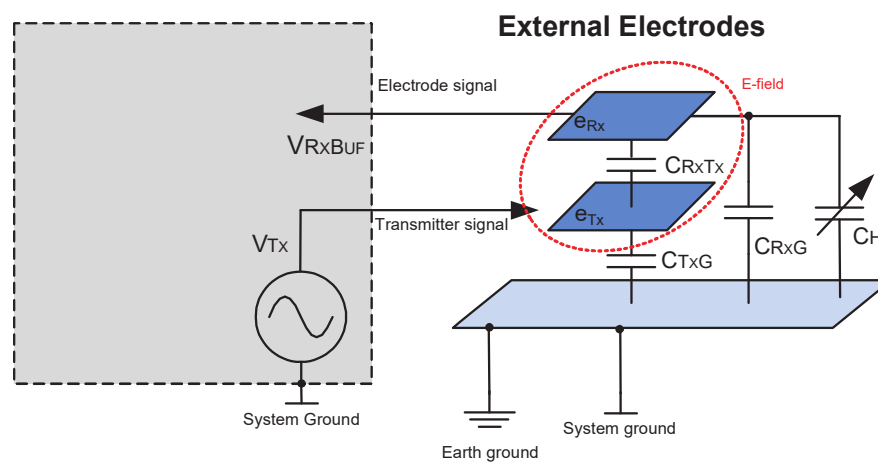

$V_{Tx}$  Tx electrode voltage

$V_{RxBUF}$  MGC3140 Rx input voltage

$C_H$  Capacitance between receive electrode and hand (earth ground). The user's hand can always be considered as earth-grounded due to the comparable large size of the human body.

$C_{RxTx}$  Capacitance between receive and transmit electrodes

$C_{RxG}$  Capacitance of the receive (Rx) electrode to system ground + input capacitance of the MGC3140 receiver circuit

$C_{TxG}$  Capacitance of the transmit (Tx) electrode to system ground

$e_{Rx}$  Rx electrode

$e_{Tx}$  Tx electrode

The Rx and Tx electrodes in a GestIC electrode system build a capacitance voltage divider with the capacitances  $C_{RxTx}$  and  $C_{RxG}$  which are determined by the electrode design.  $C_{TxG}$  represents the Tx electrode capacitance to system ground driven by the Tx signal. The Rx electrode measures the potential of the generated E-field. If a conductive object (e.g., a hand) approaches the Rx electrode,  $C_H$  changes its capacitance. Femtofarad changes are detected by the MGC3140 receiver. The equivalent circuit formula for the earth-grounded circuitry is described in the following equation:

**Equation 5-1. Electrodes Equivalent Circuit**

$$V_{RxBuf} = V_{Tx} \times \frac{C_{RxTx}}{C_{RxTx} + C_{RxG} + C_H}$$

A common example of an earth-grounded device is a notebook, even with no ground connection via power supply or Ethernet connection. Due to its larger form factor, it presents a high earth-ground capacitance in the range of 50 pF and, thus, it can be assumed as an earth-grounded GestIC system. For further information on sensor designs with earth-grounded as well as nonearth-grounded devices, see "[GestIC Design Guide](#)" (DS40001716).

A brief overview of the typical values of the electrode capacitances is summarized in the table below:

**Table 5-1. Electrode Capacitances Typical Values**

Capacity	Typical value
$C_{RxTx}$	10...30 pF
$C_{TxG}$	10...1000 pF
$C_{RxG}$	10...30 pF
$C_H$	<1 pF



**Important:** Ideal designs have low  $C_{RxTx}$  and  $C_{RxG}$  to ensure higher sensitivity of the electrode system. Optimal results are achieved with  $C_{RxTx}$  and  $C_{RxG}$  values being in the same range.

**5.3.2 Standard Electrode Design**

The MGC3140 electrode system is typically a double-layer design with a Tx transmit electrode at the bottom layer to shield against device ground and, thus, ensure high-receive sensitivity. Up to five comparably smaller Rx electrodes are placed above the Tx layer providing the spatial resolution of the GestIC system. Tx and Rx are separated by a thin isolating layer. The Rx electrodes are typically arranged in a frame configuration as shown in the following electrode diagrams.

The frame defines the inside sensing area.

Larger dimensions yield in higher sensitivity of the system.

For more information on sensor design as well as the function of the center electrode, see "[GestIC Design Guide](#)" (DS40001716).

The electrode shapes can be designed solid or structured. In addition to the distance and the material between the Rx and Tx electrodes, the shape structure density also controls the capacitance  $C_{RxTx}$  and thus, the sensitivity of the system.

Figure 5-3. Frame Shape Electrodes

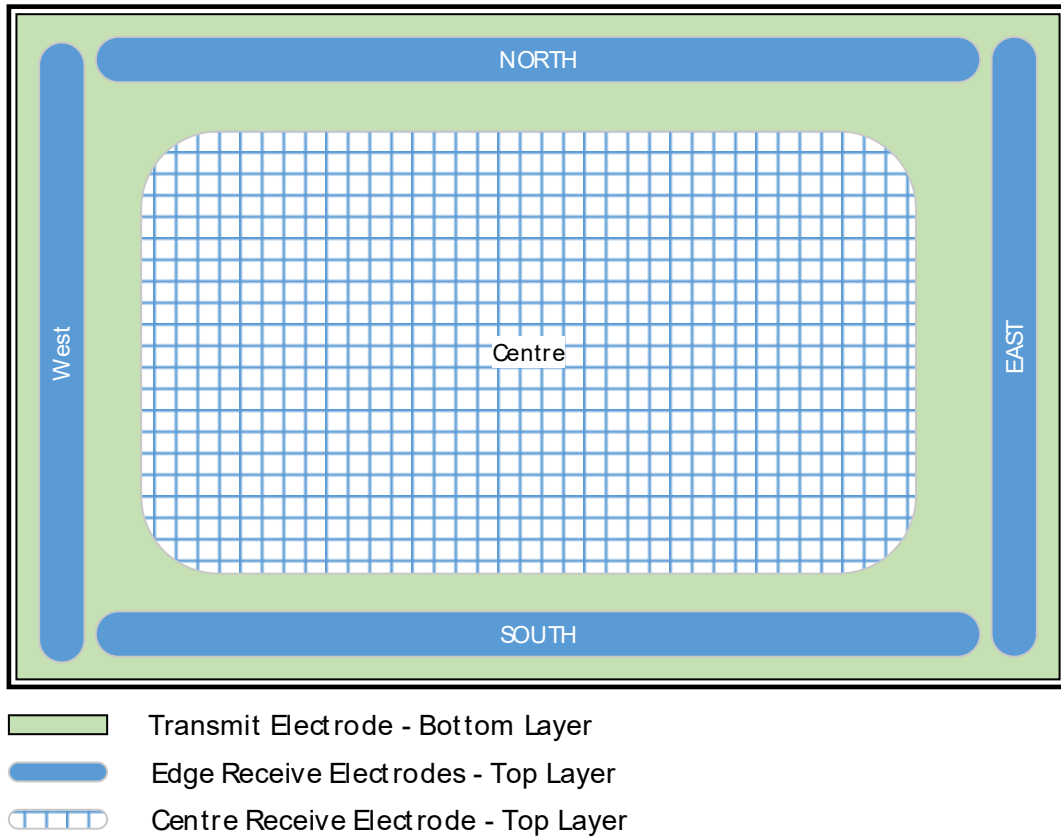

## 6. Functional Description

Microchip Technology's GestIC technology utilizes electrical near-field (E-field) sensing. The chip is connected to electrodes that are sensing the E-field variance. The GestIC device then calculates the user's hand motion relatively to the sensing area in x, y, z position data, and classifies the movement pattern into gestures in real time. In addition, by utilizing the principles of E-field sensing, the GestIC system is immune to ambient influences such as light or sound, which have a negative impact on the majority of other 3D technologies. Also, it allows full-surface coverage of the electrode area with no detection blind spots of a user's action.

Microchip Technology's MGC3140 is a configurable controller. Featuring a Signal Processing Unit (SPU), a wide range of 3D gesture applications are being processed on the MGC3140, which allows short development cycles. Always-on 3D sensing is enabled, even for battery-driven devices, by the chip's low-power design and the variety of programmable power modes. GestIC sensing electrodes are driven by a low-voltage signal with frequencies of 42, 43, 44, 45, and 100 kHz, allowing their electrical conductive structure to be made of any low-cost material. Figure 6-1 provides an overview of the main building blocks of MGC3140.

**Figure 6-1. MGC3140 Block Diagram**

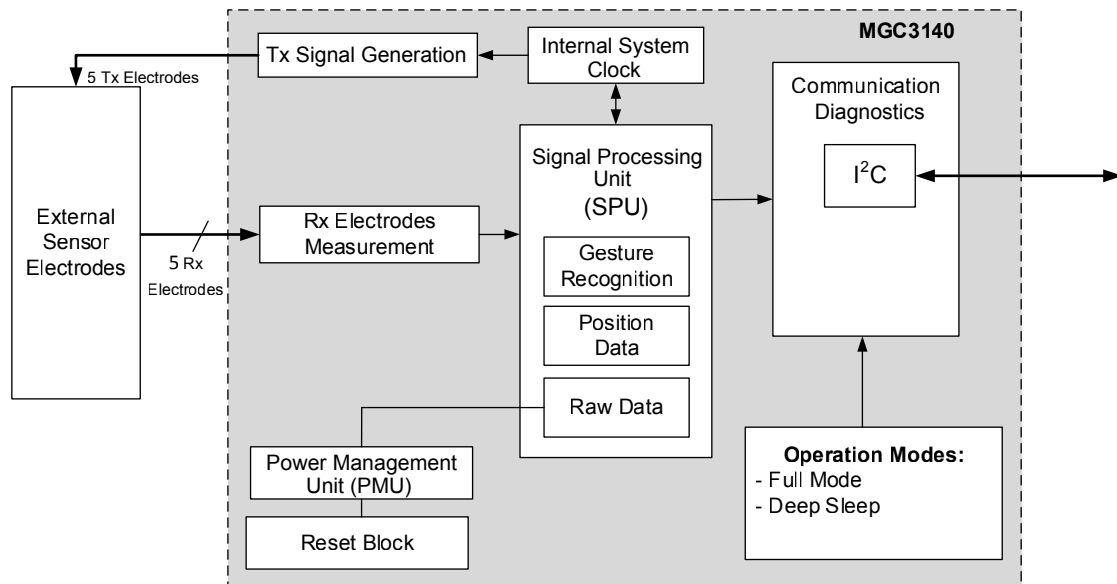

### 6.1 Reset

The Reset block combines all Reset sources. It controls the device system's Reset signal (SYSRST). The following is a list of device Reset sources:

- $\overline{\text{MCLR}}$ : Master Clear Reset pin
- SWR: Software Reset available through GestIC Library Loader
- Power-on Reset (POR)
- Brown-out Reset (BOR)
- Watchdog Timer Reset (WDTR)

A simplified block diagram of the Reset block is illustrated in the following figure.

A pull-up resistor of 10 kΩ must be connected at all times to the  $\overline{\text{MCLR}}$  pin.

**Figure 6-2. System Reset Block Diagram**

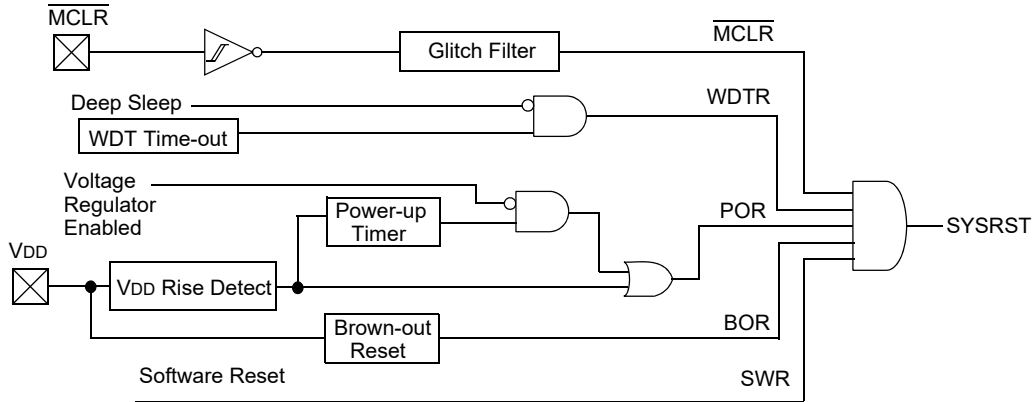

Timing Diagrams for POR and BOR are shown below:

**Figure 6-3. Power-on Reset Timing**

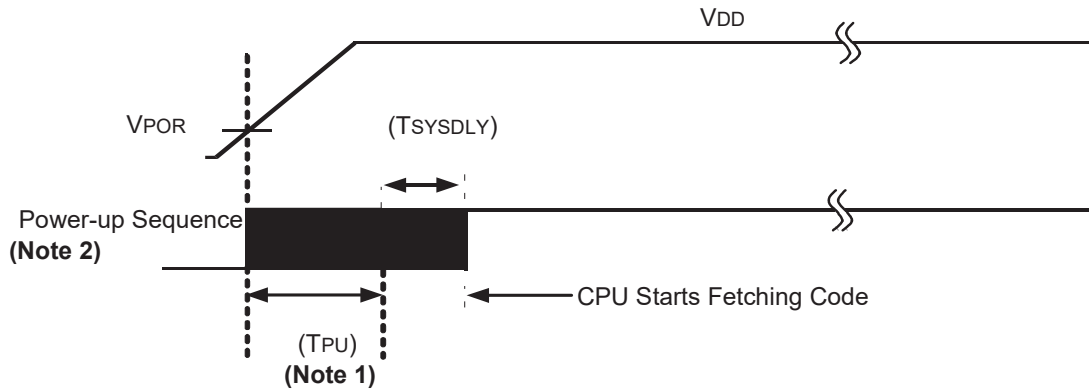

**Note:**

1. The power-up period will be extended if the power-up sequence completes before the device exits from BOR ( $V_{DD} < V_{DDMIN}$ ).
2. Includes interval voltage regulator stabilization delay.

Figure 6-4. Brown-out Reset Timing

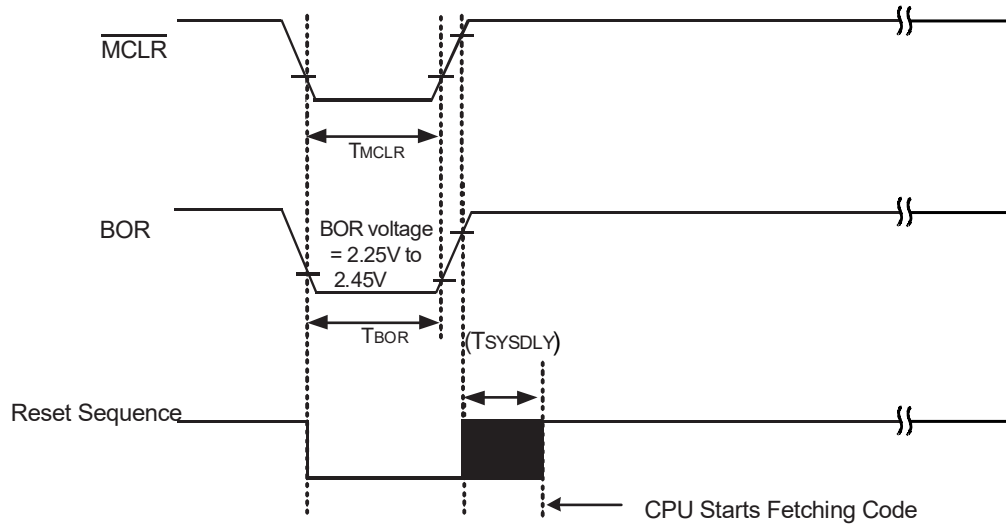

## 6.2 Power Management Unit (PMU)

### 6.2.1 Basic Connection Requirements

The device requires a nominal 3.3V supply voltage. The following pins need to be connected:

- All  $V_{DD}$  and  $V_{SS}$  pins need connection to the supply voltage and decoupling capacitors
- **$V_{CORECAP}$** : The devices' core and digital logic is designed to operate at a nominal 1.8V, which is provided by an on-chip regulator. The required core logic voltage is derived from  $V_{DD}$  and is outputted on the  $V_{CORECAP}$  pin. A low-ESR capacitor (such as tantalum) must be connected to the  $V_{CORECAP}$  pin. This helps to maintain the stability of the regulator.
- **$AV_{DD}$** : Analog voltage references for the ADC needs to be connected to the supply voltage and a decoupling capacitor
- **$V_{ANA}$** : Analog supply for GestIC analog front end must be connected to the supply voltage

Figure 6-5. Connections for  $V_{CORE}$  Regulator

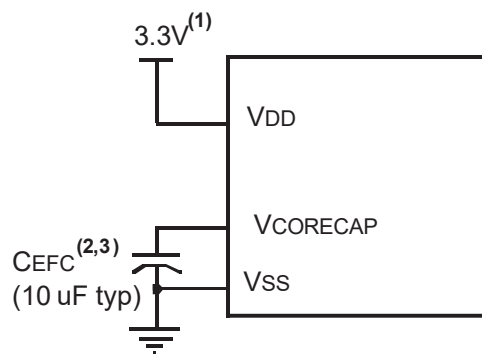

Note:

1. These are typical operating voltages.
2. It is important that the low-ESR capacitor is placed as close as possible to the  $V_{CAP}$  pin.
3. The typical voltage on the  $V_{CAP}$  is 1.8V.

### 6.2.2 Decoupling Capacitors

The use of decoupling capacitors on power supply pins, such as  $V_{DD}$ ,  $V_{SS}$ , and  $AV_{DD}$  is required.

Consider the following criteria when using decoupling capacitors:

- **Value and type of capacitor:** A value of 0.1  $\mu\text{F}$  (100 nF), 10-20V is recommended. The capacitor should be a low Equivalent Series Resistance (low-ESR) capacitor and have resonance frequency in the range of 20 MHz and higher. It is further recommended that ceramic capacitors be used.
- **Placement on the printed circuit board:** The decoupling capacitors should be placed as close to the pins as possible. It is recommended that the capacitors be placed on the same side of the board as the device. If space is constricted, the capacitor can be placed on another layer on the PCB using a via; however, ensure that the trace length from the pin to the capacitor is within 6 mm in length.
- **Handling high-frequency noise:** If the board is experiencing high-frequency noise, upward of tens of MHz, add a second ceramic-type capacitor in parallel to the above described decoupling capacitor. The value of the second capacitor can be in the range of 0.01  $\mu\text{F}$  to 0.001  $\mu\text{F}$ . Place this second capacitor next to the primary decoupling capacitor. In high-speed circuit designs, consider implementing a decade pair of capacitances as close to the power and ground pins as possible. For example, 0.1  $\mu\text{F}$  in parallel with 0.001  $\mu\text{F}$ .
- **Maximizing performance:** On the board layout from the power supply circuit, run the power and return traces to the decoupling capacitors first, and then to the device pins. This ensures that the decoupling capacitors are first in the power chain. Equally important is to keep the trace length between the capacitor and the power pins to a minimum, thereby reducing PCB track inductance.

#### Related Links

[8.5 Reference Schematic](#)

### 6.3 Clocks

The MGC3140 is embedding two internal oscillators, high speed and low speed. The High-Speed Oscillator (HSO) is factory-trimmed, achieving high accuracy.

- **High-Speed Oscillator (HSO):** The MGC3140 is clocked by an internal HSO running at 40 MHz (+/- 2%). This clock is used to generate the Tx signal, to trigger the ADC conversions and to run the SPU. During Deep Sleep mode, the HSO clock is switched off.
- **Low-Speed Oscillator (LSO):** This low-speed and ultra-low-power oscillator is typically 32 kHz (+/- 15%). It is used during power-saving modes.

### 6.4 Operation Modes

MGC3140 offers three operation modes that allow the user to balance power consumption with device functionality. In all of the modes described in this section, power saving is configured by GestIC Library messages. A summary of the operation modes, as well as their respective current consumption values are given in the table below:



**Table 6-1. Operation Modes Summary**

Mode	Entry	Exit	Comments
Processing	I <sup>2</sup> C/Approach/ $\overline{\text{MCLR}}$ /WDTR/SW Reset	GestIC <sup>®</sup> Library Message/ Non- Activity Time-out/ WDTR	Processing mode with up to five electrodes continuously running Full positioning and Gesture Recognition capabilities
Wake-up on Approach	Hand not present Time-out/GestIC <sup>®</sup> Library Message	I <sup>2</sup> C Message/ $\overline{\text{MCLR}}$ /WDTR/ Hand Detected	Scan phase with a configurable number of Rx active channels, wake-up timer is used to resume the system Approach detection capability Fast wake-up time Very low-power consumption
Deep Sleep	GestIC <sup>®</sup> Library Message	I <sup>2</sup> C Message/ $\overline{\text{MCLR}}$	SPU halted, Watchdog OFF No positioning or gesture detection Extreme low-power consumption: Needs trigger from application host to switch into Wake-up on Approach or Processing mode

**Figure 6-6. Operation Mode Flow**

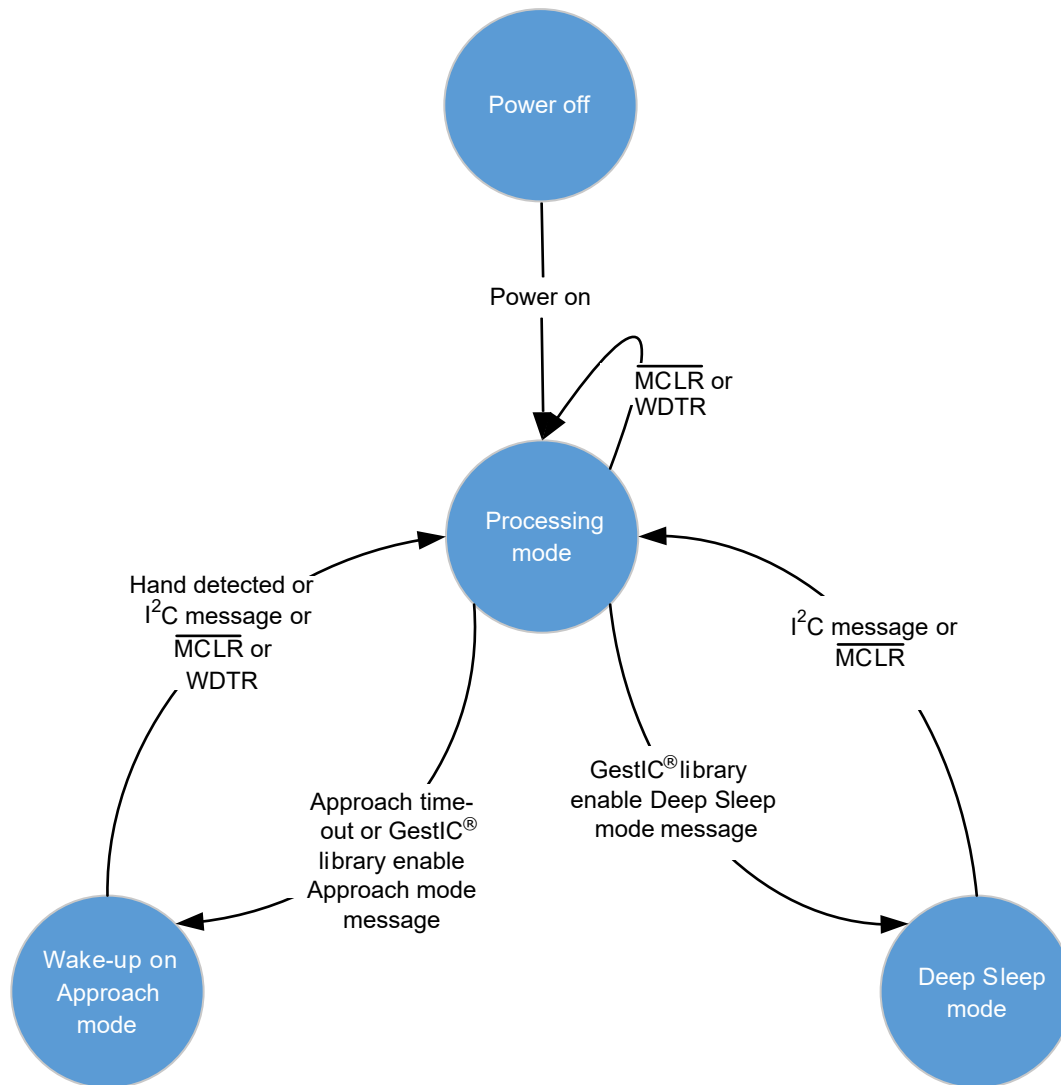

### 6.4.1 Processing Mode

In this mode, all power domains are enabled and the SPU is running continuously. All peripheral digital blocks are active. Gesture recognition and position tracking require the Processing Operation mode.

### 6.4.2 Deep Sleep Mode

The Deep Sleep mode includes the following characteristics:

- The SPU is halted
- The High-Speed Oscillator is shut down
- The Low-Speed Oscillator is running
- The Watchdog is switched off
- Host interface pins are active for wake-up

This leads to the lowest possible power consumption of MGC3140. The device will resume from Deep Sleep if one of the following events occurs:

- I<sup>2</sup>C Start bit detection
- On  $\overline{\text{MCLR}}$  Reset

The Deep Sleep mode can be enabled by GestIC Library messages.

### 6.4.3 Wake-up-on-Approach Mode

The Wake-up-on-Approach mode is a low power mode allowing an autonomous wake-up of the MGC3140 and application host. In this mode, the MGC3140 is automatically and periodically alternating between Deep Sleep and scan phases.

During the approach scan phase, the sensor will be able to detect an approach of the human hand and change to Processing mode accordingly.

The MGC3140's fast wake-up, typically below 1 ms, allows the performance of scans in very efficient periods and to maximize the Sleep phase.

Additionally, the sensor will perform periodic AFA scans in which the sensor will scan through all available Tx frequencies and select an optimal frequency depending on the signals' noise level.

The periodic wake-up sequence is triggered by a programmable wake-up timer running at the low-speed Oscillator 32 kHz frequency. The repetition rate of the scan can be adjusted via the host, affecting the sensitivity and current consumption during Wake-up-on-Approach.

The MGC3140 enters the Self Wake-up mode by a GestIC Library message or by a non-activity time-out. Non-activity means no user detection within the sensing area.

The MGC3140 will resume from Self Wake-up on one of the following events:

- Detection of a human hand approaching the sensor
- I<sup>2</sup>C Start bit detection
- On  $\overline{\text{MCLR}}$  or WDTR

### 6.4.4 Transmit Signal Generation

The Tx signal generation block provides five bandwidth limited square wave signals for the transmit electrode. The five Tx signals are combined through a resistive network to provide a single Tx signal to the Tx electrode. This provides slew control to the rising and falling Tx signal edges in order to reduce radiated emissions. Frequency hopping automatically adjusts the Tx carrier frequency choosing one of the five transmit frequencies, depending on the environmental noise conditions. GestIC Library automatically selects the lowest noise working frequency in case the sensor signal is compromised. Frequencies can be enabled/disabled via the GestIC Library.

### 6.4.5 Receive (Rx) Channels

There are five identical Rx channels that can be used for five respective receive electrodes. Four receive electrodes are required for Position Tracking and Gesture Recognition. A fifth electrode can be used for touch detection and for approach detection in Wake-up on Approach mode. Every Rx input pin is connected to its own dedicated ADC. The Rx input signal is sampled at a sampling rate equal to double the Tx frequency, providing a high and low ADC sample.

The electrodes can be connected in any order to the external electrodes. The channel assignment is then done in a parameterization step in Aurea GUI or alternatively using I<sup>2</sup>C commands.



**Important:** It is recommended to assign Rx channels 1 to 4 in most application designs, only using RX0 if a fifth Rx electrode is required.

---

### 6.4.6 Analog-to-Digital Converter (ADC)

As outlined in the previous section, each Rx channel features a dedicated ADC with a trigger derived from the internal clock. ADC samples are synchronous with twice the Tx transmit frequency.

### 6.4.7 Signal Processing Unit (SPU)

The MGC3140 features a Signal Processing Unit (SPU) to control the hardware blocks and process the advanced DSP algorithms included in the GestIC Library. It provides filtered sensor data, continuous position information and recognized gestures to the application host. The host combines the information and controls its application.

### 6.4.8 Parameters Storage

The MGC3140 provides an embedded 128 kB Flash memory which is dedicated for the GestIC Library and storage of the individual configuration parameters. These parameters have to be set according to the individual electrode design and application. The GestIC Library and parameters are loaded into MGC3140 with the provided software tools or, alternatively, via GestIC Library messages by the application host.

#### Related Links

[9. Development Support](#)

## 7. Interface Description

The MGC3140 supports an I<sup>2</sup>C interface in Slave mode. For further information on the I<sup>2</sup>C interface as well as a list of the I<sup>2</sup>C commands, see "MGC3140 - GestIC Library Interface Description User's Guide" (DS40001875).

### 7.1 Interface Address Selection

The MGC3140 interface selection pins IS1 and IS2 are used to select the MGC3140 interface.

**Table 7-1. Interface Pins**

IS2	IS1	Mode (Address)
0	0	I <sup>2</sup> C Slave Mode (Address 0x42)
1	0	Reserved

### 7.2 I<sup>2</sup>C Slave Mode

#### 7.2.1 I<sup>2</sup>C Hardware Interface

A summary of the hardware interface pins is shown below:

**Table 7-2. Interface Pins**

Pin	Function
SCL	Serial Clock to Master I <sup>2</sup> C
SDA	Serial Data to Master I <sup>2</sup> C
$\overline{\text{TS}}$	Transfer Status Line

The MGC3140 requires a dedicated Transfer Status line ( $\overline{\text{TS}}$ ). The MGC3140 (I<sup>2</sup>C Slave) uses this line to inform the host controller (I<sup>2</sup>C Master) that there is data available which can be transferred. The  $\overline{\text{TS}}$  line is electrically open-drain and requires a pull-up resistor of typically 10 k $\Omega$  from the  $\overline{\text{TS}}$  line to V<sub>DD</sub>. The  $\overline{\text{TS}}$  Idle state is high.

The MGC3140 uses an internal I<sup>2</sup>C message buffer. If after a read operation there are remaining messages in the buffer, the  $\overline{\text{TS}}$  will only go high for a short time period and then be driven low again.

**Table 7-3. Usage of  $\overline{\text{TS}}$  Line**

Device	$\overline{\text{TS}}$ Line	Status
Released (H)	High	No new pending message from the device
Asserted (L)	Low	New message from device available; Host can start reading I <sup>2</sup> C message

**Figure 7-1. Example for  $\overline{TS}$  Line Indication and Following Read Operation**

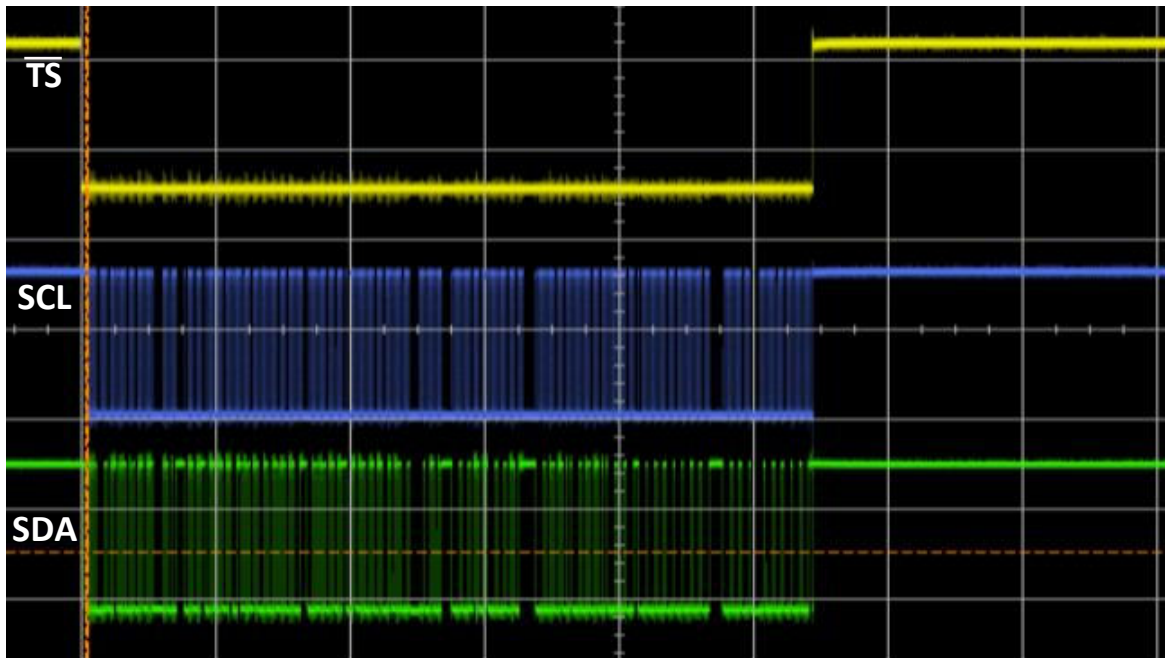

**Note:** The  $\overline{TS}$  line handling of the MGC3140 is different to MGC3x30 devices. With the MGC3140 there is no need for the host to assert the  $\overline{TS}$  line.

### 7.2.2 I<sup>2</sup>C Message Buffer

The MGC3140 has an internal FIFO I<sup>2</sup>C message buffer for a total of five messages. After a I<sup>2</sup>C message read process is started by the host, the message will be deleted from the buffer. Also if the I<sup>2</sup>C transfer of a message is read by the host and the transfer is interrupted, the message will be deleted. For further information, refer to “MGC3140 - GestIC Library Interface Description User’s Guide”(DS40001875).

### 7.2.3 I<sup>2</sup>C Addressing

The MGC3140 Device ID 7-bit address is: 0x42 (0b1000010) depending on the interface selection pin configuration. Refer to the table below:

**Table 7-4. I<sup>2</sup>C Device ID Address**

Device ID Address, 7-bit							
Address offset	A7	A6	A5	A4	A3	A2	A1
0x42	1	0	0	0	0	1	0
0x43	1	0	0	0	0	1	1

### 7.2.4 Timing Descriptions

**I<sup>2</sup>C Clock** - The I<sup>2</sup>C clock operates up to 400 kHz.

### I<sup>2</sup>C Master Read Bit Timing

Master read is to receive position data, gesture reports and command responses from the MGC3140. The timing diagram is shown below:

**Figure 7-2. I<sup>2</sup>C Master Read Bit Timing Diagram**

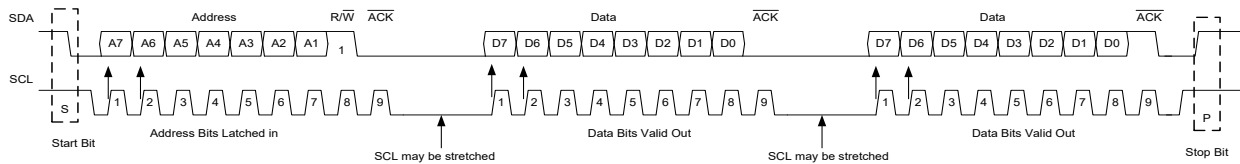

- Address bits are latched into the MGC3140 on the rising edges of SCL.
- Data bits are latched out of the MGC3140 on the rising edges of SCL.
- ACK bit:
  - MGC3140 presents the ACK bit on the ninth clock for address acknowledgment
  - I<sup>2</sup>C master presents the ACK bit on the ninth clock for data acknowledgment
- The I<sup>2</sup>C master must monitor the SCL pin prior to asserting another clock pulse, as the MGC3140 may be holding off the I<sup>2</sup>C master by stretching the clock.

### I<sup>2</sup>C Communication Steps

1. SCL and SDA lines are Idle high.
2. I<sup>2</sup>C master presents Start bit to the MGC3140 by taking SDA high-to-low, followed by taking SCL high-to-low.
3. I<sup>2</sup>C master presents 7-bit address, followed by a  $R/\bar{W} = 1$  (Read mode) bit to the MGC3140 on SDA, at the rising edge of eight master clock (SCL) cycles.
4. MGC3140 compares the received address to its Device ID. If they match, the MGC3140 acknowledges (ACK) the master sent address by presenting a low on SDA, followed by a low-high-low on SCL.
5. I<sup>2</sup>C master monitors SCL, as the MGC3140 may be clock-stretching, holding SCL low to indicate that the I<sup>2</sup>C master should wait.
6. I<sup>2</sup>C master receives eight data bits (MSB first) presented on SDA by the MGC3140, at eight sequential I<sup>2</sup>C master clock (SCL) cycles. The data is latched out on SCL falling edges to ensure it is valid during the subsequent SCL high time.
7. If data transfer is not complete, then:
  - I<sup>2</sup>C master acknowledges (ACK) reception of the eight data bits by presenting a low on SDA, followed by a low-high-low on SCL.
  - Go to Step 5.
8. If data transfer is complete, then:
  - I<sup>2</sup>C master acknowledges (ACK) reception of the eight data bits and a completed data transfer by presenting a high on SDA, followed by a low-high-low on SCL.

### I<sup>2</sup>C Master Write Bit Timing

I<sup>2</sup>C master write is to send supported commands to the MGC3140. The timing diagram is shown below:

**Figure 7-3. I<sup>2</sup>C Master Write Bit Timing Diagram**

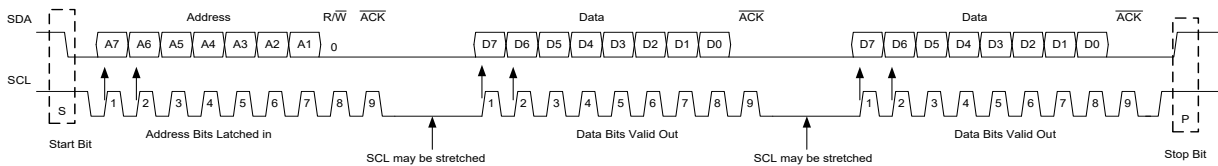

- Address bits are latched into the MGC3140 on the rising edges of SCL.
- Data bits are latched into the MGC3140 on the rising edges of SCL.
- ACK bit:
  - MGC3140 presents the ACK bit on the ninth clock for address acknowledgment
  - I<sup>2</sup>C master presents the ACK bit on the ninth clock for data acknowledgment
- The master must monitor the SCL pin prior to asserting another clock pulse, as the MGC3140 may be holding off the master by stretching the clock.

### I<sup>2</sup>C Communication Steps

1. SCL and SDA lines are Idle high.
2. I<sup>2</sup>C master presents Start bit to the MGC3140 by taking SDA high-to-low, followed by taking SCL high-to-low.
3. I<sup>2</sup>C master presents 7-bit address, followed by a R/W = 0 (Write mode) bit to the MGC3140 on SDA, at the rising edge of eight master clock (SCL) cycles.
4. MGC3140 compares the received address to its Device ID. If they match, the MGC3140 acknowledges (ACK) the I<sup>2</sup>C master sent address by presenting a low on SDA, followed by a low-high-low on SCL.
5. I<sup>2</sup>C master monitors SCL, as the MGC3140 may be clock stretching, holding SCL low to indicate the I<sup>2</sup>C master should wait.
6. I<sup>2</sup>C master presents eight data bits (MSB first) to the MGC3140 on SDA, at the rising edge of eight master clock (SCL) cycles.
7. MGC3140 acknowledges (ACK) receipt of the eight data bits by presenting a low on SDA, followed by a low-high-low on SCL.
8. If data transfer is not complete, then go to Step 5.
9. Master presents a Stop bit to the MGC3140 by taking SCL low-high, followed by taking SDA low-to-high.



**Important:** The Stop condition after an I<sup>2</sup>C data transmission is generated by the host controller (I<sup>2</sup>C master) after the data transfer is completed. Thus, it is recommended to verify the number of bytes to be read in the message header (Size field).

## 7.3 Gesture Port

The MGC3140 provides five output pins which can be used to indicate gesture events. These pins are controlled by GestIC Library to signal that an event occurred. The host does not need to monitor the I<sup>2</sup>C bus to get GestIC Library events, but only has to monitor the Gesture Port pins. This feature can be used in parallel to I<sup>2</sup>C communication.



Up to 20 event outputs can be mapped to any Gesture port (1, 2, 3, 4 or 5). To activate this feature contact Microchip support. It is also possible to map more than one event output to one Gesture port.

## 8. Application Architecture

The standard MGC3140 application architecture consists of a MGC3140 controller connected to external electrodes and an application host. For further information on the electrode design, refer to “[GestIC Design Guide](#)” (DS40001716). Details on the I<sup>2</sup>C interface can be found in “*MGC3140 - GestIC Library Interface Description User’s Guide*” (DS40001875).

### 8.1 ESD Considerations

The MGC3140 provides Electrostatic Discharge (ESD) voltage protection up to 4 kV (HBM) and Charge Device Model (CDM) 750V on corner pins; 500V on all other pins. Additional ESD countermeasures may be implemented individually to meet application-specific requirements.

### 8.2 Power Noise Considerations

MGC3140 filtering capacitors are included in the reference design schematic.

### 8.3 High-Frequency Noise Immunity

In order to suppress irradiated high-frequency signals, the five Rx channels of the chip are connected to the electrodes via serial 10 k $\Omega$  resistors, as close as possible to MGC3140. The 10 k $\Omega$  resistor and the MGC3140 input capacitance are building a low-pass filter with a corner frequency of 3 MHz. An additional ferrite bead is recommended to suppress the coupling of RF noise to the Tx channel (e.g., 600 $\Omega$  at 100 MHz).

### 8.4 RF Emission

The Tx pins are used to shape the Tx signal and reduce emission in relevant frequency bands. The slope of the Tx signal is randomized using dithering techniques while the sampling point is kept constant for further reduction of emission. In addition, a RC network on the Tx output will reduce the emission even further. For further support on reduction of RF emission, contact your local Microchip representative.

### 8.5 Reference Schematic

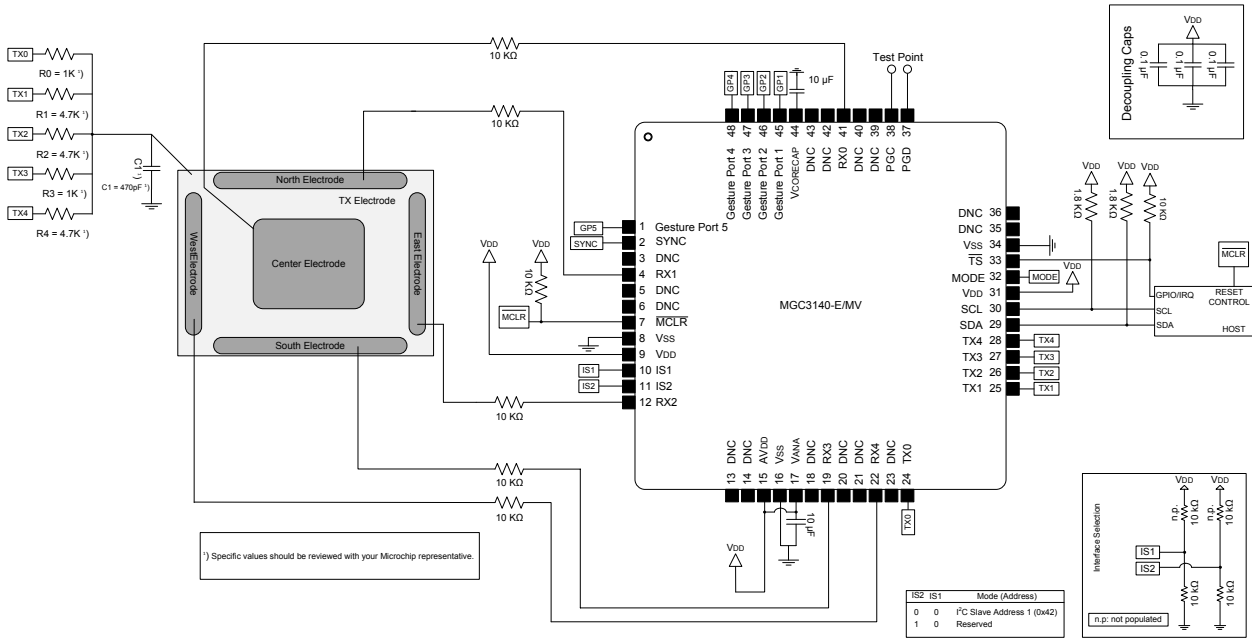

### 8.6 Layout Recommendation

This section provides a brief description of layout hints for a proper system design.

The PCB layout requirements for MGC3140 follow the general rules for a mixed signal design. In addition, there are certain requirements to be considered for the sensor signals and electrode feeding lines.

The chip should be placed as close as possible to the electrodes to keep their feeding lines as short as possible. Furthermore, it is recommended to keep MGC3140 away from electrical and thermal sources within the system.

A two layer PCB layout is sufficient to enable analog and digital signals to be separated from each other to minimize crosstalk.

The individual electrode feeding lines should be kept as far as possible apart from each other.  $V_{DD}$  lines should be routed as wide as possible.

MGC3140 requires a proper ground connection on all  $V_{SS}$  pins which can be connected together.

## 9. Development Support

Microchip provides software and hardware development tools for the MGC3140:

- Software:
  - Aurea Software Package
  - MGC3140 Linux Driver
- Schematics:
  - GestIC Hardware References

### 9.1 Aurea Software Package

The Aurea evaluation software demonstrates Microchip's GestIC technology and its features and applications. Aurea provides visualization of the MGC3140 generated data and access to GestIC Library controls and configuration parameters.

That contains the following:

- Visualization of hand position and user gestures
- Visualization of sensor data
- Real-time control of sensor features
- MGC3140 GestIC Library update
- Analog front-end parameterization
- Advanced sensor parameterization
- Logging of sensor values and storage in a log file

### 9.2 MGC3140 Linux Driver

Microchip provides a reference Linux driver which is available on: [https://github.com/MicrochipTech/linux\\_at91\\_GestIC](https://github.com/MicrochipTech/linux_at91_GestIC).

### 9.3 GestIC Hardware References

The GestIC Hardware References package contains the PCB Layouts (Gerber files) for the MGC development kits (Emerald, Hillstar and Woodstar) and a collection of electrode reference designs fitting all kits. In addition, the package includes designs, parameter files and host code of various demonstrators which represent complete systems for embedded or PC-based applications. The GestIC Hardware Reference package can be downloaded from Microchip's website via [www.microchip.com/GestICResources](http://www.microchip.com/GestICResources).

### 9.4 Evaluation Kits

For the complete list of demonstration, development and evaluation kits, refer to the Microchip website: [www.microchip.com/wwwproducts/en/mgc3140](http://www.microchip.com/wwwproducts/en/mgc3140).

## 10. Electrical Specifications

### 10.1 Absolute Maximum Ratings<sup>(†)</sup>

Parameter	Rating
Ambient temperature	-40°C to +125°C
Storage temperature	-65°C to +150°C
Voltage on V <sub>DD</sub> with respect to V <sub>SS</sub>	4V
Voltage on non I <sup>2</sup> C pins with respect to V <sub>SS</sub>	-0.3V to +3.6V
Voltage on I <sup>2</sup> C pins relative to V <sub>SS</sub>	-0.3V to +5.5V



**Notice:** (†) Stresses above those listed under “*Absolute Maximum Ratings*” may cause permanent damage to the device. This is a stress rating only and functional operation of the device at those or any other conditions above those indicated in the operation listings of this specification is not implied. Exposure above maximum rating conditions for extended periods may affect device reliability.



**Notice:** (†) This device is sensitive to ESD damage and must be handled appropriately. Failure to properly handle and protect the device in an application may cause partial to complete failure of the device.

### 10.2 Recommended Operating Conditions

Parameter	Rating
Operating temperature	-40°C to +125°C
Storage temperature	-65°C to +150°C
V <sub>DD</sub>	3.3V ± 5%
V <sub>ANA</sub>	3.3V ± 5%
A <sub>VDD</sub>	3.3V ± 5%

### 10.3 I/O Characteristics

DC Input Characteristics			Operating temperature: -40°C ≤ TA ≤ 125°C			
Characteristic	Symbol	Pin Function	Min	Max	Units	Conditions
Input low voltage	V <sub>IL</sub>	Rx pins	V <sub>SS</sub>	0.2 V <sub>DD</sub>	V	
		SDA, SCL	V <sub>SS</sub>	0.3 V <sub>DD</sub>	V	
Input high voltage	V <sub>IH</sub>	Rx pins	0.65 V <sub>DD</sub>	V <sub>DD</sub>	V	
		SDA, SCL	0.65 V <sub>DD</sub>	5.5	V	

DC Input Characteristics			Operating temperature: $-40^{\circ}\text{C} \leq T_A \leq 125^{\circ}\text{C}$			
Characteristic	Symbol	Pin Function	Min	Max	Units	Conditions
Input leakage current	$I_{IL}$	Rx pins		$\pm 1$	$\mu\text{A}$	$V_{SS} \leq V_{pin} \leq V_{DD}$
		MCLR		$\pm 1$	$\mu\text{A}$	$V_{SS} \leq V_{pin} \leq V_{DD}$

**Note:** Parameters are characterized, but not tested.

DC Output Characteristics			Operating temperature: $-40^{\circ}\text{C} \leq T_A \leq 125^{\circ}\text{C}$			
Characteristic	Symbol	Pin Function	Min	Max	Units	Conditions
Output low voltage	$V_{IL}$	Tx, SDA, SCL, SYNC		0.4	V	$I_{OL} \leq 10 \text{ mA } V_{DD} = 3.3\text{V}$
Output high voltage	$V_{IH}$	Tx, SDA, SCL, SYNC	1.5 <sup>(1)</sup>		V	$I_{OH} \geq -14 \text{ mA } V_{DD} = 3.3\text{V}$
			2.0 <sup>(1)</sup>		V	$I_{OH} \geq -12 \text{ mA } V_{DD} = 3.3\text{V}$
			2.4 <sup>(1)</sup>		$\mu\text{A}$	$I_{OH} \geq -10 \text{ mA } V_{DD} = 3.3\text{V}$
			3.0 <sup>(1)</sup>		$\mu\text{A}$	$I_{OH} \geq -7 \text{ mA } V_{DD} = 3.3\text{V}$

**Note:**

- Parameters are characterized, but not tested.

## 10.4 Current Consumption

Operating mode	Current Consumption mA
	Typical
Processing mode	29
Approach mode	0.23-2.4 <sup>(1)</sup>
Deep Sleep mode	0.085

**Note:**

- Approach mode current consumption is dependent on the Approach mode scan time. Figure 10-1 below shows the variation of current consumption with scan period.

**10.4.1 Approach scan current consumption**

**Figure 10-1. MGC3140 Power Consumption Vs Approach Scan Period**

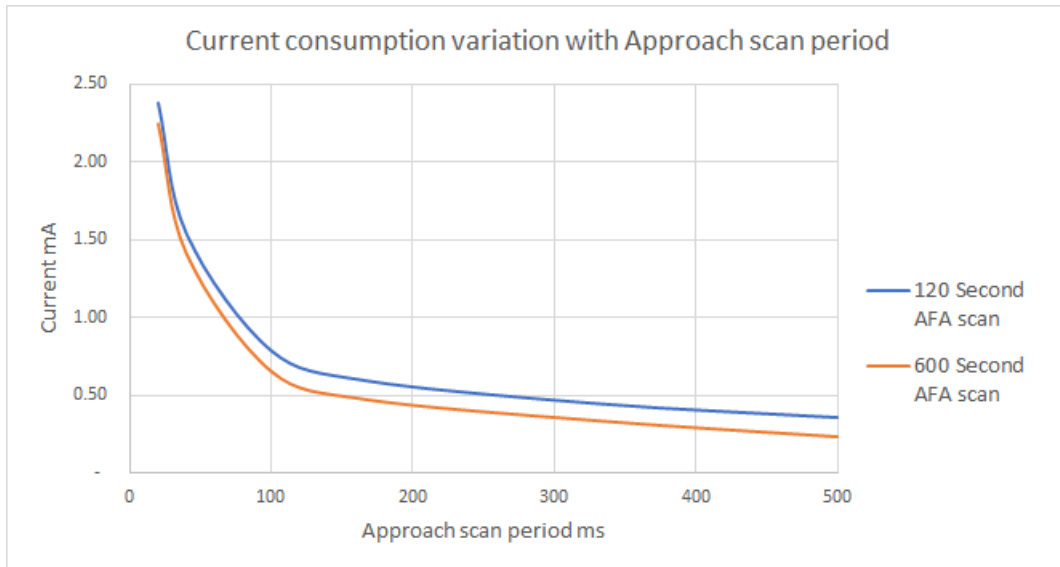

**10.5 Timing Characteristics**

**10.5.1 Power-on and Reset Timing**

**Table 10-1. Power-on and Reset Parameters**

		Operating temperature: $-40^{\circ}\text{C} \leq T_A \leq 125^{\circ}\text{C}$			
Characteristic <sup>(1)</sup>	Parameter Symbol	Min	Typical <sup>(2)</sup>	Max	Units
Power-up period:					
Internal voltage regulator enabled	TPU	-	400	600	us
System delay period:					
Time required to reload device configuration fuses plus clock delay before first instruction is fetched	TSYSDLY	-	1.2	-	us
MCLR minimum pulse width	TMCLR	2	-	-	us
BOR pulse width	TBOR	-	1	-	us

**Note:**

1. These parameters are characterized, but not tested in manufacture.
2. Data in Typical column is at 3.3V, 25°C, unless otherwise stated.

**Figure 10-2. Power-On Timings**

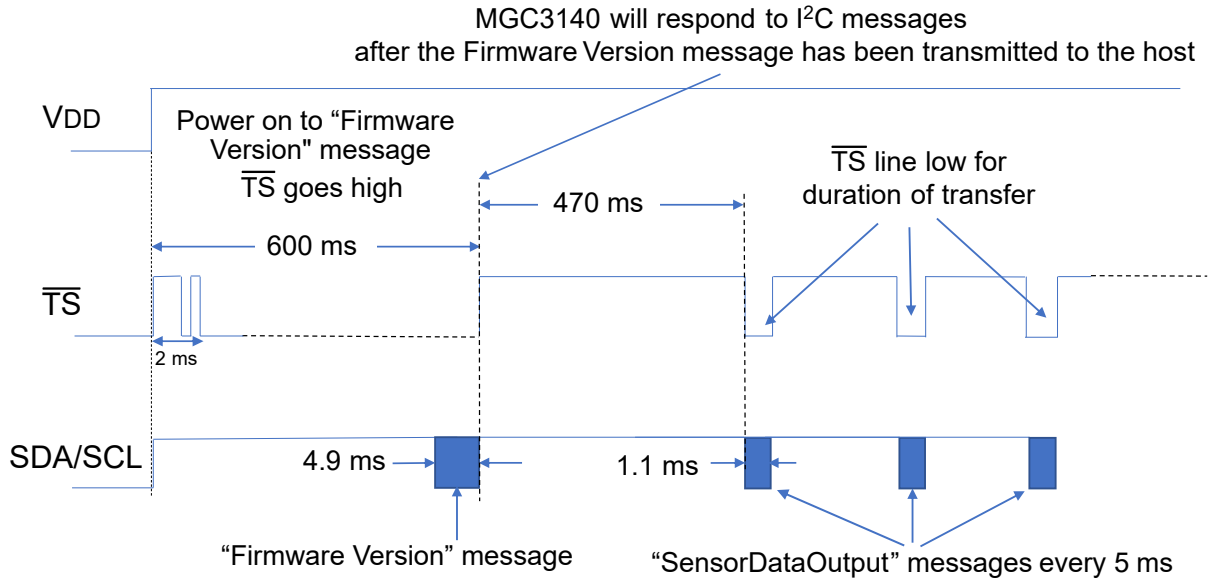

**Figure 10-3. Reset Timings**

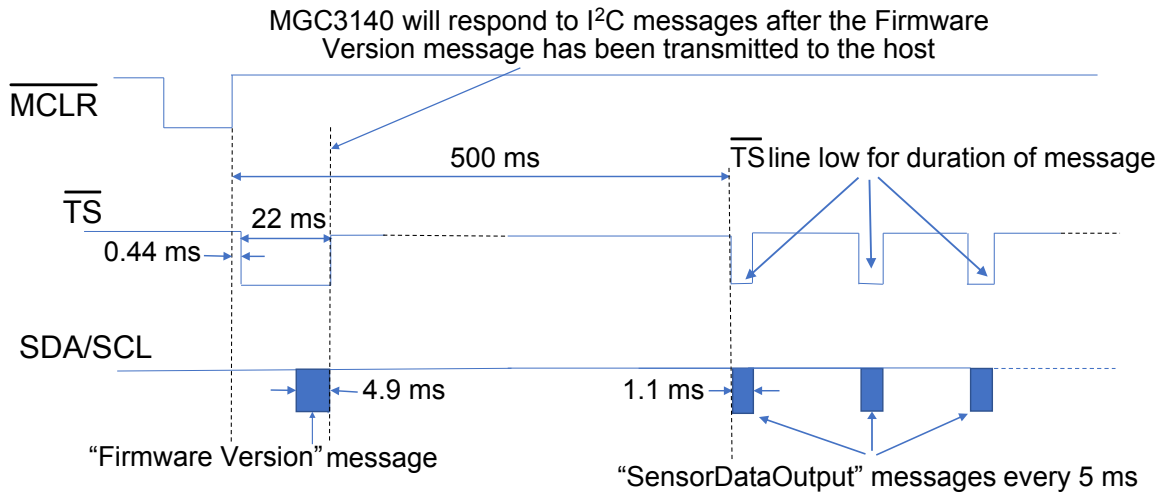



## 11. Packaging Information

### Package Marking Information

Rev. 30-009000A  
5/17/2017

<b>Legend:</b>	XX...X	Customer-specific information or Microchip part number
	Y	Year code (last digit of calendar year)
	YY	Year code (last 2 digits of calendar year)
	WW	Week code (week of January 1 is week '01')
	NNN	Alphanumeric traceability code
	(e3)	b-free JEDEC <sup>®</sup> designator for Matte Tin (Sn)
	*	This package is Pb-free. The Pb-free JEDEC designator ((e3)) can be found on the outer packaging for this package.

**Note:** In the event the full Microchip part number cannot be marked on one line, it will be carried over to the next line, thus limiting the number of available characters for customer-specific information.

Rev. 30-009048A  
3/04/2017

48-Lead UQFN (6x6x0.5 mm)

Example

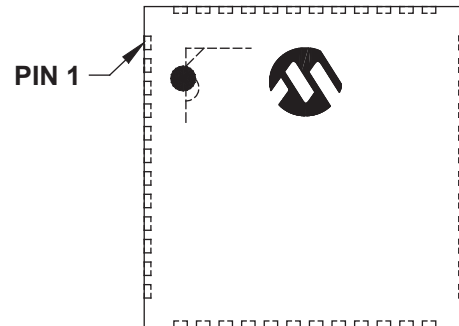
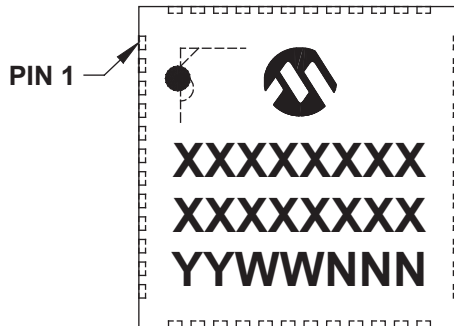

### 11.1 Package Details

The following sections give the technical details of the packages.

**48-Lead Plastic Ultra Thin Quad Flat, No Lead Package (MV) – 6x6x0.5 mm Body [UQFN]**

**Note:** For the most current package drawings, please see the Microchip Packaging Specification located at <http://www.microchip.com/packaging>

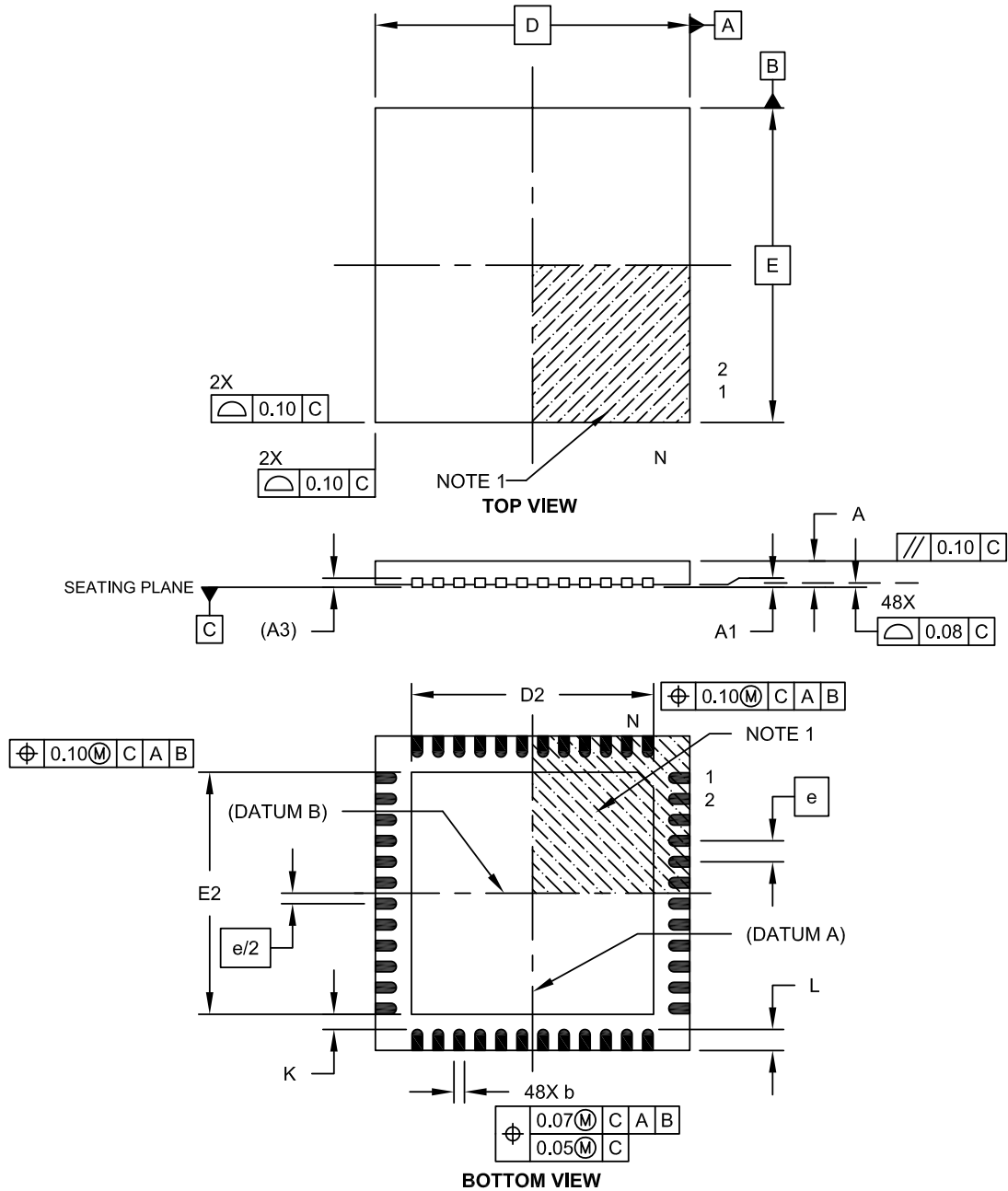

Microchip Technology Drawing C04-153A Sheet 1 of 2

**48-Lead Plastic Ultra Thin Quad Flat, No Lead Package (MV) – 6x6x0.5 mm Body [UQFN]**

**Note:** For the most current package drawings, please see the Microchip Packaging Specification located at <http://www.microchip.com/packaging>

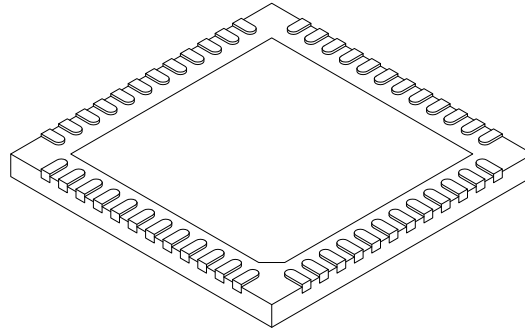

Dimension Limits	Units	MILLIMETERS		
		MIN	NOM	MAX
Number of Pins	N	48		
Pitch	e	0.40 BSC		
Overall Height	A	0.45	0.50	0.55
Standoff	A1	0.00	0.02	0.05
Contact Thickness	A3	0.127 REF		
Overall Width	E	6.00 BSC		
Exposed Pad Width	E2	4.45	4.60	4.75
Overall Length	D	6.00 BSC		
Exposed Pad Length	D2	4.45	4.60	4.75
Contact Width	b	0.15	0.20	0.25
Contact Length	L	0.30	0.40	0.50
Contact-to-Exposed Pad	K	0.20	-	-

**Notes:**

1. Pin 1 visual index feature may vary, but must be located within the hatched area.
2. Package is saw singulated.
3. Dimensioning and tolerancing per ASME Y14.5M.  
 BSC: Basic Dimension. Theoretically exact value shown without tolerances.  
 REF: Reference Dimension, usually without tolerance, for information purposes only.

Microchip Technology Drawing C04-153A Sheet 2 of 2

48-Lead Ultra Thin Plastic Quad Flat, No Lead Package (MV) - 6x6 mm Body [UQFN]  
With 0.40 mm Contact Length

**Note:** For the most current package drawings, please see the Microchip Packaging Specification located at <http://www.microchip.com/packaging>

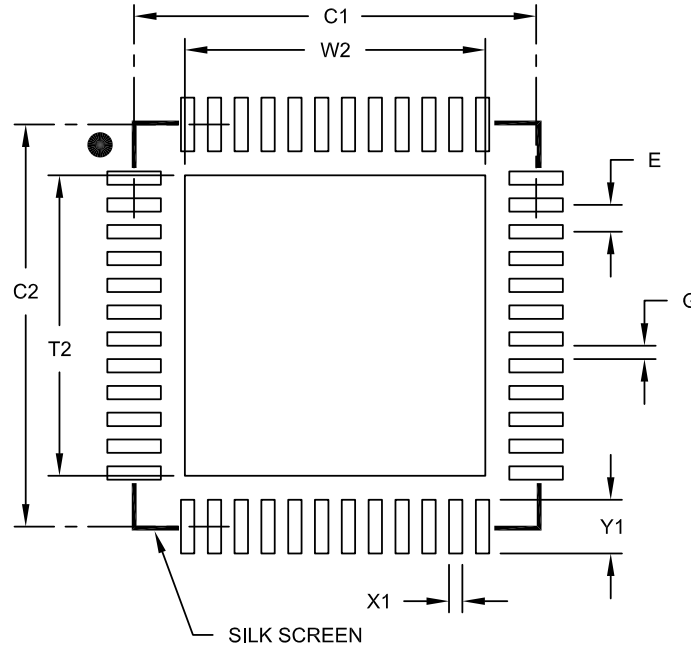

RECOMMENDED LAND PATTERN

Dimension Limits	Units	MILLIMETERS		
		MIN	NOM	MAX
Contact Pitch	E	0.40 BSC		
Optional Center Pad Width	W2			4.45
Optional Center Pad Length	T2			4.45
Contact Pad Spacing	C1		6.00	
Contact Pad Spacing	C2		6.00	
Contact Pad Width (X28)	X1			0.20
Contact Pad Length (X28)	Y1			0.80
Distance Between Pads	G	0.20		

**Notes:**

- Dimensioning and tolerancing per ASME Y14.5M  
BSC: Basic Dimension. Theoretically exact value shown without tolerances.

Microchip Technology Drawing No. C04-2153A

## The Microchip Web Site

---

Microchip provides online support via our web site at <http://www.microchip.com/>. This web site is used as a means to make files and information easily available to customers. Accessible by using your favorite Internet browser, the web site contains the following information:

- **Product Support** – Data sheets and errata, application notes and sample programs, design resources, user's guides and hardware support documents, latest software releases and archived software
- **General Technical Support** – Frequently Asked Questions (FAQ), technical support requests, online discussion groups, Microchip consultant program member listing
- **Business of Microchip** – Product selector and ordering guides, latest Microchip press releases, listing of seminars and events, listings of Microchip sales offices, distributors and factory representatives

## Customer Change Notification Service

---

Microchip's customer notification service helps keep customers current on Microchip products. Subscribers will receive e-mail notification whenever there are changes, updates, revisions or errata related to a specified product family or development tool of interest.

To register, access the Microchip web site at <http://www.microchip.com/>. Under "Support", click on "Customer Change Notification" and follow the registration instructions.

## Customer Support

---

Users of Microchip products can receive assistance through several channels:

- Distributor or Representative
- Local Sales Office
- Field Application Engineer (FAE)
- Technical Support

Customers should contact their distributor, representative or Field Application Engineer (FAE) for support. Local sales offices are also available to help customers. A listing of sales offices and locations is included in the back of this document.

Technical support is available through the web site at: <http://www.microchip.com/support>

## Product Identification System

To order or obtain information, e.g., on pricing or delivery, refer to the factory or the listed sales office.

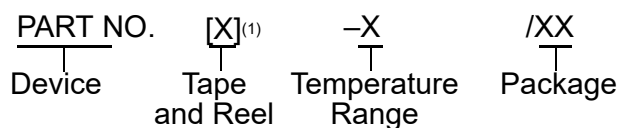

<b>Device:</b>	MGC3140	
<b>Tape &amp; Reel Option:</b>	Blank	= Tube
	T	= Tape & Reel
<b>Temperature Range:</b>	I	= -40°C to +85°C (Industrial)
	E	= -40°C to +125°C (Extended)
<b>Package</b>	MV	= 48-lead UQFN 6x6x0.5mm
<b>Pattern</b>	QTP, SQTP, Code or Special Requirements (blank otherwise)	

Orderable Part Number	Firmware Revision	Industrial/ Automotive	Description
MGC3140-E/MV (supplied in tubes)	3.0.04	Industrial	48-pin UQFN48 6x6x0.5 RoHS compliant
MGC3140-I/MV (supplied in tubes)		Industrial	
MGC3140T-E/MV (supplied in tape and reel)		Industrial	
MGC3140T-I/MV (supplied in tape and reel)		Industrial	
MGC3140-E/MVVAO (supplied in tubes)		Automotive	48-pin UQFN48 6x6x0.5 RoHS compliant
MGC3140-I/MVVAO (supplied in tubes)		Automotive	
MGC3140T-E/MVVAO (supplied in tape and reel)		Automotive	
MGC3140T-I/MVVAO (supplied in tape and reel)		Automotive	

Examples:

- MGC3140-E/MV: Extended temperature, UQFN package.
- MGC3140-I/MV: Industrial temperature, UQFN package

**Note:**

1. Tape and Reel identifier only appears in the catalog part number description. This identifier is used for ordering purposes and is not printed on the device package. Check with your Microchip Sales Office for package availability with the Tape and Reel option.

---

## Microchip Devices Code Protection Feature

---

Note the following details of the code protection feature on Microchip devices:

- Microchip products meet the specification contained in their particular Microchip Data Sheet.
- Microchip believes that its family of products is one of the most secure families of its kind on the market today, when used in the intended manner and under normal conditions.
- There are dishonest and possibly illegal methods used to breach the code protection feature. All of these methods, to our knowledge, require using the Microchip products in a manner outside the operating specifications contained in Microchip's Data Sheets. Most likely, the person doing so is engaged in theft of intellectual property.
- Microchip is willing to work with the customer who is concerned about the integrity of their code.
- Neither Microchip nor any other semiconductor manufacturer can guarantee the security of their code. Code protection does not mean that we are guaranteeing the product as "unbreakable."

Code protection is constantly evolving. We at Microchip are committed to continuously improving the code protection features of our products. Attempts to break Microchip's code protection feature may be a violation of the Digital Millennium Copyright Act. If such acts allow unauthorized access to your software or other copyrighted work, you may have a right to sue for relief under that Act.

---

## Legal Notice

---

Information contained in this publication regarding device applications and the like is provided only for your convenience and may be superseded by updates. It is your responsibility to ensure that your application meets with your specifications. MICROCHIP MAKES NO REPRESENTATIONS OR WARRANTIES OF ANY KIND WHETHER EXPRESS OR IMPLIED, WRITTEN OR ORAL, STATUTORY OR OTHERWISE, RELATED TO THE INFORMATION, INCLUDING BUT NOT LIMITED TO ITS CONDITION, QUALITY, PERFORMANCE, MERCHANTABILITY OR FITNESS FOR PURPOSE. Microchip disclaims all liability arising from this information and its use. Use of Microchip devices in life support and/or safety applications is entirely at the buyer's risk, and the buyer agrees to defend, indemnify and hold harmless Microchip from any and all damages, claims, suits, or expenses resulting from such use. No licenses are conveyed, implicitly or otherwise, under any Microchip intellectual property rights unless otherwise stated.

---

## Trademarks

---

The Microchip name and logo, the Microchip logo, AnyRate, AVR, AVR logo, AVR Freaks, BeaconThings, BitCloud, CryptoMemory, CryptoRF, dsPIC, FlashFlex, flexPWR, Helder, JukeBlox, KeeLoq, KeeLoq logo, Kleer, LANCheck, LINK MD, maXStylus, maXTouch, MediaLB, megaAVR, MOST, MOST logo, MPLAB, OptoLyzer, PIC, picoPower, PICSTART, PIC32 logo, Prochip Designer, QTouch, RightTouch, SAM-BA, SpyNIC, SST, SST Logo, SuperFlash, tinyAVR, UNI/O, and XMEGA are registered trademarks of Microchip Technology Incorporated in the U.S.A. and other countries.

ClockWorks, The Embedded Control Solutions Company, EtherSynch, Hyper Speed Control, HyperLight Load, IntelliMOS, mTouch, Precision Edge, and Quiet-Wire are registered trademarks of Microchip Technology Incorporated in the U.S.A.

Adjacent Key Suppression, AKS, Analog-for-the-Digital Age, Any Capacitor, AnyIn, AnyOut, BodyCom, chipKIT, chipKIT logo, CodeGuard, CryptoAuthentication, CryptoCompanion, CryptoController, dsPICDEM, dsPICDEM.net, Dynamic Average Matching, DAM, ECAN, EtherGREEN, In-Circuit Serial Programming, ICSP, Inter-Chip Connectivity, JitterBlocker, KleerNet, KleerNet logo, Mindi, MiWi, motorBench, MPASM, MPF, MPLAB Certified logo, MPLIB, MPLINK, MultiTRAK, NetDetach, Omniscient Code Generation, PICDEM, PICDEM.net, PICkit, PICtail, PureSilicon, QMatrix, RightTouch logo, REAL ICE, Ripple Blocker, SAM-ICE, Serial Quad I/O, SMART-I.S., SQI, SuperSwitcher, SuperSwitcher II, Total Endurance, TSHARC, USBCheck, VariSense, ViewSpan, WiperLock, Wireless DNA, and ZENA are trademarks of Microchip Technology Incorporated in the U.S.A. and other countries.

SQTP is a service mark of Microchip Technology Incorporated in the U.S.A.

Silicon Storage Technology is a registered trademark of Microchip Technology Inc. in other countries.

GestIC is a registered trademark of Microchip Technology Germany II GmbH & Co. KG, a subsidiary of Microchip Technology Inc., in other countries.

All other trademarks mentioned herein are property of their respective companies.

© 2018, Microchip Technology Incorporated, Printed in the U.S.A., All Rights Reserved.

ISBN: 978-1-5224-2982-1

## **Quality Management System Certified by DNV**

---

### **ISO/TS 16949**

Microchip received ISO/TS-16949:2009 certification for its worldwide headquarters, design and wafer fabrication facilities in Chandler and Tempe, Arizona; Gresham, Oregon and design centers in California and India. The Company's quality system processes and procedures are for its PIC<sup>®</sup> MCUs and dsPIC<sup>®</sup> DSCs, KEELOQ<sup>®</sup> code hopping devices, Serial EEPROMs, microperipherals, nonvolatile memory and analog products. In addition, Microchip's quality system for the design and manufacture of development systems is ISO 9001:2000 certified.



## Worldwide Sales and Service

AMERICAS	ASIA/PACIFIC	ASIA/PACIFIC	EUROPE
<p><b>Corporate Office</b> 2355 West Chandler Blvd. Chandler, AZ 85224-6199 Tel: 480-792-7200 Fax: 480-792-7277 Technical Support: <a href="http://www.microchip.com/support">http://www.microchip.com/support</a> Web Address: <a href="http://www.microchip.com">www.microchip.com</a></p> <p><b>Atlanta</b> Duluth, GA Tel: 678-957-9614 Fax: 678-957-1455</p> <p><b>Austin, TX</b> Tel: 512-257-3370</p> <p><b>Boston</b> Westborough, MA Tel: 774-760-0087 Fax: 774-760-0088</p> <p><b>Chicago</b> Itasca, IL Tel: 630-285-0071 Fax: 630-285-0075</p> <p><b>Dallas</b> Addison, TX Tel: 972-818-7423 Fax: 972-818-2924</p> <p><b>Detroit</b> Novi, MI Tel: 248-848-4000</p> <p><b>Houston, TX</b> Tel: 281-894-5983</p> <p><b>Indianapolis</b> Noblesville, IN Tel: 317-773-8323 Fax: 317-773-5453 Tel: 317-536-2380</p> <p><b>Los Angeles</b> Mission Viejo, CA Tel: 949-462-9523 Fax: 949-462-9608 Tel: 951-273-7800</p> <p><b>Raleigh, NC</b> Tel: 919-844-7510</p> <p><b>New York, NY</b> Tel: 631-435-6000</p> <p><b>San Jose, CA</b> Tel: 408-735-9110 Tel: 408-436-4270</p> <p><b>Canada - Toronto</b> Tel: 905-695-1980 Fax: 905-695-2078</p>	<p><b>Australia - Sydney</b> Tel: 61-2-9868-6733</p> <p><b>China - Beijing</b> Tel: 86-10-8569-7000</p> <p><b>China - Chengdu</b> Tel: 86-28-8665-5511</p> <p><b>China - Chongqing</b> Tel: 86-23-8980-9588</p> <p><b>China - Dongguan</b> Tel: 86-769-8702-9880</p> <p><b>China - Guangzhou</b> Tel: 86-20-8755-8029</p> <p><b>China - Hangzhou</b> Tel: 86-571-8792-8115</p> <p><b>China - Hong Kong SAR</b> Tel: 852-2943-5100</p> <p><b>China - Nanjing</b> Tel: 86-25-8473-2460</p> <p><b>China - Qingdao</b> Tel: 86-532-8502-7355</p> <p><b>China - Shanghai</b> Tel: 86-21-3326-8000</p> <p><b>China - Shenyang</b> Tel: 86-24-2334-2829</p> <p><b>China - Shenzhen</b> Tel: 86-755-8864-2200</p> <p><b>China - Suzhou</b> Tel: 86-186-6233-1526</p> <p><b>China - Wuhan</b> Tel: 86-27-5980-5300</p> <p><b>China - Xian</b> Tel: 86-29-8833-7252</p> <p><b>China - Xiamen</b> Tel: 86-592-2388138</p> <p><b>China - Zhuhai</b> Tel: 86-756-3210040</p>	<p><b>India - Bangalore</b> Tel: 91-80-3090-4444</p> <p><b>India - New Delhi</b> Tel: 91-11-4160-8631</p> <p><b>India - Pune</b> Tel: 91-20-4121-0141</p> <p><b>Japan - Osaka</b> Tel: 81-6-6152-7160</p> <p><b>Japan - Tokyo</b> Tel: 81-3-6880-3770</p> <p><b>Korea - Daegu</b> Tel: 82-53-744-4301</p> <p><b>Korea - Seoul</b> Tel: 82-2-554-7200</p> <p><b>Malaysia - Kuala Lumpur</b> Tel: 60-3-7651-7906</p> <p><b>Malaysia - Penang</b> Tel: 60-4-227-8870</p> <p><b>Philippines - Manila</b> Tel: 63-2-634-9065</p> <p><b>Singapore</b> Tel: 65-6334-8870</p> <p><b>Taiwan - Hsin Chu</b> Tel: 886-3-577-8366</p> <p><b>Taiwan - Kaohsiung</b> Tel: 886-7-213-7830</p> <p><b>Taiwan - Taipei</b> Tel: 886-2-2508-8600</p> <p><b>Thailand - Bangkok</b> Tel: 66-2-694-1351</p> <p><b>Vietnam - Ho Chi Minh</b> Tel: 84-28-5448-2100</p>	<p><b>Austria - Wels</b> Tel: 43-7242-2244-39 Fax: 43-7242-2244-393</p> <p><b>Denmark - Copenhagen</b> Tel: 45-4450-2828 Fax: 45-4485-2829</p> <p><b>Finland - Espoo</b> Tel: 358-9-4520-820</p> <p><b>France - Paris</b> Tel: 33-1-69-53-63-20 Fax: 33-1-69-30-90-79</p> <p><b>Germany - Garching</b> Tel: 49-8931-9700</p> <p><b>Germany - Haan</b> Tel: 49-2129-3766400</p> <p><b>Germany - Heilbronn</b> Tel: 49-7131-67-3636</p> <p><b>Germany - Karlsruhe</b> Tel: 49-721-625370</p> <p><b>Germany - Munich</b> Tel: 49-89-627-144-0 Fax: 49-89-627-144-44</p> <p><b>Germany - Rosenheim</b> Tel: 49-8031-354-560</p> <p><b>Israel - Ra'anana</b> Tel: 972-9-744-7705</p> <p><b>Italy - Milan</b> Tel: 39-0331-742611 Fax: 39-0331-466781</p> <p><b>Italy - Padova</b> Tel: 39-049-7625286</p> <p><b>Netherlands - Drunen</b> Tel: 31-416-690399 Fax: 31-416-690340</p> <p><b>Norway - Trondheim</b> Tel: 47-7289-7561</p> <p><b>Poland - Warsaw</b> Tel: 48-22-3325737</p> <p><b>Romania - Bucharest</b> Tel: 40-21-407-87-50</p> <p><b>Spain - Madrid</b> Tel: 34-91-708-08-90 Fax: 34-91-708-08-91</p> <p><b>Sweden - Gothenberg</b> Tel: 46-31-704-60-40</p> <p><b>Sweden - Stockholm</b> Tel: 46-8-5090-4654</p> <p><b>UK - Wokingham</b> Tel: 44-118-921-5800 Fax: 44-118-921-5820</p>

# X-ON Electronics

Largest Supplier of Electrical and Electronic Components

*Click to view similar products for [LED Lighting Drivers](#) category:*

*Click to view products by [Microchip](#) manufacturer:*

Other Similar products are found below :

[LV5235V-MPB-H](#) [MB39C602PNF-G-JNEFE1](#) [FAN5702UMP30X](#) [MIC2871YMK-T5](#) [MP1518DJ-LF-P](#) [MP1528DK-LF-Z](#) [MP3202DG-LF-P](#)  
[MP3304BDD-LF-P](#) [MP3306EG-LF-P](#) [MP3398AGY](#) [MP4033GK](#) [AL1676-10BS7-13](#) [AL1676-20AS7-13](#) [MX877RTR](#) [NCL30085BDR2G](#) [ICL8201](#)  
[IS31BL3506B-TTLS2-TR](#) [PAM2808BLBR](#) [PAM2841GR](#) [A8519KLPTR-T](#) [FAN5702UMP20X](#) [AL3157F-7](#) [AL8807BQMP-13](#) [AP3031KTR-AG1](#)  
[LV52204MTTBG](#) [TLD1120EL](#) [TLD1125EL](#) [MP2488DN-LF](#) [MP24893DQ-LF-P](#) [MP24894GJ-P](#) [MP24895GJ-P](#) [MP3308DL-LF-Z](#) [MP3393EF-LF](#)  
[MP3394SGF](#) [MP3802DQ-LF-P](#) [MP4008GS](#) [MP4031GS](#) [MP4032-1GS](#) [MP4034GS](#) [MP46885DN-LF](#) [SLG7NT4082V](#) [SLG7NT4082VTR](#)  
[PCA9955BTWQ900J](#) [TLD5095EL](#) [LED6001TR](#) [LDS8845-002-T2](#) [LED7707TR](#) [STP4CMPQTR](#) [BD1604MVV-E2](#) [MAX16832CASAT](#)