



K430WQC-V3-FF

Product

Standard LCD Module
480 x RGB x 272 Dots
4.3 inch 16.7M colors TFT display
Wide temperature
With white LED backlight
With touch screen



CONTENTS

Page No.

| | | |
|-----|-------------------------------------|----|
| 1. | DOCUMENT REVISION HISTORY | 3 |
| 2. | GENERAL DESCRIPTION | 4 |
| 3. | MECHANICAL SPECIFICATIONS | 4 |
| 4. | INTERFACE SIGNALS | 6 |
| 5. | ABSOLUTE MAXIMUM RATINGS | 7 |
| 6. | ELECTRICAL SPECIFICATIONS | 7 |
| 7. | OPTICAL CHARACTERISTICS | 8 |
| 8. | AC CHARACTERISTIC AND SIGNAL TIMING | 11 |
| 9. | RELIABILITY TEST ITEM | 11 |
| 10. | SUGGESTIONS FOR USING LCD MODULES | 12 |



1. Document revision history :

| DOCUMENT REVISION | DATE | DESCRIPTION | PREPARED BY | APPROVED BY |
|-------------------|------------|----------------|-------------|-------------|
| 01 | 2011.05.30 | First Release. | XH Dai | |



2. General Description

- 4.3”(diagonal), 480 x RGB x 272 dots, 16.7M colors, Normal white TN, TFT LCD module.
- Viewing Direction: 6 o’clock.
- Controller: SSD1963 graphic controller/driver.
- 8080 system 8-bit or 16-bit
- With internal voltage booster.
- Logic voltage: 3.3V (typ.).

3. Mechanical Specifications

The mechanical detail is shown in Fig. 1 and summarized in Table 1 below.

Table 1

| Parameter | | Specifications | Unit |
|--------------------------|---------------------|---|-------|
| Outline dimensions | | 105.5(W) x 67.2(H) x 9.6(D) (Exclude FPC, cables of backlight) | mm |
| Color TFT 480xRGBx272 | TP aiew area | 96.70(W) x 55.50(H) | mm |
| | TP view area | 98.70(W)x57.50(H) | mm |
| | LCD active area | 95.04(W) x 53.856(H) | mm |
| | Display format | 480 x RGB x 272 | dots |
| | Color configuration | RGB Side-stripes | - |
| | Dot size | 0.198 (W) x 0.198(RGB) | mm |
| Weight | | TBD | grams |

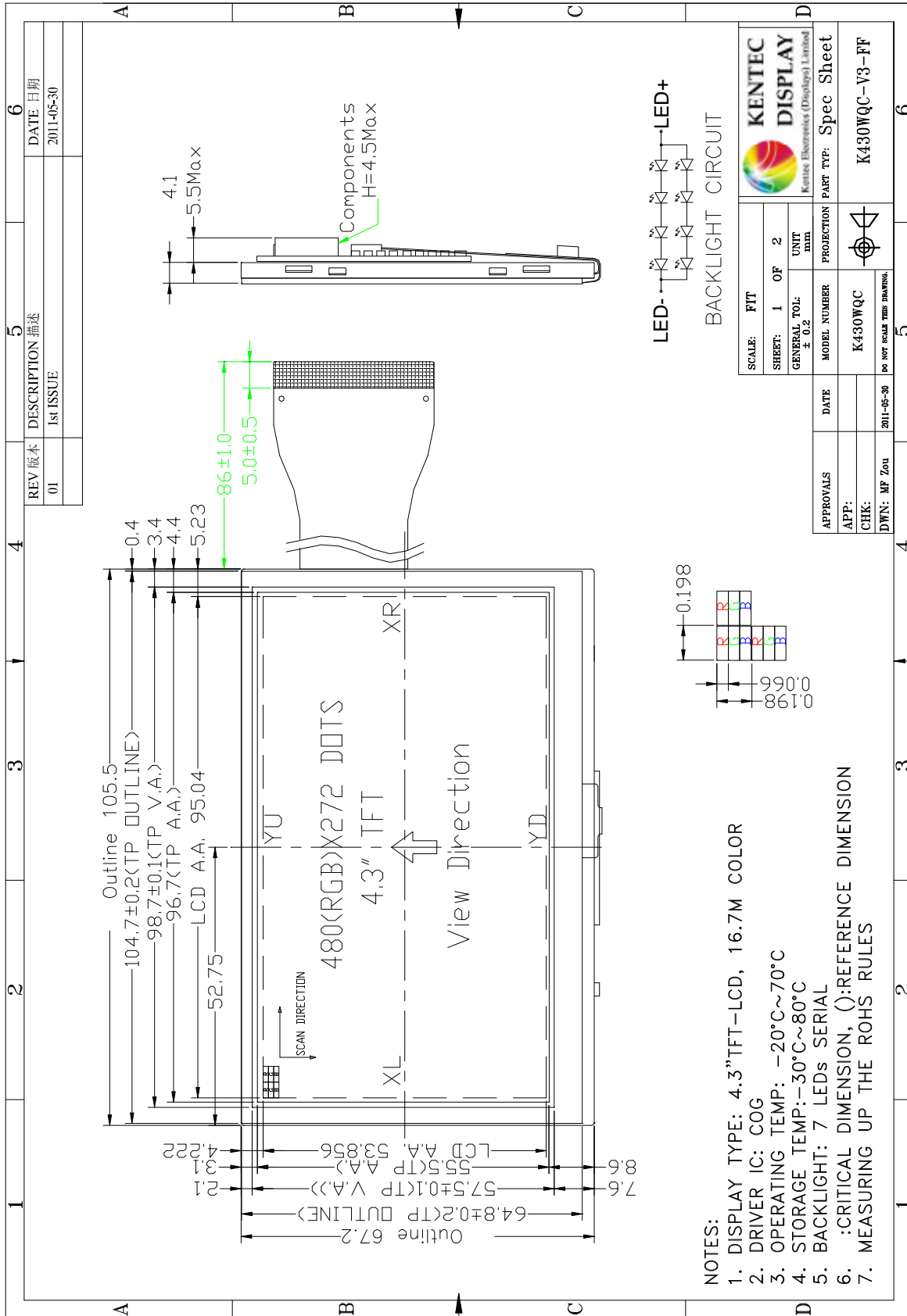

Figure 1: Outline Drawing 1

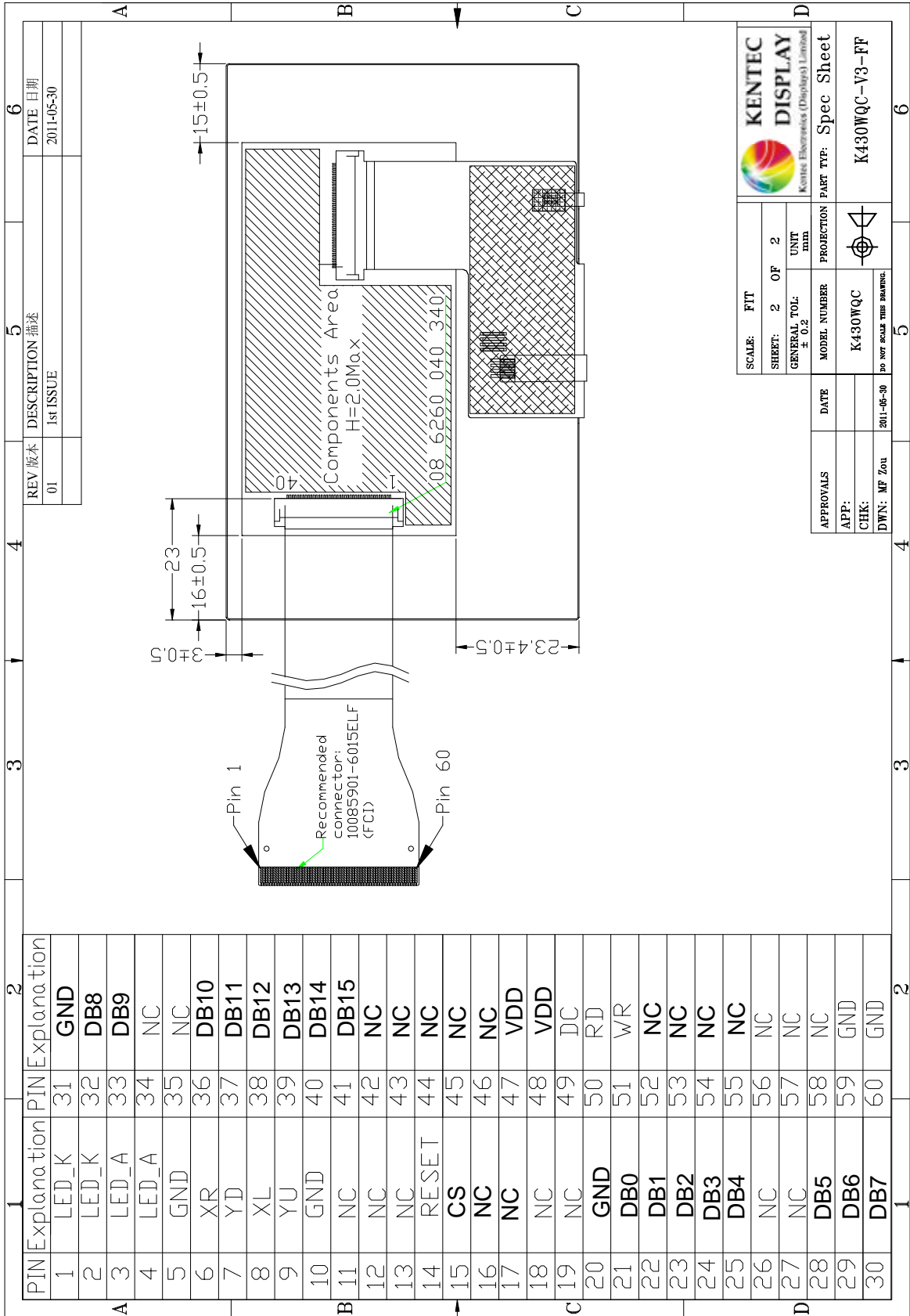

Figure 2: Outline Drawing 2



4. Interface signals

Table 2: Pin assignment

| Pin No. | Symbol | Description |
|---------|-----------|--|
| 1-2 | LED_K | Power supply for LED backlight |
| 3-4 | LED_A | |
| 5 | GND | Power supply (system ground) |
| 6 | XR | Terminal of touch panel. |
| 7 | YD | |
| 8 | XL | |
| 9 | YU | |
| 10 | GND | Power supply (system ground) |
| 11-13 | NC | No connection |
| 14 | RESET | System reset pin |
| 15 | CS | Chip select input |
| 16-19 | NC | No connection |
| 20 | GND | Un-used data pin, connect to GND |
| 21-25 | DB[0-4] | Bi-directional data bus(DB0-DB4) |
| 26-27 | NC | No connection |
| 28-30 | DB[5-7] | Bi-directional data bus(DB5-DB7) |
| 31 | GND | Un-used data pin, connect to GND |
| 32-33 | DB[8-9] | Bi-directional data bus(DB8-DB9) |
| 34-35 | NC | No connection |
| 36-41 | DB[10-15] | Bi-directional data bus(DB10-DB15) |
| 42-46 | NC | No connection |
| 47-48 | VDD | Supply voltage for logic |
| 49 | DC | Parallel Interface |
| 50 | RD | I80 system: Serves as a read signal and reads data at the low level. |
| 51 | WR | I80 system: Serves as a write signal and writes data at the rising edge. |
| 52-58 | NC | No connection |
| 59-60 | GND | Power supply (system ground) |

Note: LCD interface circuit example ().



5. Absolute Maximum Ratings

5.1 Electrical Maximum Ratings – for IC Only

Table 3: Electrical Maximum Ratings – for IC

| Parameter | Symbol | Min. | Max. | Unit | Note |
|---------------------|--------|------|------|------|------|
| Supply voltage | VCC | -0.3 | 5.0 | V | 1 |
| LED forward current | If | -- | 50 | mA | |
| LED reverse | Vr | -- | 5.0 | V | |

Note:

- 1.VCC, GND must be maintained.
- 2.The modules may be destroyed if they are used beyond the absolute maximum ratings.

5.2 Environmental Condition

Table 4

| Item | Operating temperature (Topr) | | Storage temperature (Tstg) (Note 1) | | Remark |
|---------------------|---|-------|-------------------------------------|-------|-----------------|
| | Min. | Max. | Min. | Max. | |
| Ambient temperature | -20°C | +70°C | -30°C | +80°C | Dry |
| Humidity (Note 1) | 80% max. RH for Ta ≤ 40°C < 50% RH for 40°C < Ta ≤ Maximum operating temperature | | | | No condensation |

Note 1: Product cannot sustain at extreme storage conditions for long time.

6. Electrical Specifications

Typical Electrical Characteristics

At Ta = 25 °C, VCC=IOVCC= 3.3V, GND=0V.

Table 5

| Parameter | Symbol | Conditions | Min. | Typ. | Max. | Unit |
|---------------------------------------|---------|------------------------------|---------------|------|--------|------|
| Supply voltage (logic) | VCC-GND | | 3 | 3.3 | 3.6 | V |
| Input signal voltage | VIH | | 0.8VCC | - | VCC | V |
| | VIL | | 0 | - | 0.2VCC | V |
| Supply current (Logic & LCD) | ICC | VDD=3.3V | - | 15 | 19 | mA |
| Supply current of white LED backlight | VLED | Number of LED dies = (2x4) | - | 36 | 40 | mA |



7. Optical Characteristics

Table 7: Optical specifications

| Items | Symbol | Condition | Specifications | | | Unit | Note |
|----------------|-----------|-----------------------|-----------------|---------|---------|------|------|
| | | | Min. | Typ. | Max. | | |
| Contrast Ratio | CR | | 400 | 500 | - | - | |
| Response Time | T_R+T_F | | - | 35 | - | ms | |
| Chromaticity | Red | X_R | (0.598) | (0.618) | (0.638) | - | |
| | | Y_R | (0.298) | (0.318) | (0.338) | - | |
| | Green | X_G | (0.277) | (0.297) | (0.317) | - | |
| | | Y_G | (0.525) | (0.545) | (0.565) | - | |
| | Blue | X_B | (0.114) | (0.134) | (0.154) | - | |
| | | Y_B | (0.120) | (0.140) | (0.160) | - | |
| White | X_W | (0.283) | (0.303) | (0.323) | - | | |
| | Y_W | (0.320) | (0.340) | (0.360) | - | | |
| Viewing angle | Hor. | $\phi_1 + \phi_2$ | Center CR=10 | 100 | 110 | - | deg. |
| | Ver. | $\theta_1 + \theta_2$ | | 120 | 130 | - | |
| NTSC ratio | | | | 51.7 | | % | |

Note 1: Definition of Contrast Ratio (CR):

The contrast ratio can be calculated by the following expression.

$$\text{Contrast Ratio (CR)} = L_{63} / L_0$$

L63: Luminance of gray level 63

L0: Luminance of gray level 0

$$CR = CR(10)$$

CR (X) is corresponding to the Contrast Ratio of the point X at Figure in Note 5.

Note 2: Definition of Response Time (T_R , T_F):

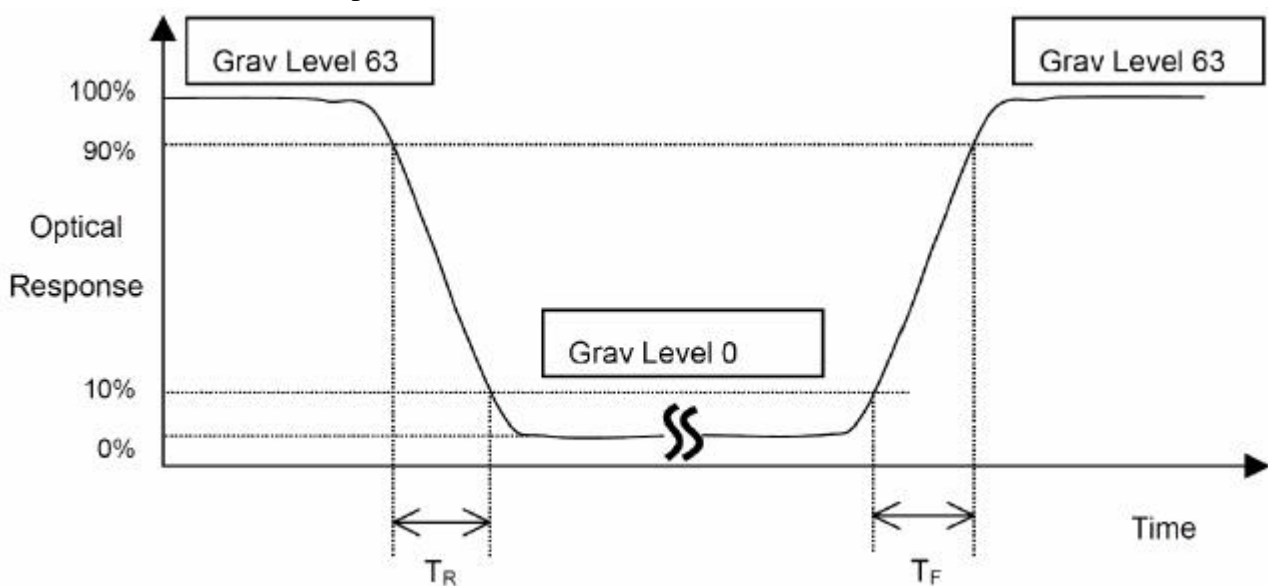

Figure 3



Note 3: Viewing Angle

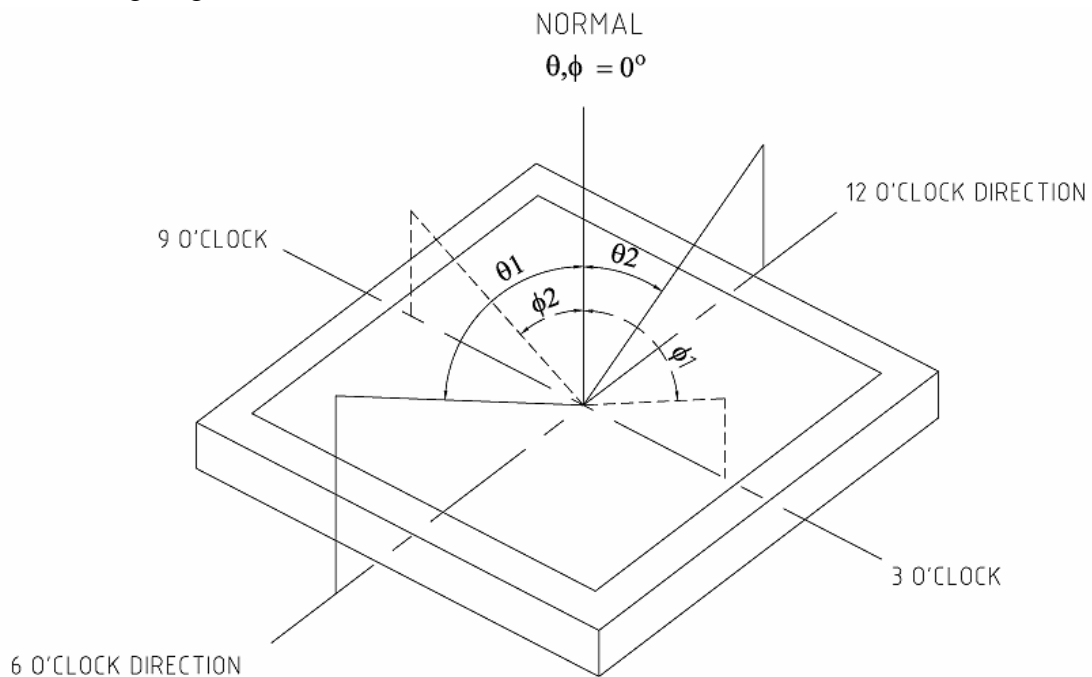

Figure 4

The above “Viewing Angle” is the measuring position with Largest Contrast Ratio; not for good image quality. View Direction for good image quality is 6 O’clock. Module maker can increase the “Viewing Angle” by applying Wide View Film.

Note 4: Measurement Set-Up:

The LCD module should be stabilized at a given temperature for 20 minutes to avoid abrupt temperature change during measuring. In order to stabilize the luminance, the measurement should be executed after lighting Backlight for 20 minutes in a windless room.

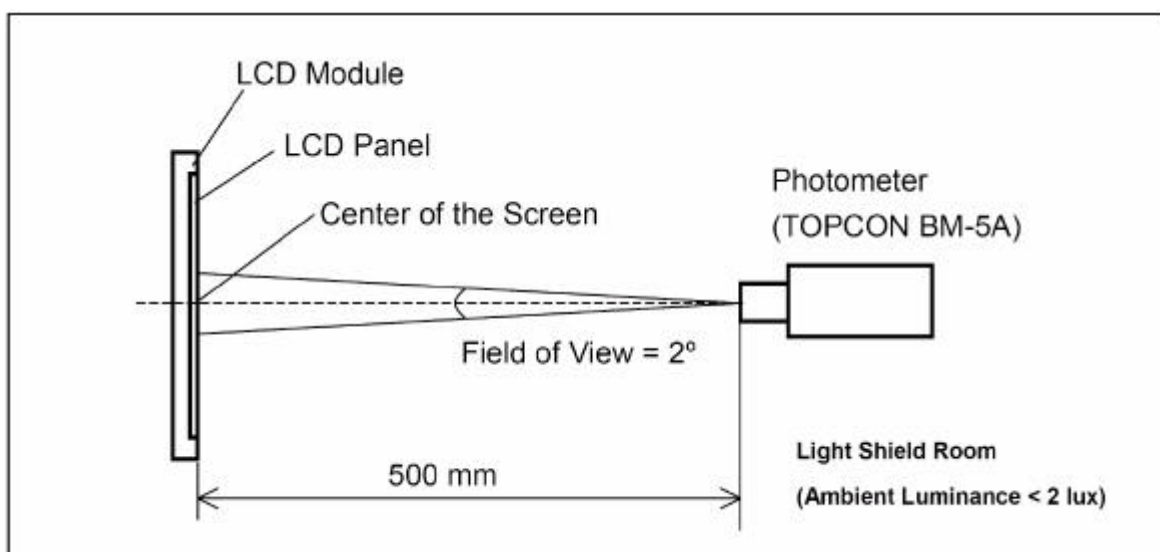

Figure 5



8. AC Characteristics and Signal timing

Please refer SSD1963 datasheet.

8.1 Driver code example for TI IDM-SBC ().

8.2 Driver code example for TI DK-LM3S9B96 ().

9. Reliability Test Item

| | Test Item | Test Condition | Remark |
|----|-----------------------------------|--|---|
| 1 | High temperature storage | 70 ; 240H | |
| 2 | Low temperature storage | -20 ; 240H | |
| 3 | High temperature High humidity | 50 , 80%RH; 240H | Operation |
| 4 | High temperature operation | 60 ; 240H | |
| 5 | Low temperature operation | -10 ; 240H | |
| 6 | Temperature Shock | -20 ? 60 ; 100cycle, 1Hrs/cycle | Non-operation |
| 7 | Electrostatic Discharge | Contact ± 4kV, Class B Air ± 8kV, Class B | |
| 8 | Image sticking | 25 , 4H | |
| 9 | Vibration | Frequency range : 10~55Hz Stoke : 1.5mm Sweep : 10~55~10Hz 2 Hours for each direction of X,Y,Z (total 6 Hours) | Non-operation JIS C7021, A-10 Conduction A : 15 minutes |
| 10 | Mechanical shock | 100G, 6ms, ±X, ±Y, ±Z, 3 times for each direction | Non-operation JIS C7021, A-10 Conduction C |
| 11 | Vibration (with carton) | Random vibration : 0.015G ² /Hz from 2~200Hz -6dB/Octave from 200~500Hz | ICE 68-34 |
| 12 | Drop (with carton) | Height : 60cm 1 corner, 3 edges, 6 surfaces | |
| 13 | Pressure | 5 kg, 5 sec | |



10. Suggestions for using LCD modules

10.1 Handling of LCM

10.1.1. The LCD screen is made of glass. Don't give excessive external shock, or drop from a high place.

10.1.2. If the LCD screen is damaged and the liquid crystal leaks out, do not lick and swallow. When the liquid is attach to your hand, skin, cloth etc, wash it off by using soap and water thoroughly and immediately.

10.1.3. Don't apply excessive force on the surface of the LCM.

10.1.4. If the surface is contaminated ,clean it with soft cloth. If the LCM is severely contaminated , use Isopropyl alcohol/Ethyl alcohol to clean. Other solvents may damage the polarizer . The following solvents is especially prohibited: water , ketone Aromatic solvents etc.

10.1.5. Exercise care to minimize corrosion of the electrode. Corrosion of the electrodes is accelerated by water droplets, moisture condensation or a current flow in a high-humidity environment.

10.1.6. Install the LCD Module by using the mounting holes. When mounting the LCD module make sure it is free of twisting, warping and distortion. In particular, do not forcibly pull or bend the I/O cable or the backlight cable.

10.1.7. Don't disassemble the LCM.

10.1.8. To prevent destruction of the elements by static electricity, be careful to maintain an optimum work environment.

- Be sure to ground the body when handling the LCD modules.
- Tools required for assembling, such as soldering irons, must be properly grounded.
- To reduce the amount of static electricity generated, do not conduct assembling and other work under dry conditions.
- The LCD module is coated with a film to protect the display surface. Exercise care when peeling off this protective film since static electricity may be generated.

10.1.9. Do not alter, modify or change the the shape of the tab on the metal frame.

10.1.10. Do not make extra holes on the printed circuit board, modify its shape or change the positions of components to be attached.



10.1.11. Do not damage or modify the pattern writing on the printed circuit board.

10.1.12. Absolutely do not modify the zebra rubber strip (conductive rubber) or heat seal connector

10.1.13. Except for soldering the interface, do not make any alterations or modifications with a soldering iron.

10.1.14. Do not drop, bend or twist LCM.

10.2 Cautions for installing and assembly if the module with Touch Panel

10.2.1. Use a buffer material (Gasket) between the touch panel and Front-case to protect damage and wrong operating. The dimension of the buffer material's edge between the TP V.A. edge is Min. 0.3mm.

10.2.2. We recommend to design a case that it can't over the boundary of the active area Max. 0.5mm in order to prevent an operation at outside of the active area which can't guarantee the specified durability, because operation at the outside of the active area cause serious damage of a transparent.

10.2.3. When design case for installing Module, you would consider give a distance about $0.2 \pm 0.15\text{mm}$ between the module edge to case inside.

10.2.4. The corners of the product are not chamfered. When positioning and fixing the product on the case, we suggest that you would provide a R part on the corner of the case so as not to apply load on the corner of the transparent module.

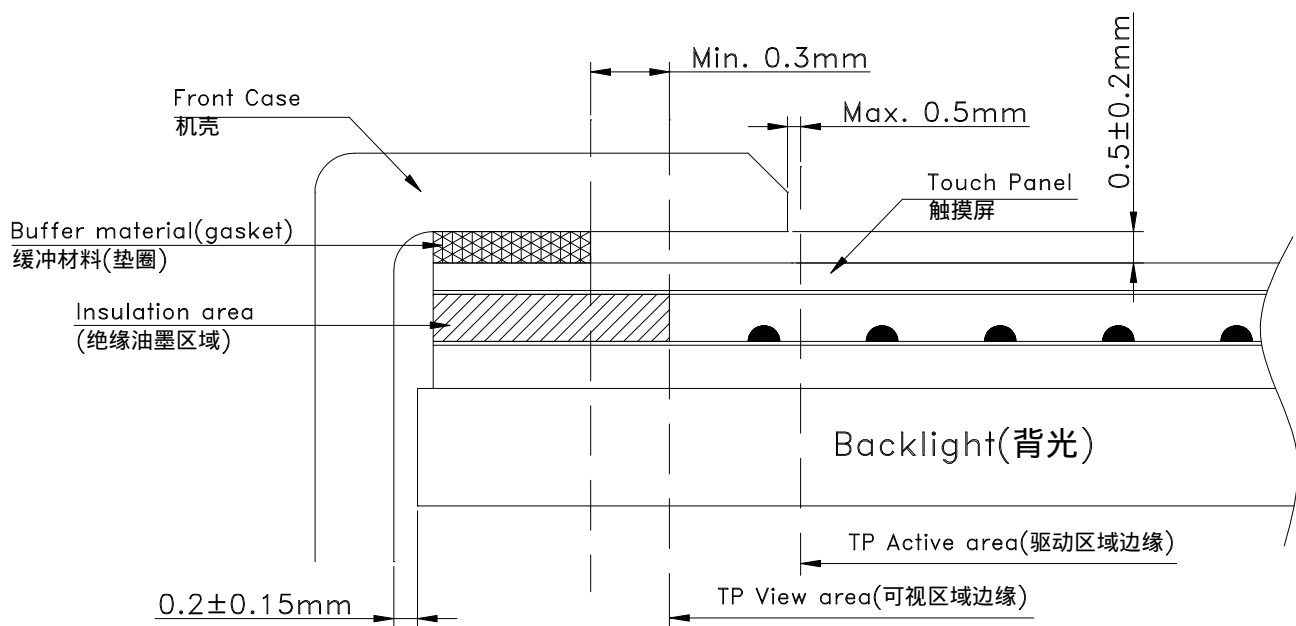



10.3 Storage

10.3.1. Store in an ambient temperature of 5 to 45 °C, and in a relative humidity of 40% to 60%. Don't expose to sunlight or fluorescent light.

10.3.2. Storage in a clean environment, free from dust, active gas, and solvent.

10.3.3. Store in antistatic container.

- END -

X-ON Electronics

Largest Supplier of Electrical and Electronic Components

Click to view similar products for [Kentec](#) manufacturer:

Other Similar products are found below :

[K70DWN2-V1-FF](#) [EB-STM32F4DISCOVERY](#) [EB-LM4F120-L35](#)