



Applications

- Phase Control
- Static Switching
- Light Dimming
- Motor Speed Control
- Kitchen Equipment
- Power Tools
- Solenoid Valve Controls:
 - Dishwashers
 - Washing Machines

- > Suitable for General Purpose AC Switching
- > 400A Surge
- > IGT = 50 mA
- > V_{DRM}/V_{RMM} 400, 600, 800 and now 1200V

CTA/CTB41

40Amp - 400/600/800/1200V - TRIAC

Absolute Maximum Ratings

	CONDITIONS	SYMBOL	RATING
RMS On-State Current (full sine wave)	$T_c = 80^\circ\text{C}$ $T_c = 95^\circ\text{C}$	TO-218 TO-218 Iso	$I_{T(RMS)}$ 40A
Non Repetitive Surge Peak On-State Current (Full Cycle, T_j Initial = 25°C)	F = 50 Hz F = 60 Hz	I_{TSM}	400A 420A
I^2t Value for fusing	$t_p = 10$ ms	I^2t	880A ² s
Critical rate of rise of on-state current $I_G = 2 \times I_{GT}$, $t_r < 100$ ns, $T_j = 125^\circ\text{C}$		di/dt	100A/ μ s
Peak Gate Current @ $T_j = 125^\circ\text{C}$	$t_p = 20$ μ s	I_{GM}	4A
Average Gate Power Dissipation @ $T_j = 125^\circ\text{C}$		$P_{G(AV)}$	1W
Storage Temperature Range		T_{stg}	-40 to +150 $^\circ\text{C}$
Operating Junction Temperature Range		T_j	-40 to +125 $^\circ\text{C}$
Isolation Voltage (CTA Series only)		V_{ISO}	2500 V_{RMS}

Electrical Characteristics

ALTERNISTOR/NO SNUBBER AND LOGIC LEVEL (3 Quadrants)			BW
I_{GT} MAX @ $V_D = 12$ V, $R_L = 3\Omega$ NOTE 1		QI-II-III	50mA
V_{GT} MAX @ $V_D = 12$ V, $R_L = 3\Omega$		QI-II-III	1.3V
V_{GD} MIN @ $V_D = V_{DRM}$, $R_L = 3.3k\Omega$	$T_j = 125^\circ\text{C}$	QI-II-III	0.2V
I_H MAX @ $I_T = 500$ mA NOTE 2			75mA
I_L MAX @ $I_G = 1.2$ I_{GT}		QI-III	70mA
I_L MAX @ $I_G = 1.2$ I_{GT}		Q-II	100mA
dv/dt MIN @ $V_D = 67\%V_{DRM}$ (gate open) NOTE 2	$T_j = 125^\circ\text{C}$		1000V/ μ s
(di/dt)c MIN without Snubber NOTE 2 & 4	$T_j = 125^\circ\text{C}$		22A/ms
STANDARD (4 Quadrants)			B
I_{GT} MAX @ $V_D = 12$ V, $R_L = 3\Omega$ NOTE 1		QI-II-III	50mA
I_{GT} MAX @ $V_D = 12$ V, $R_L = 3\Omega$ NOTE 1		QIV	100mA
V_{GT} MAX @ $V_D = 12$ V, $R_L = 3\Omega$		Q-All	1.3V
V_{GD} MIN @ $V_D = V_{DRM}$, $R_L = 3.3k\Omega$	$T_j = 125^\circ\text{C}$	Q-All	0.2V
I_H MAX @ $I_T = 100$ mA NOTE 2			75mA
I_L MAX @ $I_G = 1.2$ I_{GT}		QI-III-IV	75mA
I_L MAX @ $I_G = 1.2$ I_{GT}		Q-II	160mA
dv/dt MIN @ $V_D = 67\%V_{DRM}$ (gate open) NOTE 2	$T_j = 125^\circ\text{C}$		500V/ μ s
(dv/dt)c MIN @ (di/dt)c = 13.3 A/ms NOTE 2	$T_j = 125^\circ\text{C}$		10V/ μ s



GENERAL NOTES

1. Minimum IGT is guaranteed at 5% of IGT max.
2. For both polarities of A2 referenced to A1
3. All parameters at 25 degrees C unless otherwise specified.
4. Commutating dv/dt = 50V/ μ s, (exponential to 200 Vpk)



Static Characteristics

V_T MAX @ $I_{TM} = 35$ A, $t_p = 380\mu s$ NOTE 2	$T_j = 25^\circ\text{C}$	1.55V
V_{TO} MAX @ Threshold Voltage NOTE 2	$T_j = 125^\circ\text{C}$	0.85V
R_d MAX @ Dynamic Resistance NOTE 2	$T_j = 125^\circ\text{C}$	16rΩ
I_{DRM} MAX @ $V_{DRM} = V_{RRM}$	$T_j = 25^\circ\text{C}$	5μA
I_{RRM} MAX @ $V_{DRM} = V_{RRM}$	$T_j = 125^\circ\text{C}$	3mA

Thermal Resistances

	SYMBOL	RATING
Junction to Case (AC)	TO-218 Rth(j-c)	0.8°C/W
Junction to Case (AC)	TO-218 Isolated Rth(j-c)	1.1°C/W
Junction to Ambient	TO-218 Rth(j-a)	50°C/W
Junction to Ambient	TO-218 Isolated Rth(j-a)	50°C/W

Part Number Selection

Part Number	Voltage [Vpk]	I_T [mA]	Type	Package
CTA/CTB41-xxxB	400, 600, 800	50mA	Standard	TO-218
CTA/CTB41-xxxBW	400, 600, 800	50mA	Alternistor/No Snubber	TO-218

Part Number Designation

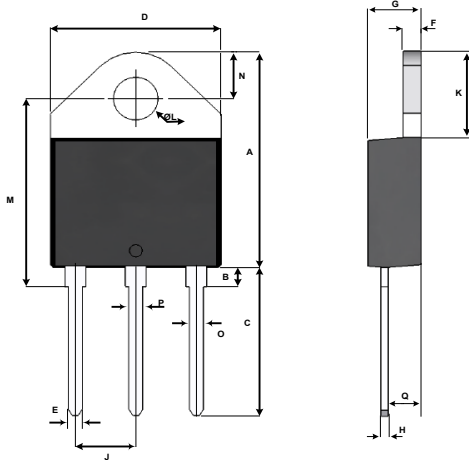
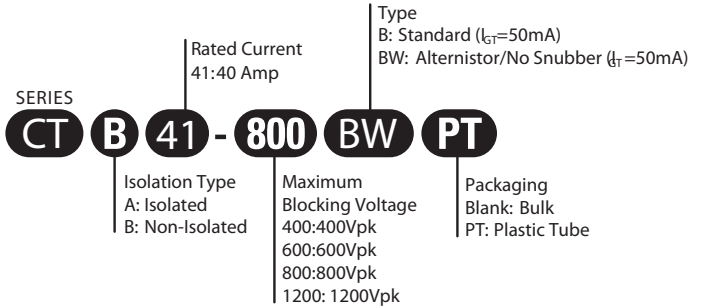

Dimensions

REF.	Millimeters			Inches		
	Min.	Typ.	Max.	Min.	Typ.	Max.
A	20.4		21.1	0.8		0.831
B		3.23			0.127	
C	14.35		15.60			0.565
D	15.1		15.5	0.594		0.610
E	1.20		1.40	0.047		0.055
F	1.45		1.55	0.057		0.061
G	4.4		4.6	0.173		0.181
H	0.5		0.7	0.020		0.028
J	5.4		5.65	0.213		0.222
K	8.0		8.25	0.315		0.325
L	4.08		4.17	0.161		0.164
M	15.8		16.5	0.622		0.650
N	4.6		4.8	0.181		0.189
O	1.20		1.40	0.047		0.055
P	1.20		1.40	0.047		0.055
Q	2.7		2.9	0.106		0.114

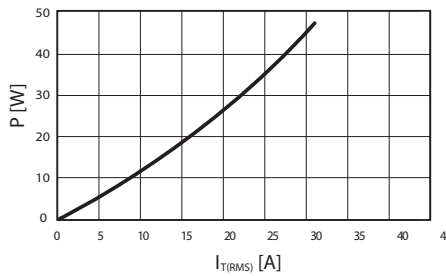

Fig. 1: Power dissipation versus RMS on-state current (full cycle).

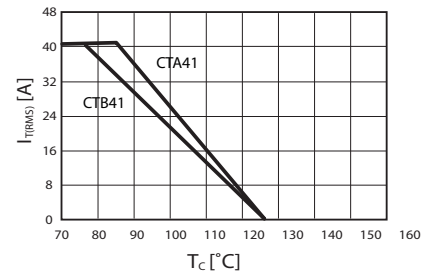

Fig. 2: RMS on-state current versus case temperature (full cycle)

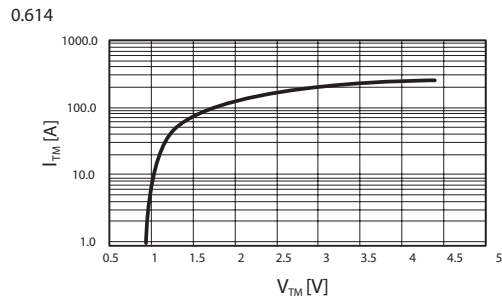

Fig. 3: On-state current versus on-state voltage (instantaneous values)

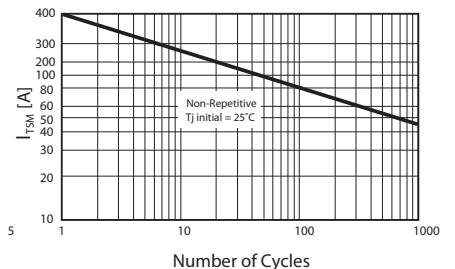

Fig. 4: Non-repetitive surge peak on-state current versus number of cycles.

X-ON Electronics

Largest Supplier of Electrical and Electronic Components

Click to view similar products for [C3 SEMI](#) manufacturer:

Other Similar products are found below :

[C3 SEMI](#)