

REV.	MODIFICATION.	DATE	DRN
01	Sales Drawing	03/09/09	PH
02	CO2010857	30/11/09	PH

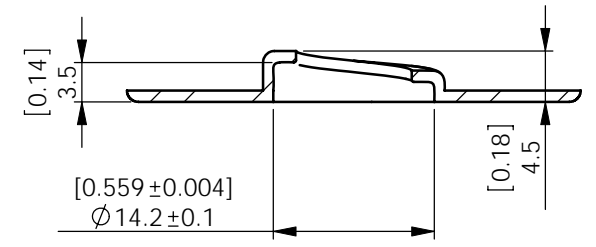
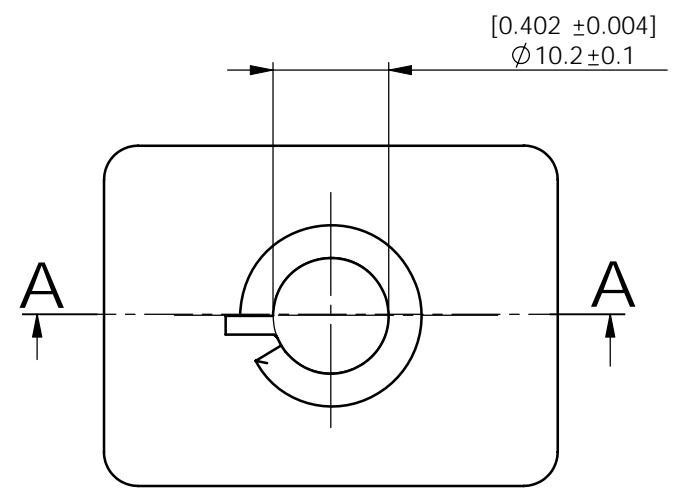
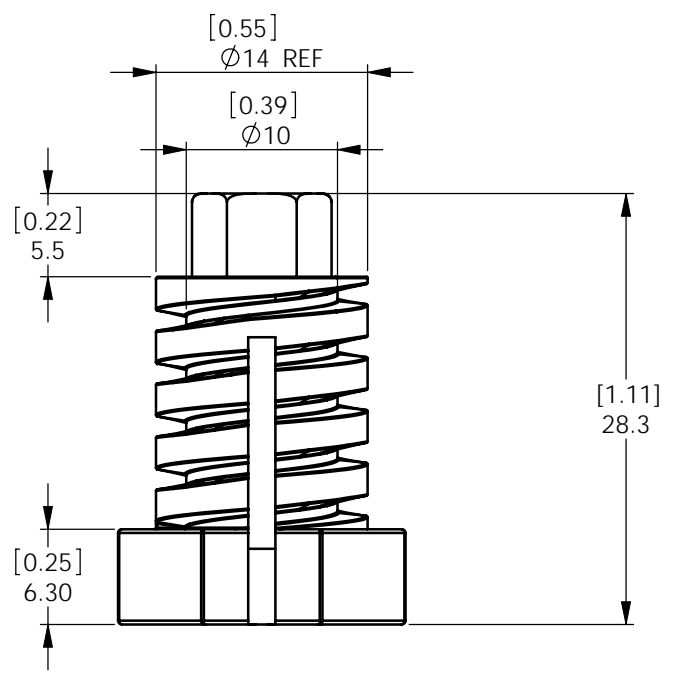
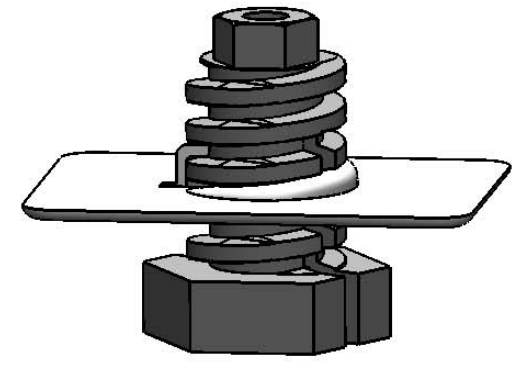
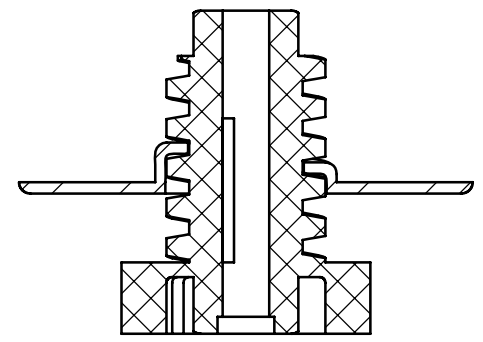
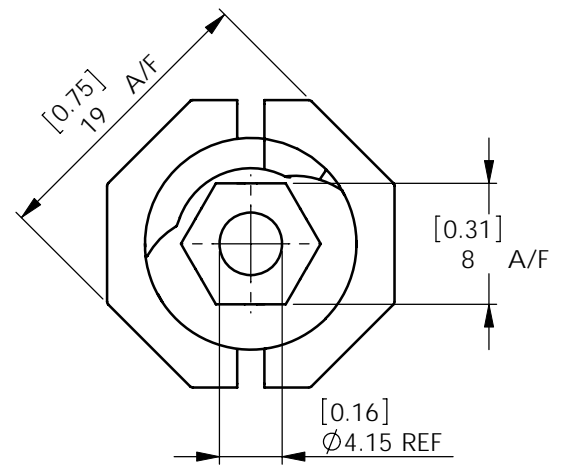

ALTERNATE UNITS FOR REFERENCE ONLY

INFORMATION CONTAINED IN THIS DOCUMENT IS CONFIDENTIAL TO RICHCO INTERNATIONAL Co. Ltd. AND MAY NOT BE DISCLOSED OR REPRODUCED IN WHOLE OR PART WITHOUT THEIR WRITTEN CONSENT.

RICHCO, INC.
WWW.RICHCO-INC.COM

ALL DIMENSIONS IN mm
GENERAL TOLERANCES ±0.25
UNLESS OTHERWISE STATED
1 DECIMAL PLACE ±
2 DECIMAL PLACES ±
ANGULAR ±1°

THIRD
ANGLE

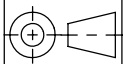

MATERIAL:
Nylon 6/6 - UL94 HB (RMS-18)

COLOUR:
Black

DESCRIPTION:
Leveling Foot

PART No:
LF-1

DRG No:
09-090

NPR No:
GB09-0026

SHEET SIZE
A4

DRN
PH

DATE
03/09/09

CHKD
PH

DATE
04/09/09

SCALE
NTS

SHEET No.
1 OF 1

PART NUMBER	PANEL THICKNESS	THREAD PITCH
LF-1	1 (0.040)	3.5 (0.138)

X-ON Electronics

Largest Supplier of Electrical and Electronic Components

Click to view similar products for [ESSENTRA](#) manufacturer:

Other Similar products are found below :

[BPF-F1G12](#) [ASPS-8-125](#) [SOF-15127](#) [HTSN-M4-5-8-2](#) [SR 3075B](#) [SR 4120B](#) [DSC-2-48](#) [MCCG-2N](#) [OFBLT-3.1-05-PP](#) [BT-4-10-BL](#)
[HR6U-3/8](#) [DSC-3-48](#) [SHR-15-6V0B](#) [SR-4050B](#) [TNM3-6.5-12-1](#) [SNGS-2.5](#) [HR6P-3/8](#) [SNGS-2.5B](#) [DSC-1-48](#) [CAT-08-PP-BU](#) [VPH-1840](#)
[BMS-SA-48](#) [TNM3-6.5-20-2](#) [SR 3075W](#) [CRLCBSR-3-01](#) [SPGS-2.5](#) [SNGS-1](#) [NTS-20](#) [SR 2664B](#) [HR8P-1/2](#) [PGS-2](#) [HR3P-3/16](#) [HR4U-1/4](#)
[NTS-10](#) [KBP-19](#) [FRB-333](#) [TLM-1550](#) [VPH-2520](#) [HTSN-M2-15-5-1](#) [SRCC-1](#) [HTSN-M3-25-6-1](#) [SNGSG-2](#) [201-USS](#) [HTSN-M2-8-5-1](#)
[HTSN-M3-25-8-1](#) [TNM3-6.5-15-2](#) [TNM3-6.5-25-2](#) [SR 3090W](#) [LCBSBM-6-01A2-RT](#) [NSP-6-4-01](#)