



ELECTRONICS, INC.
 44 FARRAND STREET
 BLOOMFIELD, NJ 07003
 (973) 748-5089
<http://www.nteinc.com>

NTE5386 & NTE5387 Silicon Controlled Rectifier (SCR) for High Speed Switching, 700 Amp, TO200AC

Maximum Ratings and Electrical Characteristics: ($T_J = +125^\circ\text{C}$ unless otherwise specified)

Repetitive Peak Voltages, V_{DRM}, V_{RRM}	
NTE5386	600V
NTE5387	1200V
Non-Repetitive Peak Off-State Voltage, V_{DSM}	
NTE5386	600V
NTE5387	1200V
Non-Repetitive Peak Reverse Blocking Voltage, V_{RSM}	
NTE5386	700V
NTE5387	1300V
Average On-State Current, $I_{T(AV)}$	
(+55°C heatsink temperature, double side cooled)	745A
(+85°C heatsink temperature, single side cooled)	261A
RMS On-State Current (+25°C heatsink temperature, double side cooled), $I_{T(RMS)}$	1535A
Continuous On-State Current (+25°C heatsink temperature, double side cooled), I_T	1180A
Peak One-Cycle Surge (Non-Repetitive) On-State Current, I_{TSM}	
(t = 10ms, 60% V_{RRM} re-applied)	9500A
(t = 10ms, $V_R \leq 10V$)	10450A
Maximum Permissible Surge Energy ($V_R \leq 10V$), I^2t	
(t = 10ms)	546000A ² sec
(t = 3ms)	400000A ² sec
Peak Forward Gate Current (Anode Positive with Respect to Cathode), I_{FGM}	20A
Peak Forward Gate Voltage (Anode Positive with Respect to Cathode), V_{FGM}	23V
Peak Reverse Gate Voltage, V_{RGM}	5V
Average Gate Power, $P_{G(AV)}$	4W
Peak Gate Power (100µs Pulse Width), P_{GM}	120W
Rate of Rise of Off-State Voltage (To 80% V_{DRM} , Gate Open-Circuit), dv/dt	200V/µs
Rate of Rise of On-State Current, di/dt	
(Gate Drive 20V, 20Ω with $t_r \leq 1\mu\text{s}$, Anode voltage $\leq 80\% V_{DRM}$)	
Repetitive	500A/µs
Non-Repetitive	1000A/µs
Operating Temperature Range, T_C	-40° to +125°C
Storage Temperature Range, T_{stg}	-40° to +150°C
Thermal Resistance, Junction-to-Heatsink, R_{thJHS}	
Double Side Cooled	0.047°C/W
Single Side Cooled	0.094°C/W

Maximum Ratings and Electrical Characteristics (Cont'd): ($T_J = +125^\circ\text{C}$ unless otherwise specified)

Peak On-State Voltage ($I_{TM} = 1500\text{A}$), V_{TM}	1.9V
Forward Conduction Threshold Voltage, V_O	1.43V
Forward Conduction Slope Resistance, r	0.31m Ω
Repetitive Peak Off-State Current (At Rated V_{DRM}), I_{DRM}	75mA
Repetitive Peak Reverse Current (At Rated V_{RRM}), I_{RRM}	75mA
Maximum Gate Current Required to Fire All Devices ($T_J = +25^\circ\text{C}$, $V_A = 6\text{V}$, $I_A = 2\text{A}$), I_{GT} ..	300mA
Maximum Gate Voltage Required to Fire All Devices ($T_J = +25^\circ\text{C}$, $V_A = 6\text{V}$, $I_A = 2\text{A}$), V_{GT}	3V
Maximum Holding Current ($T_J = +25^\circ\text{C}$, $V_A = 6\text{V}$, $I_A = 1\text{A}$), I_H	1A
Maximum Gate Voltage Which Will Not Trigger Any Device, V_{GD}	0.25V
Typical Stored Charge ($I_{TM} = 800\text{A}$, $di/dt = 50\text{A}/\mu\text{s}$, $V_{RM} = 50\text{V}$, 50% Chord Value), Q_{rr}	150 μC
Circuit Commutated Turn-Off Time Available Down To, t_q ($I_{TM} = 800\text{A}$, $di/dt = 50\text{A}/\mu\text{s}$, $V_{RM} = 50\text{V}$)	
Maximum ($dv/dt = 200\text{V}/\mu\text{s}$ to 80% V_{DRM})	20–35 μs
Typical ($dv/dt = 20\text{V}/\mu\text{s}$ to 80% V_{DRM})	15–30 μs

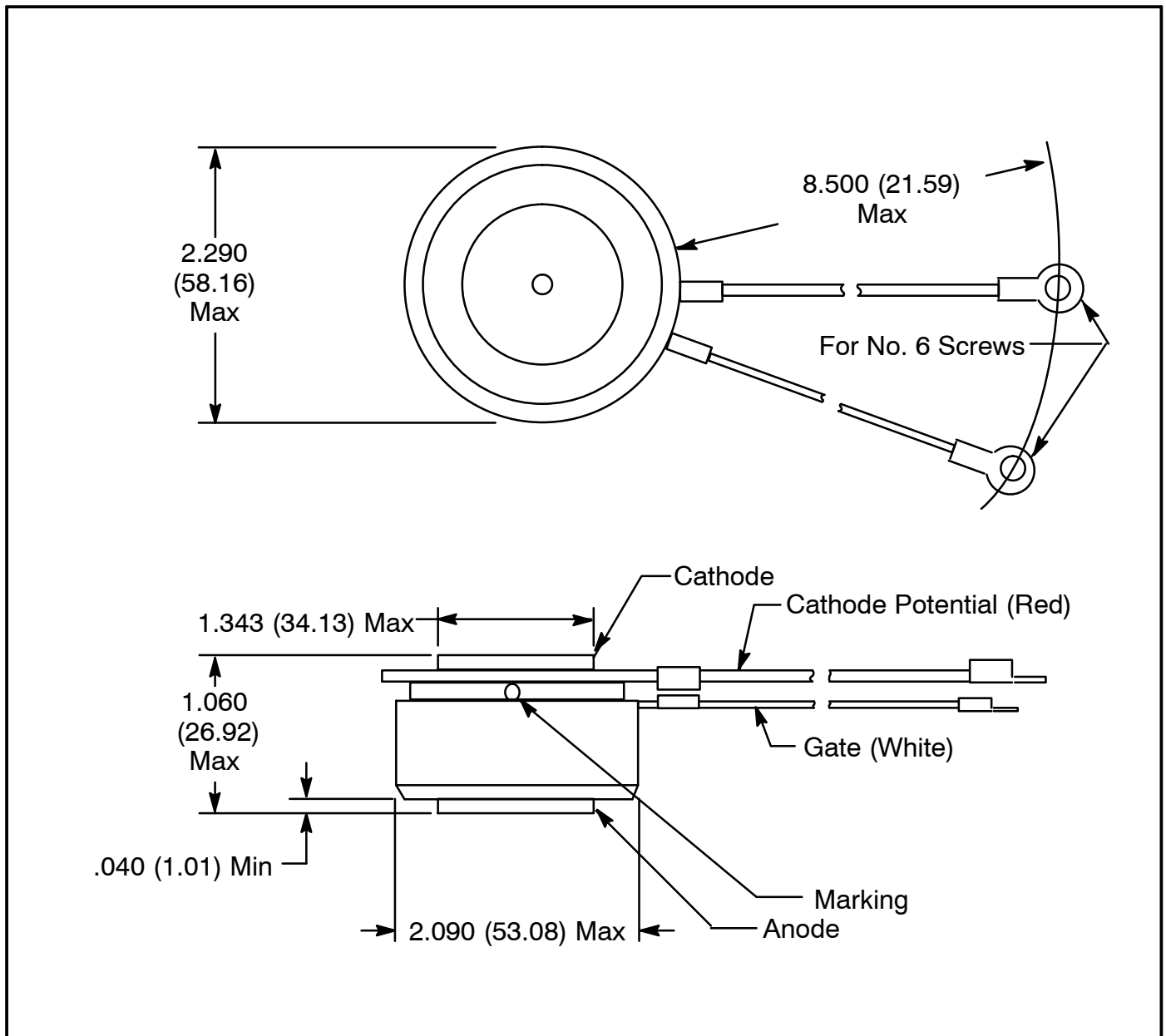

X-ON Electronics

Largest Supplier of Electrical and Electronic Components

Click to view similar products for [SCRs](#) category:

Click to view products by [NTE](#) manufacturer:

Other Similar products are found below :

[NTE5428](#) [NTE5448](#) [NTE5457](#) [NTE5511](#) [T1500N16TOF VT](#) [T720N18TOF](#) [T880N14TOF](#) [T880N16TOF](#) [TN1205H-6G](#) [TN1215-800B-TR](#)
[TS110-7UF](#) [TT104N12KOF-A](#) [TT104N12KOF-K](#) [TT162N16KOF-A](#) [TT162N16KOF-K](#) [TT330N16AOF](#) [VS-111RKI120PBF](#) [VS-16RIA100](#)
[VS-22RIA20](#) [VS-2N5206](#) [VS-2N685](#) [VS-40TPS08A-M3](#) [VS-50RIA10](#) [057219R](#) [T1190N16TOF VT](#) [T1220N22TOF VT](#) [T201N70TOH](#)
[T830N14TOF](#) [T830N18TOF](#) [TD92N16KOF-A](#) [TT250N12KOF-K](#) [VS-ST180S12P0V](#) [VS-25RIA40](#) [VS-16RIA120](#) [VS-30TPS08PBF](#)
[TN1215-800G-TR](#) [NTE5427](#) [NTE5442](#) [X0405NF 1AA2](#) [VS-ST300S20P0PBF](#) [T2160N28TOF VT](#) [TT251N16KOF-K](#) [VS-22RIA100](#) [VS-](#)
[16RIA40](#) [CR02AM-8#F00](#) [VS-ST110S12P0VPBF](#) [TD250N16KOF-A](#) [GA301A](#) [VS-ST110S16P0](#) [VS-10RIA10](#)