



ELECTRONICS, INC.
 44 FARRAND STREET
 BLOOMFIELD, NJ 07003
 (973) 748-5089
<http://www.nteinc.com>

NTE5491 thru NTE5496 Silicon Controlled Rectifier (SCR) 10 Amp, TO48

Description:

The NTE5491 through NTE5496 are silicon controlled rectifiers designed primarily for half-wave AC control applications such as motor controls, heating controls, power supplies, or wherever half-wave silicon gate-controlled, solid-state devices are needed.

Features:

- Glass-Passivated Junctions and Center Gate Fire for Greater Parameter Uniformity and Stability
- Blocking Voltage to 600 Volts

Absolute Maximum Ratings: ($T_J = +125^{\circ}\text{C}$ unless otherwise specified)

Peak Repetitive Off-State Blocking Voltage, V_{RRM}, V_{DRM}	
NTE5491	100V
NTE5492	200V
NTE5494	400V
NTE5496	600V
Peak Non-Repetitive Reverse Voltage, V_{RSM}	
NTE5491	150V
NTE5492	300V
NTE5494	500V
NTE5496	720V
RMS On-State Current (All Conduction Angles), $I_{T(RMS)}$	25A
Average On-State Current ($T_C = +65^{\circ}\text{C}$), $I_{T(AV)}$	16A
Peak Non-Repetitive Surge Current, I_{TSM}	
(One cycle, 60Hz, Preceeded and followed by rated Current and Voltage)	150A
Circuit Fusing Considerations ($T_J = -40^{\circ}$ to $+125^{\circ}\text{C}$, $t = 1$ to 8.3ms), I^2t	93A ² s
Peak Gate Power Dissipation, P_{GM}	5W
Average Gate Power Dissipation, $P_{G(AV)}$	500mW
Peak Forward Gate Current, I_{GT}	
NTE5491, NTE5492, NTE5494	2.0A
NTE5496	1.2A
Operating Junction Temperature Range, T_J	-65° to $+125^{\circ}\text{C}$
Storage Temperature Range, T_{stg}	-65° to $+150^{\circ}\text{C}$
Typical Thermal Resistance, Junction-to-Case, R_{thJC}	2°C/W
Stud Torque	30 in.lb.

Electrical Characteristics: ($T_J = +25^\circ\text{C}$ unless otherwise specified)

Parameter	Symbol	Test Conditions	Min	Typ	Max	Unit
Average Forward Blocking Current NTE5491	$I_{D(AV)}$	Rated V_{DRM} , Gate Open $T_J = +125^\circ\text{C}$	-	-	6.5	mA
NTE5492			-	-	6.0	mA
NTE5494			-	-	4.0	mA
NTE5496			-	-	2.5	mA
Average Reverse Blocking Current NTE5491	$I_{R(AV)}$	Rated V_{RRM} , Gate Open $T_J = +125^\circ\text{C}$	-	-	6.5	mA
NTE5492			-	-	6.0	mA
NTE5494			-	-	4.0	mA
NTE5496			-	-	2.5	mA
Peak Forward Blocking Current	I_{DRM}	Rated V_{DRM} , Gate Open	-	-	10	μA
Peak Reverse Blocking Current	I_{RRM}	Rated V_{RRM} , Gate Open, $T_J = +125^\circ\text{C}$	-	-	20	mA
Peak On-State Voltage	V_{TM}	$I_{TM} = 50.3\text{A}$ Peak, Note 1	-	-	2	V
DC Gate-Trigger Current	I_{GT}	$V_{AK} = 12\text{VDC}$, $R_L = 50\Omega$	-	-	40	mA
DC Gate-Trigger Voltage	V_{GT}	$V_{AK} = 12\text{VDC}$, $R_L = 50\Omega$	-	0.65	2.0	V
Gate Non-Trigger Voltage	V_{GD}	Rated V_{DRM} , $R_L = 50\Omega$, $T_J = +125^\circ\text{C}$	0.25	-	-	V
DC Holding Current	I_H	$V_{AK} = 12\text{V}$, Gate Open	-	7.3	50	mA
Critical Rate-of-Rise of Off-State Voltage	dv/dt	Rated V_{DRM} , Exponential Waveform, $T_C = +125^\circ\text{C}$, Gate Open	-	30	-	$\text{V}/\mu\text{s}$

Note 1. Pulse Test: Pulse Width $\leq 1\text{ms}$, Duty Cycle $\leq 2\%$.

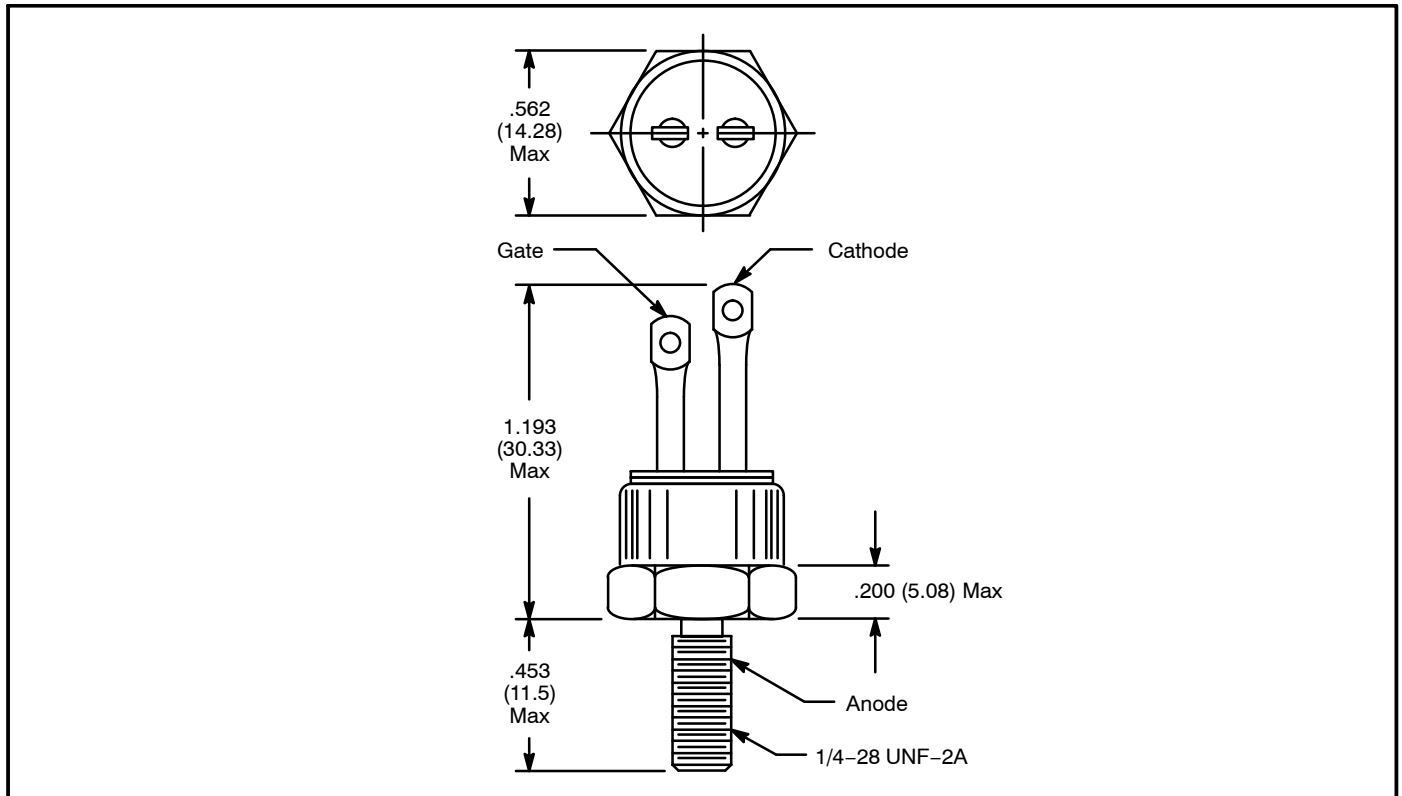

X-ON Electronics

Largest Supplier of Electrical and Electronic Components

Click to view similar products for [SCRs category](#):

Click to view products by [NTE manufacturer](#):

Other Similar products are found below :

[NTE5428](#) [NTE5448](#) [NTE5457](#) [NTE5511](#) [T1500N16TOF VT](#) [T720N18TOF](#) [T880N14TOF](#) [T880N16TOF](#) [TN1205H-6G](#) [TN1215-800B-TR](#)
[TS110-7UF](#) [TT104N12KOF-A](#) [TT104N12KOF-K](#) [TT162N16KOF-A](#) [TT162N16KOF-K](#) [TT330N16AOF](#) [VS-111RKI120PBF](#) [VS-16RIA100](#)
[VS-22RIA20](#) [VS-2N5206](#) [VS-2N685](#) [VS-40TPS08A-M3](#) [VS-50RIA10](#) [057219R](#) [T1190N16TOF VT](#) [T1220N22TOF VT](#) [T201N70TOH](#)
[T830N14TOF](#) [T830N18TOF](#) [TD92N16KOF-A](#) [TT250N12KOF-K](#) [VS-ST180S12P0V](#) [VS-25RIA40](#) [VS-16RIA120](#) [VS-30TPS08PBF](#)
[TN1215-800G-TR](#) [NTE5427](#) [NTE5442](#) [X0405NF 1AA2](#) [VS-ST300S20P0PBF](#) [T2160N28TOF VT](#) [TT251N16KOF-K](#) [VS-22RIA100](#) [VS-](#)
[16RIA40](#) [CR02AM-8#F00](#) [VS-ST110S12P0VPBF](#) [TD250N16KOF-A](#) [GA301A](#) [VS-ST110S16P0](#) [VS-10RIA10](#)