

ProLight PACJ-28FxL-xC4N
28W COB Light-Engine LEDs
Technical Datasheet
Version: 1.2

ProLight Opto ® ProEngine Series

Features

- High flux density of lighting source
- Good color uniformity
- RoHS compliant
- Energy Star binning structure, neutral white and warm white with 2 steps guarantee.
- More energy efficient than incandescent and most halogen lamps
- No UV
- Long lifetime
- 5 year warranty

Main Applications

- Par lighting
- LED Bulb
- Ceiling lighting
- Spot lighting
- Down lighting

Introduction

·The input power is 28 Watt, the multi-chip ultra high power ProEngine Series delivers never before seen luminous flux output from a single emitter. The superficial illuminating nature of ProEngine makes them the preference in Par lighting, typical applications include commercial down lighting, LED bulb, accent lighting, ceiling lighting and spot lighting.

Emitter Mechanical Dimensions

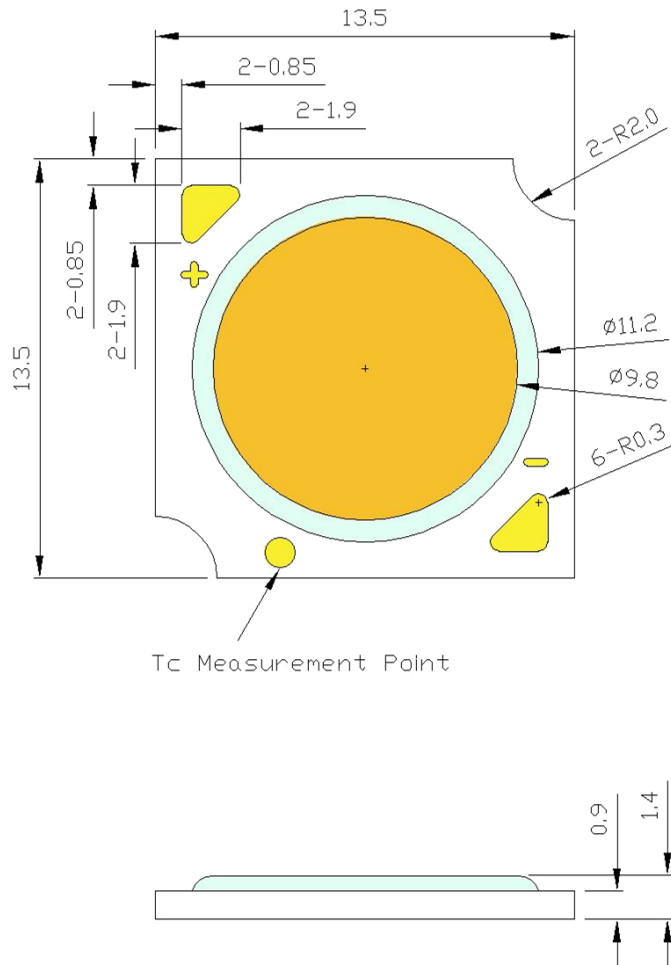

Notes:

1. Slots in aluminum-core PCB for M3 mounting screw.
2. Solder pads are labeled "+" and "-" to denote positive and negative, respectively.
3. Drawing not to scale.
4. All dimensions are in millimeters.
5. Unless otherwise indicated, tolerances are ± 0.30 mm.
6. **Please do not use a force of over 0.3kgf impact or pressure on the lens of the LED, otherwise it will cause a catastrophic failure.**

*The appearance and specifications of the product may be modified for improvement without notice.

Flux Characteristics, $T_c = 25^\circ\text{C}$

Radiation Pattern	Color	Part Number COB	DC Forward Current (mA)		Luminous Flux Φ_v (lm)		CRI Min.	R9 Min.
			360*	720	Min.	Typ.		
Lambertian	White	PACJ-28FWL-AC4N	360*	720	1840	2100	70	-
	Neutral White	PACJ-28FNL-AC4N	360*	720	1800	2060	70	-
	Warm White	PACJ-28FVL-AC4N	360*	720	1720	1980	70	-
	White	PACJ-28FWL-BC4N	360*	720	1800	2060	80	0
	Neutral White	PACJ-28FNL-BC4N	360*	720	1765	2020	80	0
	Warm White	PACJ-28FVL-BC4N	360*	720	1685	1940	80	0
	White	PACJ-28FWL-DC4N	360*	720	1440	1660	90	50
	Neutral White	PACJ-28FNL-DC4N	360*	720	1340	1620	90	50
	Warm White	PACJ-28FVL-DC4N	360*	720	1300	1580	90	50
	Neutral White	PACJ-28FNL-EC4N	360*	720	1300	1520	95	90
	Warm White	PACJ-28FVL-EC4N	360*	720	1120	1360	95	90

- The mark "*" indicated product is tested and binned at the specified drive current.
- ProLight maintains a tolerance of $\pm 7\%$ on flux and power measurements.
- ProLight maintains a tolerance of ± 2 on CRI measurements.
- Please do not drive at rated current more than 1 second without proper heat sink.

Electrical Characteristics at 360mA, $T_c = 25^\circ\text{C}$

Color	Forward Voltage V_F (V)			Thermal Resistance Junction to Board ($^\circ\text{C}/\text{W}$)
	Min.	Typ.	Max.	
White	33.7	36.0	38.3	1.4
Neutral White	33.7	36.0	38.3	1.4
Warm White	33.7	36.0	38.3	1.4

- ProLight maintains a tolerance of $\pm 1\text{V}$ for Voltage measurements.

Optical Characteristics at 360mA, $T_c = 25^\circ\text{C}$

Color	Bin Code	Color Temperature CCT			Total included Angle (degrees) $\theta_{0.90\text{V}}$	Viewing Angle (degrees) $2\theta_{1/2}$
		Min.	Typ.	Max.		
White	V0	4840 K	5000 K	5230 K	160	120
	W0	5400 K	5700 K	5910 K	160	120
	X0	6250 K	6500 K	6840 K	160	120
Neutral White	S0	3890 K	4000 K	4080 K	160	120
	M0	2660 K	2700 K	2790 K	160	120
Warm White	N0	2970 K	3000 K	3110 K	160	120
	Q0	3380 K	3500 K	3550 K	160	120

- ProLight maintains a tolerance of $\pm 5\%$ for CCT measurements.

Supply Specifications

Part Number	CRI	Color Bin Code						
		V0	W0	X0	S0	M0	N0	Q0
PACJ-28F _x L-AC4N	70	V			V	V		
PACJ-28F _x L-BC4N	80	V	V	V	V	V	V	V
PACJ-28F _x L-DC4N	90	V			V	V	V	V
PACJ-28F _x L-EC4N	95				V	V	V	

Electro-Optical Characteristics, $T_c = 25^\circ\text{C}$

I_F (mA)	V_F (V)	Power (W)	PACJ-28FWL-AC4N		PACJ-28FNL-AC4N		PACJ-28FVL-AC4N	
			Flux (lm)	lm/W	Flux (lm)	lm/W	Flux (lm)	lm/W
240	34.63	8.31	1560	187.7	1532	184.3	1472	177.1
360*	36.00	12.96	2100	162.0	2060	159.0	1980	152.8
480	37.23	17.87	2640	147.7	2588	144.8	2488	139.2
600	38.42	23.05	3180	138.0	3117	135.2	2996	130.0
720	39.53	28.46	3720	130.7	3645	128.1	3505	123.1
I_F (mA)	V_F (V)	Power (W)	PACJ-28FWL-BC4N		PACJ-28FNL-BC4N		PACJ-28FVL-BC4N	
			Flux (lm)	lm/W	Flux (lm)	lm/W	Flux (lm)	lm/W
240	34.63	8.31	1532	184.3	1502	180.7	1442	173.5
360*	36.00	12.96	2060	159.0	2020	155.9	1940	149.7
480	37.23	17.87	2588	144.8	2538	142.1	2438	136.4
600	38.42	23.05	3117	135.2	3057	132.6	2937	127.4
720	39.53	28.46	3645	128.1	3575	125.6	3435	120.7
I_F (mA)	V_F (V)	Power (W)	PACJ-28FWL-DC4N		PACJ-28FNL-DC4N		PACJ-28FVL-DC4N	
			Flux (lm)	lm/W	Flux (lm)	lm/W	Flux (lm)	lm/W
240	34.63	8.31	1233	148.4	1207	145.2	1180	142.0
360*	36.00	12.96	1660	128.1	1620	125.0	1580	121.9
480	37.23	17.87	2087	116.8	2033	113.8	1980	110.8
600	38.42	23.05	2513	109.0	2447	106.1	2380	103.3
720	39.53	28.46	2940	103.3	2860	100.5	2780	97.7
I_F (mA)	V_F (V)	Power (W)	PACJ-28FNL-EC4N		PACJ-28FVL-EC4N			
			Flux (lm)	lm/W	Flux (lm)	lm/W		
240	34.63	8.31	1133	136.4	1013	121.9		
360*	36.00	12.96	1520	117.3	1360	104.9		
480	37.23	17.87	1907	106.7	1707	95.5		
600	38.42	23.05	2293	99.5	2053	89.1		
720	39.53	28.46	2680	94.2	2400	84.3		

● All values are reference only.

Absolute Maximum Ratings

Parameter	White/Neutral White/Warm White
Max DC Forward Current (mA)	720
Max Voltage at 720mA	42
Peak Pulsed Forward Current (mA)	1080 (less than 1/10 duty cycle@1KHz)
ESD Sensitivity (HBM per MIL-STD-883E Method 3015.7)	±2000V
LED Junction Temperature	120°C
Operating Board Temperature at Maximum DC Forward Current	-40°C - 90°C
Storage Temperature	-40°C - 120°C
Reverse Voltage	Not designed to be driven in reverse bias

Color Bin

White Binning Structure Graphical Representation

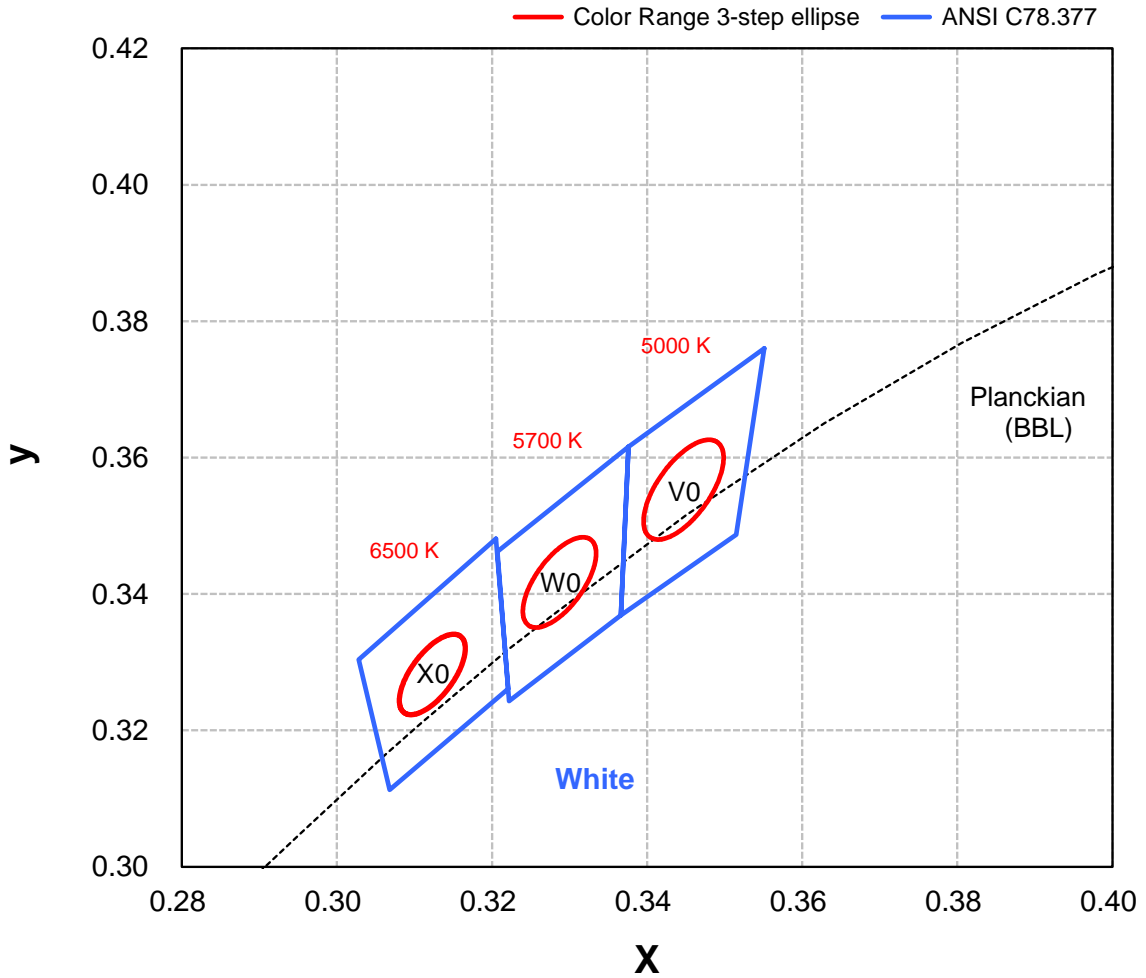

White Bin Structure

Bin Code	Center	Oval parameter	Typ. CCT (K)	Bin Code	Center	Oval parameter	Typ. CCT (K)
V0	x	a	5000	X0	x	a	6500
	y	b			y	B	
		e°				e°	
W0	x	a	5700				
	y	B					
		e°					

- Color range stay within MacAdam “3-step” ellipse from the chromaticity center.
- The chromaticity center refers to ANSI C78.377.
- Tolerance on each color bin (x , y) is ± 0.005

Color Bin

Neutral White Binning Structure Graphical Representation

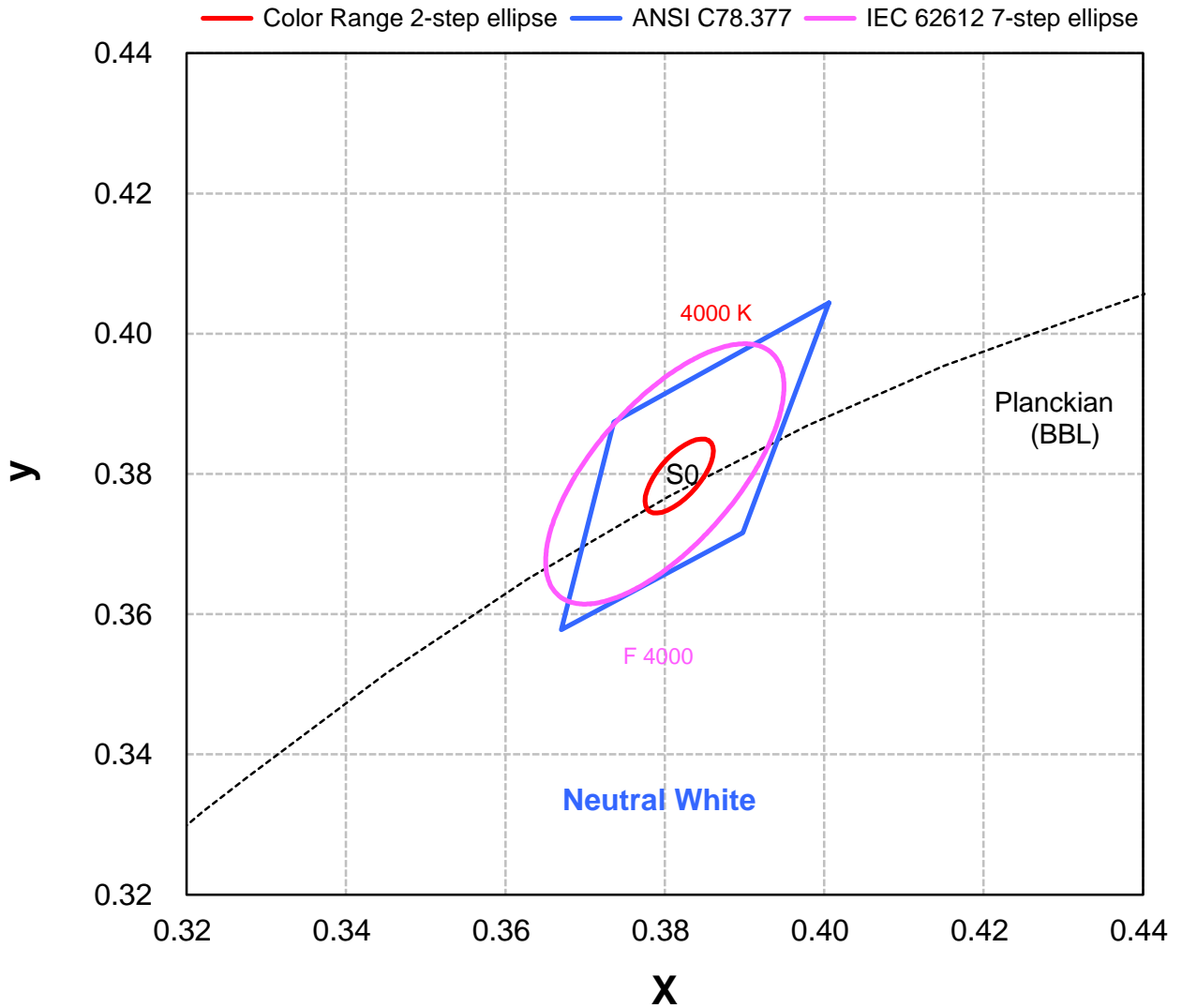

Neutral White Bin Structure

Bin Code	Center	Oval parameter	Typ. CCT (K)
S0	x	0.3818	4000
	y	0.3797	
	a	0.00626	
	b	0.00268	
		e°	53.72

- Color range stay within MacAdam "2-step" ellipse from the chromaticity center.
- The chromaticity center refers to ANSI C78.377.
- Tolerance on each color bin (x , y) is ± 0.005

Color Bin

Warm White Binning Structure Graphical Representation

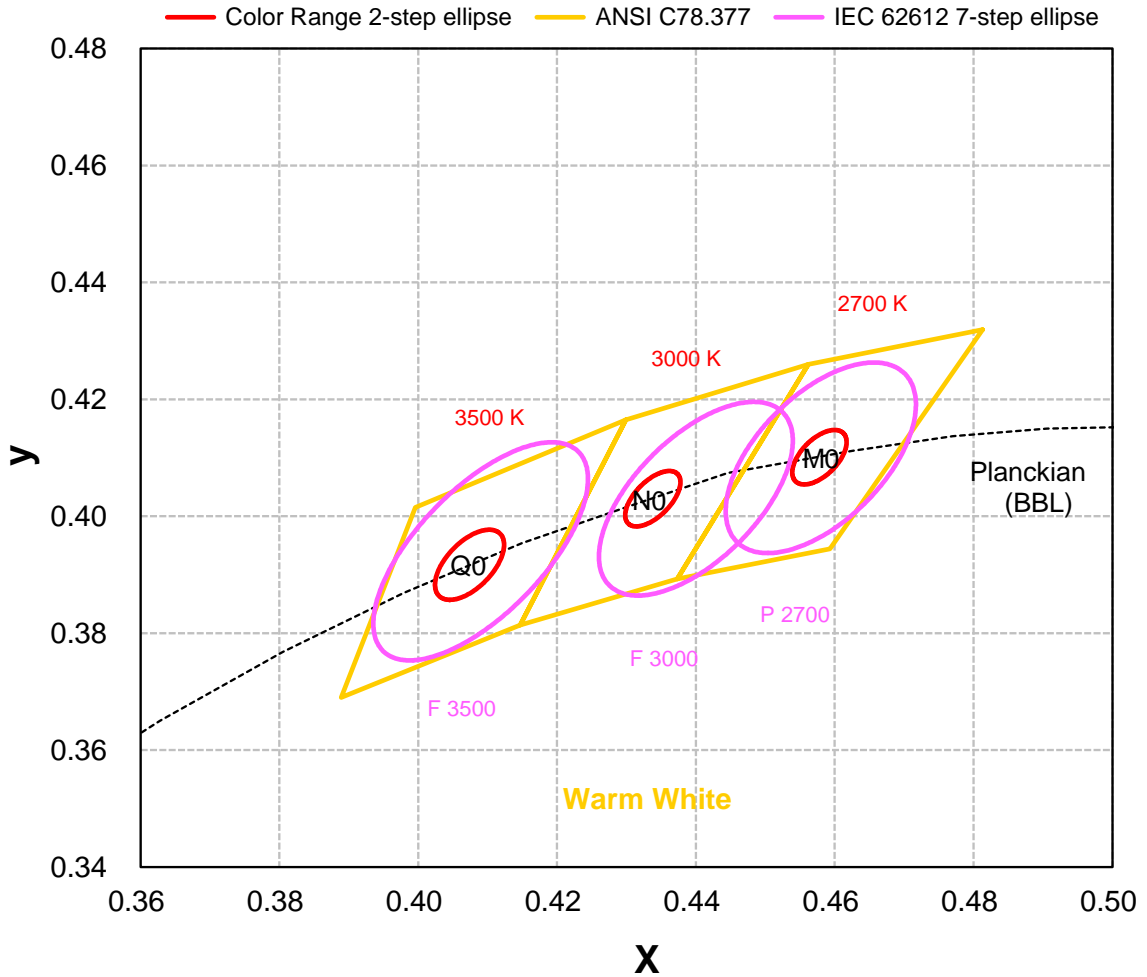

Warm White Bin Structure

Bin Code	Center	Oval parameter	Typ. CCT (K)	Bin Code	Center	Oval parameter	Typ. CCT (K)
M0	x	0.4578	2700	Q0	x	0.4074	3500
	y	0.4101			y	0.3917	
	a	0.0054			a	0.00695	
		b	0.0028			b	0.00352
		e°	53.70			e°	54.09
N0	x	0.4338	3000				
	y	0.4030					
	a	0.00556					
		b	0.00272				
		e°	53.22				

- Color range stay within MacAdam “2-step” ellipse from the chromaticity center.
- The chromaticity center refers to ANSI C78.377.
- Tolerance on each color bin (x , y) is ± 0.005

Color Spectrum, $T_c = 25^\circ\text{C}$

1. PACJ-21WL-AC4N 、 PACJ-28FNL-AC4N 、 PACJ-28FVL-AC4N

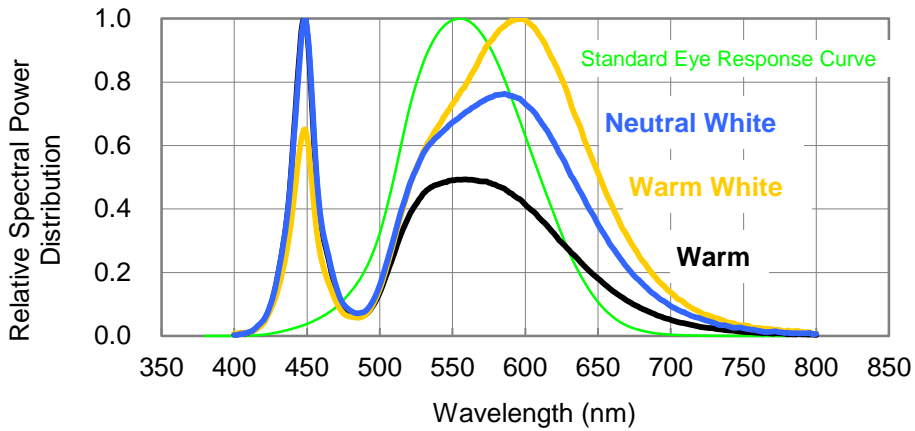

2. PACJ-28FWL-BC4N 、 PACJ-28FNL-BC4N 、 PACJ-28FVL-BC4N

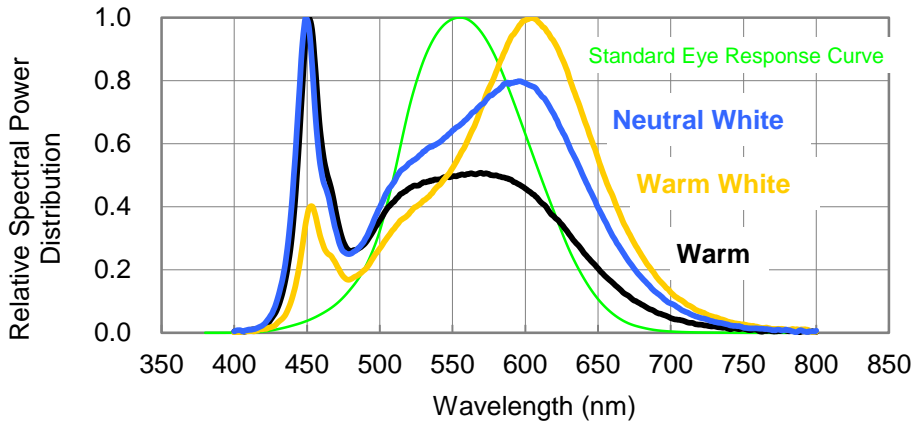

Color Spectrum, $T_c = 25^\circ\text{C}$

3. PACJ-28FWL-DC4N 、 PACJ-28FNL-DC4N 、 PACJ-28FVL-DC4N

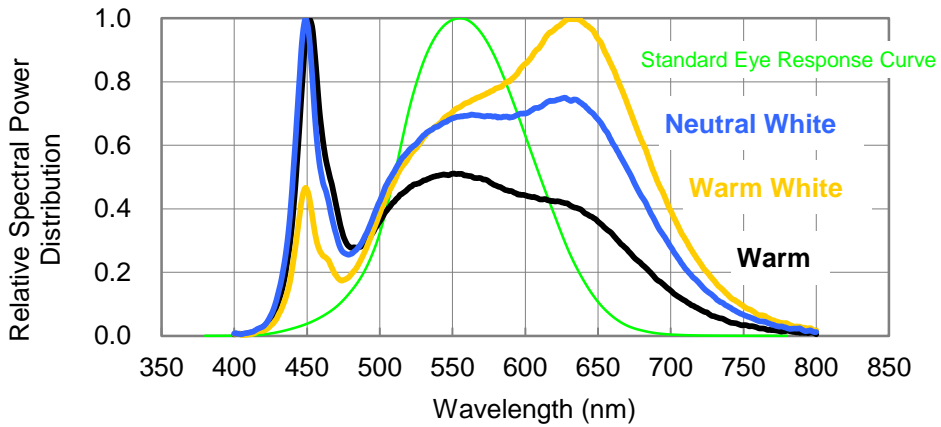

4. PACJ-28FNL-EC4N 、 PACJ-28FVL-EC4N

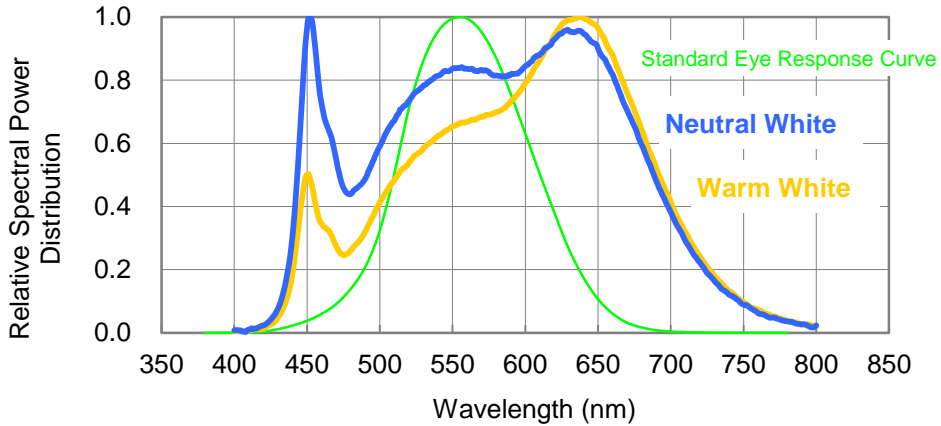

Case Temperature Relative Characteristics

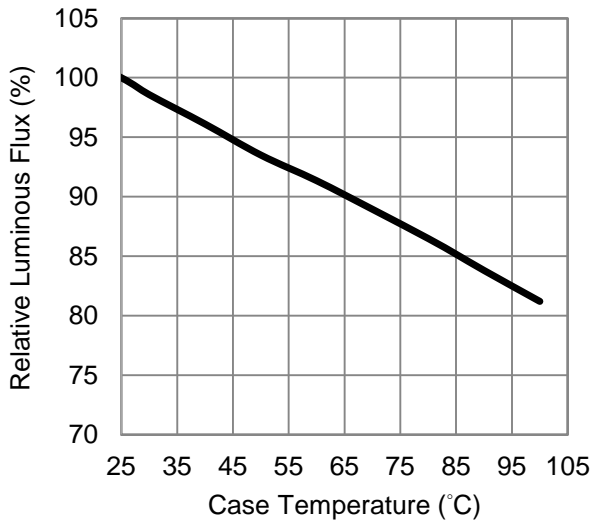

Fig 1. Case Temperature vs. Relative Luminous Flux at 360mA.

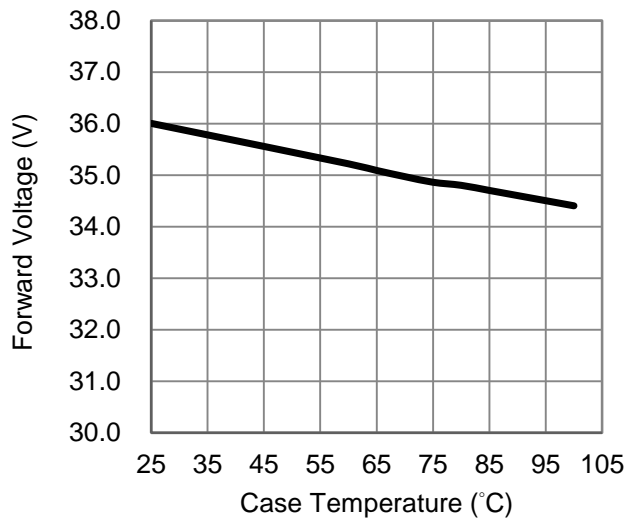

Fig 2. Case Temperature vs. Forward Voltage at 360mA.

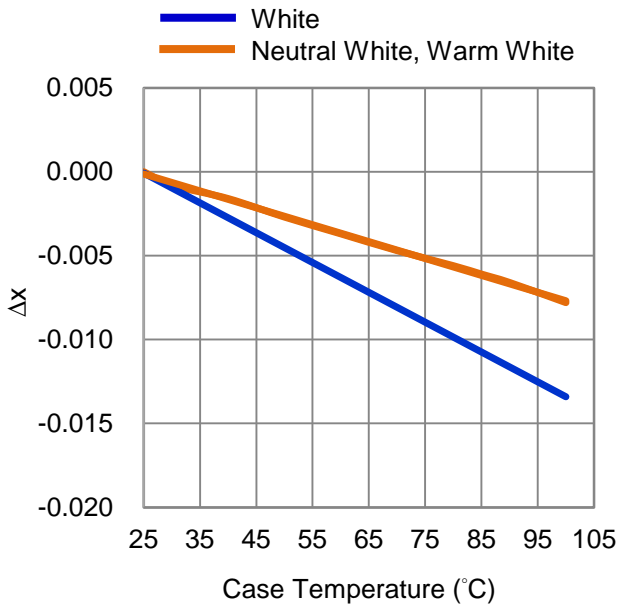

Fig 3. Case Temperature vs. Chromaticity Coordinate Δx at 360mA.

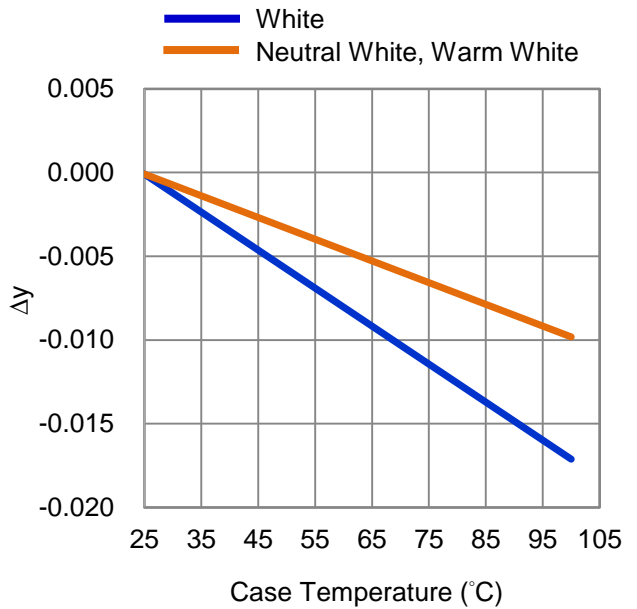

Fig 4. Case Temperature vs. Chromaticity Coordinate Δy at 360mA.

Forward Current Relative Characteristics

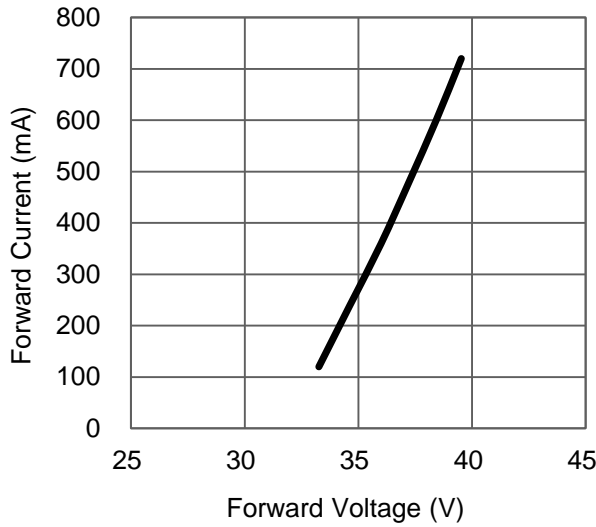

Fig 5. Forward Current vs. Forward Voltage at $T_C=25^\circ\text{C}$.

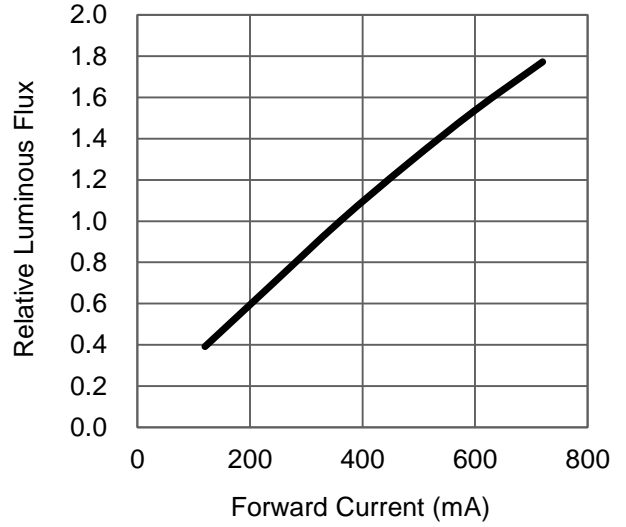

Fig 6. Forward Current vs. Relative Luminous Flux at $T_C=25^\circ\text{C}$.

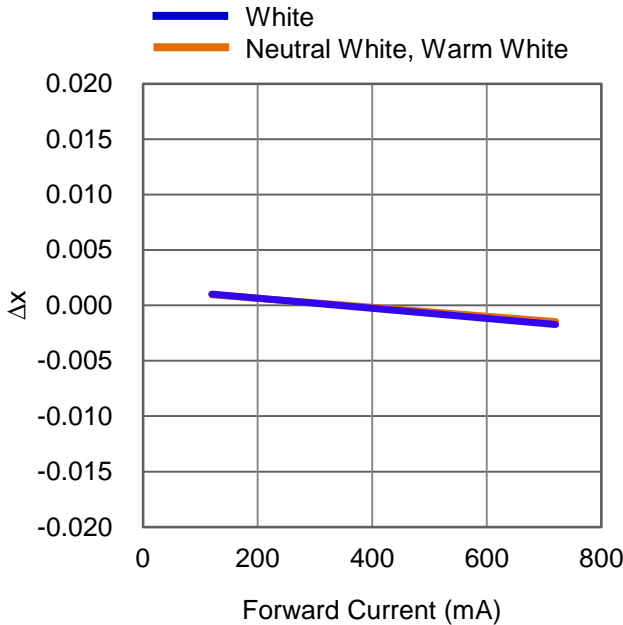

Fig 7. Forward Current vs. Chromaticity Coordinate Δx at $T_C=25^\circ\text{C}$.

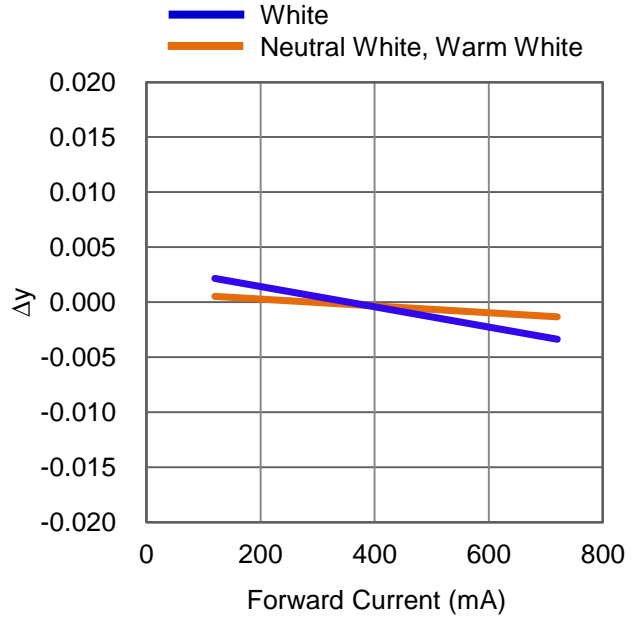

Fig 8. Forward Current vs. Chromaticity Coordinate Δy at $T_C=25^\circ\text{C}$.

Case Temperature vs. Junction Temperature Characteristics

T _c (°C)	T _j (°C)	
	360 (mA)	720 (mA)
0	18	40
5	23	45
10	28	50
15	33	55
20	38	60
25	43	65
30	48	70
35	53	75
40	58	80
45	63	85
50	68	90
55	73	95
60	78	100
65	83	105
70	88	110
75	93	115
80	98	120

Fig 9. Case Temperature vs. Junction Temperature at 360 、720mA.

Color Coordinate vs. Forward Current, $T_c = 25^\circ\text{C}$

White Binning Graphical Representation

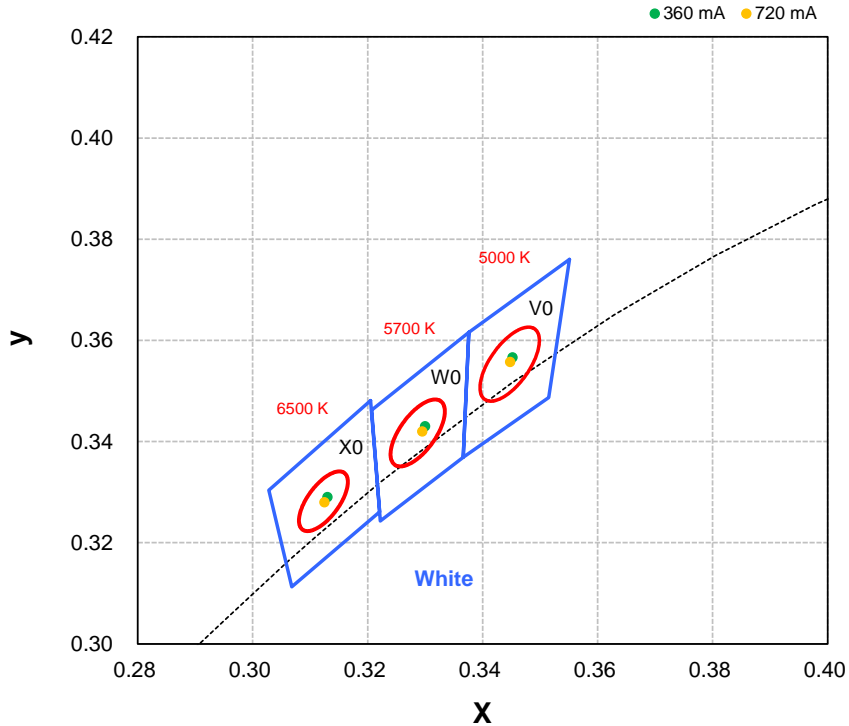

Neutral White Binning Graphical Representation

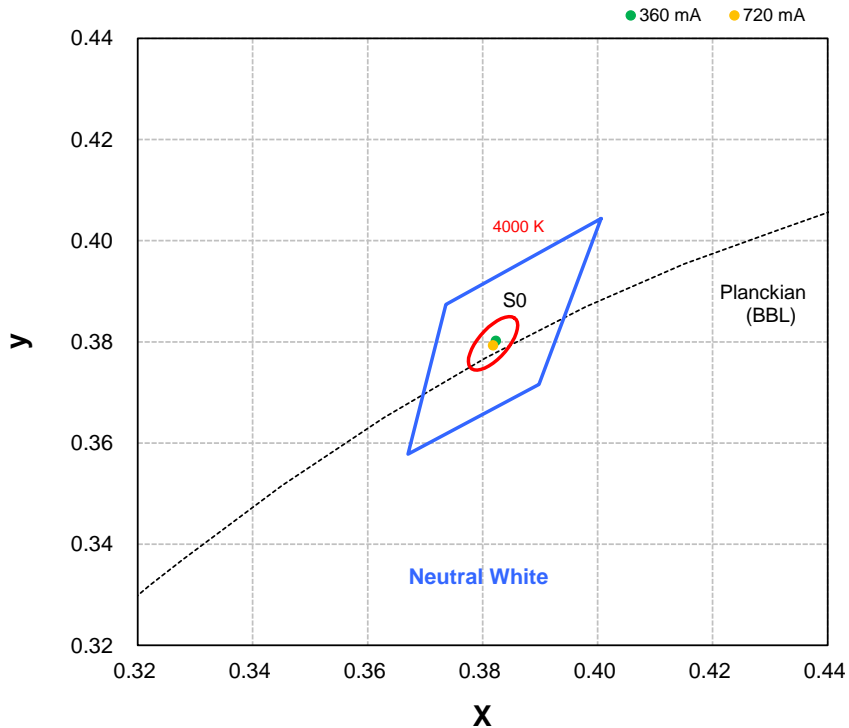

Color Coordinate vs. Forward Current, $T_c = 25^\circ\text{C}$

Warm White Binning Graphical Representation

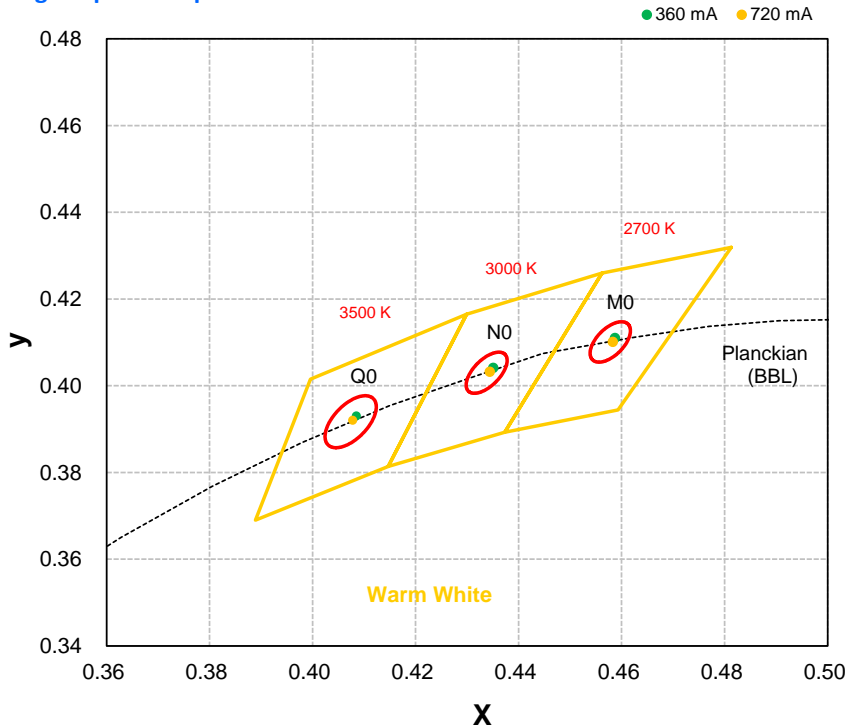

Typical Representative Spatial Radiation Pattern

Lambertian Radiation Pattern

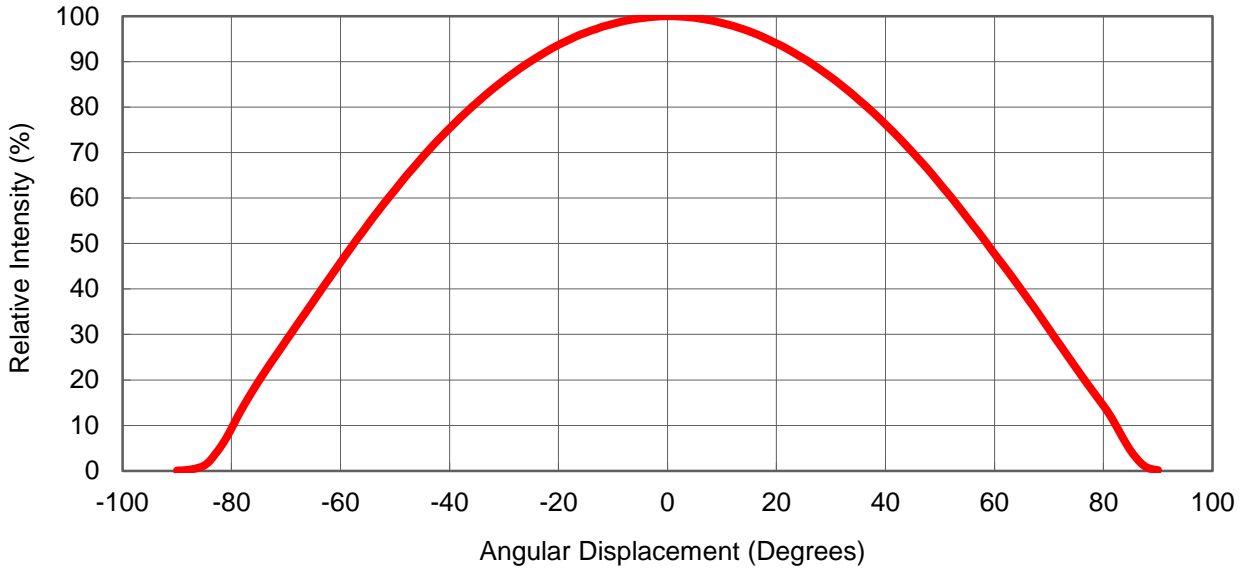

Polar Radiation Pattern

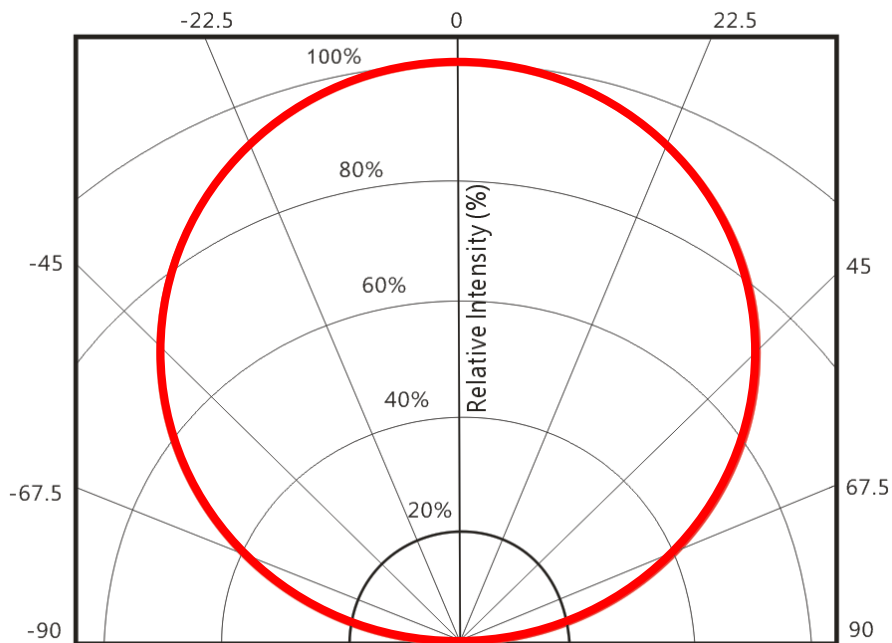

Packing Specifications

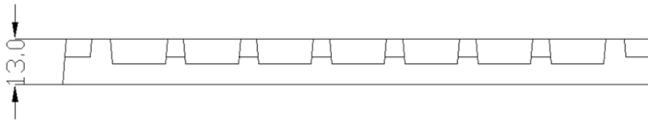
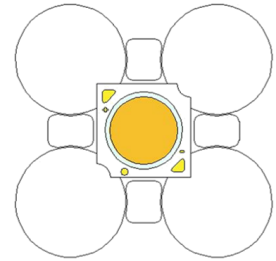
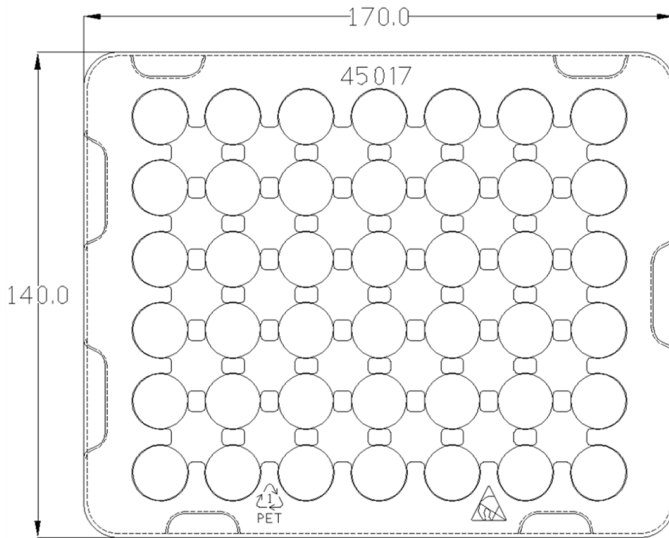

Product 30 pcs/tray

Notes:

1. Drawing not to scale.
2. All dimensions are in millimeters.
3. Unless otherwise indicated, tolerances are $\pm 0.20\text{mm}$.

Assembly note

Regarding the high power density of LED Array, it is strongly recommend to use thermal grease and screws.

In order to reduce thermal resistance at assembly, it is necessary to use TIM (thermal interface Material) uniformly and tighten screws on heatsink, otherwise the bad thermal resistance may cause the packages **burned out**.

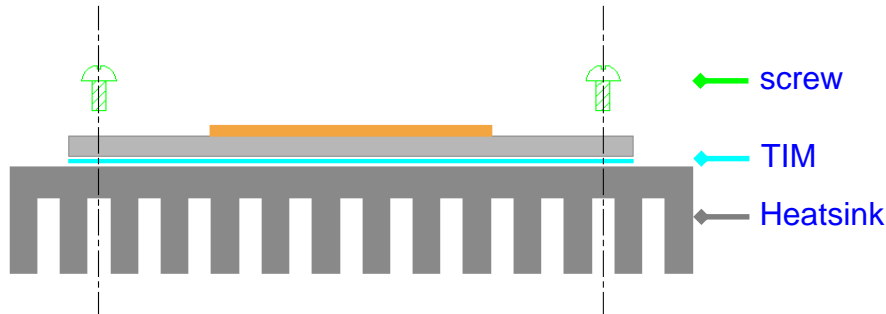

Fig 10. Reference assembly as fixing with screws

Limited Warranty : COB Light Engine Series

This limited warranty is provided by ProLight Opto described below (“Seller”) to you as the original purchaser of the LED lighting product that is identified on Seller’s invoice reflecting its original purchase (the “Product”). We warrant the identification as such on the invoice, will be free of defects in material and workmanship for a period of five (5) YEARS from the date of original purchase. This limited warranty excludes field labor and service charges related to the repair or replacement of the Product. Seller’s aggregate liability with respect to a defective product shall in any event be limited to the monies paid to seller for that defective product. The determination of whether the Product is defective shall be made by Seller in its sole discretion with consideration given to the overall performance of the Product. This limited warranty cannot be transferred to subsequent purchasers of the Product, provided that such Product is resold in new condition and in its original packaging. This limited warranty is void if the product is not used for the purpose for which it is designed.

Recommended Soldering Condition

- Please use lead free and “no clean ” solders.
- Soldering shall be implemented using a soldering tip at a temperature lower than 350 °C, and shall be finished within 3.5 seconds for each pad.
- During the soldering process, put the LEDs on materials whose conductivity is poor enough not to radiate heat of soldering.
- Properly solder tin wires before soldering them to LEDs.
- Avoid touching the silicone lens with the soldering iron.
- Please prevent flux from touching to the silicone lens.
- Please solder evenly on each pad.
- Contacts number of a soldering tip should be within twice for each pad.
- Next process of soldering should be carried out after the LEDs have return to ambient temperature.

*ProLight cannot guarantee if usage exceeds these recommended conditions.

Please use it after sufficient verification is carried out on your own risk if absolutely necessary.

Precaution for Use

- The modules light output are intense enough to cause injury to human eyes if viewed directly. Precautions must be taken to avoid looking directly at the modules with unprotected eyes.
- The modules are sensitive to electrostatic discharge. Appropriate ESD protection measures must be taken when working with the modules. Non-compliance with ESD protection measures may lead to damage or destruction of the product.
- Chemical solvents or cleaning agents must not be used to clean the modules. Mechanical stress on the Emitters must be avoided. It is best to use a soft brush, damp cloth or low-pressure compressed air.
- The products should be stored away from direct light in dry location.
- The appearance, specifications and flux bin of the product may be modified for improvement without notice. Please refer to the below website for the latest datasheets.
<http://www.prolightopto.com/>

Handling of Silicone Lens LEDs

Notes for handling of silicone lens LEDs

- Please do not use a force of over 0.3kgf impact or pressure on the silicone lens, otherwise it will cause a catastrophic failure.
- Avoid touching the silicone lens and the optical area of the COB Array especially by sharp tools such as Tweezers
- Avoid touching the silicone lens especially by sharp tools such as Tweezers.
- Avoid leaving fingerprints on the silicone lens.
- Please store the LEDs away from dusty areas or seal the product against dust.
- Please do not mold over the silicone lens with another resin. (epoxy, urethane, etc)



X-ON Electronics

Largest Supplier of Electrical and Electronic Components

Click to view similar products for [High Power LEDs - White](#) category:

Click to view products by [Prolight](#) manufacturer:

Other Similar products are found below :

[G42180-08](#) [B42180-08](#) [STW8Q2PA-R5-HA](#) [SZ5-M1-W0-00-V3/W2-AA](#) [LTPL-P00DWS57](#) [LZP-D0WW00-0000](#) [CLM-9-30-90-36-AC32-F4-3](#)
[SZ5-M1-WW-C8-V1/V3-FA](#) [XHP50B-00-0000-0D0HJ240H](#) [BXRC-27E2000-D-73](#) [BXRC-27G2000-D-73](#) [BXRC-30E1000-D-73](#) [BXRC-30G2000-D-73](#) [BXRC-40E1000-D-73](#) [BXRE-30G2000-B-73](#) [BXRE-30G2000-C-73](#) [BXRE-50C2001-C-74](#) [CXM-22-27-80-54-AC30-F4-3](#) [XHP50B-00-0000-0D0UH245G](#) [XHP50B-00-0000-0D0UG227H](#) [XHP50B-00-0000-0D0HJ245G](#) [MP-5050-8100-27-80](#) [MP-5050-6100-65-80](#) [MP-5050-6100-50-80](#) [MP-5050-6100-40-80](#) [MP-5050-6100-30-80](#) [MP-3020-3100-65-80](#) [MP-3020-3100-40-90](#) [MP-3014-1100-40-80](#) [MP-3014-1100-35-80](#) [MP-3014-1100-30-80](#) [MP-3014-1100-27-80](#) [CXM-22-30-80-54-AC30-F4-3](#) [MP-3014-1100-57-70](#) [LTW-2835SZK57](#) [BXEM-50C0000-0-000](#) [WW-WNA30TS-U1\(M1\)](#) [KW CSLPM2.CC-8L8M-4L8N](#) [KW CSLPM2.CC-8L8M-4O9Q](#) [KW DPLS32.SB-6H6J-E5P7-EG-Z264](#) [L1V1-507003V500000](#)
[CXM-22-35-80-36-AC10-F3-3](#) [KW3 CGLNM1.TG-Z6QF6-EBVFFCBB46-DFGA](#) [GWCS8PM1.PM-LSLU-A232-1](#) [JB5630AWT-H-H65EA0000-NZ000001](#) [XHP50B-00-0000-0D0UG430H](#) [CXM-22-35-90-54-AC40-F5-3](#) [CXM-22-35-80-54-AC40-F5-3](#) [OSM51206E1N-0.8T](#) [OSW43020C1C](#)