



PCF8523

Real-Time Clock (RTC) and calendar

Rev. 7 — 28 April 2015

Product data sheet

1. General description

The PCF8523 is a CMOS¹ Real-Time Clock (RTC) and calendar optimized for low power consumption. Data is transferred serially via the I²C-bus with a maximum data rate of 1 000 kbit/s. Alarm and timer functions are available with the possibility to generate a wake-up signal on an interrupt pin. An offset register allows fine-tuning of the clock. The PCF8523 has a backup battery switch-over circuit, which detects power failures and automatically switches to the battery supply when a power failure occurs.

For a selection of NXP Real-Time Clocks, see [Table 56 on page 68](#)

2. Features and benefits

- Provides year, month, day, weekday, hours, minutes, and seconds based on a 32.768 kHz quartz crystal
- Resolution: seconds to years
- Clock operating voltage: 1.0 V to 5.5 V
- Low backup current: typical 150 nA at $V_{DD} = 3.0$ V and $T_{amb} = 25$ °C
- 2 line bidirectional 1 MHz Fast-mode Plus (Fm+) I²C interface, read D1h, write D0h²
- Battery backup input pin and switch-over circuit
- Freely programmable timer and alarm with interrupt capability
- Selectable integrated oscillator load capacitors for $C_L = 7$ pF or $C_L = 12.5$ pF
- Oscillator stop detection function
- Internal Power-On Reset (POR)
- Open-drain interrupt or clock output pins
- Programmable offset register for frequency adjustment

3. Applications

- Time keeping application
- Battery powered devices
- Metering

1. The definition of the abbreviations and acronyms used in this data sheet can be found in [Section 22](#).
2. Devices with other I²C-bus slave addresses can be produced on request.



4. Ordering information

Table 1. Ordering information

| Type number | Package | | |
|-------------|----------|-------------------------------------------------------------------------------------------------------------|----------|
| | Name | Description | Version |
| PCF8523T | SO8 | plastic small outline package; 8 leads; body width 3.9 mm | SOT96-1 |
| PCF8523TK | HVSON8 | plastic thermal enhanced very thin small outline package; no leads; 8 terminals; body 4 × 4 × 0.85 mm | SOT909-1 |
| PCF8523TS | TSSOP14 | plastic thin shrink small outline package; 14 leads; body width 4.4 mm | SOT402-1 |
| PCF8523U | bare die | 12 bumps (6-6) | PCF8523U |

4.1 Ordering options

Table 2. Ordering options

| Product type number | Sales item (12NC) | Orderable part number | IC revision | Delivery form |
|---------------------|-------------------|-----------------------|-------------|--------------------------------------------------------------------------|
| PCF8523T/1 | 935293581118 | PCF8523T/1,118 | 1 | tape and reel, 13 inch |
| PCF8523TK/1 | 935293573118 | PCF8523TK/1,118 | 1 | tape and reel, 13 inch |
| PCF8523TS/1 | 935291196112 | PCF8523TS/1,112 | 1 | tube |
| | 935291196118 | PCF8523TS/1,118 | 1 | tape and reel, 13 inch |
| PCF8523U/12AA/1 | 935293887005 | PCF8523U/12AA/1,00 | 1 | chips with bumps ^[1] , sawn wafer on Film Frame Carrier (FFC) |

[1] Bump hardness see [Table 53](#).

Table 3. PCF8523U wafer information

| Type number | Wafer thickness | Wafer diameter | FFC for wafer size | Marking of bad die |
|-----------------|-----------------|----------------|--------------------|--------------------|
| PCF8523U/12AA/1 | 200 μm | 6 inch | 8 inch | wafer mapping |

5. Marking

Table 4. Marking codes

| Type number | Marking code |
|-----------------|--------------|
| PCF8523T/1 | 8523T |
| PCF8523TK/1 | 8523 |
| PCF8523TS/1 | 8523TS |
| PCF8523U/12AA/1 | PC8523-1 |

6. Block diagram

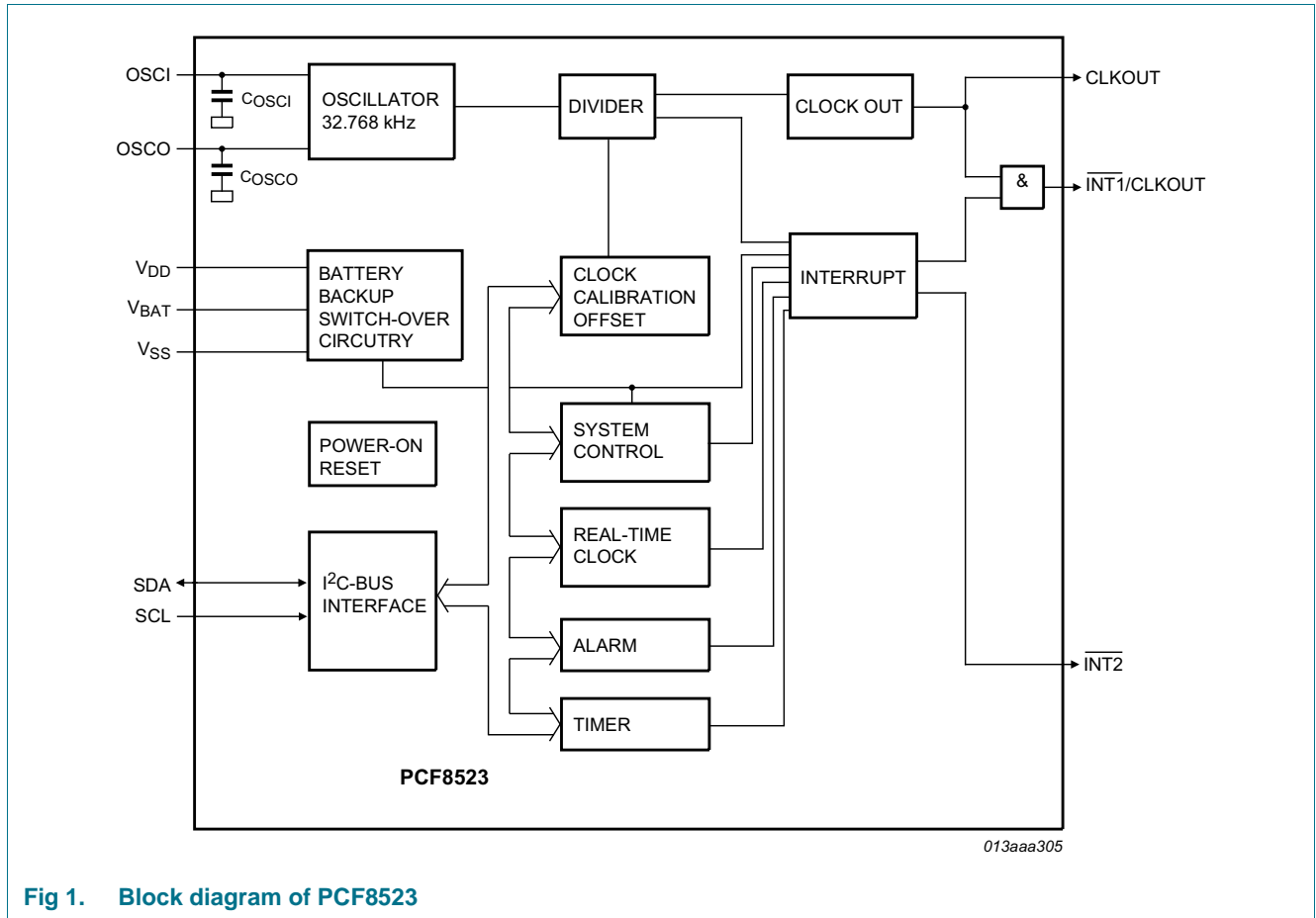
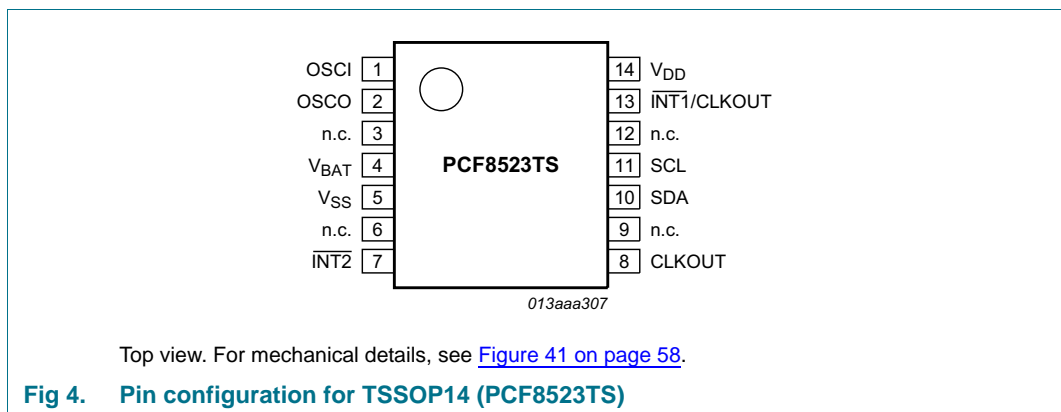
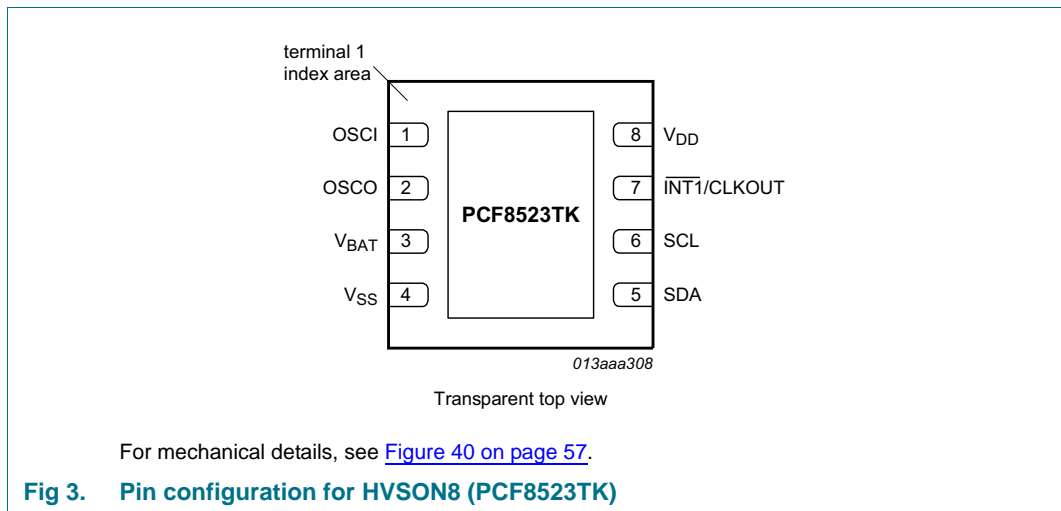
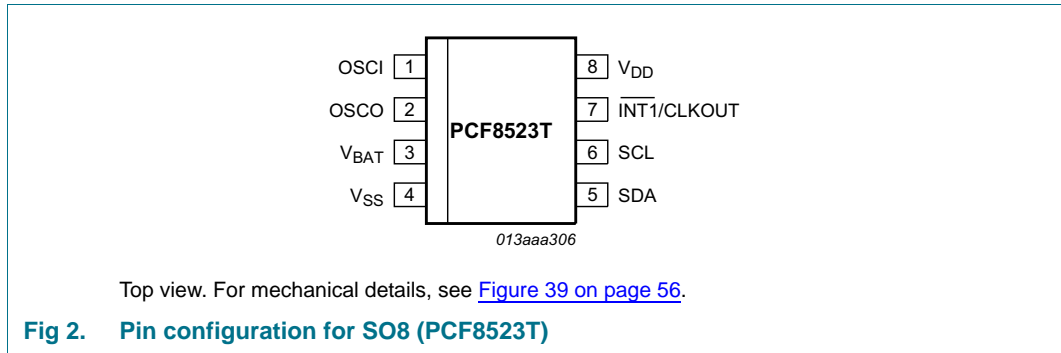
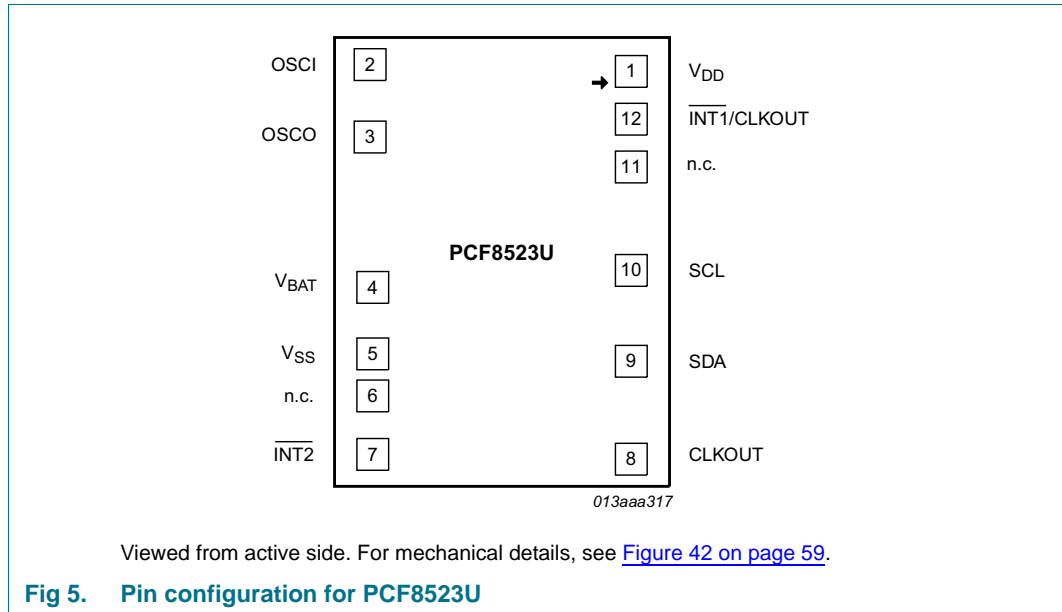

Fig 1. Block diagram of PCF8523

7. Pinning information

7.1 Pinning





7.2 Pin description

Table 5. Pin description

Input or input/output pins must always be at a defined level (V_{SS} or V_{DD}) unless otherwise specified.

| Symbol | Pin | | | | Type | Description |
|-----------------------------------------|----------------|--------------------|----------------------------|-------------------------|--------------|-----------------------------------------------------------------|
| | SO8 (PCF8523T) | HVSON8 (PCF8523TK) | TSSOP14 (PCF8523TS) | PCF8523U | | |
| OSCI | 1 | 1 | 1 | 2 | input | oscillator input; high-impedance node ^[1] |
| OSCO | 2 | 2 | 2 | 3 | output | oscillator output; high-impedance node ^[1] |
| n.c. | - | - | 3, 6, 9, 12 ^[2] | 6 and 11 ^[2] | - | not connected; do not connect and do not use it as feed through |
| V_{BAT} | 3 | 3 | 4 | 4 | supply | battery supply voltage |
| V_{SS} | 4 | 4 ^[3] | 5 | 5 ^[4] | supply | ground supply voltage |
| $\overline{INT2}$ | - | - | 7 | 7 | output | interrupt 2 (open-drain, active LOW) |
| CLKOUT ^[5] | - | - | 8 | 8 | output | clock output (open-drain) |
| SDA | 5 | 5 | 10 | 9 | input/output | serial data input/output |
| SCL | 6 | 6 | 11 | 10 | input | serial clock input |
| $\overline{INT1/CLKOUT}$ ^[5] | 7 | 7 | 13 | 12 | output | interrupt 1/clock output (open-drain) |
| V_{DD} | 8 | 8 | 14 | 1 | supply | supply voltage |

[1] Wire length between quartz and package should be minimized.

[2] For manufacturing tests only; do not connect it and do not use it.

[3] The die paddle (exposed pad) is connected to V_{SS} and should be electrically isolated.

[4] The substrate (rear side of the die) is connected to V_{SS} and should be electrically isolated.

[5] The PCF8523 can either drive the CLKOUT or the $\overline{INT1}$.

8. Functional description

The PCF8523 contains:

- 20 8-bit registers with an auto-incrementing address register
- An on-chip 32.768 kHz oscillator with two integrated load capacitors
- A frequency divider, which provides the source clock for the Real-Time Clock (RTC)
- A programmable clock output
- A 1 Mbit/s I²C-bus interface
- An offset register, which allows fine-tuning of the clock

All 20 registers are designed as addressable 8-bit registers although not all bits are implemented.

- The first three registers (memory address 00h, 01h, and 02h) are used as control and status registers
- The addresses 03h through 09h are used as counters for the clock function (seconds up to years)
- Addresses 0Ah through 0Dh define the alarm condition
- Address 0Eh defines the offset calibration
- Address 0Fh defines the clock-out mode and the addresses 10h and 12h the timer mode
- Addresses 11h and 13h are used for the timers

The registers Seconds, Minutes, Hours, Days, Weekdays, Months, and Years are all coded in Binary Coded Decimal (BCD) format. Other registers are either bit-wise or standard binary. When one of the RTC registers is read, the contents of all counters are frozen. Therefore, faulty reading of the clock and calendar during a carry condition is prevented.

The PCF8523 has a battery backup input pin and battery switch-over circuit. The battery switch-over circuit monitors the main power supply and switches automatically to the backup battery when a power failure condition is detected. Accurate timekeeping is maintained even when the main power supply is interrupted.

A battery low detection circuit monitors the status of the battery. When the battery voltage goes below a certain threshold value, a flag is set to indicate that the battery must be replaced soon. This ensures the integrity of the data during periods of battery backup.

8.1 Registers overview

The 20 registers of the PCF8523 are auto-incrementing after each read or write data byte up to register 13h. After register 13h, the auto-incrementing will wrap around to address 00h (see [Figure 6](#)).

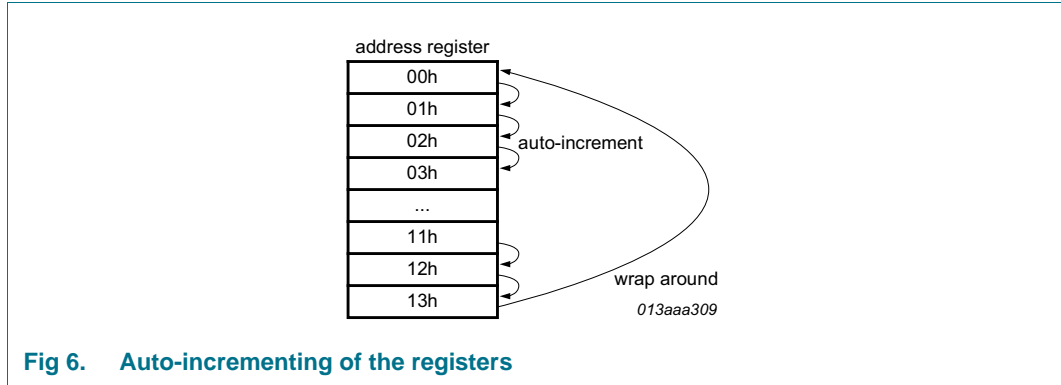

Fig 6. Auto-incrementing of the registers

Table 6. Registers overview

Bit positions labeled as - are not implemented and will return a 0 when read. Bit T must always be written with logic 0.

| Address | Register name | Bit | | | | | | | |
|--------------------------------|---------------|-----------------|------------------------|--------------------------------------|--------------------------------------|-------|------------------------|-------|-------|
| | | 7 | 6 | 5 | 4 | 3 | 2 | 1 | 0 |
| Control registers | | | | | | | | | |
| 00h | Control_1 | CAP_SEL | T | STOP | SR | 12_24 | SIE | AIE | CIE |
| 01h | Control_2 | WTAF | CTAF | CTBF | SF | AF | WTAIE | CTAIE | CTBIE |
| 02h | Control_3 | PM[2:0] | | | - | BSF | BLF | BSIE | BLIE |
| Time and date registers | | | | | | | | | |
| 03h | Seconds | OS | SECONDS (0 to 59) | | | | | | |
| 04h | Minutes | - | MINUTES (0 to 59) | | | | | | |
| 05h | Hours | - | - | AMPM | HOURS (1 to 12 in 12 hour mode) | | | | |
| | | | | HOURS (0 to 23 in 24 hour mode) | | | | | |
| 06h | Days | - | - | DAYS (1 to 31) | | | | | |
| 07h | Weekdays | - | - | - | - | - | WEEKDAYS (0 to 6) | | |
| 08h | Months | - | - | - | MONTHS (1 to 12) | | | | |
| 09h | Years | YEARS (0 to 99) | | | | | | | |
| Alarm registers | | | | | | | | | |
| 0Ah | Minute_alarm | AEN_M | MINUTE_ALARM (0 to 59) | | | | | | |
| 0Bh | Hour_alarm | AEN_H | - | AMPM | HOUR_ALARM (1 to 12 in 12 hour mode) | | | | |
| | | | - | HOUR_ALARM (0 to 23 in 24 hour mode) | | | | | |
| 0Ch | Day_alarm | AEN_D | - | DAY_ALARM (1 to 31) | | | | | |
| 0Dh | Weekday_alarm | AEN_W | - | - | - | - | WEEKDAY_ALARM (0 to 6) | | |
| Offset register | | | | | | | | | |
| 0Eh | Offset | MODE | OFFSET[6:0] | | | | | | |

Table 6. Registers overview ...continued

Bit positions labeled as - are not implemented and will return a 0 when read. Bit T must always be written with logic 0.

| Address | Register name | Bit | | | | | | | |
|-------------------------------------|-----------------|----------|----------|----------|---|---|----------|---|-----|
| | | 7 | 6 | 5 | 4 | 3 | 2 | 1 | 0 |
| CLOCKOUT and timer registers | | | | | | | | | |
| 0Fh | Tmr_CLKOUT_ctrl | TAM | TBM | COF[2:0] | | | TAC[1:0] | | TBC |
| 10h | Tmr_A_freq_ctrl | - | - | - | - | - | TAQ[2:0] | | |
| 11h | Tmr_A_reg | T_A[7:0] | | | | | | | |
| 12h | Tmr_B_freq_ctrl | - | TBW[2:0] | | | - | TBQ[2:0] | | |
| 13h | Tmr_B_reg | T_B[7:0] | | | | | | | |

8.2 Control and status registers

8.2.1 Register Control_1

Table 7. Control_1 - control and status register 1 (address 00h) bit description

| Bit | Symbol | Value | Description |
|-----|---------|---------------------|----------------------------------------------------------------------------------------------------------------------------------------------------------------|
| 7 | CAP_SEL | | internal oscillator capacitor selection for quartz crystals with a corresponding load capacitance |
| | | 0 ^[1] | 7 pF |
| | | 1 | 12.5 pF |
| 6 | T | 0 ^{[1][2]} | unused |
| 5 | STOP | 0 ^[1] | RTC time circuits running |
| | | 1 | RTC time circuits frozen; RTC divider chain flip-flops are asynchronously set logic 0; CLKOUT at 32.768 kHz, 16.384 kHz, or 8.192 kHz is still available |
| 4 | SR | 0 ^{[1][3]} | no software reset |
| | | 1 | initiate software reset |
| 3 | 12_24 | 0 ^[1] | 24 hour mode is selected |
| | | 1 | 12 hour mode is selected |
| 2 | SIE | 0 ^[1] | second interrupt disabled |
| | | 1 | second interrupt enabled |
| 1 | AIE | 0 ^[1] | alarm interrupt disabled |
| | | 1 | alarm interrupt enabled |
| 0 | CIE | 0 ^[1] | no correction interrupt generated |
| | | 1 | interrupt pulses are generated at every correction cycle (see Section 8.8) |

[1] Default value.

[2] Must always be written with logic 0.

[3] For a software reset, 01011000 (58h) must be sent to register Control_1 (see [Section 8.3](#)). Bit SR always returns 0 when read.

8.2.2 Register Control_2

Table 8. Control_2 - control and status register 2 (address 01h) bit description

| Bit | Symbol | Value | Description |
|-----|--------|------------------|-----------------------------------------------------------------------------------------------------------------|
| 7 | WTAF | 0 ^[1] | no watchdog timer A interrupt generated |
| | | 1 | flag set when watchdog timer A interrupt generated; flag is read-only and cleared by reading register Control_2 |
| 6 | CTAF | 0 ^[1] | no countdown timer A interrupt generated |
| | | 1 | flag set when countdown timer A interrupt generated; flag must be cleared to clear interrupt |
| 5 | CTBF | 0 ^[1] | no countdown timer B interrupt generated |
| | | 1 | flag set when countdown timer B interrupt generated; flag must be cleared to clear interrupt |
| 4 | SF | 0 ^[1] | no second interrupt generated |
| | | 1 | flag set when second interrupt generated; flag must be cleared to clear interrupt |
| 3 | AF | 0 ^[1] | no alarm interrupt generated |
| | | 1 | flag set when alarm triggered; flag must be cleared to clear interrupt |
| 2 | WTAIE | 0 ^[1] | watchdog timer A interrupt is disabled |
| | | 1 | watchdog timer A interrupt is enabled |
| 1 | CTAIE | 0 ^[1] | countdown timer A interrupt is disabled |
| | | 1 | countdown timer A interrupt is enabled |
| 0 | CTBIE | 0 ^[1] | countdown timer B interrupt is disabled |
| | | 1 | countdown timer B interrupt is enabled |

[1] Default value.

8.2.3 Register Control_3

Table 9. Control_3 - control and status register 3 (address 02h) bit description

| Bit | Symbol | Value | Description |
|--------|---------|---------------------------------------------|-----------------------------------------------------------------------------------|
| 7 to 5 | PM[2:0] | see Table 11 ^[1] | battery switch-over and battery low detection control |
| 4 | - | - | unused |
| 3 | BSF | 0 ^[2] | no battery switch-over interrupt generated |
| | | 1 | flag set when battery switch-over occurs; flag must be cleared to clear interrupt |
| 2 | BLF | 0 ^[2] | battery status ok |
| | | 1 | battery status low; flag is read-only |
| 1 | BSIE | 0 ^[2] | no interrupt generated from battery switch-over flag, BSF |
| | | 1 | interrupt generated when BSF is set |
| 0 | BLIE | 0 ^[2] | no interrupt generated from battery low flag, BLF |
| | | 1 | interrupt generated when BLF is set |

[1] Default value is 111.

[2] Default value.

8.3 Reset

A reset is automatically generated at power-on. A reset can also be initiated with the software reset command. Software reset command means setting bits 6, 4, and 3 in register Control_1 (00h) logic 1 and all other bits logic 0 by sending the bit sequence 01011000 (58h), see [Figure 7](#).

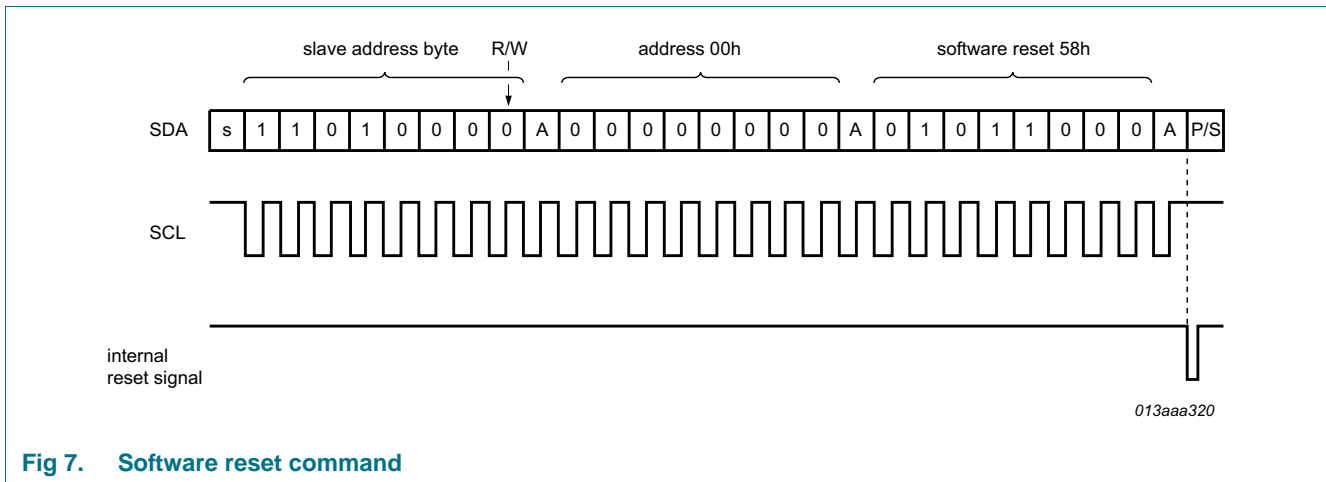

Fig 7. Software reset command

Table 10. Register reset values

Bits labeled X are undefined at power-on and unchanged by subsequent resets. Bits labeled - are not implemented.

| Address | Register name | Bit | | | | | | | |
|---------|-----------------|-----|---|---|---|---|---|---|---|
| | | 7 | 6 | 5 | 4 | 3 | 2 | 1 | 0 |
| 00h | Control_1 | 0 | 0 | 0 | 0 | 0 | 0 | 0 | 0 |
| 01h | Control_2 | 0 | 0 | 0 | 0 | 0 | 0 | 0 | 0 |
| 02h | Control_3 | 1 | 1 | 1 | - | 0 | 0 | 0 | 0 |
| 03h | Seconds | 1 | X | X | X | X | X | X | X |
| 04h | Minutes | - | X | X | X | X | X | X | X |
| 05h | Hours | - | - | X | X | X | X | X | X |
| 06h | Days | - | - | X | X | X | X | X | X |
| 07h | Weekdays | - | - | - | - | - | X | X | X |
| 08h | Months | - | - | - | X | X | X | X | X |
| 09h | Years | X | X | X | X | X | X | X | X |
| 0Ah | Minute_alarm | 1 | X | X | X | X | X | X | X |
| 0Bh | Hour_alarm | 1 | - | X | X | X | X | X | X |
| 0Ch | Day_alarm | 1 | - | X | X | X | X | X | X |
| 0Dh | Weekday_alarm | 1 | - | - | - | - | X | X | X |
| 0Eh | Offset | 0 | 0 | 0 | 0 | 0 | 0 | 0 | 0 |
| 0Fh | Tmr_CLKOUT_ctrl | 0 | 0 | 0 | 0 | 0 | 0 | 0 | 0 |
| 10h | Tmr_A_freq_ctrl | - | - | - | - | - | 1 | 1 | 1 |
| 11h | Tmr_A_reg | X | X | X | X | X | X | X | X |
| 12h | Tmr_B_freq_ctrl | - | 0 | 0 | 0 | - | 1 | 1 | 1 |
| 13h | Tmr_B_reg | X | X | X | X | X | X | X | X |

After reset, the following mode is entered:

- 32.768 kHz CLKOUT active
- 24 hour mode is selected
- Register Offset is set logic 0
- No alarms set
- Timers disabled
- No interrupts enabled
- Battery switch-over is disabled
- Battery low detection is disabled
- 7 pF of internal oscillator capacitor selected

8.4 Interrupt function

Active low interrupt signals are available at pin $\overline{\text{INT1/CLKOUT}}$ and $\overline{\text{INT2}}$. Pin $\overline{\text{INT1/CLKOUT}}$ has both functions of $\overline{\text{INT1}}$ and $\overline{\text{CLKOUT}}$ combined, that is that either the $\overline{\text{CLKOUT}}$ or the $\overline{\text{INT1}}$ can be used. Therefore the usage of $\overline{\text{INT1}}$ requires that $\overline{\text{CLKOUT}}$ is disabled.

$\overline{\text{INT1}}$ Interrupt output may be sourced from different places:

- Second timer
- Timer A
- Timer B
- Alarm
- Battery switch-over
- Battery low detection
- Clock offset correction pulse

$\overline{\text{INT2}}$ interrupt output is sourced only from timer B:

The control bit TAM (register Tmr_CLKOUT_ctrl) is used to configure whether the interrupts generated from the second interrupt timer and timer A are pulsed signals or a permanently active signal. The control bit TBM (register Tmr_CLKOUT_ctrl) is used to configure whether the interrupt generated from timer B is a pulsed signal or a permanently active signal. All the other interrupt sources generate a permanently active interrupt signal, which follows the status of the corresponding flags.

- The flags SF, CTAF, CTBF, AF, and BSF can be cleared by using the interface
- WTAF is read only. Reading of the register Control_2 (01h) automatically resets WTAF (WTAF = 0) and clears the interrupt
- The flag BLF is read only. It is cleared automatically from the battery low detection circuit when the battery is replaced

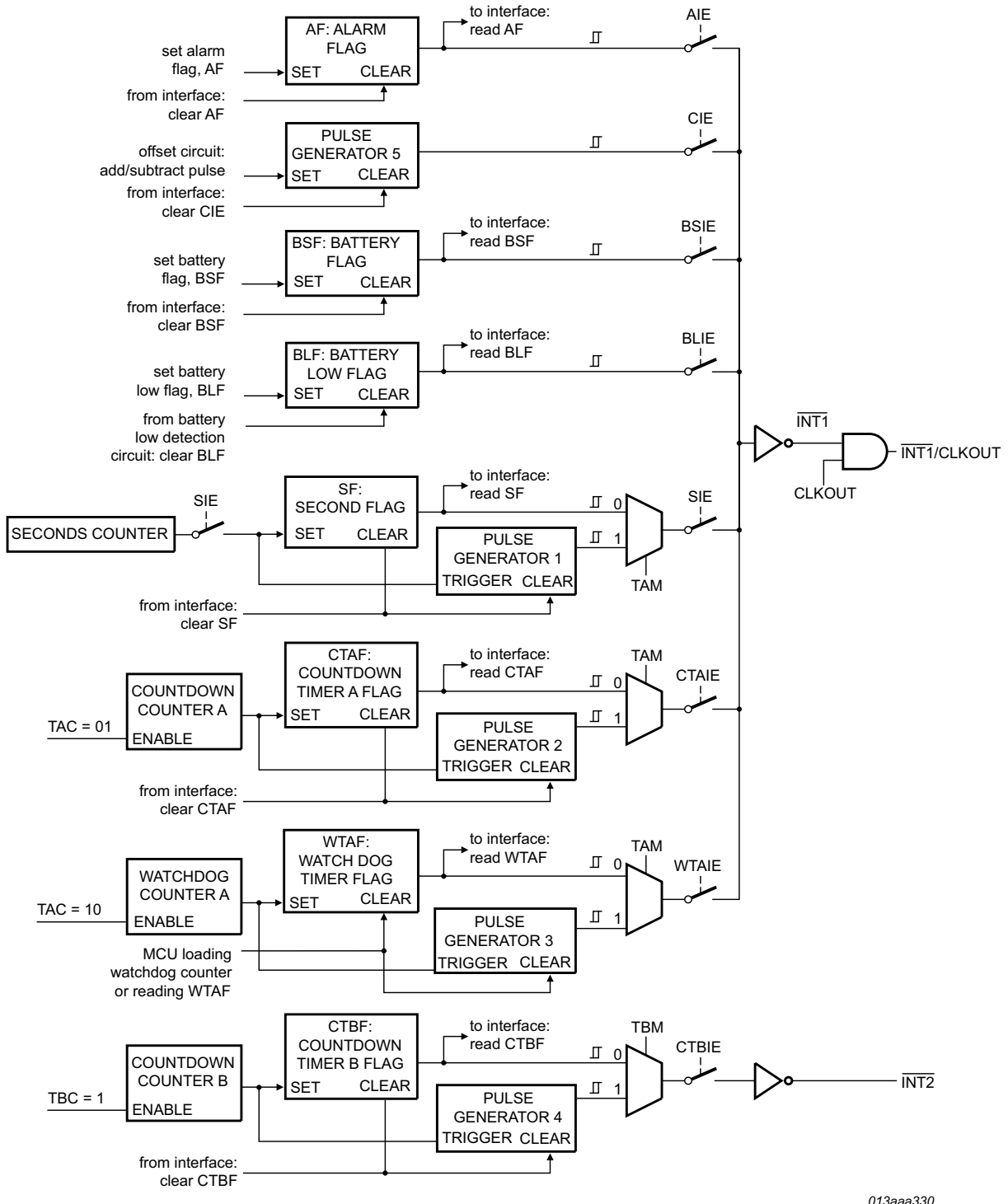

013aaa330

When SIE, CTBIE, WTAIE, CTBIE, AIE, CIE, BSIE, BLIE, and clock-out are disabled, then $\overline{\text{INT1}}$ remains high-impedance. When CTBIE is disabled, then INT2 remains high-impedance.

Fig 8. Interrupt block diagram

8.5 Power management functions

The PCF8523 has two power supply pins:

- V_{DD} - the main power supply input pin
- V_{BAT} - the battery backup input pin

The PCF8523 has two power management functions implemented:

- Battery switch-over function
- Battery low detection function

The power management functions are controlled by the control bits PM[2:0] in register Control_3 (02h):

Table 11. Power management function control bits

| PM[2:0] | Function |
|------------------------|------------------------------------------------------------------------------------------------------------------------------|
| 000 | battery switch-over function is enabled in standard mode; battery low detection function is enabled |
| 001 | battery switch-over function is enabled in direct switching mode; battery low detection function is enabled |
| 010,011 ^[1] | battery switch-over function is disabled - only one power supply (V_{DD}); battery low detection function is enabled |
| 100 | battery switch-over function is enabled in standard mode; battery low detection function is disabled |
| 101 | battery switch-over function is enabled in direct switching mode; battery low detection function is disabled |
| 110 | not allowed |
| 111 ^{[2][3]} | battery switch-over function is disabled - only one power supply (V_{DD}); battery low detection function is disabled |

[1] When the battery switch-over function is disabled, the PCF8523 works only with the power supply V_{DD} .

[2] When the battery switch-over function is disabled, the PCF8523 works only with the power supply V_{DD} and the battery low detection function is disabled. V_{BAT} must be put to V_{DD} .

[3] Default value.

8.5.1 Standby mode

When the device is first powered up from the battery (V_{BAT}) but without a main supply (V_{DD}), the PCF8523 automatically enters the standby mode. In standby mode, the PCF8523 does not draw any power from the backup battery until the device is powered up from the main power supply V_{DD} . Thereafter, the device switches over to battery backup mode whenever the main power supply V_{DD} is lost.

It is also possible to enter into standby mode when the chip is already supplied by the main power supply V_{DD} and a backup battery is connected. To enter the standby mode, the power management control bits PM[2:0] have to be set logic 111. Then the main power supply V_{DD} must be removed. As a result of it, the PCF8523 enters the standby mode and does not draw any current from the backup battery before it is powered up again from main supply V_{DD} .

8.5.2 Battery switch-over function

The PCF8523 has a backup battery switch-over circuit. It monitors the main power supply V_{DD} and switches automatically to the backup battery when a power failure condition is detected.

One of two operation modes can be selected:

- **Standard mode:** the power failure condition happens when:
 $V_{DD} < V_{BAT}$ AND $V_{DD} < V_{th(sw)bat}$
- **Direct switching mode:** the power failure condition happens when $V_{DD} < V_{BAT}$.
Direct switching from V_{DD} to V_{BAT} without requiring V_{DD} to drop below $V_{th(sw)bat}$

$V_{th(sw)bat}$ is the battery switch threshold voltage. Typical value is 2.5 V.

Generation of interrupts from the battery switch-over is controlled via the BSIE bit (see register Control_2). If BSIE is enabled, the INT1 follows the status of bit BLF (register Control_3). Clearing BLF immediately clears INT1.

When a power failure condition occurs and the power supply switches to the battery, the following sequence occurs:

1. The battery switch flag BSF (register Control_3) is set logic 1
2. An interrupt is generated if the control bit BSIE (register Control_3) is enabled

The battery switch flag BSF can be cleared by using the interface after the power supply has switched to V_{DD} . It must be cleared to clear the interrupt.

The interface is disabled in battery backup operation:

- Interface inputs are not recognized, preventing extraneous data being written to the device
- Interface outputs are high-impedance

8.5.2.1 Standard mode

If $V_{DD} > V_{BAT}$ OR $V_{DD} > V_{th(sw)bat}$, the internal power supply is V_{DD} .

If $V_{DD} < V_{BAT}$ AND $V_{DD} < V_{th(sw)bat}$, the internal power supply is V_{BAT} .

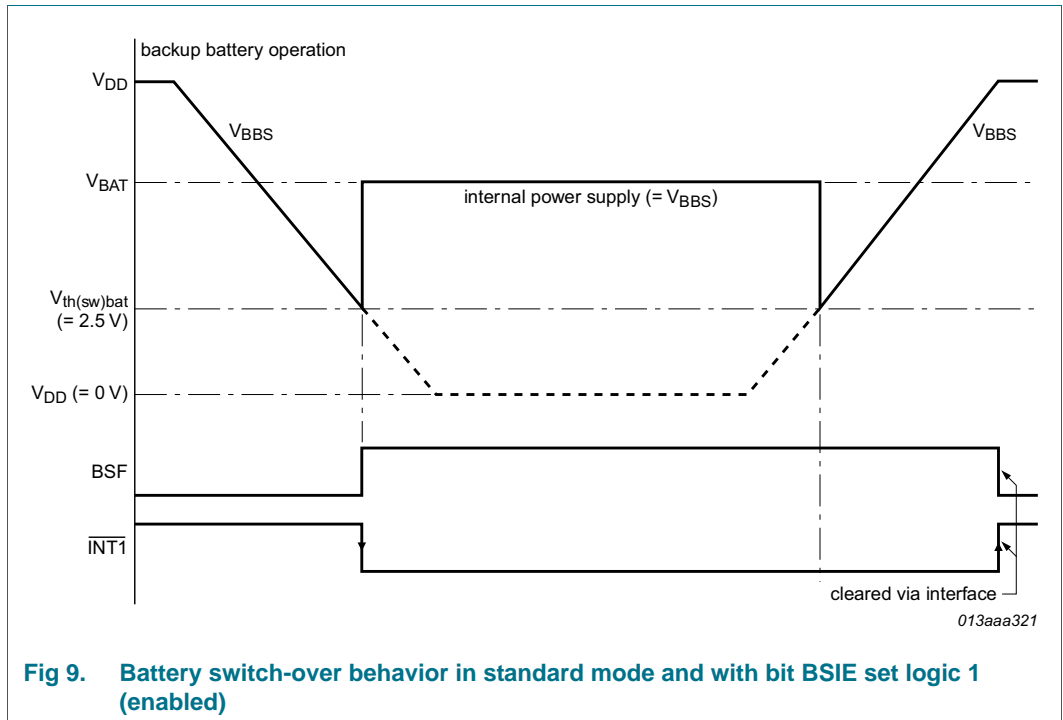

Fig 9. Battery switch-over behavior in standard mode and with bit BSIE set logic 1 (enabled)

8.5.2.2 Direct switching mode

If $V_{DD} > V_{BAT}$ the internal power supply is V_{DD} .

If $V_{DD} < V_{BAT}$ the internal power supply is V_{BAT} .

The direct switching mode is useful in systems where V_{DD} is higher than V_{BAT} at all times (for example, $V_{DD} = 5\text{ V}$, $V_{BAT} = 3.5\text{ V}$). If the V_{DD} and V_{BAT} values are similar (for example, $V_{DD} = 3.3\text{ V}$, $V_{BAT} \geq 3.0\text{ V}$), the direct switching mode is not recommended. In direct switching mode, the power consumption is reduced compared to the standard mode because the monitoring of V_{DD} and $V_{th(sw)bat}$ is not performed.

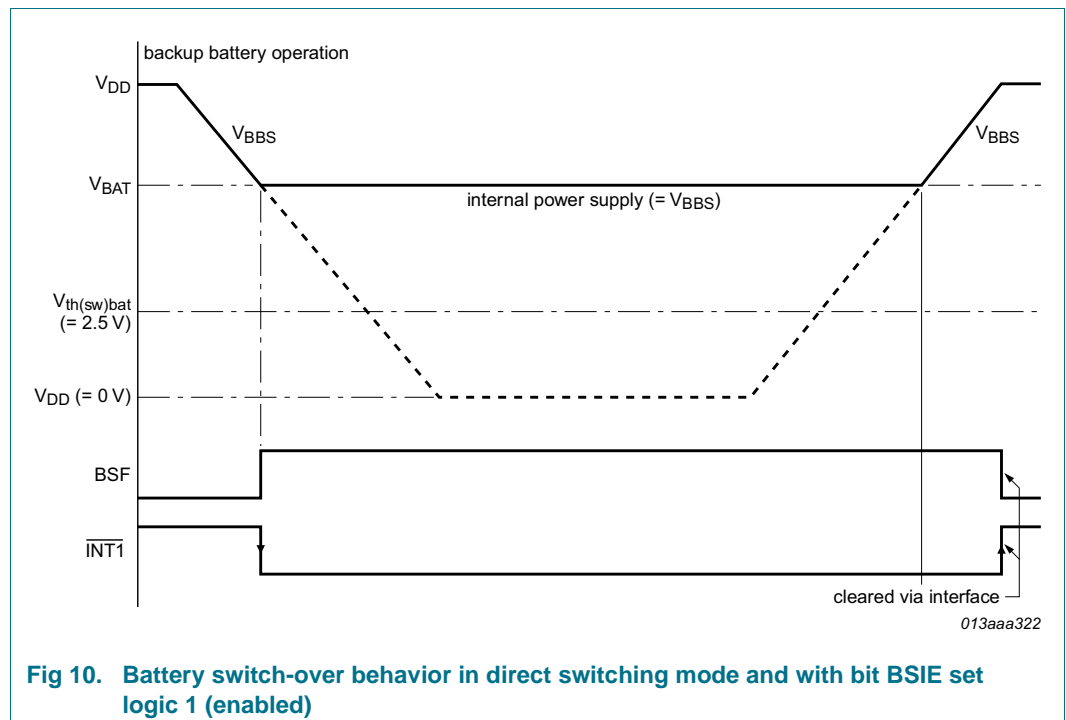

Fig 10. Battery switch-over behavior in direct switching mode and with bit BSIE set logic 1 (enabled)

8.5.2.3 Battery switch-over disabled, only one power supply (V_{DD})

When the battery switch-over function is disabled:

- The power supply is applied on the V_{DD} pin
- The V_{BAT} pin must be connected to V_{DD}
- The battery flag (BSF) is always logic 0

8.5.3 Battery low detection function

The PCF8523 has a battery low detection circuit, which monitors the status of the battery V_{BAT} .

Generation of interrupts from the battery low detection is controlled via bit BLIE (register Control_3). If BLIE is enabled, the INT1 follows the status of bit BLF (register Control_3).

When V_{BAT} drops below the threshold value $V_{th(bat)low}$ (typically 2.5 V), the BLF flag (register Control_3) is set to indicate that the battery is low and that it must be replaced. Monitoring of the battery voltage also occurs during battery operation.

An unreliable battery does not ensure data integrity during periods of backup battery operation.

When V_{BAT} drops below the threshold value $V_{th(bat)low}$, the following sequence occurs (see [Figure 11](#)):

1. The battery low flag BLF is set logic 1
2. An interrupt is generated if the control bit BLIE (register Control_3) is enabled. The interrupt remains active until the battery is replaced (BLF set logic 0) or when bit BLIE is disabled (BLIE set logic 0)
3. The flag BLF (register Control_3) remains logic 1 until the battery is replaced. BLF cannot be cleared using the interface. It is cleared automatically by the battery low detection circuit when the battery is replaced

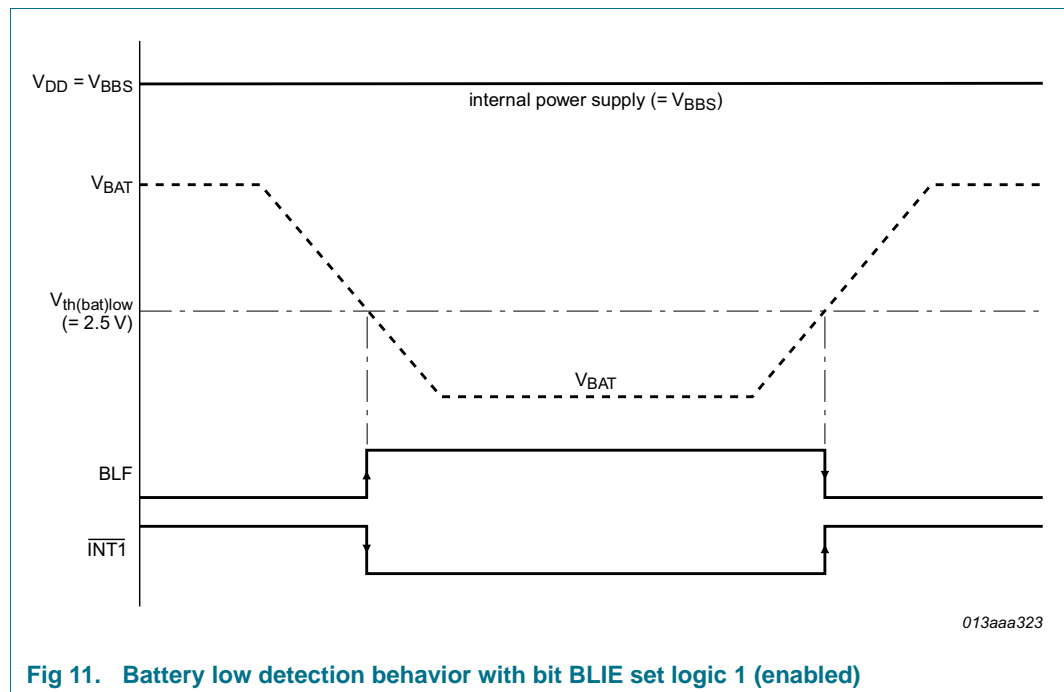

Fig 11. Battery low detection behavior with bit BLIE set logic 1 (enabled)

8.6 Time and date registers

Most of these registers are coded in the Binary Coded Decimal (BCD) format. BCD is used to simplify application use. An example is shown for the array SECONDS in [Table 13](#).

8.6.1 Register Seconds

Table 12. Seconds - seconds and clock integrity status register (address 03h) bit description

| Bit | Symbol | Value | Place value | Description |
|--------|---------|------------------|-------------|-------------------------------------------------------------------------------|
| 7 | OS | 0 | - | clock integrity is guaranteed |
| | | 1 ^[1] | - | clock integrity is not guaranteed; oscillator has stopped or been interrupted |
| 6 to 4 | SECONDS | 0 to 5 | ten's place | actual seconds coded in BCD format |
| 3 to 0 | | 0 to 9 | unit place | |

[1] Start-up value.

Table 13. SECONDS coded in BCD format

| Seconds value in decimal | Upper-digit (ten's place) | | | Digit (unit place) | | | |
|--------------------------|---------------------------|---|---|--------------------|---|---|---|
| | Bit | | | Bit | | | |
| | 6 | 5 | 4 | 3 | 2 | 1 | 0 |
| 00 | 0 | 0 | 0 | 0 | 0 | 0 | 0 |
| 01 | 0 | 0 | 0 | 0 | 0 | 0 | 1 |
| 02 | 0 | 0 | 0 | 0 | 0 | 1 | 0 |
| : | : | : | : | : | : | : | : |
| 09 | 0 | 0 | 0 | 1 | 0 | 0 | 1 |
| 10 | 0 | 0 | 1 | 0 | 0 | 0 | 0 |
| : | : | : | : | : | : | : | : |
| 58 | 1 | 0 | 1 | 1 | 0 | 0 | 0 |
| 59 | 1 | 0 | 1 | 1 | 0 | 0 | 1 |

8.6.1.1 Oscillator STOP flag

The OS flag is set whenever the oscillator is stopped (see [Figure 12](#)). The flag remains set until cleared by using the interface. When the oscillator is not running, then the OS flag cannot be cleared. This method can be used to monitor the oscillator.

The oscillator may be stopped, for example, by grounding one of the oscillator pins, OSC1 or OSC0. The oscillator is also considered to be stopped during the time between power-on and stable crystal resonance. This time may be in a range of 200 ms to 2 s, depending on crystal type, temperature, and supply voltage. At power-on, the OS flag is always set.

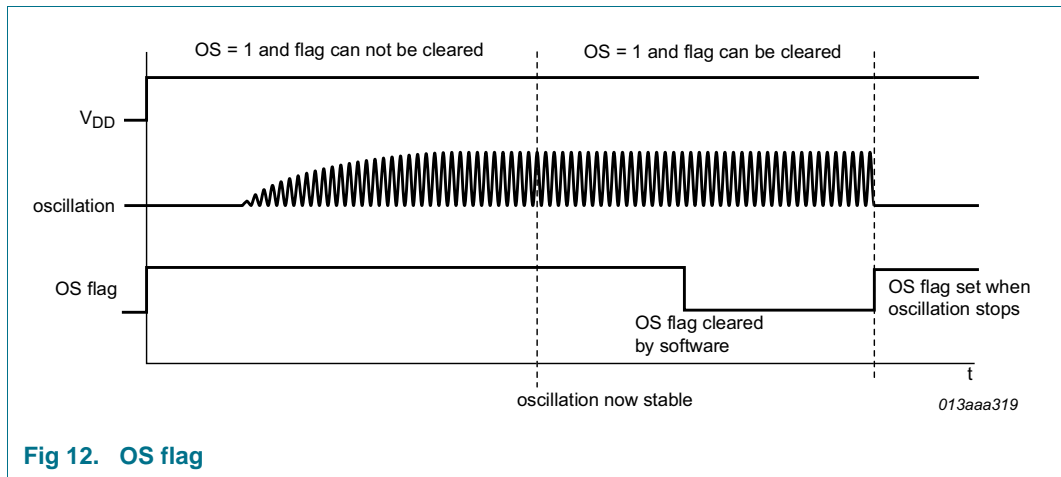

Fig 12. OS flag

8.6.2 Register Minutes

Table 14. Minutes - minutes register (address 04h) bit description

| Bit | Symbol | Value | Place value | Description |
|--------|---------|--------|-------------|------------------------------------|
| 7 | - | - | - | unused |
| 6 to 4 | MINUTES | 0 to 5 | ten's place | actual minutes coded in BCD format |
| 3 to 0 | | 0 to 9 | unit place | |

8.6.3 Register Hours

Table 15. Hours - hours register (address 05h) bit description

| Bit | Symbol | Value | Place value | Description |
|-----------------------------------|--------|--------|-------------|--------------------------------------------------|
| 7 to 6 | - | - | - | unused |
| 12 hour mode^[1] | | | | |
| 5 | AMPM | 0 | - | indicates AM |
| | | 1 | - | indicates PM |
| 4 | HOURS | 0 to 1 | ten's place | actual hours in 12 hour mode coded in BCD format |
| 3 to 0 | | 0 to 9 | unit place | |
| 24 hour mode^[1] | | | | |
| 5 to 4 | HOURS | 0 to 2 | ten's place | actual hours in 24 hour mode coded in BCD format |
| 3 to 0 | | 0 to 9 | unit place | |

[1] Hour mode is set by bit 12_24 in register Control_1 (see Table 7).

8.6.4 Register Days

Table 16. Days - days register (address 06h) bit description

| Bit | Symbol | Value | Place value | Description |
|--------|---------------------|--------|-------------|--------------------------------|
| 7 to 6 | - | - | - | unused |
| 5 to 4 | DAYS ^[1] | 0 to 3 | ten's place | actual day coded in BCD format |
| 3 to 0 | | 0 to 9 | unit place | |

[1] If the year counter contains a value, which is exactly divisible by 4 (including the year 00), the PCF8523 compensates for leap years by adding a 29th day to February.

8.6.5 Register Weekdays

Table 17. Weekdays - weekdays register (address 07h) bit description

| Bit | Symbol | Value | Description |
|--------|----------|--------|-----------------------------------------------------|
| 7 to 3 | - | - | unused |
| 2 to 0 | WEEKDAYS | 0 to 6 | actual weekday, values see Table 18 |

Table 18. Weekday assignments

| Day ^[1] | Bit | | |
|--------------------|-----|---|---|
| | 2 | 1 | 0 |
| Sunday | 0 | 0 | 0 |
| Monday | 0 | 0 | 1 |
| Tuesday | 0 | 1 | 0 |
| Wednesday | 0 | 1 | 1 |
| Thursday | 1 | 0 | 0 |
| Friday | 1 | 0 | 1 |
| Saturday | 1 | 1 | 0 |

[1] Definition may be reassigned by the user.

8.6.6 Register Months

Table 19. Months - months register (address 08h) bit description

| Bit | Symbol | Value | Place value | Description |
|--------|--------|--------|-------------|----------------------------------------------------------------------------|
| 7 to 5 | - | - | - | unused |
| 4 | MONTHS | 0 to 1 | ten's place | actual month coded in BCD format; assignments see Table 20 |
| 3 to 0 | | 0 to 9 | unit place | |

Table 20. Month assignments in BCD format

| Month | Upper-digit (ten's place) | | Digit (unit place) | | |
|-----------|---------------------------|---|--------------------|---|---|
| | Bit | | Bit | | |
| | 4 | 3 | 2 | 1 | 0 |
| January | 0 | 0 | 0 | 0 | 1 |
| February | 0 | 0 | 0 | 1 | 0 |
| March | 0 | 0 | 0 | 1 | 1 |
| April | 0 | 0 | 1 | 0 | 0 |
| May | 0 | 0 | 1 | 0 | 1 |
| June | 0 | 0 | 1 | 1 | 0 |
| July | 0 | 0 | 1 | 1 | 1 |
| August | 0 | 1 | 0 | 0 | 0 |
| September | 0 | 1 | 0 | 0 | 1 |
| October | 1 | 0 | 0 | 0 | 0 |
| November | 1 | 0 | 0 | 0 | 1 |
| December | 1 | 0 | 0 | 1 | 0 |

8.6.7 Register Years

Table 21. Years - years register (09h) bit description

| Bit | Symbol | Value | Place value | Description |
|--------|--------|--------|-------------|---------------------------------|
| 7 to 4 | YEARS | 0 to 9 | ten's place | actual year coded in BCD format |
| 3 to 0 | | 0 to 9 | unit place | |

8.6.8 Data flow of the time function

Figure 13 shows the data flow and data dependencies starting from the 1 Hz clock tick.

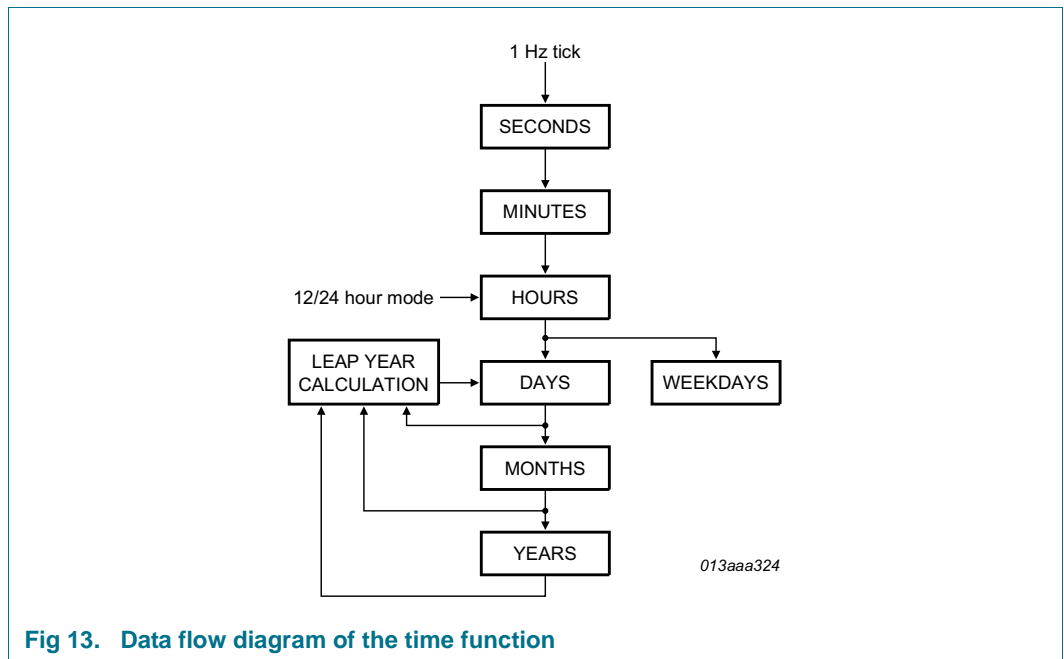

Fig 13. Data flow diagram of the time function

During read/write operations, the time counting circuits (memory locations 03h through 09h) are blocked.

The blocking prevents:

- Faulty reading of the clock and calendar during a carry condition
- Incrementing the time registers during the read cycle

After the read/write-access is completed, the time circuit is released again and any pending request to increment the time counters that occurred during the read/write access is serviced. A maximum of one request can be stored; therefore, all accesses must be completed within 1 second (see Figure 14).

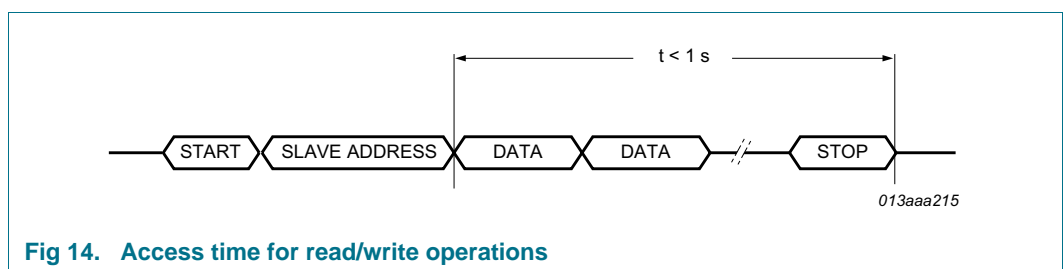

Fig 14. Access time for read/write operations

Because of this method, it is very important to make a read or write access in one go, that is, setting or reading seconds through to years should be made in one single access. Failing to comply with this method could result in the time becoming corrupted.

As an example, if the time (seconds through to hours) is set in one access and then in a second access the date is set, it is possible that the time will increment between the two accesses. A similar problem exists when reading. A rollover may occur between reads thus giving the minutes from one moment and the hours from the next.

8.7 Alarm registers

The registers at addresses 0Ah through 0Dh contain the alarm information.

8.7.1 Register Minute_alarm

Table 22. Minute_alarm - minute alarm register (address 0Ah) bit description

| Bit | Symbol | Value | Place value | Description |
|--------|--------------|------------------|-------------|----------------------------------------------|
| 7 | AEN_M | 0 | - | minute alarm is enabled |
| | | 1 ^[1] | - | minute alarm is disabled |
| 6 to 4 | MINUTE_ALARM | 0 to 5 | ten's place | minute alarm information coded in BCD format |
| 3 to 0 | | 0 to 9 | unit place | |

[1] Default value.

8.7.2 Register Hour_alarm

Table 23. Hour_alarm - hour alarm register (address 0Bh) bit description

| Bit | Symbol | Value | Place value | Description |
|-----------------------------------|------------|------------------|-------------|------------------------------------------------------------|
| 7 | AEN_H | 0 | - | hour alarm is enabled |
| | | 1 ^[1] | - | hour alarm is disabled |
| 6 | - | - | - | unused |
| 12 hour mode^[2] | | | | |
| 5 | AMPM | 0 | - | indicates AM |
| | | 1 | - | indicates PM |
| 4 | HOUR_ALARM | 0 to 1 | ten's place | hour alarm information in 12 hour mode coded in BCD format |
| 3 to 0 | | 0 to 9 | unit place | |
| 24 hour mode^[2] | | | | |
| 5 to 4 | HOURS | 0 to 2 | ten's place | hour alarm information in 24 hour mode coded in BCD format |
| 3 to 0 | | 0 to 9 | unit place | |

[1] Default value.

[2] Hour mode is set by bit 12_24 in register Control_1 (see [Table 7](#)).

8.7.3 Register Day_alarm

Table 24. Day_alarm - day alarm register (address 0Ch) bit description

| Bit | Symbol | Value | Place value | Description |
|--------|-----------|------------------|-------------|-------------------------------------------|
| 7 | AEN_D | 0 | - | day alarm is enabled |
| | | 1 ^[1] | - | day alarm is disabled |
| 6 | - | - | - | unused |
| 5 to 4 | DAY_ALARM | 0 to 3 | ten's place | day alarm information coded in BCD format |
| 3 to 0 | | 0 to 9 | unit place | |

[1] Default value.

8.7.4 Register Weekday_alarm

Table 25. Weekday_alarm - weekday alarm register (address 0Dh) bit description

| Bit | Symbol | Value | Description |
|--------|---------------|------------------|---------------------------|
| 7 | AEN_W | 0 | weekday alarm is enabled |
| | | 1 ^[1] | weekday alarm is disabled |
| 6 to 3 | - | - | unused |
| 2 to 0 | WEEKDAY_ALARM | 0 to 6 | weekday alarm information |

[1] Default value.

8.7.5 Alarm flag

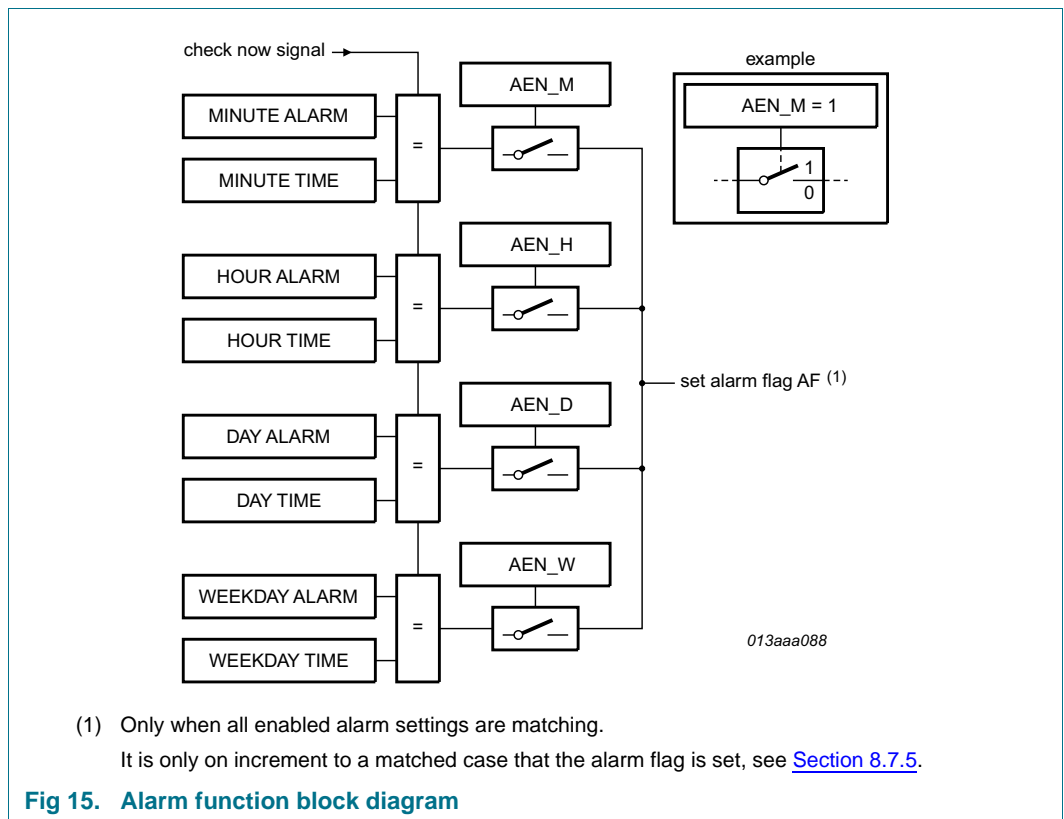

When one or several alarm registers are loaded with a valid minute, hour, day, or weekday value and its corresponding alarm enable bit (AEN_x) is logic 0, then that information is compared with the current minute, hour, day, and weekday value. When all enabled comparisons first match, the alarm flag, AF (register Control_2), is set logic 1.

The generation of interrupts from the alarm function is controlled via bit AIE (register Control_1). If bit AIE is enabled, then the $\overline{\text{INT1}}$ pin follows the condition of bit AF. AF remains set until cleared by the interface. Once AF has been cleared, it will only be set again when the time increments to match the alarm condition once more. Alarm registers, which have their AEN_x bit logic 1 are ignored. The generation of interrupts from the alarm function is described more detailed in [Section 8.4](#).

[Table 26](#) and [Table 27](#) show an example for clearing bit AF. Clearing the flag is made by a write command, therefore bits 2, 1, and 0 must be re-written with their previous values. Repeatedly re-writing these bits has no influence on the functional behavior.

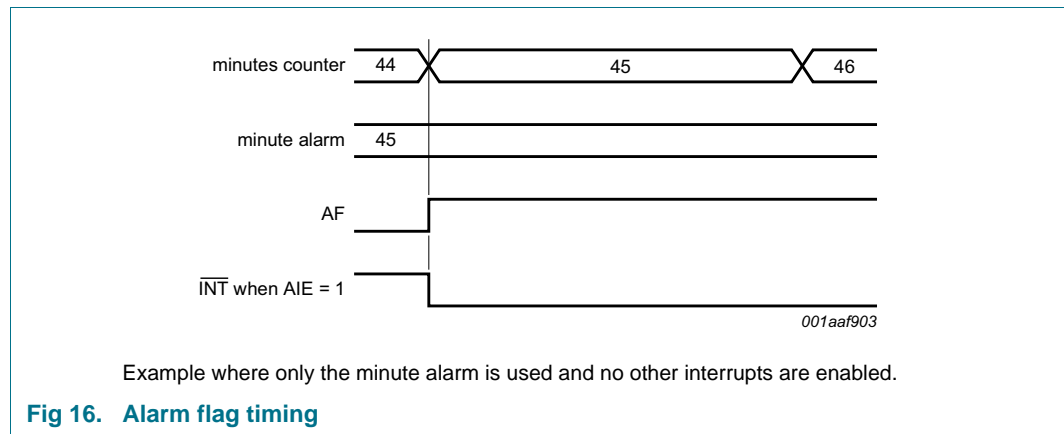

To prevent the timer flags being overwritten while clearing bit AF, logic AND is performed during a write access. A flag is cleared by writing logic 0 while a flag is not cleared by writing logic 1. Writing logic 1 results in the flag value remaining unchanged.

Table 26. Flag location in register Control_2

| Register | Bit | | | | | | | |
|-----------|------|------|------|----|----|---|---|---|
| | 7 | 6 | 5 | 4 | 3 | 2 | 1 | 0 |
| Control_2 | WTAF | CTAF | CTBF | SF | AF | - | - | - |

[Table 27](#) shows what instruction must be sent to clear bit AF. In this example, bit CTAF, CTBF, and bit SF are unaffected.

Table 27. Example to clear only AF (bit 3)

| Register | Bit ^[1] | | | | | | | |
|-----------|--------------------|---|---|---|---|---|---|---|
| | 7 | 6 | 5 | 4 | 3 | 2 | 1 | 0 |
| Control_2 | 0 | 1 | 1 | 1 | 0 | - | - | - |

[1] The bits labeled as - have to be rewritten with the previous values.

8.7.6 Alarm interrupts

Generation of interrupts from the alarm function is controlled via the bit AIE (register Control_1). If AIE is enabled, the $\overline{\text{INT1}}$ follows the status of bit AF (register Control_2). Clearing AF immediately clears $\overline{\text{INT1}}$. No pulse generation is possible for alarm interrupts.

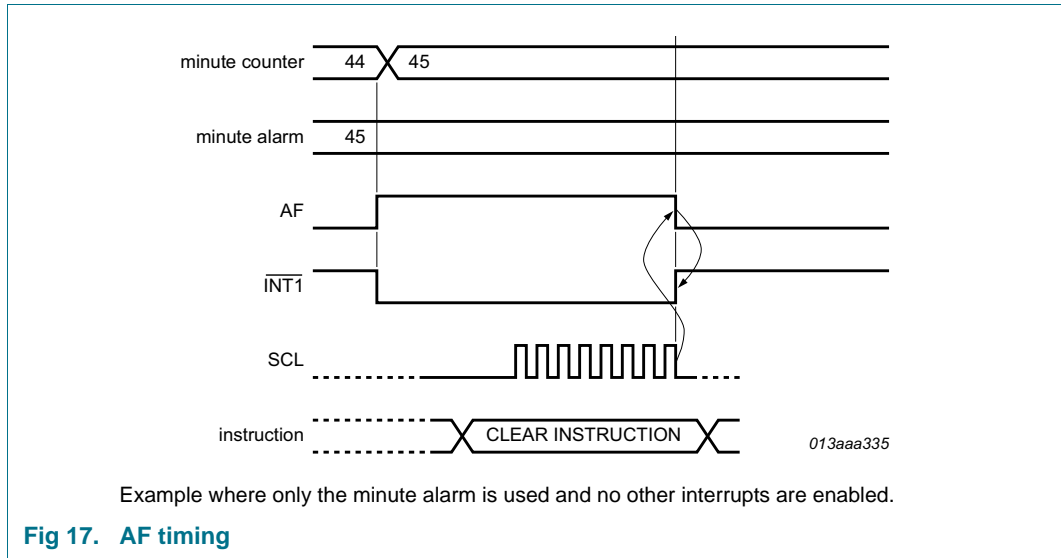

8.8 Register Offset

The PCF8523 incorporates an offset register (address 0Eh), which can be used to implement several functions, like:

- Aging adjustment
- Temperature compensation
- Accuracy tuning

Table 28. Offset - offset register (address 0Eh) bit description

| Bit | Symbol | Value | Description |
|--------|-------------|------------------------------|-------------------------------------|
| 7 | MODE | 0 ^[1] | offset is made once every two hours |
| | | 1 | offset is made once every minute |
| 6 to 0 | OFFSET[6:0] | see Table 29 | offset value |

[1] Default value.

For MODE = 0, each LSB introduces an offset of 4.34 ppm. For MODE = 1, each LSB introduces an offset of 4.069 ppm. The values of 4.34 ppm and 4.069 ppm are based on a nominal 32.768 kHz clock. The offset value is coded in two's complement giving a range of +63 LSB to -64 LSB.

Table 29. Offset values (in period time, not frequency)

| OFFSET[6:0] | Offset value in decimal | Offset value in ppm | |
|-------------|-------------------------|----------------------------|-------------------------|
| | | Every two hours (MODE = 0) | Every minute (MODE = 1) |
| 0111111 | +63 | +273.420 | +256.347 |
| 0111110 | +62 | +269.080 | +252.278 |
| : | : | : | : |
| 0000010 | +2 | +8.680 | +8.138 |
| 0000001 | +1 | +4.340 | +4.069 |
| 0000000 | 0 ^[1] | 0 ^[1] | 0 ^[1] |
| 1111111 | -1 | -4.340 | -4.069 |
| 1111110 | -2 | -8.680 | -8.138 |
| : | : | : | : |
| 1000001 | -63 | -273.420 | -256.347 |
| 1000000 | -64 | -277.760 | -260.416 |

[1] Default mode.

The correction is made by adding or subtracting clock correction pulses, thereby changing the period of a single second.

It is possible to monitor when correction pulses are applied. To enable correction interrupt generation, bit CIE (register Control_1) has to be set logic 1. At every correction cycle a $\frac{1}{4096}$ s pulse is generated on pin INTx. If multiple correction pulses are applied, a $\frac{1}{4096}$ s interrupt pulse is generated for each correction pulse applied.

8.8.1 Correction when MODE = 0

The correction is triggered once per two hours and then correction pulses are applied once per minute until the programmed correction values have been implemented.

Table 30. Correction pulses for MODE = 0

| Correction value | Update every n th hour | Minute | Correction pulses on INT1 per minute ^[1] |
|------------------|-----------------------------------|--------------------|-----------------------------------------------------|
| +1 or -1 | 2 | 00 | 1 |
| +2 or -2 | 2 | 00 and 01 | 1 |
| +3 or -3 | 2 | 00, 01, and 02 | 1 |
| : | : | : | : |
| +59 or -59 | 2 | 00 to 58 | 1 |
| +60 or -60 | 2 | 00 to 59 | 1 |
| +61 or -61 | 2 | 00 to 59 | 1 |
| | 2nd and next hour | 00 | 1 |
| +62 or -62 | 2 | 00 to 59 | 1 |
| | 2nd and next hour | 00 and 01 | 1 |
| +63 or -63 | 2 | 00 to 59 | 1 |
| | 2nd and next hour | 00, 01, and 02 | 1 |
| -64 | 2 | 00 to 59 | 1 |
| | 2nd and next hour | 00, 01, 02, and 03 | 1 |

[1] The correction pulses on pin $\overline{\text{INT1}}$ are $\frac{1}{64}$ s wide.

In MODE = 0, any timer or clock output using a frequency below 64 Hz is affected by the clock correction (see [Table 31](#)).

Table 31. Effect of clock correction for MODE = 0

| CLKOUT frequency (Hz) | Effect of correction | Timer source clock frequency (Hz) | Effect of correction |
|-----------------------|----------------------|-----------------------------------|----------------------|
| 32768 | no effect | 4096 | no effect |
| 16384 | no effect | 64 | no effect |
| 8192 | no effect | 1 | affected |
| 4096 | no effect | $\frac{1}{60}$ | affected |
| 1024 | no effect | $\frac{1}{3600}$ | affected |
| 32 | affected | - | - |
| 1 | affected | - | - |

8.8.2 Correction when MODE = 1

The correction is triggered once per minute and then correction pulses are applied once per second up to a maximum of 60 pulses. When correction values greater than 60 pulses are used, additional correction pulses are made in the 59th second.

Clock correction is made more frequently in MODE = 1; however, this can result in higher power consumption.

Table 32. Correction pulses for MODE = 1

| Correction value | Update every n th minute | Second | Correction pulses on INT1 per second ^[1] |
|------------------|-------------------------------------|----------------|-----------------------------------------------------|
| +1 or -1 | 2 | 00 | 1 |
| +2 or -2 | 2 | 00 and 01 | 1 |
| +3 or -3 | 2 | 00, 01, and 02 | 1 |
| : | : | : | : |
| +59 or -59 | 2 | 00 to 58 | 1 |
| +60 or -60 | 2 | 00 to 59 | 1 |
| +61 or -61 | 2 | 00 to 58 | 1 |
| | 2 | 59 | 2 |
| +62 or -62 | 2 | 00 to 58 | 1 |
| | 2 | 59 | 2 |
| +63 or -63 | 2 | 00 to 58 | 1 |
| | 2 | 59 | 4 |
| -64 | 2 | 00 to 58 | 1 |
| | 2 | 59 | 5 |

[1] The correction pulses on pin INTx are $\frac{1}{4096}$ s wide. For multiple pulses, they are repeated at an interval of $\frac{1}{2048}$ s.

In MODE = 1, clock outputs and timer source clocks affected by the clock correction are as shown in [Table 33](#).

Table 33. Effect of clock correction for MODE = 1

| CLKOUT frequency (Hz) | Effect of correction | Timer source clock frequency (Hz) | Effect of correction |
|-----------------------|----------------------|-----------------------------------|----------------------|
| 32768 | no effect | 4096 | no effect |
| 16384 | no effect | 64 | affected |
| 8192 | no effect | 1 | affected |
| 4096 | no effect | $\frac{1}{60}$ | affected |
| 1024 | no effect | $\frac{1}{3600}$ | affected |
| 32 | affected | - | - |
| 1 | affected | - | - |

8.8.3 Offset calibration workflow

The calibration offset has to be calculated based on the time. [Figure 18](#) shows the workflow how the offset register values can be calculated:

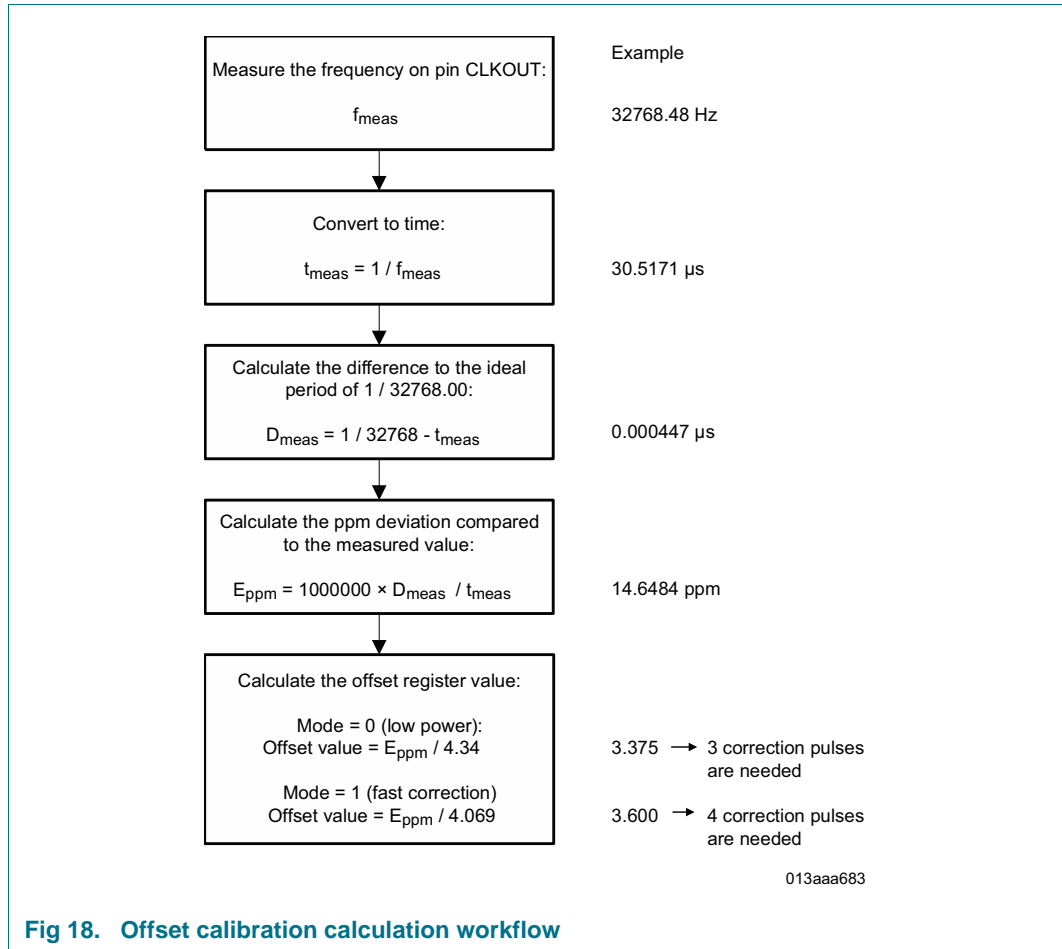

Fig 18. Offset calibration calculation workflow

8.9 Timer function

The PCF8523 has three timers:

- Timer A can be used as a watchdog timer or a countdown timer (see [Section 8.9.2](#)). It can be configured by using TAC[1:0] in the Tmr_CLKOUT_ctrl register (0Fh)
- Timer B can be used as a countdown timer (see [Section 8.9.3](#)). It can be configured by using TBC in the Tmr_CLKOUT_ctrl register (0Fh)
- Second interrupt timer is used to generate an interrupt once per second (see [Section 8.9.4](#))

Timer A and timer B both have five selectable source clocks allowing for countdown periods from less than 1 ms to 255 h. To control the timer functions and timer output, the registers 01h, 0Fh, 10h, 11h, 12h, and 13h are used.

8.9.1 Timer registers

8.9.1.1 Register Tmr_CLKOUT_ctrl and clock output

Table 34. Tmr_CLKOUT_ctrl - timer and CLKOUT control register (address 0Fh) bit description

| Bit | Symbol | Value | Description |
|--------|----------|------------------------------|---------------------------------------------------------------------------------------------------------------------------------------------------|
| 7 | TAM | 0 ^[1] | permanent active interrupt for timer A and for the second interrupt timer |
| | | 1 | pulsed interrupt for timer A and the second interrupt timer |
| 6 | TBM | 0 ^[1] | permanent active interrupt for timer B |
| | | 1 | pulsed interrupt for timer B |
| 5 to 3 | COF[2:0] | see Table 35 | CLKOUT frequency selection |
| 2 to 1 | TAC[1:0] | 00 ^[1] to 11 | timer A is disabled |
| | | 01 | timer A is configured as countdown timer if CTAIE (register Control_2) is set logic 1, the interrupt is activated when the countdown timed out |
| | | 10 | timer A is configured as watchdog timer if WTAIE (register Control_2) is set logic 1, the interrupt is activated when timed out |
| 0 | TBC | 0 ^[1] | timer B is disabled |
| | | 1 | timer B is enabled if CTBIE (register Control_2) is set logic 1, the interrupt is activated when the countdown timed out |

[1] Default value.

8.9.1.2 CLKOUT frequency selection

Clock output operation is controlled by the COF[2:0] in the Tmr_CLKOUT_ctrl register. Frequencies of 32.768 kHz (default) down to 1 Hz can be generated (see [Table 35](#)) for use as a system clock, microcontroller clock, input to a charge pump, or for calibration of the oscillator.

A programmable square wave is available at pin $\overline{\text{INT1}}/\text{CLKOUT}$ and pin CLKOUT, which are both open-drain outputs. Pin $\overline{\text{INT1}}/\text{CLKOUT}$ has both functions of INT1 and CLKOUT combined.

The duty cycle of the selected clock is not controlled but due to the nature of the clock generation, all clock frequencies except 32.768 kHz have a duty cycle of 50 : 50.

The STOP bit function can also affect the CLKOUT signal, depending on the selected frequency. When STOP is active, the $\overline{\text{INT1}}/\text{CLKOUT}$ and CLKOUT pins are high-impedance for all frequencies except of 32.768 kHz, 16.384 kHz and 8.192 kHz. For more details, see [Section 8.10](#).

Table 35. CLKOUT frequency selection

| COF[2:0] | CLKOUT frequency (Hz) | Typical duty cycle ^[1] | Effect of STOP bit |
|--------------------|--------------------------|-----------------------------------|--------------------|
| 000 ^[2] | 32768 | 60 : 40 to 40 : 60 | no effect |
| 001 | 16384 | 50 : 50 | no effect |
| 010 | 8192 | 50 : 50 | no effect |
| 011 | 4096 | 50 : 50 | CLKOUT = high-Z |
| 100 | 1024 | 50 : 50 | CLKOUT = high-Z |
| 101 | 32 | 50 : 50 ^[3] | CLKOUT = high-Z |
| 110 | 1 | 50 : 50 ^[3] | CLKOUT = high-Z |
| 111 | CLKOUT disabled (high-Z) | | |

[1] Duty cycle definition: % HIGH-level time : % LOW-level time.

[2] Default value.

[3] Clock frequencies may be affected by offset correction.

8.9.1.3 Register Tmr_A_freq_ctrl

Table 36. Tmr_A_freq_ctrl - timer A frequency control register (address 10h) bit description

| Bit | Symbol | Value | Description |
|--------|----------|--------------------|----------------------------------------------------------|
| 7 to 3 | - | - | unused |
| 2 to 0 | TAQ[2:0] | - | source clock for timer A (see Table 40) |
| | | 000 | 4.096 kHz |
| | | 001 | 64 Hz |
| | | 010 | 1 Hz |
| | | 011 | 1/60 Hz |
| | | 111 ^[1] | 1/3600 Hz |
| | | 110 100 | |

[1] Default value.

8.9.1.4 Register Tmr_A_reg

Table 37. Tmr_A_reg - timer A value register (address 11h) bit description

| Bit | Symbol | Value | Description |
|--------|----------|----------|----------------------------|
| 7 to 0 | T_A[7:0] | 00 to FF | timer value ^[1] |

[1] Timer period in seconds: $timerperiod = \frac{T_A}{SourceClockFrequency}$ where T_A is the countdown value.

8.9.1.5 Register Tmr_B_freq_ctrl

Table 38. Tmr_B_freq_ctrl - timer B frequency control register (address 12h) bit description

| Bit | Symbol | Value | Description |
|--------|----------|--------------------|----------------------------------------------------------|
| 7 | - | - | unused |
| 6 to 4 | TBW[2:0] | - | low pulse width for pulsed timer B interrupt |
| | | 000 ^[1] | 46.875 ms |
| | | 001 | 62.500 ms |
| | | 010 | 78.125 ms |
| | | 011 | 93.750 ms |
| | | 100 | 125.000 ms |
| | | 101 | 156.250 ms |
| | | 110 | 187.500 ms |
| | | 111 | 218.750 ms |
| 3 | - | - | unused |
| 2 to 0 | TBQ[2:0] | - | source clock for timer B (see Table 40) |
| | | 000 | 4.096 kHz |
| | | 001 | 64 Hz |
| | | 010 | 1 Hz |
| | | 011 | 1/60 Hz |
| | | 111 ^[1] | 1/3600 Hz |
| | | 110 100 | |

[1] Default value.

8.9.1.6 Register Tmr_B_reg

Table 39. Tmr_B_reg - timer B value register (address 13h) bit description

| Bit | Symbol | Value | Description |
|--------|----------|----------|----------------------------|
| 7 to 0 | T_B[7:0] | 00 to FF | timer value ^[1] |

[1] Timer period in seconds: $timerperiod = \frac{T_B}{SourceClockFrequency}$ where T_B is the countdown value.

8.9.1.7 Programmable timer characteristics

Table 40. Programmable timer characteristics

| TAQ[2:0] TBQ[2:0] | Timer source clock frequency | Units | Minimum timer-period (T_x = 1) | Units | Maximum timer-period (T_x = 255) | Units |
|----------------------|---------------------------------|-------|--------------------------------------|-------|----------------------------------------|-------|
| 000 | 4.096 | kHz | 244 | µs | 62.256 | ms |
| 001 | 64 | Hz | 15.625 | ms | 3.984 | s |
| 010 | 1 | Hz | 1 | s | 255 | s |
| 011 | 1/60 | Hz | 1 | min | 255 | min |
| 111 110 100 | 1/3600 | Hz | 1 | hour | 255 | hour |

8.9.2 Timer A

With the bit field TAC[1:0] in register Tmr_CLKOUT_ctrl (0Fh) Timer A can be configured as a countdown timer (TAC[1:0] = 01) or watchdog timer (TAC[1:0] = 10).

8.9.2.1 Watchdog timer function

The 3 bits TAQ[2:0] in register Tmr_A_freq_ctrl (10h) determine one of the five source clock frequencies for the watchdog timer: 4.096 kHz, 64 Hz, 1 Hz, $\frac{1}{60}$ Hz or $\frac{1}{3600}$ Hz (see [Table 36](#)).

The generation of interrupts from the watchdog timer is controlled by using WTAIE bit (register Control_2).

When configured as a watchdog timer (TAC[1:0] = 10), the 8-bit timer value in register Tmr_A_reg (11h) determines the watchdog timer-period.

The watchdog timer counts down from value T_A in register Tmr_A_reg (11h). When the counter reaches 1, the watchdog timer flag WTAF (register Control_2) is set logic 1 on the next rising edge of the timer clock (see [Figure 19](#)). In that case:

- If WTAIE = 1, an interrupt will be generated
- If WTAIE = 0, no interrupt will be generated

The interrupt generated by the watchdog timer function of timer A may be generated as pulsed signal or a permanently active signal. The TAM bit (register Tmr_CLKOUT_ctrl) is used to control the interrupt generation mode.

The counter does not automatically reload. When loading the counter with any valid value of T_A, except 0:

- The flag WTAF is reset (WTAF = 0)
- Interrupt is cleared
- The watchdog timer starts

When loading the counter with 0:

- The flag WTAF is reset (WTAF = 0)
- Interrupt is cleared
- The watchdog timer stops

WTAF is read only. A read of the register Control_2 (01h) automatically resets WTAF (WTAF = 0) and clears the interrupt.

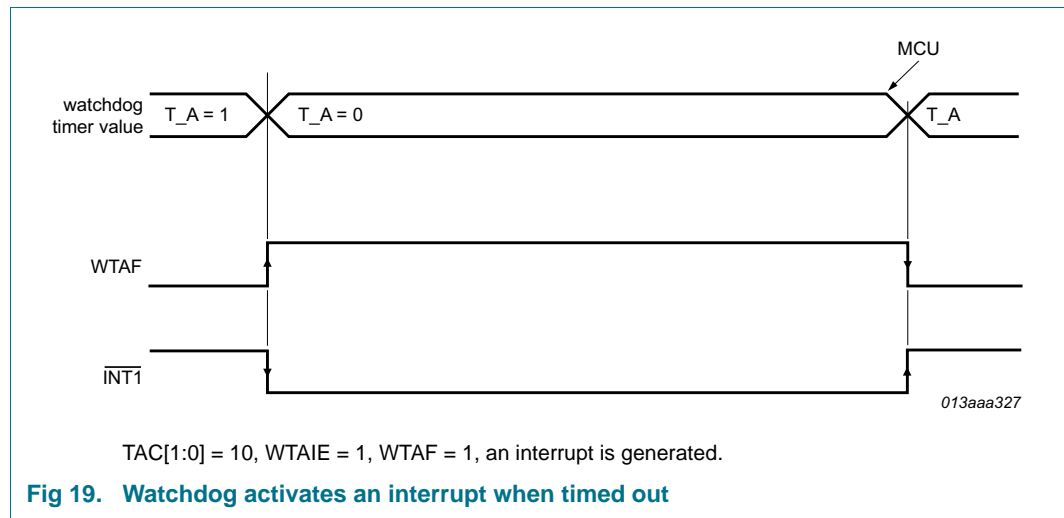

8.9.2.2 Countdown timer function

When configured as a countdown timer (TAC[1:0] = 01), timer A counts down from the software programmed 8-bit binary value T_A in register Tmr_A_reg (11h). When the counter reaches 1, the following events occur on the next rising edge of the timer clock (see [Figure 20](#)):

- The countdown timer flag CTAF (register Control_2) is set logic 1
- When the interrupt generation is enabled (CTAIE = 1), an interrupt signal on $\overline{\text{INT1}}$ is generated
- The counter automatically reloads
- The next timer-period starts

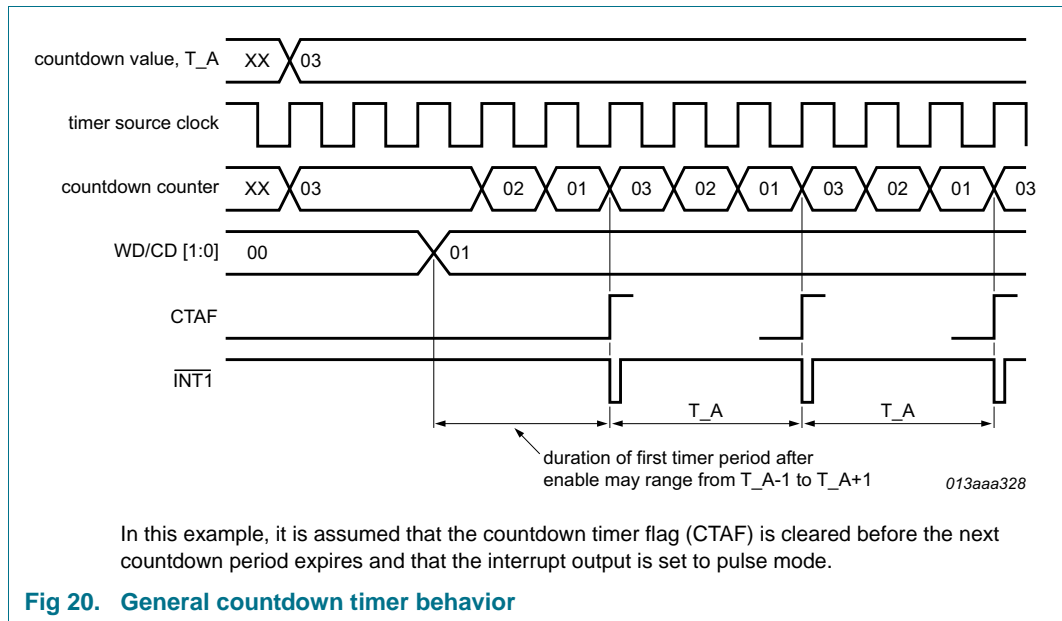

At the end of every countdown, the timer sets the countdown timer flag CTAF (register Control_2). CTAF may only be cleared by using the interface. Instructions, how to clear a flag, is given in [Section 8.7.5](#).

When reading the timer, the current countdown value is returned and **not** the initial value T_A. Since it is not possible to freeze the countdown timer counter during read back, it is recommended to read the register twice and check for consistent results.

If a new value of T_A is written before the end of the actual timer-period, this value takes immediate effect. It is not recommended to change T_A without first disabling the counter by setting TAC[1:0] = 00 (register Tmr_CLKOUT_ctrl). The update of T_A is asynchronous to the timer clock. Therefore changing it on the fly could result in a corrupted value loaded into the countdown counter. This can result in an undetermined countdown period for the first period. The countdown value T_A will be correctly stored and correctly loaded on subsequent timer-periods.

Loading the counter with 0 effectively stops the timer.

When starting the countdown timer for the first time, only the first period does not have a fixed duration. The amount of inaccuracy for the first timer-period depends on the chosen source clock, see [Table 41](#).

Table 41. First period delay for timer counter value T_A

| Timer source clock | Minimum timer-period | Maximum timer-period |
|-----------------------------|---------------------------------------|---------------------------------|
| 4.096 kHz | T_A | T_A + 1 |
| 64 Hz | T_A | T_A + 1 |
| 1 Hz | $(T_A - 1) + \frac{1}{64} \text{ Hz}$ | $T_A + \frac{1}{64} \text{ Hz}$ |
| $\frac{1}{60} \text{ Hz}$ | $(T_A - 1) + \frac{1}{64} \text{ Hz}$ | $T_A + \frac{1}{64} \text{ Hz}$ |
| $\frac{1}{3600} \text{ Hz}$ | $(T_A - 1) + \frac{1}{64} \text{ Hz}$ | $T_A + \frac{1}{64} \text{ Hz}$ |

The generation of interrupts from the countdown timer is controlled via the CTAIE bit (register Control_2).

When the interrupt generation is enabled (CTAIE = 1) and the countdown timer flag CTAF is set logic 1, an interrupt signal on $\overline{\text{INT1}}$ is generated. The interrupt may be generated as a pulsed signal every countdown period or as a permanently active signal, which follows the condition of CTAF (register Control_2). The TAM bit (register Tmr_CLKOUT_ctrl) is used to control this mode selection. The interrupt output may be disabled with the CTAIE bit (register Control_2).

8.9.3 Timer B

Timer B can only be used as a countdown timer and can be switched on and off by the TBC bit in register Tmr_CLKOUT_ctrl (0Fh).

The generation of interrupts from the countdown timer is controlled via the CTBIE bit (register Control_2).

When enabled, it counts down from the software programmed 8 bit binary value T_B in register Tmr_B_reg (13h). When the counter reaches 1 on the next rising edge of the timer clock, the following events occur (see Figure 21):

- The countdown timer flag CTBF (register Control_2) is set logic 1
- When the interrupt generation is enabled (CTBIE = 1), interrupt signals on $\overline{\text{INT1}}$ and $\overline{\text{INT2}}$ are generated
- The counter automatically reloads
- The next timer-period starts

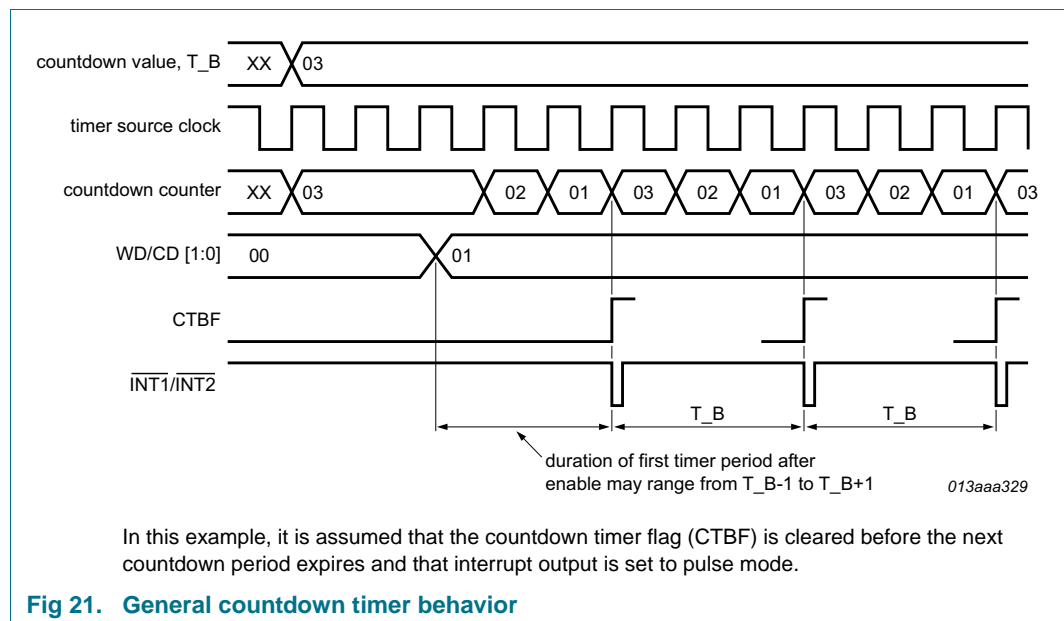

At the end of every countdown, the timer sets the countdown timer flag CTBF (register Control_2). CTBF may only be cleared by using the interface. Instructions, how to clear a flag, is given in Section 8.7.5.

When reading the timer, the current countdown value is returned and **not** the initial value T_B. Since it is not possible to freeze the countdown timer counter during read back, it is recommended to read the register twice and check for consistent results.

If a new value of T_B is written before the end of the actual timer-period, this value will take immediate effect. It is not recommended to change T_B without first disabling the counter by setting TBC logic 0 (register Tmr_CLKOUT_ctrl). The update of T_B is asynchronous to the timer clock. Therefore changing it on the fly could result in a corrupted value loaded into the countdown counter. This can result in an undetermined countdown period for the first period. The countdown value T_B will be correctly stored and correctly loaded on subsequent timer-periods.

Loading the counter with 0 effectively stops the timer.

When starting the countdown timer for the first time, only the first period does not have a fixed duration. The amount of inaccuracy for the first timer-period depends on the chosen source clock; see [Table 41](#).

When the interrupt generation is enabled (CTBIE = 1) and the countdown timer flag CTAF is set logic 1, interrupt signals on INT1 and INT2 are generated. The interrupt may be generated as a pulsed signal every countdown period or as a permanently active signal, which follows the condition of CTBF (register Control_2). The TBM bit (register Tmr_CLKOUT_ctrl) is used to control this mode selection. Interrupt output may be disabled with the CTBIE bit (register Control_2).

8.9.4 Second interrupt timer

PCF8523 has a pre-defined timer, which is used to generate an interrupt once per second. The pulse generator for the second interrupt timer operates from an internal 64 Hz clock and generates a pulse of $\frac{1}{64}$ s in duration. It is independent of the watchdog or countdown timer and can be switched on and off by the SIE bit in register Control_1 (00h).

The interrupt generated by the second interrupt timer may be generated as pulsed signal every second or as a permanently active signal. The TAM bit (register Tmr_CLKOUT_ctrl) is used to control the interrupt generation mode.

When the second interrupt timer is enabled (SIE = 1), then the timer sets the flag SF (register Control_2) every second (see [Table 42](#)). SF may only be cleared by using the interface. Instructions, how to clear a flag, are given in [Section 8.7.5](#).

Table 42. Effect of bit SIE on INT1 and bit SF

| SIE | Result on INT1 | Result on SF |
|-----|------------------------------|-----------------------------------------------|
| 0 | no interrupt generated | SF never set |
| 1 | an interrupt once per second | SF set when seconds counter increments |

When SF is logic 1:

- If TAM (register Tmr_CLKOUT_ctrl) is logic 1, the interrupt is generated as a pulsed signal every second
- If TAM is logic 0, the interrupt is a permanently active signal that remains, until SF is cleared

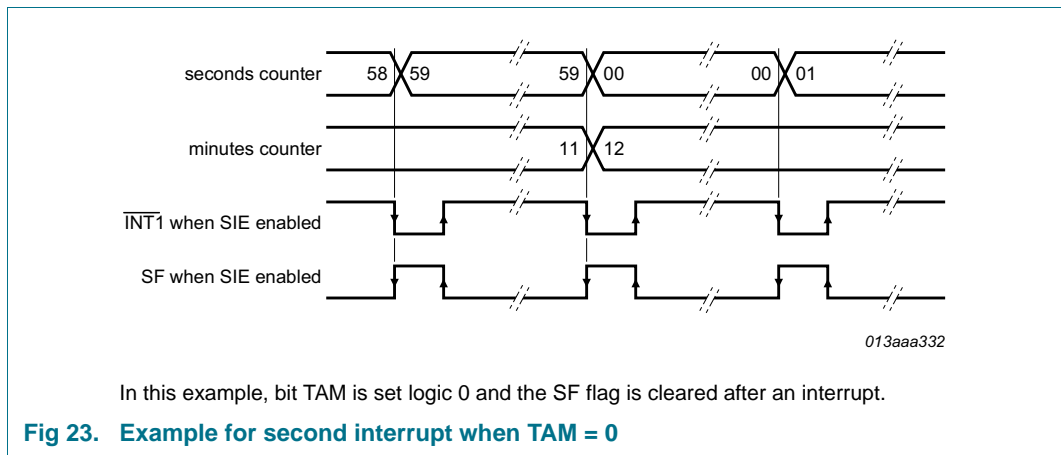
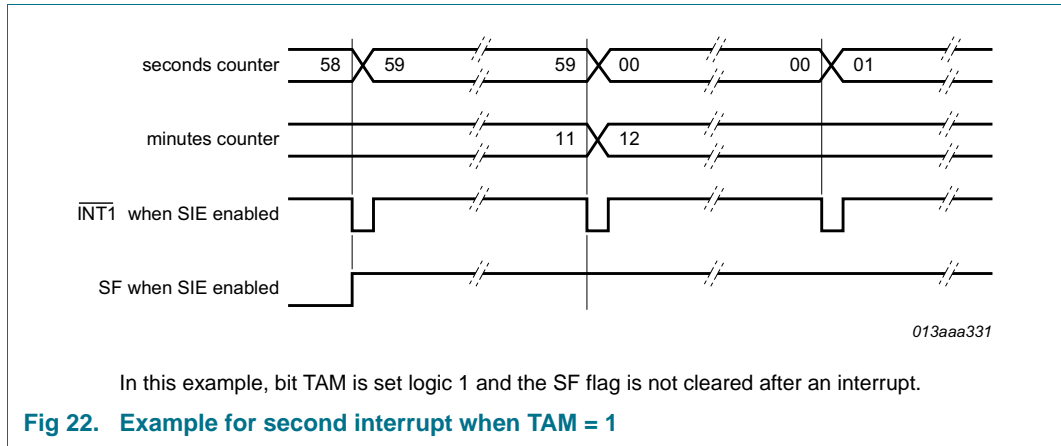

8.9.5 Timer interrupt pulse

The timer interrupt is generated as a pulsed signal when TAM or TBM are set logic 1. The pulse generator for the timer interrupt also uses an internal clock, but this time it is dependent on the selected source clock for the timer and on the timer register value T_x. So, the width of the interrupt pulse varies; see [Table 43](#) and [Table 44](#).

Table 43. Interrupt low pulse width for timer A

Pulse mode, bit TAM set logic 1.

| Source clock (Hz) | Interrupt pulse width | |
|-------------------|-----------------------------------|-----------------------------------|
| | T _A = 1 ^[1] | T _A > 1 ^[1] |
| 4096 | 122 μs | 244 μs |
| 64 | 7.812 ms | 15.625 ms |
| 1 | 15.625 ms | 15.625 ms |
| 1/60 | 15.625 ms | 15.625 ms |
| 1/3600 | 15.625 ms | 15.625 ms |

[1] T_A = loaded timer register value. Timer stops when T_A = 0.

For timer B, interrupt pulse width is programmable via bit TBM (register Tmr_CLKOUT_ctrl).

Table 44. Interrupt low pulse width for timer B

Pulse mode, bit TBM set logic 1.

| Source clock (Hz). | Interrupt pulse width | |
|--------------------|-----------------------------------|-----------------------------------|
| | T _B = 1 ^[1] | T _B > 1 ^[1] |
| 4096 | 122 μs | 244 μs |
| 64 | 7.812 ms | see Table 38 ^[2] |
| 1 | see Table 38 | : |
| 1/60 | : | : |
| 1/3600 | : | : |

[1] T_B = loaded timer register value. Timer stops when T_B = 0.

[2] If pulse period is shorter than the setting via bit TBW[2:0], the interrupt pulse width is set to 15.625 ms.

When flags like SF, CTAF, WTAF, and CTBF are cleared before the end of the interrupt pulse, then the interrupt pulse is shortened. This allows the source of a system interrupt to be cleared immediately when it is serviced, that is, the system does not have to wait for the completion of the pulse before continuing; see Figure 24 and Figure 25. Instructions for clearing flags can be found in Section 8.7.5. Instructions for clearing the bit WTAF can be found in Section 8.9.2.1.

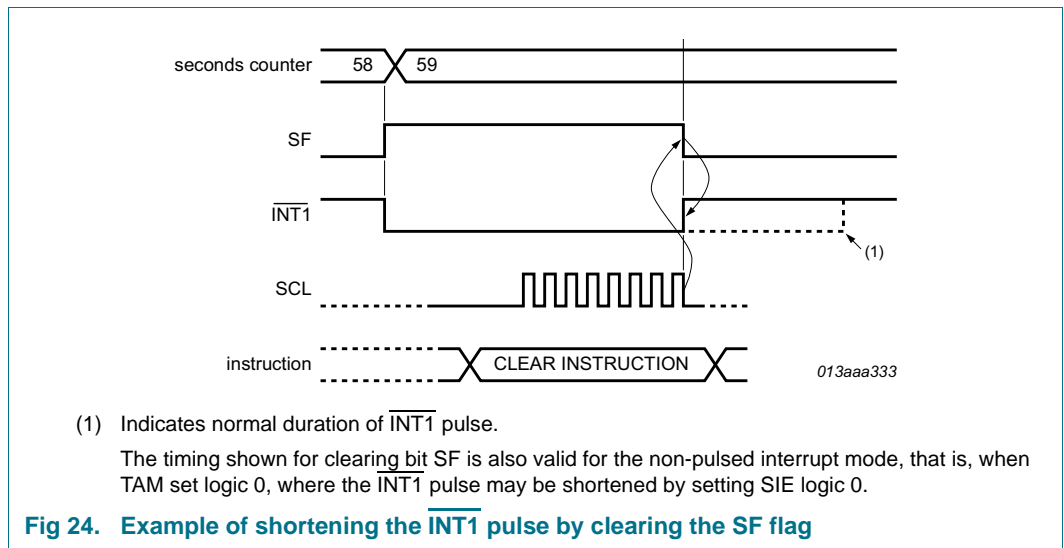

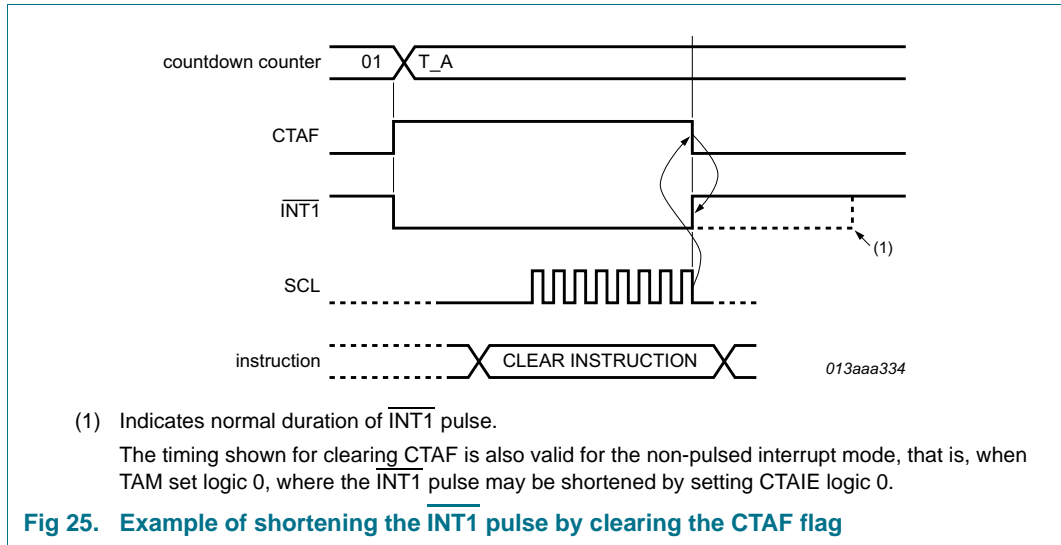

8.10 STOP bit function

The STOP bit function allows the accurate starting of the time circuits. The STOP bit function causes the upper part of the prescaler (F_2 to F_{14}) to be held in reset and thus no 1 Hz ticks are generated. The time circuits can then be set and do not increment until the STOP bit is released (see [Figure 26](#)).

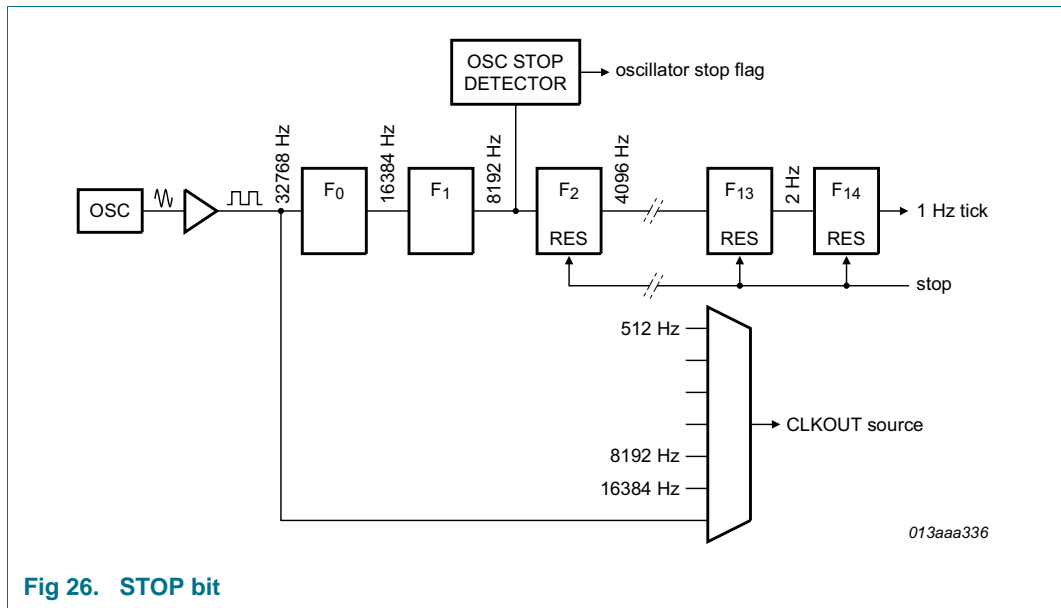

Fig 26. STOP bit

STOP does not affect the output of 32.768 kHz, 16.384 kHz or 8.192 kHz (see [Section 8.9.1.1](#)).

The lower two stages of the prescaler (F_0 and F_1) are not reset. And because the I²C-bus interface is asynchronous to the crystal oscillator, the accuracy of re-starting the time circuits will be between 0 and one 8.192 kHz cycle (see [Figure 27](#)).

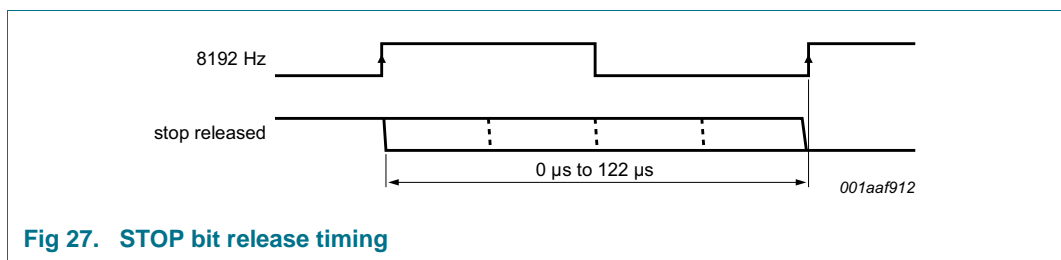

Fig 27. STOP bit release timing

The first increment of the time circuits is between 0.499878 s and 0.500000 s after STOP is released. The uncertainty is caused by the prescaler bits F_0 and F_1 not being reset (see [Table 45](#)).

Table 45. First increment of time circuits after STOP release

| Bit | Prescaler bits ^[1] | 1 Hz tick | Time | Comment |
|----------------------------------------------------------------------------------------------------------------------|------------------------------------------------------------------|-----------|----------|-------------------------------------------------------|
| STOP | F ₀ F ₁ -F ₂ to F ₁₄ | | hh:mm:ss | |
| Clock is running normally | | | | |
| 0 | 01-0000111010100 | | 12:45:12 | prescaler counting normally |
| STOP is activated by user; F₀F₁ are not reset and values cannot be predicted externally | | | | |
| 1 | XX-0000000000000 | | 12:45:12 | prescaler is reset; time circuits are frozen |
| New time is set by user | | | | |
| 1 | XX-0000000000000 | | 08:00:00 | prescaler is reset; time circuits are frozen |
| STOP is released by user | | | | |
| 0 | XX-0000000000000 | | 08:00:00 | prescaler is now running |
| 0 | XX-1000000000000 | | 08:00:00 | - |
| 0 | XX-0100000000000 | | 08:00:00 | - |
| 0 | XX-1100000000000 | | 08:00:00 | - |
| : | : | | : | : |
| 0 | 11-1111111111110 | | 08:00:00 | - |
| 0 | 00-0000000000001 | | 08:00:01 | 0 to 1 transition of F14 increments the time circuits |
| 0 | 10-0000000000001 | | 08:00:01 | - |
| : | : | | : | : |
| 0 | 11-1111111111111 | | 08:00:01 | - |
| 0 | 00-0000000000000 | | 08:00:01 | - |
| : | : | | : | : |
| 0 | 11-1111111111110 | | 08:00:01 | - |
| 0 | 00-0000000000001 | | 08:00:02 | 0 to 1 transition of F14 increments the time circuits |

[1] F₀ is clocked at 32.768 kHz.

8.11 I²C-bus interface

The I²C-bus is for bidirectional, two-line communication between different ICs or modules. The two lines are a Serial DATA line (SDA) and a Serial CLOCK line (SCL). Both lines are connected to a positive supply via a pull-up resistor. Data transfer is initiated only when the bus is not busy.

8.11.1 Bit transfer

One data bit is transferred during each clock pulse. The data on the SDA line remains stable during the HIGH period of the clock pulse as changes in the data line at this time are interpreted as control signals (see [Figure 28](#)).

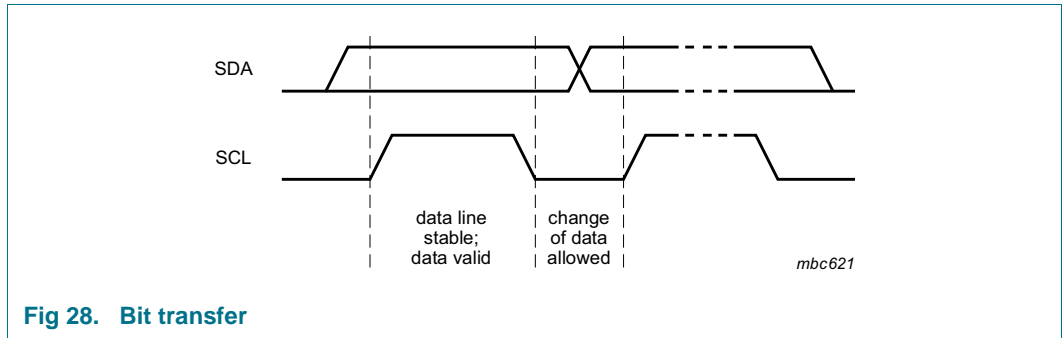

8.11.2 START and STOP conditions

Both data and clock lines remain HIGH when the bus is not busy. A HIGH-to-LOW transition of the data line, while the clock is HIGH, is defined as the START condition (S). A LOW-to-HIGH transition of the data line, while the clock is HIGH, is defined as the STOP condition (P) (see Figure 29).

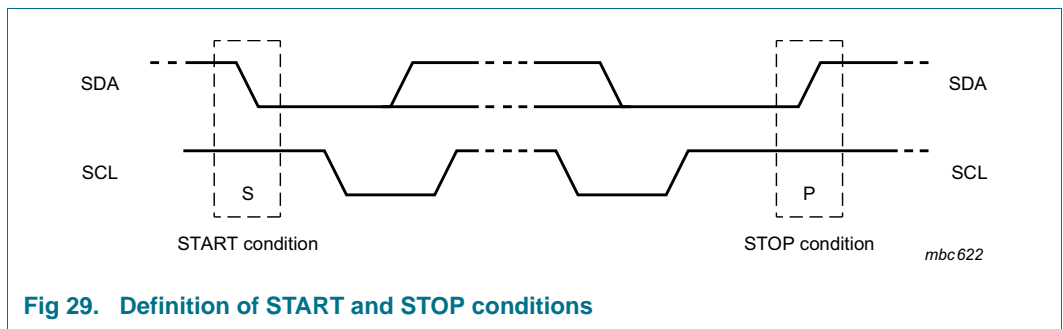

For this device, a repeated START is not allowed. Therefore, a STOP has to be released before the next START.

8.11.3 System configuration

A device generating a message is a transmitter; a device receiving a message is the receiver. The device that controls the message is the master and the devices, which are controlled by the master, are the slaves.

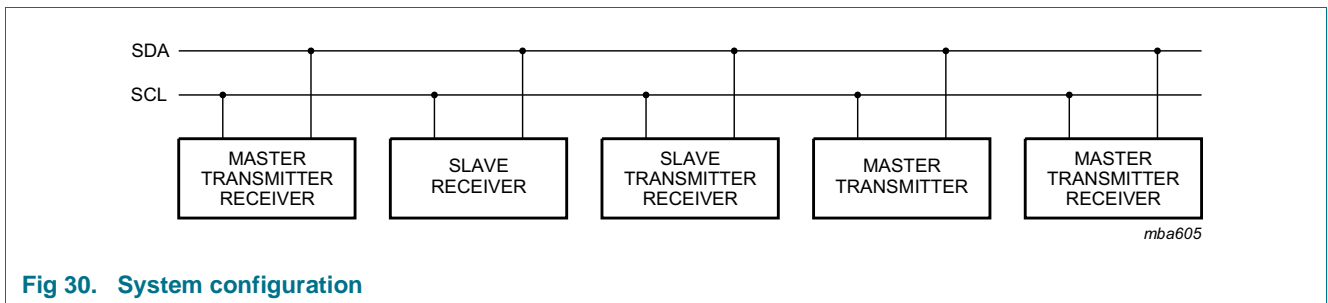

The PCF8523 can act as a slave transmitter and a slave receiver.

8.11.4 Acknowledge

The number of data bytes transferred between the START and STOP conditions from transmitter to receiver is unlimited. Each byte of 8 bits is followed by an acknowledge cycle.

- A slave receiver, which is addressed, must generate an acknowledge cycle after the reception of each byte
- Also a master receiver must generate an acknowledge cycle after the reception of each byte that has been clocked out of the slave transmitter
- The device that acknowledges must pull-down the SDA line during the acknowledge clock pulse, so that the SDA line is stable LOW during the HIGH period of the related acknowledge clock pulse (set-up and hold times must be considered)
- A master receiver must signal an end of data to the transmitter by not generating an acknowledge cycle on the last byte that has been clocked out of the slave. In this event, the transmitter must leave the data line HIGH to enable the master to generate a STOP condition

Acknowledgement on the I²C-bus is shown in [Figure 31](#).

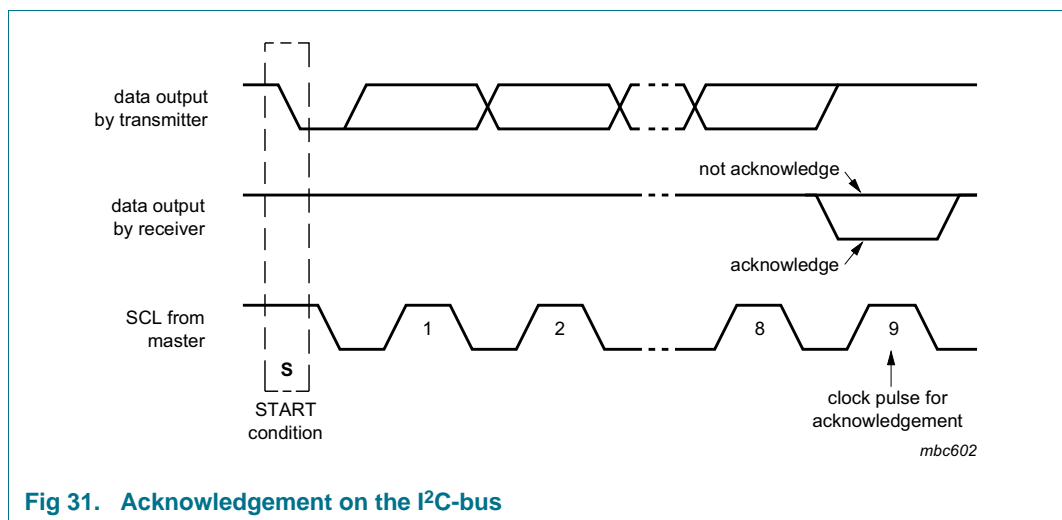

Fig 31. Acknowledgement on the I²C-bus

8.11.5 I²C-bus protocol

One I²C-bus slave address (1101 000) is reserved for the PCF8523. The entire I²C-bus slave address byte is shown in [Table 46](#).

Table 46. I²C slave address byte

| Bit | Slave address ^[1] | | | | | | | 0 |
|-----|------------------------------|---|---|---|---|---|---|-----|
| | 7 | 6 | 5 | 4 | 3 | 2 | 1 | |
| | MSB | | | | | | | LSB |
| | 1 | 1 | 0 | 1 | 0 | 0 | 0 | R/W |

[1] Devices with other I²C-bus slave addresses can be produced on request.

After a START condition, the I²C slave address has to be sent to the PCF8523 device.

The $\overline{R/\overline{W}}$ bit defines the direction of the following single or multiple byte data transfer. For the format and the timing of the START condition (S), the STOP condition (P) and the acknowledge bit (A) refer to the I²C-bus characteristics (see [Ref. 15 on page 71](#)). In the write mode, a data transfer is terminated by sending either the STOP condition or the START condition of the next data transfer.

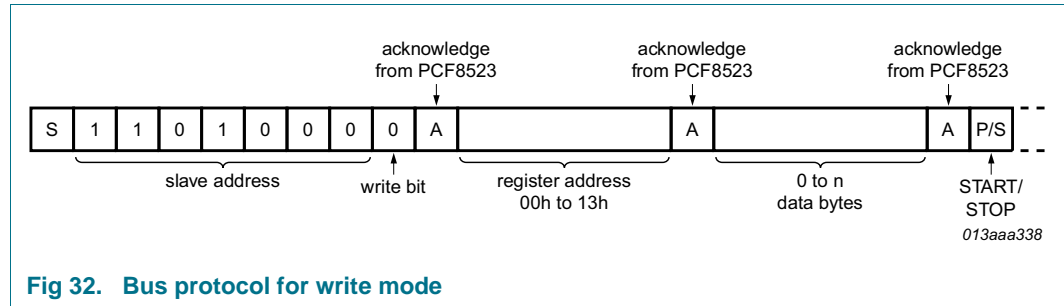

Fig 32. Bus protocol for write mode

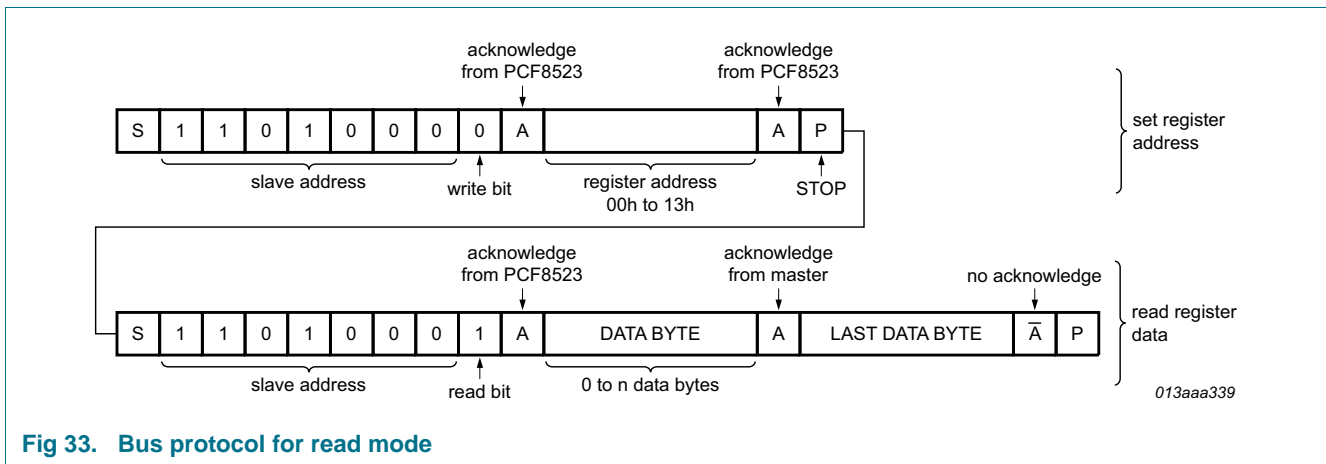

Fig 33. Bus protocol for read mode

9. Internal circuitry

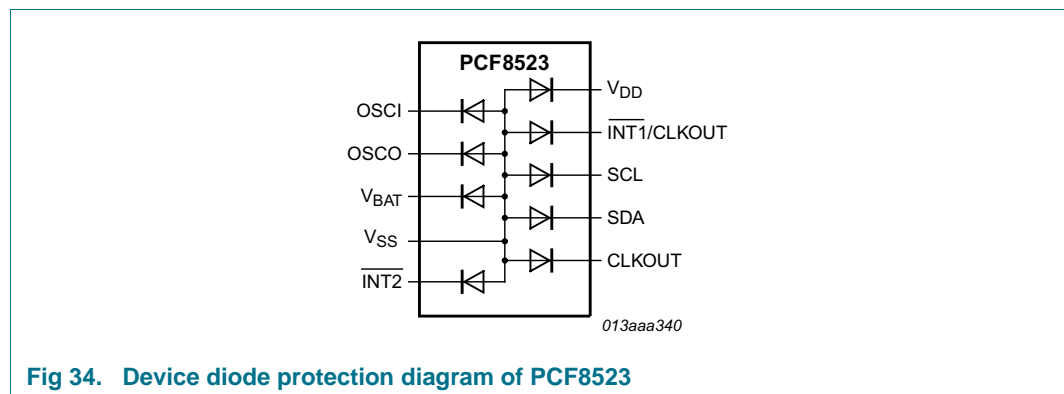

Fig 34. Device diode protection diagram of PCF8523

10. Safety notes

CAUTION



This device is sensitive to ElectroStatic Discharge (ESD). Observe precautions for handling electrostatic sensitive devices.

Such precautions are described in the *ANSI/ESD S20.20*, *IEC/ST 61340-5*, *JESD625-A* or equivalent standards.

CAUTION



Semiconductors are light sensitive. Exposure to light sources can cause the IC to malfunction. The IC must be protected against light. The protection must be applied to all sides of the IC.

11. Limiting values

Table 47. Limiting values

In accordance with the Absolute Maximum Rating System (IEC 60134).

| Symbol | Parameter | Conditions | Min | Max | Unit |
|------------------|---------------------------------|--------------------------------------------------|------|-------|------|
| V _{DD} | supply voltage | | -0.5 | +6.5 | V |
| I _{DD} | supply current | | -50 | +50 | mA |
| V _I | input voltage | | -0.5 | +6.5 | V |
| V _O | output voltage | | -0.5 | +6.5 | V |
| I _I | input current | | -10 | +10 | mA |
| I _O | output current | | -10 | +10 | mA |
| V _{BAT} | battery supply voltage | | -0.5 | +6.5 | V |
| P _{tot} | total power dissipation | | - | 300 | mW |
| V _{ESD} | electrostatic discharge voltage | HBM for all PCF8523 [1] | - | ±2000 | V |
| | | CDM for all packaged PCF8523 [2] | - | ±1500 | V |
| I _{lu} | latch-up current | [3] | - | 100 | mA |
| T _{stg} | storage temperature | [4] | -65 | +150 | °C |
| T _{amb} | ambient temperature | operating device | -40 | +85 | °C |

[1] Pass level; Human Body Model (HBM), according to [Ref. 8 "JESD22-A114"](#).

[2] Pass level; Charged-Device Model (CDM), according to [Ref. 9 "JESD22-C101"](#).

[3] Pass level; latch-up testing according to [Ref. 10 "JESD78"](#) at maximum ambient temperature (T_{amb(max)}).

[4] According to the store and transport requirements (see [Ref. 17 "UM10569"](#)) the devices have to be stored at a temperature of +8 °C to +45 °C and a humidity of 25 % to 75 %.

12. Static characteristics

Table 48. Static characteristics

$V_{DD} = 1.2\text{ V to }5.5\text{ V}$; $V_{SS} = 0\text{ V}$; $T_{amb} = -40\text{ °C to }+85\text{ °C}$; $f_{osc} = 32.768\text{ kHz}$; quartz $R_s = 40\text{ k}\Omega$; $C_L = 7\text{ pF}$; unless otherwise specified.

| Symbol | Parameter | Conditions | Min | Typ | Max | Unit | |
|------------------------------------------------------------------------------------------------------|----------------------------------|-----------------------------------------------------------------------------------------|-------------|------|----------------|---------------|---------------|
| Supplies | | | | | | | |
| V_{DD} | supply voltage | I ² C-bus inactive; for clock data integrity | | | | | |
| | | $T_{amb} = -40\text{ °C to }+85\text{ °C}$ | [1] | 1.2 | - | 5.5 | V |
| | | $T_{amb} = +10\text{ °C to }+85\text{ °C}$ | [2] | 1.0 | - | 5.5 | V |
| | | I ² C-bus active | | 1.6 | - | 5.5 | V |
| | power management function active | | 1.8 | - | 5.5 | V | |
| SR_f | falling slew rate | of V_{DD} | [3] | - | 0.7 | V/ms | |
| V_{BAT} | battery supply voltage | power management function active | 1.8 | - | 5.5 | V | |
| I_{DD} | supply current | I ² C-bus active; $f_{SCL} = 1000\text{ kHz}$ | | - | - | 200 | μA |
| | | I ² C-bus inactive ($f_{SCL} = 0\text{ Hz}$); interrupts disabled | | | | | |
| | | clock-out disabled; power management function disabled (PM[2:0] = 111) | | | | | |
| | | $T_{amb} = 25\text{ °C}$; $V_{DD} = 3.0\text{ V}$ | [4] | - | 150 | - | nA |
| | | $T_{amb} = -40\text{ °C to }+85\text{ °C}$; $V_{DD} = 2.0\text{ V to }5.0\text{ V}$ | [4] | - | - | 500 | nA |
| | | clock-out enabled at 32 kHz; power management function enabled (PM[2:0] = 000) | | | | | |
| | | $T_{amb} = 25\text{ °C}$; V_{BAT} or $V_{DD} = 3.0\text{ V}$ | [5] | - | 1200 | - | nA |
| $T_{amb} = -40\text{ °C to }+85\text{ °C}$; V_{BAT} or $V_{DD} = 2.0\text{ V to }5.0\text{ V}$ | [5] | - | - | 3600 | nA | | |
| $I_{L(bat)}$ | battery leakage current | V_{DD} active; $V_{BAT} = 3.0\text{ V}$ | - | 50 | 100 | nA | |
| Power management | | | | | | | |
| $V_{th(sw)bat}$ | battery switch threshold voltage | | 2.1 | 2.5 | 2.7 | V | |
| Inputs [6] | | | | | | | |
| V_{IL} | LOW-level input voltage | | - | - | $0.3V_{DD}$ | V | |
| V_{IH} | HIGH-level input voltage | | $0.7V_{DD}$ | - | - | V | |
| V_I | input voltage | | -0.5 | - | $V_{DD} + 0.5$ | V | |
| I_{LI} | input leakage current | $V_I = V_{SS}$ or V_{DD} | - | 0 | - | nA | |
| | | post ESD event | -1 | - | +1 | μA | |
| C_I | input capacitance | | [7] | - | 7 | pF | |

Table 48. Static characteristics ...continued

$V_{DD} = 1.2\text{ V to }5.5\text{ V}$; $V_{SS} = 0\text{ V}$; $T_{amb} = -40\text{ }^{\circ}\text{C to }+85\text{ }^{\circ}\text{C}$; $f_{osc} = 32.768\text{ kHz}$; quartz $R_s = 40\text{ k}\Omega$; $C_L = 7\text{ pF}$; unless otherwise specified.

| Symbol | Parameter | Conditions | Min | Typ | Max | Unit |
|----------------|-----------------------------|------------------------------------------------------------------------------------------------------------------------------------------------------------------------|----------|------|-----|------------------|
| Outputs | | | | | | |
| V_O | output voltage | on pins $\overline{\text{INT1}}/\text{CLKOUT}$, CLKOUT , $\overline{\text{INT2}}$, SDA (refers to external pull-up voltage) | -0.5 | - | 5.5 | V |
| V_{OL} | LOW-level output voltage | | V_{SS} | - | 0.4 | V |
| I_{OL} | LOW-level output current | output sink current; on pins $\overline{\text{INT1}}/\text{CLKOUT}$, CLKOUT , $\overline{\text{INT2}}$; $V_{OL} = 0.4\text{ V}$; $V_{DD} = 5\text{ V}$ [8] | 1.5 | - | - | mA |
| | | on pin SDA $V_{OL} = 0.4\text{ V}$; $V_{DD} = 3.0\text{ V}$ [8] | 20 | - | - | mA |
| I_{LO} | output leakage current | $V_O = V_{SS}$ or V_{DD} | - | 0 | - | nA |
| | | post ESD event | -1 | - | +1 | μA |
| $C_{L(itg)}$ | integrated load capacitance | on pins OSC0, OSC1 [9][10] | | | | |
| | | $C_L = 7\text{ pF}$ | 3.3 | 7 | 14 | pF |
| | | $C_L = 12.5\text{ pF}$ | 6 | 12.5 | 25 | pF |
| R_S | series resistance | [11] | - | - | 100 | $\text{k}\Omega$ |

- [1] For reliable oscillator start at power-up: $V_{DD} = V_{DD(min)} + 0.3\text{ V}$.
- [2] For reliable oscillator start at power-up: $V_{DD} = V_{DD(min)} + 0.5\text{ V}$.
- [3] Switching the supply from V_{DD} to V_{BAT} must be made slower than the specified slew rate.
- [4] Timer source clock = $1/3600\text{ Hz}$, level of pins SCL and SDA is V_{DD} or V_{SS} .
- [5] When the device is supplied via the V_{BAT} pin instead of the V_{DD} pin, the current values for I_{BAT} will be as specified for I_{DD} under the same conditions.
- [6] The I²C-bus is 5 V tolerant.
- [7] Implicit by design.
- [8] Tested on sample basis.
- [9] Integrated load capacitance, $C_{L(itg)}$, is a calculation of C_{OSCI} and C_{OSCO} in series: $C_{L(itg)} = \frac{(C_{OSCI} \cdot C_{OSCO})}{(C_{OSCI} + C_{OSCO})}$.
- [10] Tested at 25 °C.
- [11] Crystal characteristic specification.

13. Dynamic characteristics

Table 49. I²C-bus interface timing

All timing characteristics are valid within the operating supply voltage and ambient temperature range and reference to 30 % and 70 % with an input voltage swing of V_{SS} to V_{DD} (see [Figure 35](#)).

| Symbol | Parameter | Conditions | Standard mode | | Fast mode (FM) | | Fast mode plus (Fm+) ^[1] | | Unit |
|-------------------------|-------------------------------------------------------------------|------------|---------------|------|------------------------|-----|-------------------------------------|------|------|
| | | | Min | Max | Min | Max | Min | Max | |
| Pin SCL | | | | | | | | | |
| f _{SCL} | SCL clock frequency | [2] | - | 100 | - | 400 | - | 1000 | kHz |
| t _{LOW} | LOW period of the SCL clock | - | 4.7 | - | 1.3 | - | 0.5 | - | μs |
| t _{HIGH} | HIGH period of the SCL clock | - | 4.0 | - | 0.6 | - | 0.26 | - | μs |
| Pin SDA | | | | | | | | | |
| t _{SU;DAT} | data set-up time | - | 250 | - | 100 | - | 50 | - | ns |
| t _{HD;DAT} | data hold time | - | 0 | - | 0 | - | 0 | - | ns |
| Pins SCL and SDA | | | | | | | | | |
| t _{BUF} | bus free time between a STOP and START condition | - | 4.7 | - | 1.3 | - | 0.5 | - | μs |
| t _{SU;STO} | set-up time for STOP condition | - | 4.0 | - | 0.6 | - | 0.26 | - | μs |
| t _{HD;STA} | hold time (repeated) START condition | - | 4.0 | - | 0.6 | - | 0.26 | - | μs |
| t _{SU;STA} | set-up time for a repeated START condition | - | 4.7 | - | 0.6 | - | 0.26 | - | μs |
| t _r | rise time of both SDA and SCL signals | [3][4] | - | 1000 | 20 + 0.1C _b | 300 | - | 120 | ns |
| t _f | fall time of both SDA and SCL signals | [3][4] | - | 300 | 20 + 0.1C _b | 300 | - | 120 | ns |
| C _b | capacitive load for each bus line | - | - | 400 | - | 400 | - | 550 | pF |
| t _{VD;ACK} | data valid acknowledge time | [5] | - | 3.45 | - | 0.9 | - | 0.45 | μs |
| t _{VD;DAT} | data valid time | [6] | - | 3.45 | - | 0.9 | - | 0.45 | μs |
| t _{SP} | pulse width of spikes that must be suppressed by the input filter | [7] | - | 50 | - | 50 | - | 50 | ns |

[1] Fast mode plus guaranteed at 3.0 V < V_{DD} < 5.5 V.

[2] The minimum SCL clock frequency is limited by the bus time-out feature, which resets the serial bus interface if either the SDA or SCL is held LOW for a minimum of 25 ms. The bus time-out feature must be disabled for DC operation.

[3] A master device must internally provide a hold time of at least 300 ns for the SDA signal (refer to the V_{IL} of the SCL signal) in order to bridge the undefined region of the falling edge of SCL.

[4] The maximum t_r for the SDA and SCL bus lines is 300 ns. The maximum fall time for the SDA output stage, t_f is 250 ns. This allows series protection resistors to be connected between the SDA pin, the SCL pin and the SDA/SCL bus lines without exceeding the maximum t_r.

[5] t_{VD;ACK} = time for acknowledgement signal from SCL LOW to SDA output LOW.

[6] t_{VD;DAT} = minimum time for valid SDA output following SCL LOW.

[7] Input filters on the SDA and SCL inputs suppress noise spikes of less than 50 ns.

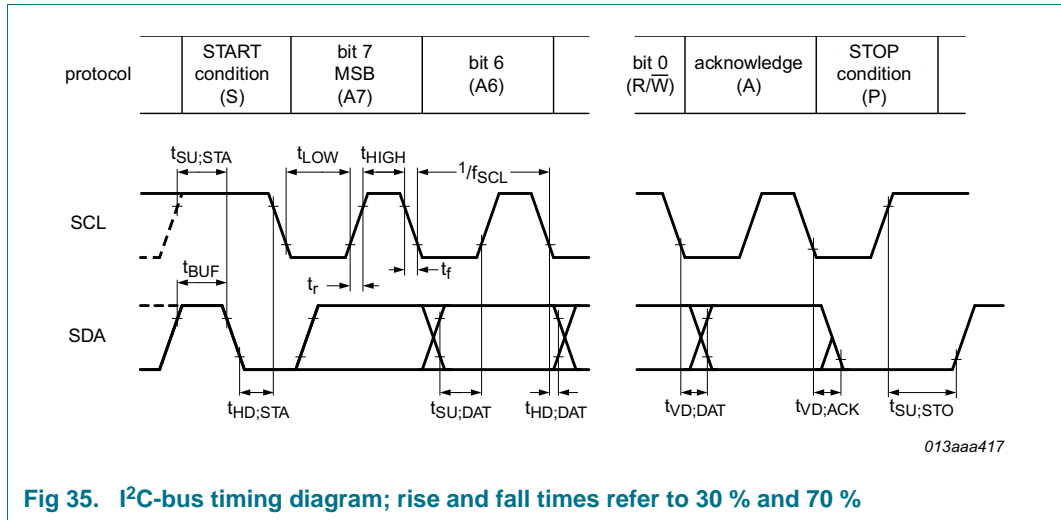

Fig 35. I²C-bus timing diagram; rise and fall times refer to 30 % and 70 %

14. Application information

14.1 Battery switch-over applications

The functionality of the battery switch-over is limited by the fact that the power supply V_{DD} is monitored every 1 ms in order to save power consumption. Considering further that the battery switch-over threshold value ($V_{th(sw)bat}$) is typically 2.5 V, the power management operating limit ($V_{DD(min)}$) is 1.8 V, and that V_{DD} is monitored every 1 ms, the battery switch-over works properly in all cases where V_{DD} falls with a rate lower than 0.7 V/ms, as shown in Figure 36:

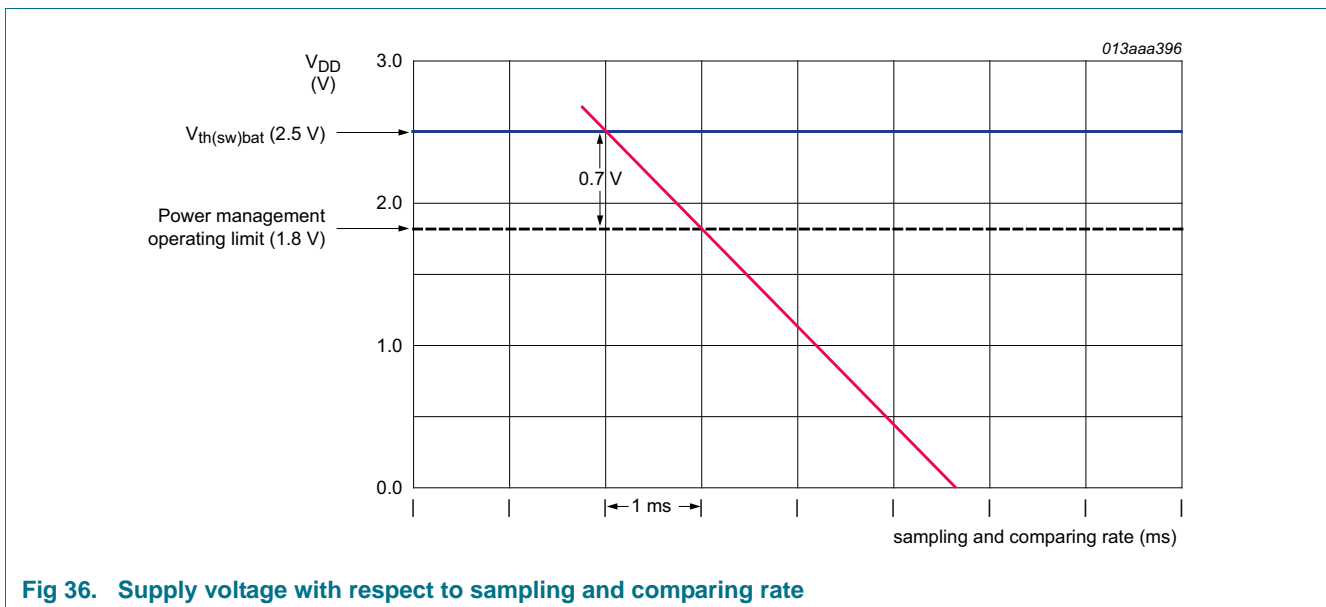

Fig 36. Supply voltage with respect to sampling and comparing rate

In an application, where during power-down, the current consumption on pin V_{DD} is

- in the range of a few μA a capacitor of 100 nF on pin V_{DD} is enough to allow a slow power-down and the proper functionality of the battery switch-over³

- in the range of a few hundreds of μA , the value of the capacitor on pin V_{DD} must be increased to force a falling gradient of less than 0.7 V/ms on pin V_{DD} to assure the proper functionality of the battery switch-over⁴
- higher than some mA it is recommended to add an RC network on the V_{DD} pin, as shown in [Figure 37](#):⁵

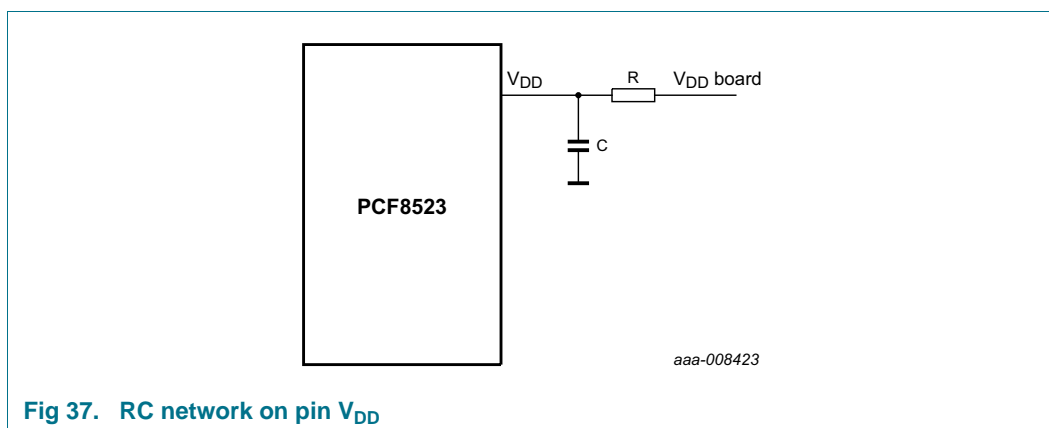

Fig 37. RC network on pin V_{DD}

A series resistor of $1 \text{ k}\Omega$ and a capacitor of $3.3 \mu\text{F}$ assure the proper functionality of the battery switch-over even with very fast V_{DD} slope.

Note that:

- it is not suggested to assemble a series resistor higher than $2.2 \text{ k}\Omega$ because of the associated voltage drop
- lower values of capacitors are possible, depending on the V_{DD} slope in the application.

3. Like in the case of no interface activity and/or early power fail detection functions that allow the microcontroller to perform early backup operations and to set power-down modes.
4. Like in the case of interface activity.
5. Like in the case where an additional circuitry is supplied from V_{DD} .

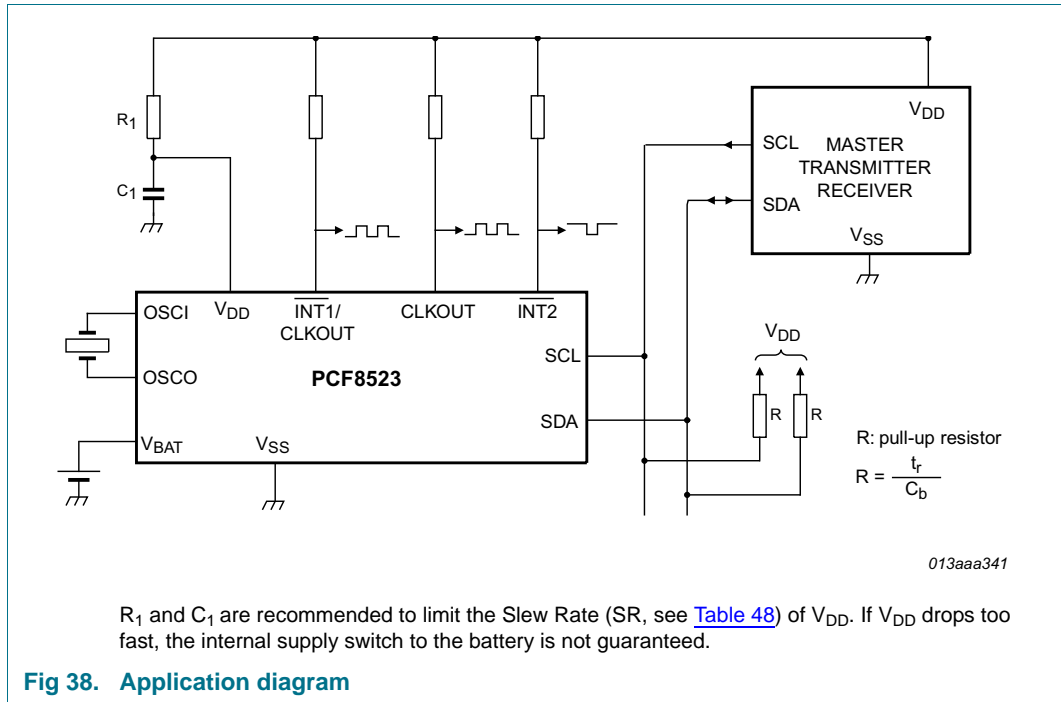

R₁ and C₁ are recommended to limit the Slew Rate (SR, see [Table 48](#)) of V_{DD}. If V_{DD} drops too fast, the internal supply switch to the battery is not guaranteed.

15. Package outline

SO8: plastic small outline package; 8 leads; body width 3.9 mm

SOT96-1

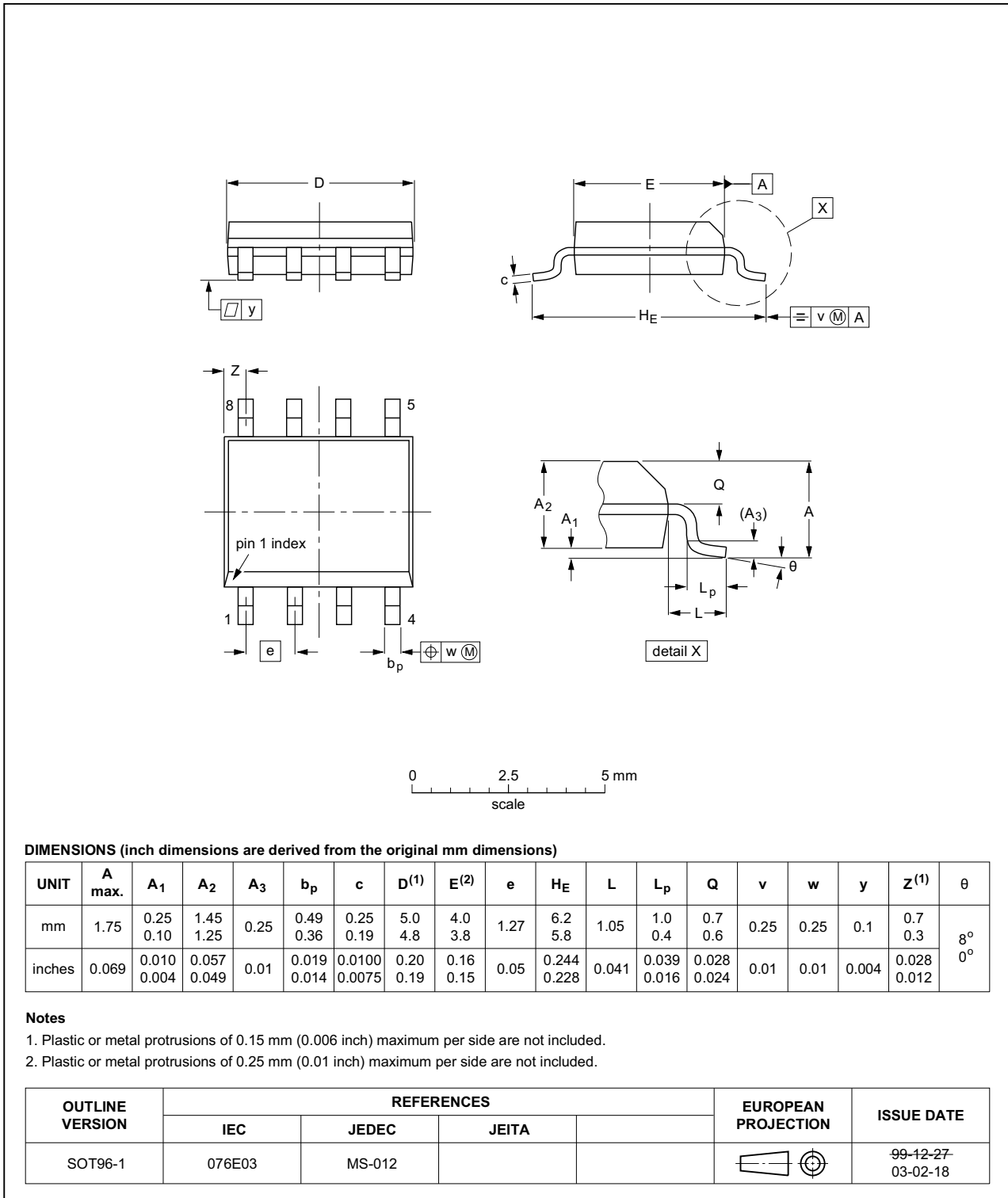

Fig 39. Package outline SOT96-1 (SO8) of PCF8523T

HVSON8: plastic thermal enhanced very thin small outline package; no leads;
8 terminals; body 4 x 4 x 0.85 mm

SOT909-1

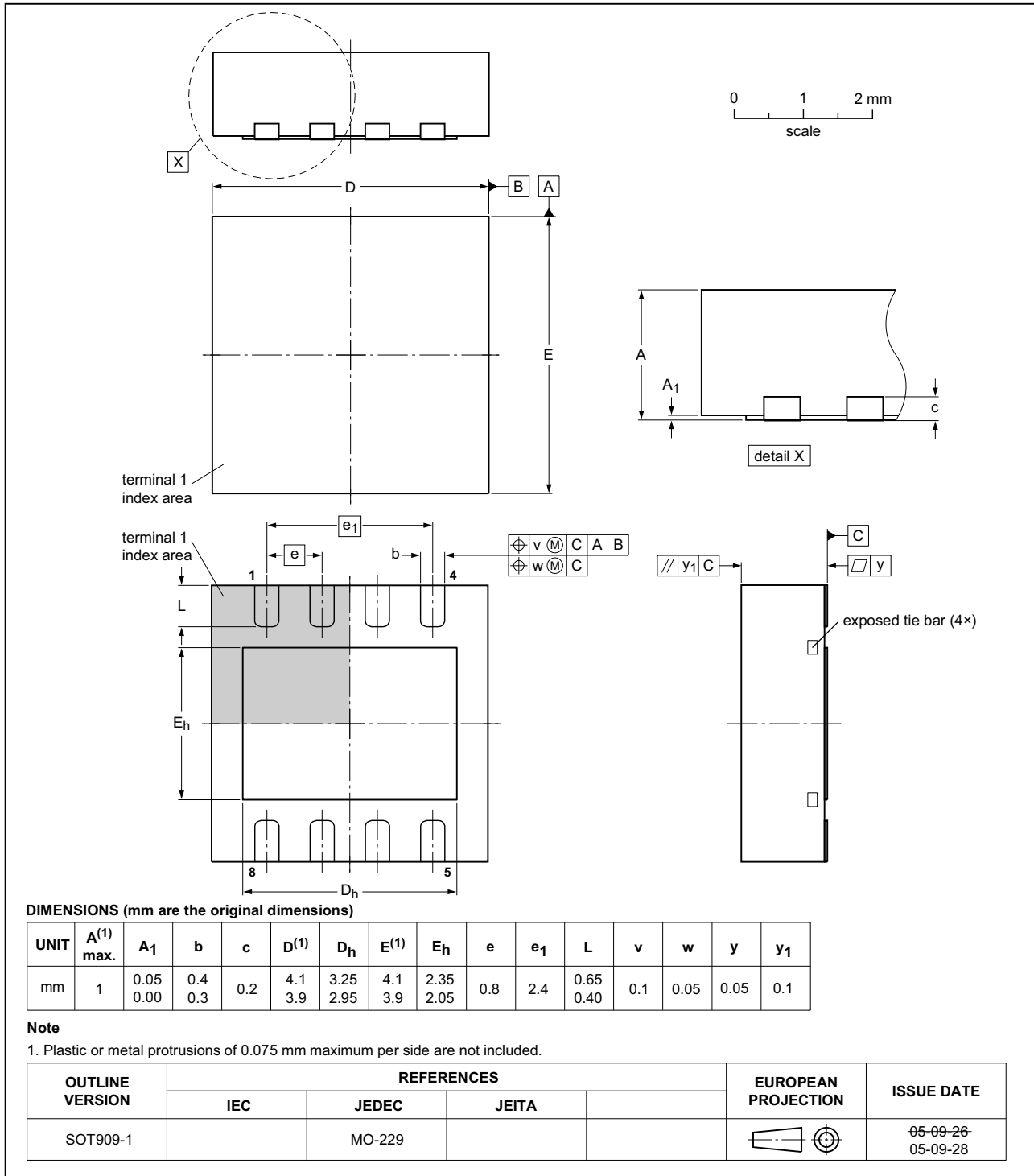

Fig 40. Package outline SOT909-1 (HVSON8) of PCF8523TK

TSSOP14: plastic thin shrink small outline package; 14 leads; body width 4.4 mm

SOT402-1

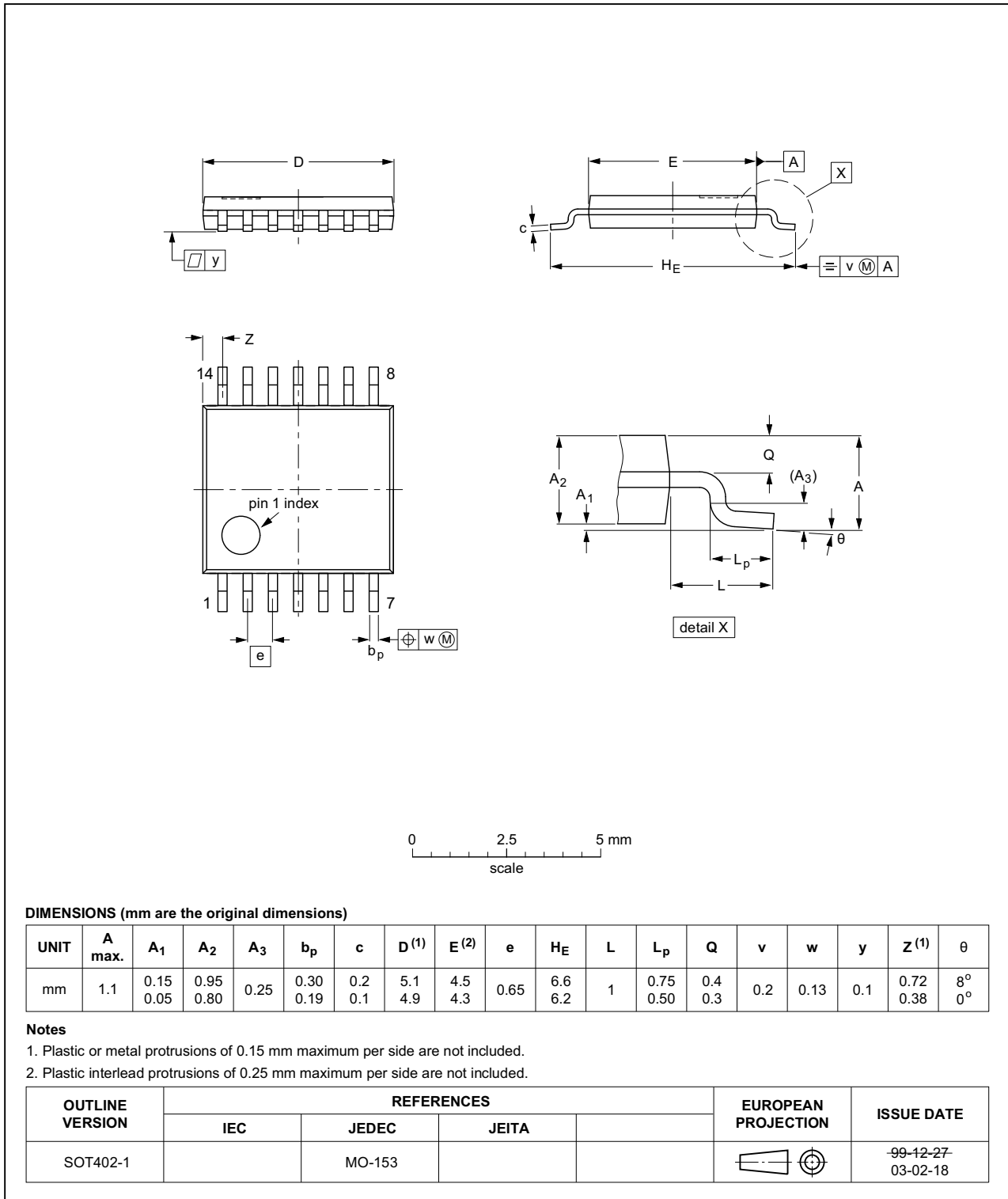

Fig 41. Package outline SOT402-1 (TSSOP14) of PCF8523TS

16. Bare die outline

Bare die; 12 bumps (6-6)

PCF8523U

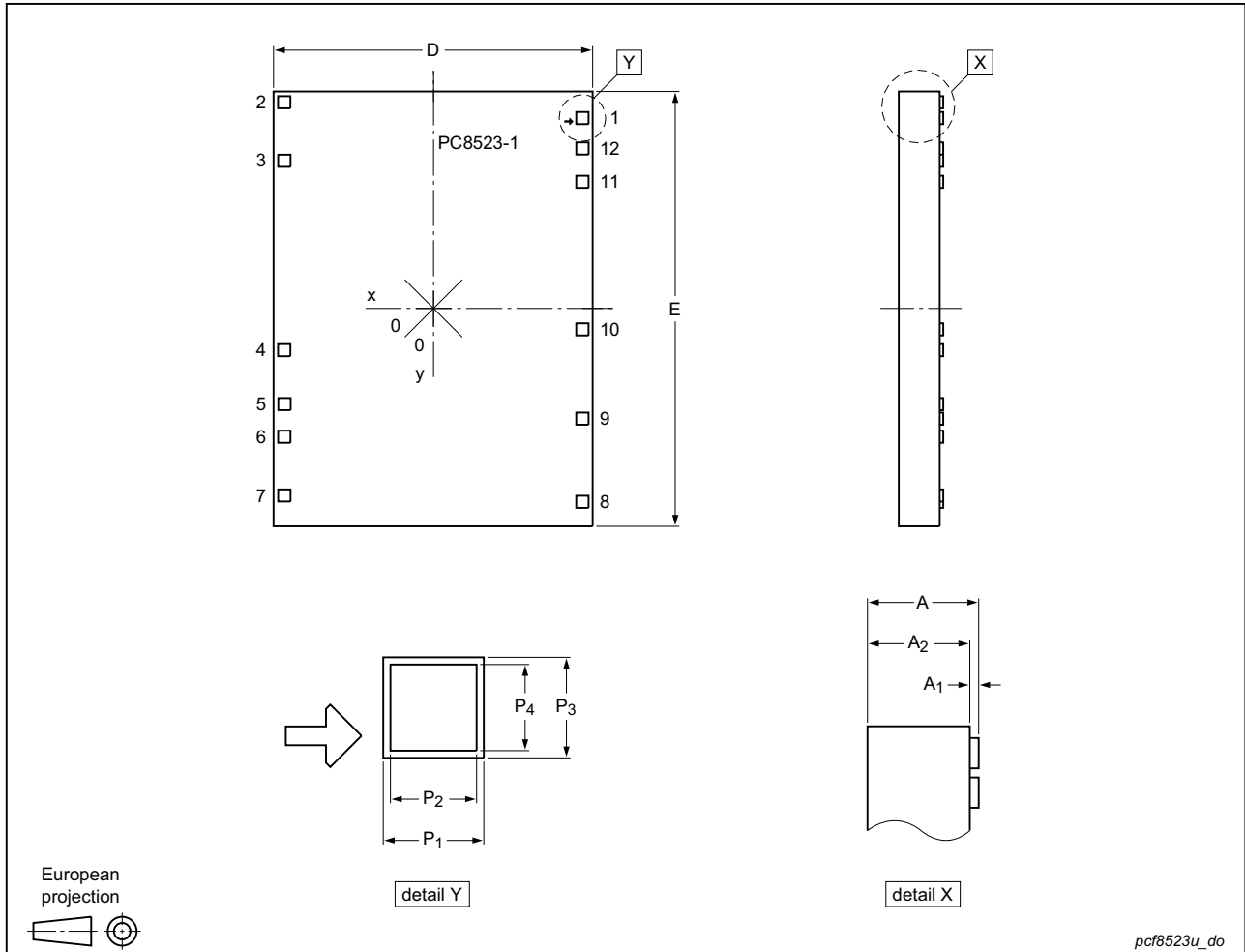

Fig 42. Bare die outline of PCF8523U

Table 50. Dimensions of PCF8523U

Original dimensions are in mm.

| Unit (mm) | A | A ₁ | A ₂ | D ^[1] | E ^[1] | P ₁ ^[2] | P ₂ ^[3] | P ₃ ^[2] | P ₄ ^[3] | Bump pitch |
|-----------|------|----------------|----------------|------------------|------------------|-------------------------------|-------------------------------|-------------------------------|-------------------------------|------------|
| max | - | 0.018 | - | - | - | - | 0.059 | - | 0.059 | - |
| nom | 0.22 | 0.015 | 0.2 | 1.58 | 2.15 | 0.065 | 0.056 | 0.065 | 0.056 | - |
| min | - | 0.012 | - | - | - | - | 0.053 | - | 0.053 | 0.149 |

[1] Dimension includes saw lane.

[2] P₁ and P₃: pad size.

[3] P₂ and P₄: bump size.

Table 51. Bump locations

All x/y coordinates represent the position of the center of each bump with respect to the center (x/y = 0) of the chip; see [Figure 42](#).

| Symbol | Bump | Coordinates (μm) | |
|------------------|------|------------------|--------|
| | | X | Y |
| V _{DD} | 1 | 714.4 | 911.7 |
| OSCI | 2 | -714.4 | 988.3 |
| OSCO | 3 | -714.4 | 707.3 |
| V _{BAT} | 4 | -714.4 | -199.3 |
| V _{SS} | 5 | -714.4 | -459.1 |
| n.c. | 6 | -714.4 | -616.7 |
| INT2 | 7 | -714.4 | -895.4 |
| CLKOUT | 8 | 714.4 | -922.0 |
| SDA | 9 | 714.4 | -528.8 |
| SCL | 10 | 714.4 | -101.1 |
| n.c. | 11 | 714.4 | 607.6 |
| INT1/CLKOUT | 12 | 714.4 | 763.2 |

Table 52. Alignment mark dimension and location

| Coordinates | X | Y |
|--------------------------|----------|----------|
| Location ^[1] | 631.3 μm | 891.7 μm |
| Dimension ^[2] | 44.25 μm | 36.5 μm |

- [1] The x/y coordinates of the alignment mark location represent the position of the REF point (see [Figure 43](#)) with respect to the center (x/y = 0) of the chip; see [Figure 42](#).
- [2] The x/y values of the dimensions represent the extensions of the alignment mark in direction of the coordinate axis (see [Figure 43](#)).

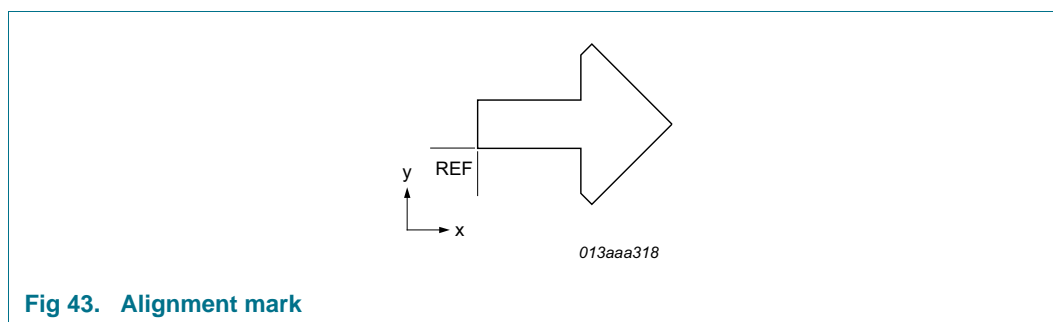

Fig 43. Alignment mark

Table 53. Gold bump hardness of PCF8523U

| Gold bump type | Min | Max | Unit ^[1] |
|----------------|-----|-----|---------------------|
| soft gold bump | 35 | 80 | HV |

- [1] Pressure of diamond head: 10 g to 50 g.

17. Handling information

All input and output pins are protected against ElectroStatic Discharge (ESD) under normal handling. When handling Metal-Oxide Semiconductor (MOS) devices ensure that all normal precautions are taken as described in *JESD625-A*, *IEC 61340-5* or equivalent standards.

18. Packing information

18.1 Tape and reel information

For tape and reel packing information, see

- [Ref. 12 "SOT96-1_118"](#) for PCF8523T
- [Ref. 13 "SOT402-1_118"](#) for PCF8523TS
- [Ref. 14 "SOT909-1_118"](#) for PCF8523TK

18.2 Wafer and Film Frame Carrier (FFC) information for PCF8523U

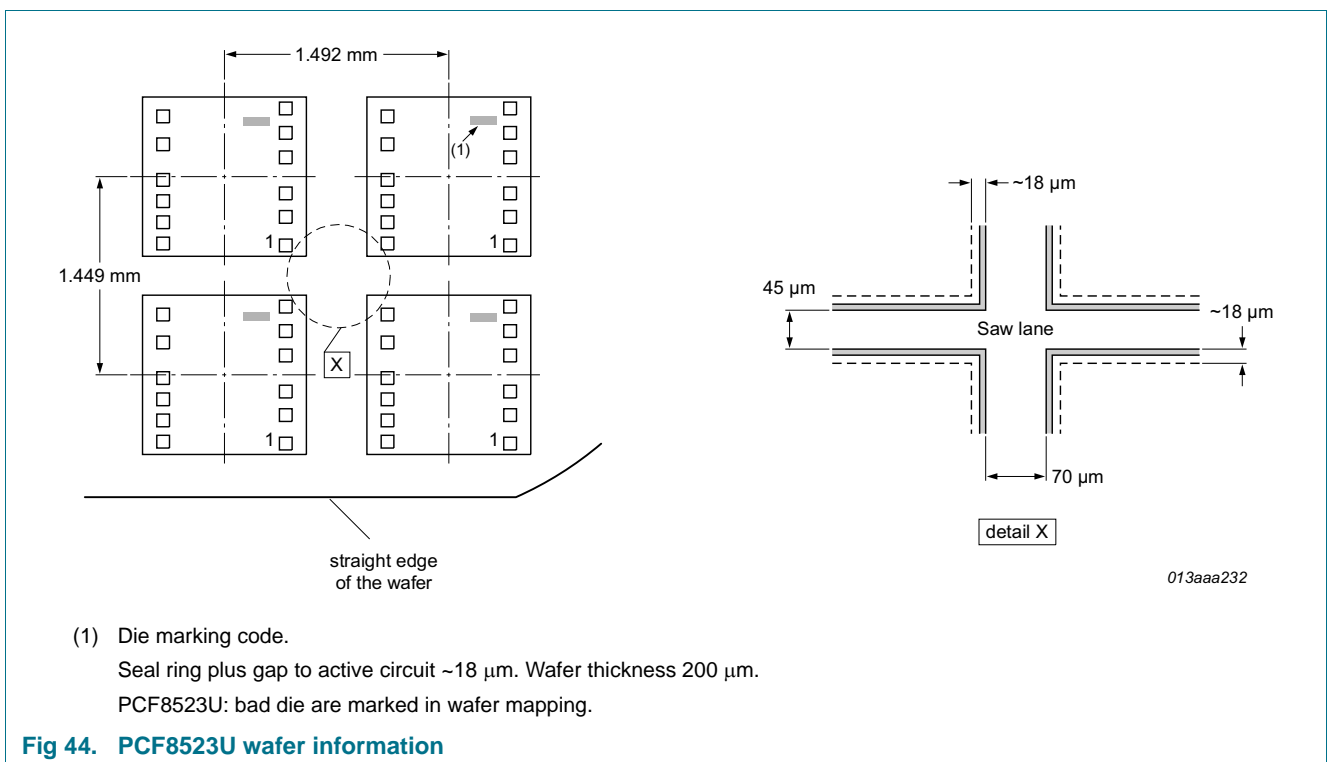

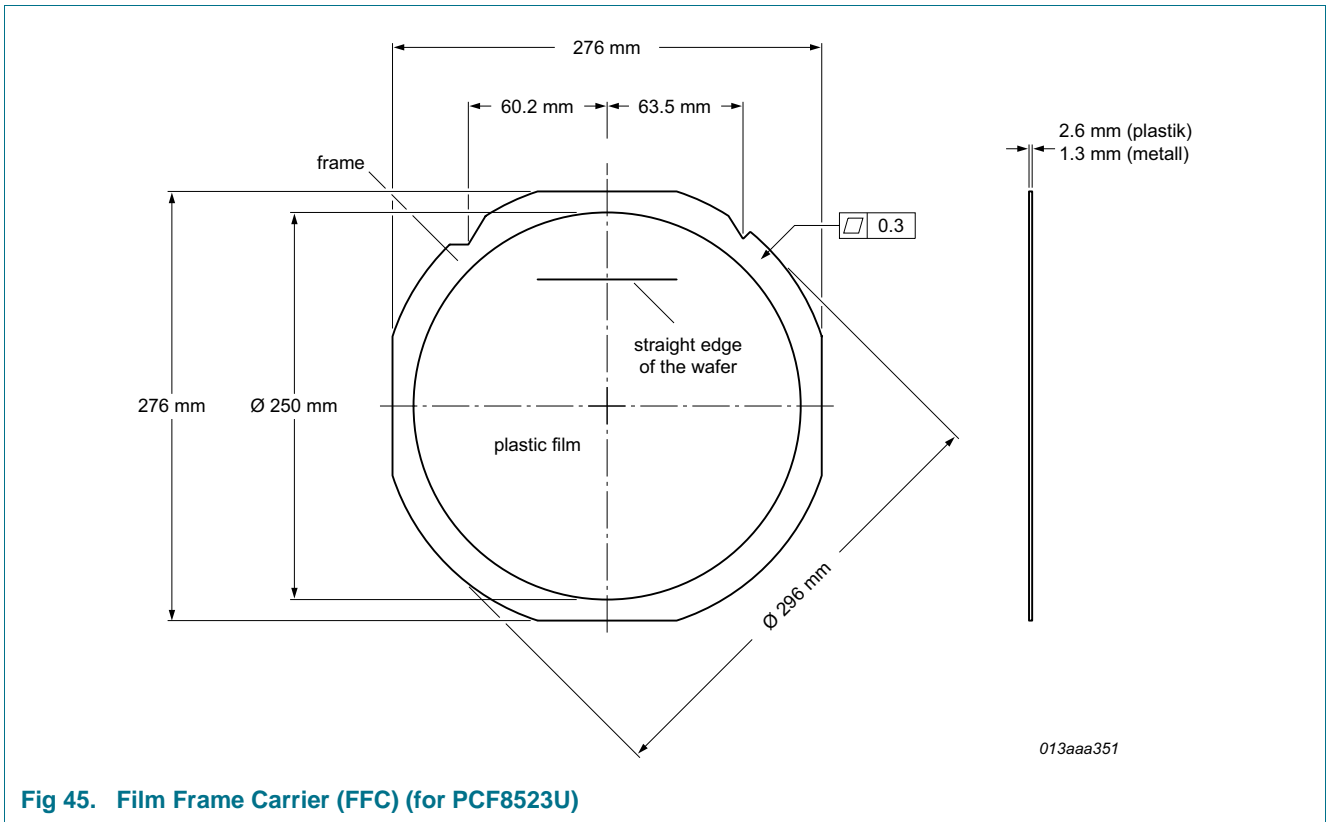

19. Soldering of SMD packages

This text provides a very brief insight into a complex technology. A more in-depth account of soldering ICs can be found in Application Note *AN10365 "Surface mount reflow soldering description"*.

19.1 Introduction to soldering

Soldering is one of the most common methods through which packages are attached to Printed Circuit Boards (PCBs), to form electrical circuits. The soldered joint provides both the mechanical and the electrical connection. There is no single soldering method that is ideal for all IC packages. Wave soldering is often preferred when through-hole and Surface Mount Devices (SMDs) are mixed on one printed wiring board; however, it is not suitable for fine pitch SMDs. Reflow soldering is ideal for the small pitches and high densities that come with increased miniaturization.

19.2 Wave and reflow soldering

Wave soldering is a joining technology in which the joints are made by solder coming from a standing wave of liquid solder. The wave soldering process is suitable for the following:

- Through-hole components
- Leaded or leadless SMDs, which are glued to the surface of the printed circuit board

Not all SMDs can be wave soldered. Packages with solder balls, and some leadless packages which have solder lands underneath the body, cannot be wave soldered. Also, leaded SMDs with leads having a pitch smaller than ~0.6 mm cannot be wave soldered, due to an increased probability of bridging.

The reflow soldering process involves applying solder paste to a board, followed by component placement and exposure to a temperature profile. Leaded packages, packages with solder balls, and leadless packages are all reflow solderable.

Key characteristics in both wave and reflow soldering are:

- Board specifications, including the board finish, solder masks and vias
- Package footprints, including solder thieves and orientation
- The moisture sensitivity level of the packages
- Package placement
- Inspection and repair
- Lead-free soldering versus SnPb soldering

19.3 Wave soldering

Key characteristics in wave soldering are:

- Process issues, such as application of adhesive and flux, clinching of leads, board transport, the solder wave parameters, and the time during which components are exposed to the wave
- Solder bath specifications, including temperature and impurities

19.4 Reflow soldering

Key characteristics in reflow soldering are:

- Lead-free versus SnPb soldering; note that a lead-free reflow process usually leads to higher minimum peak temperatures (see [Figure 46](#)) than a SnPb process, thus reducing the process window
- Solder paste printing issues including smearing, release, and adjusting the process window for a mix of large and small components on one board
- Reflow temperature profile; this profile includes preheat, reflow (in which the board is heated to the peak temperature) and cooling down. It is imperative that the peak temperature is high enough for the solder to make reliable solder joints (a solder paste characteristic). In addition, the peak temperature must be low enough that the packages and/or boards are not damaged. The peak temperature of the package depends on package thickness and volume and is classified in accordance with [Table 54](#) and [55](#)

Table 54. SnPb eutectic process (from J-STD-020D)

| Package thickness (mm) | Package reflow temperature (°C) | |
|------------------------|---------------------------------|-------|
| | Volume (mm ³) | |
| | < 350 | ≥ 350 |
| < 2.5 | 235 | 220 |
| ≥ 2.5 | 220 | 220 |

Table 55. Lead-free process (from J-STD-020D)

| Package thickness (mm) | Package reflow temperature (°C) | | |
|------------------------|---------------------------------|-------------|--------|
| | Volume (mm ³) | | |
| | < 350 | 350 to 2000 | > 2000 |
| < 1.6 | 260 | 260 | 260 |
| 1.6 to 2.5 | 260 | 250 | 245 |
| > 2.5 | 250 | 245 | 245 |

Moisture sensitivity precautions, as indicated on the packing, must be respected at all times.

Studies have shown that small packages reach higher temperatures during reflow soldering, see [Figure 46](#).

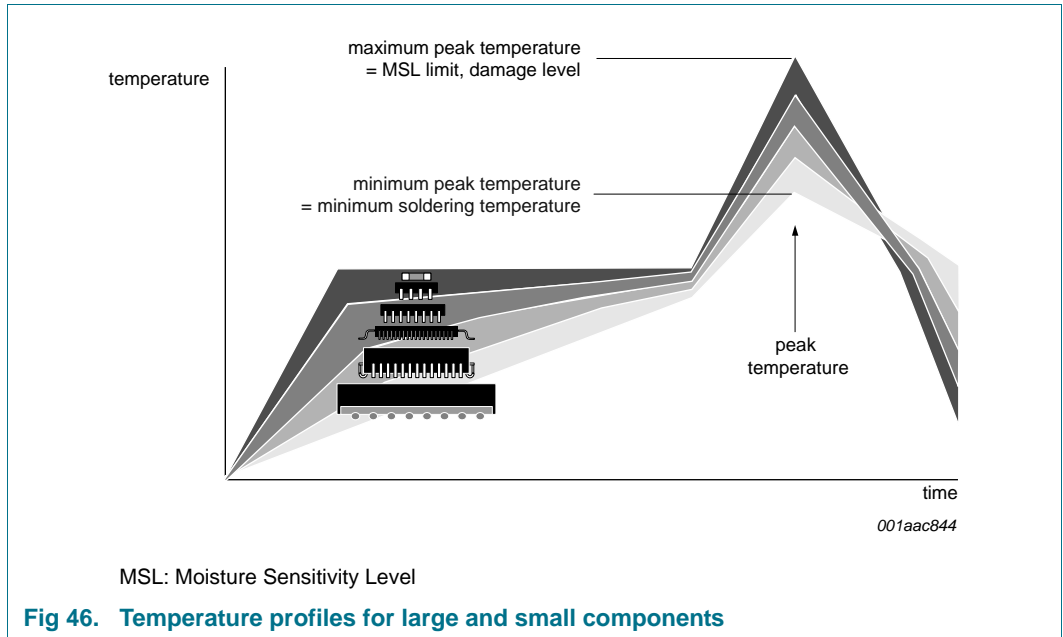

For further information on temperature profiles, refer to Application Note AN10365 “Surface mount reflow soldering description”.

20. Footprint information

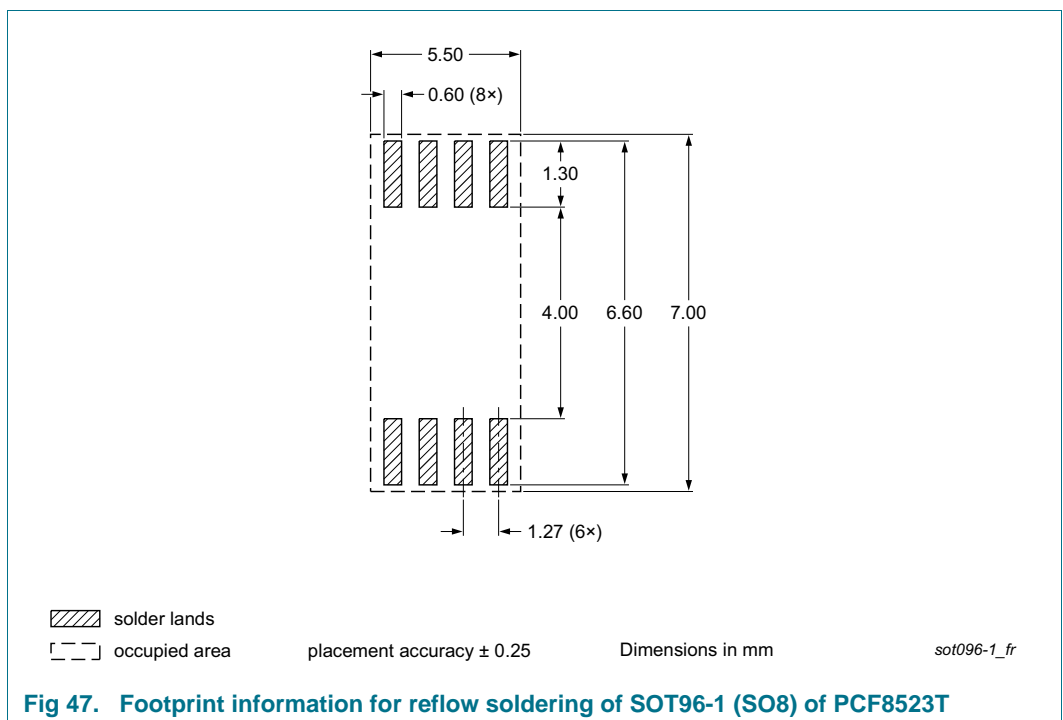

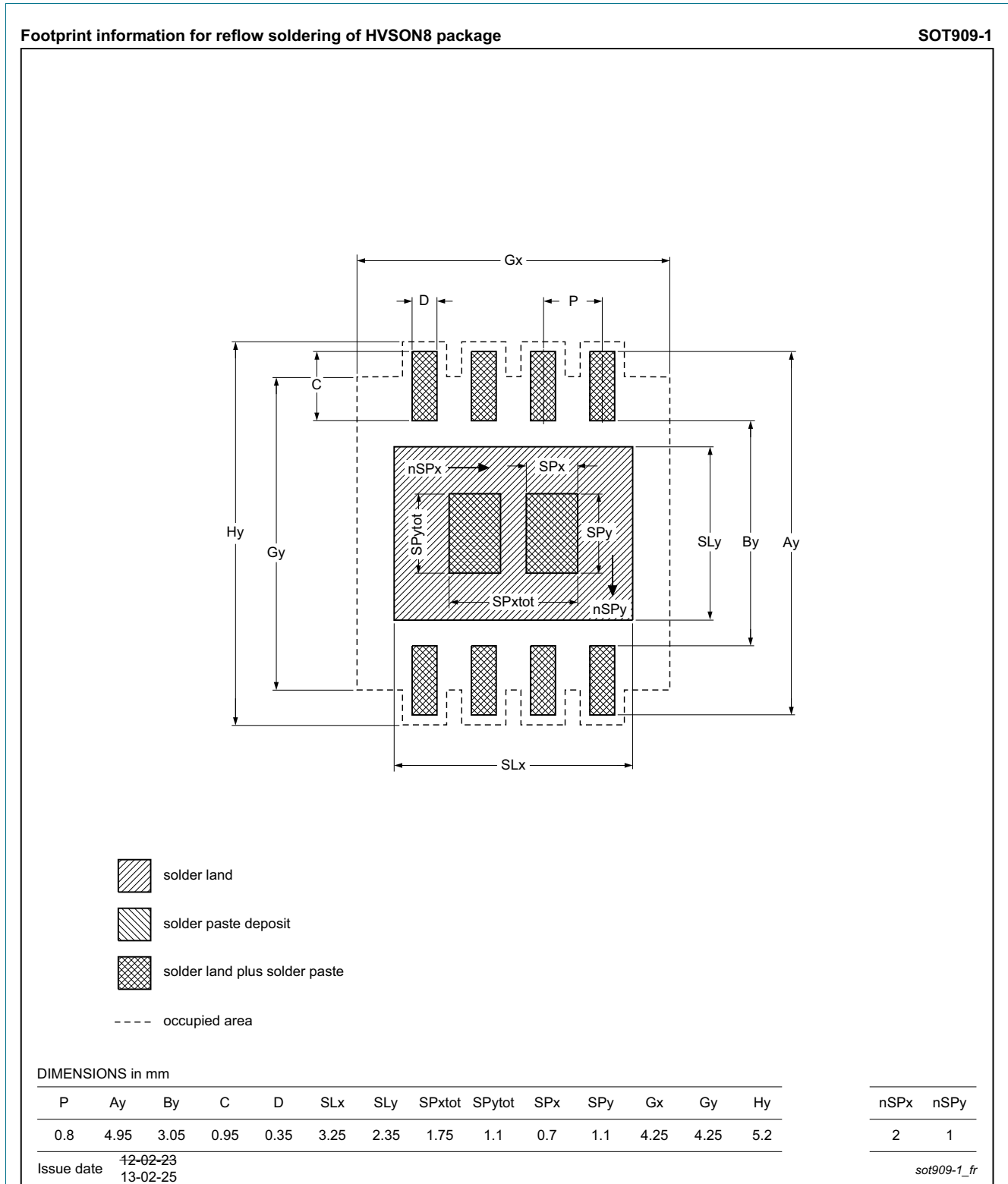
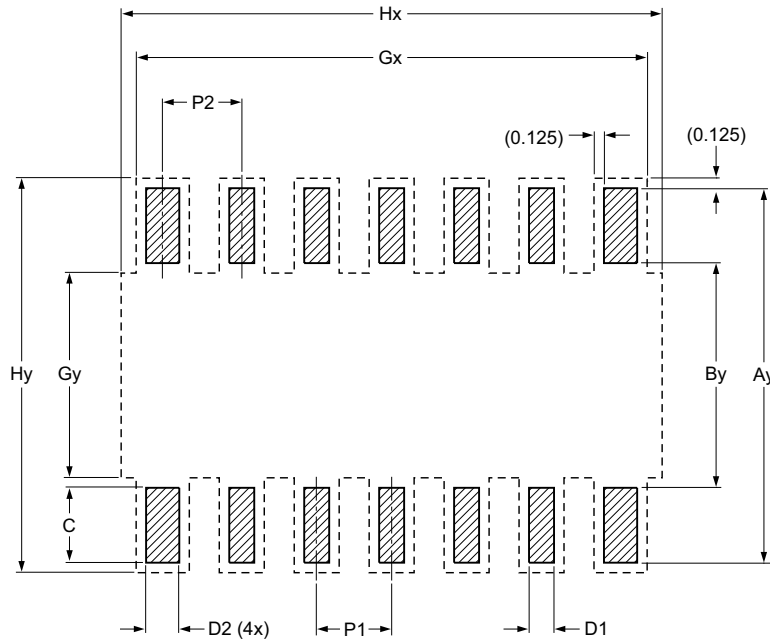



Fig 48. Footprint information for reflow soldering of SOT909-1 (HVSON8) of PCF8523TK

Footprint information for reflow soldering of TSSOP14 package

SOT402-1



Generic footprint pattern
Refer to the package outline drawing for actual layout

 solder land
- - - - occupied area

DIMENSIONS in mm

| P1 | P2 | Ay | By | C | D1 | D2 | Gx | Gy | Hx | Hy |
|-------|-------|-------|-------|-------|-------|-------|-------|-------|-------|-------|
| 0.650 | 0.750 | 7.200 | 4.500 | 1.350 | 0.400 | 0.600 | 4.950 | 5.300 | 5.800 | 7.450 |

sol402-1_fr

Fig 49. Footprint information for reflow soldering of SOT402-1 (TSSOP14) of PCF8523TS

21. Appendix

21.1 Real-Time Clock selection

Table 56. Selection of Real-Time Clocks

| Type name | Alarm, Timer, Watchdog | Interrupt output | Interface | I _{DD} , typical (nA) | Battery backup | Timestamp, tamper input | AEC-Q100 compliant | Special features |
|------------|------------------------|------------------|------------------|--------------------------------|----------------|-------------------------|--------------------|-----------------------------------------------------------|
| PCF85063TP | - | 1 | I ² C | 220 | - | - | - | basic functions only alarm |
| PCF85063A | X | 1 | I ² C | 220 | - | - | - | tiny package |
| PCF85063B | X | 1 | SPI | 220 | - | - | - | tiny package |
| PCF85263A | X | 2 | I ² C | 230 | X | X | - | time stamp, battery backup, stopwatch |
| PCF85263B | X | 2 | SPI | 230 | X | X | - | time stamp, battery backup, stopwatch |
| PCF85363A | X | 2 | I ² C | 230 | X | X | - | time stamp, battery backup, stopwatch 64 Byte RAM |
| PCF85363B | X | 2 | SPI | 230 | X | X | - | time stamp, battery backup, stopwatch 64 Byte RAM |
| PCF2123 | X | 1 | SPI | 100 | - | - | - | lowest power 100 nA operation |
| PCF8523 | X | 2 | I ² C | 150 | X | - | - | lowest power 150 nA operation, FM+ 1 M |
| PCF8563 | X | 1 | I ² C | 250 | - | - | - | - |
| PCA8565 | X | 1 | I ² C | 600 | - | - | grade 1 | high robustness, T _{amb} = -40 °C to 125 |
| PCA8565A | X | 1 | I ² C | 600 | - | - | - | integrated oscillator T _{amb} = -40 °C to 125 |
| PCF8564A | X | 1 | I ² C | 250 | - | - | - | integrated oscillator |

Table 56. Selection of Real-Time Clocks ...continued

| Type name | Alarm, Timer, Watchdog | Interrupt output | Interface | I _{DD} , typical (nA) | Battery backup | Timestamp, tamper input | AEC-Q100 compliant | Special features |
|-----------|------------------------|------------------|--------------------------|--------------------------------|----------------|-------------------------|--------------------|------------------------------------------------------------|
| PCF2127 | X | 1 | I ² C and SPI | 500 | X | X | - | temperature compensated, quartz, in, calibrated, 512 B RAM |
| PCF2127A | X | 1 | I ² C and SPI | 500 | X | X | - | temperature compensated, quartz, in, calibrated, 512 B RAM |
| PCF2129 | X | 1 | I ² C and SPI | 500 | X | X | - | temperature compensated, quartz, in, calibrated |
| PCF2129A | X | 1 | I ² C and SPI | 500 | X | X | - | temperature compensated, quartz, in, calibrated |
| PCA2129 | X | 1 | I ² C and SPI | 500 | X | X | grade 3 | temperature compensated, quartz, in, calibrated |
| PCA21125 | X | 1 | SPI | 820 | - | - | grade 1 | high robustness, T _{amb} = -40 °C to 125 °C |

22. Abbreviations

Table 57. Abbreviations

| Acronym | Description |
|------------------|-----------------------------------------|
| AM | Ante Meridiem |
| BCD | Binary Coded Decimal |
| CDM | Charged-Device Model |
| CMOS | Complementary Metal-Oxide Semiconductor |
| DC | Direct Current |
| FFC | Film Frame Carrier |
| HBM | Human Body Model |
| I ² C | Inter-Integrated Circuit bus |
| IC | Integrated Circuit |
| LSB | Least Significant Bit |
| MCU | Microcontroller Unit |
| MSB | Most Significant Bit |
| MSL | Moisture Sensitivity Level |
| PCB | Printed-Circuit Board |
| PM | Post Meridiem |
| POR | Power-On Reset |
| RTC | Real-Time Clock |
| SCL | Serial CLock line |
| SDA | Serial DAta line |
| SMD | Surface Mount Device |
| SR | Slew Rate |

23. References

- [1] **AN10365** — Surface mount reflow soldering description
- [2] **AN10706** — Handling bare die
- [3] **AN10853** — ESD and EMC sensitivity of IC
- [4] **AN11247** — Improved timekeeping accuracy with PCF85063, PCF8523 and PCF2123 using an external temperature sensor
- [5] **IEC 60134** — Rating systems for electronic tubes and valves and analogous semiconductor devices
- [6] **IEC 61340-5** — Protection of electronic devices from electrostatic phenomena
- [7] **IPC/JEDEC J-STD-020D** — Moisture/Reflow Sensitivity Classification for Nonhermetic Solid State Surface Mount Devices
- [8] **JESD22-A114** — Electrostatic Discharge (ESD) Sensitivity Testing Human Body Model (HBM)
- [9] **JESD22-C101** — Field-Induced Charged-Device Model Test Method for Electrostatic-Discharge-Withstand Thresholds of Microelectronic Components
- [10] **JESD78** — IC Latch-Up Test
- [11] **JESD625-A** — Requirements for Handling Electrostatic-Discharge-Sensitive (ESDS) Devices
- [12] **SOT96-1_118** — SO8; Reel pack; SMD, 13", packing information
- [13] **SOT402-1_118** — TSSOP14; Reel pack; SMD, 13", packing information
- [14] **SOT909-1_118** — HVSON8; Reel pack; SMD, 13", packing information
- [15] **UM10204** — I²C-bus specification and user manual
- [16] **UM10301** — User Manual for NXP Real Time Clocks PCF85x3, PCA8565 and PCF2123, PCA21125
- [17] **UM10569** — Store and transport requirements
- [18] **UM10760** — User manual for the I²C-bus RTC PCF8523 demo board OM13511

24. Revision history

Table 58. Revision history

| Document ID | Release date | Data sheet status | Change notice | Supersedes |
|----------------|-------------------------------------------------------------------------------------------------------------------------------------------------------------------------------------------------------------------------------------------------------------------------------------------------------------------------------------------------------------------------------------|--------------------|---------------|-------------|
| PCF8523 v.7 | 20150428 | Product data sheet | - | PCF8523 v.6 |
| Modifications: | <ul style="list-style-type: none"> • The format of this data sheet has been redesigned to comply with the new identity guidelines of NXP Semiconductors. • Legal texts have been adapted to the new company name where appropriate. • Adjusted slew rate specification in Table 48 • Updated Section 18.1 | | | |
| PCF8523 v.6 | 20130917 | Product data sheet | - | PCF8523 v.5 |
| PCF8523 v.5 | 20130318 | Product data sheet | - | PCF8523 v.4 |
| PCF8523 v.4 | 20120705 | Product data sheet | - | PCF8523 v.3 |
| PCF8523 v.3 | 20110330 | Product data sheet | - | PCF8523 v.2 |
| PCF8523 v.2 | 20110127 | Product data sheet | - | PCF8523 v.1 |
| PCF8523 v.1 | 20101123 | Product data sheet | - | - |

25. Legal information

25.1 Data sheet status

| Document status ^{[1][2]} | Product status ^[3] | Definition |
|-----------------------------------|-------------------------------|---------------------------------------------------------------------------------------|
| Objective [short] data sheet | Development | This document contains data from the objective specification for product development. |
| Preliminary [short] data sheet | Qualification | This document contains data from the preliminary specification. |
| Product [short] data sheet | Production | This document contains the product specification. |

[1] Please consult the most recently issued document before initiating or completing a design.

[2] The term 'short data sheet' is explained in section "Definitions".

[3] The product status of device(s) described in this document may have changed since this document was published and may differ in case of multiple devices. The latest product status information is available on the Internet at URL <http://www.nxp.com>.

25.2 Definitions

Draft — The document is a draft version only. The content is still under internal review and subject to formal approval, which may result in modifications or additions. NXP Semiconductors does not give any representations or warranties as to the accuracy or completeness of information included herein and shall have no liability for the consequences of use of such information.

Short data sheet — A short data sheet is an extract from a full data sheet with the same product type number(s) and title. A short data sheet is intended for quick reference only and should not be relied upon to contain detailed and full information. For detailed and full information see the relevant full data sheet, which is available on request via the local NXP Semiconductors sales office. In case of any inconsistency or conflict with the short data sheet, the full data sheet shall prevail.

Product specification — The information and data provided in a Product data sheet shall define the specification of the product as agreed between NXP Semiconductors and its customer, unless NXP Semiconductors and customer have explicitly agreed otherwise in writing. In no event however, shall an agreement be valid in which the NXP Semiconductors product is deemed to offer functions and qualities beyond those described in the Product data sheet.

25.3 Disclaimers

Limited warranty and liability — Information in this document is believed to be accurate and reliable. However, NXP Semiconductors does not give any representations or warranties, expressed or implied, as to the accuracy or completeness of such information and shall have no liability for the consequences of use of such information. NXP Semiconductors takes no responsibility for the content in this document if provided by an information source outside of NXP Semiconductors.

In no event shall NXP Semiconductors be liable for any indirect, incidental, punitive, special or consequential damages (including - without limitation - lost profits, lost savings, business interruption, costs related to the removal or replacement of any products or rework charges) whether or not such damages are based on tort (including negligence), warranty, breach of contract or any other legal theory.

Notwithstanding any damages that customer might incur for any reason whatsoever, NXP Semiconductors' aggregate and cumulative liability towards customer for the products described herein shall be limited in accordance with the *Terms and conditions of commercial sale* of NXP Semiconductors.

Right to make changes — NXP Semiconductors reserves the right to make changes to information published in this document, including without limitation specifications and product descriptions, at any time and without notice. This document supersedes and replaces all information supplied prior to the publication hereof.

Suitability for use — NXP Semiconductors products are not designed, authorized or warranted to be suitable for use in life support, life-critical or safety-critical systems or equipment, nor in applications where failure or malfunction of an NXP Semiconductors product can reasonably be expected to result in personal injury, death or severe property or environmental damage. NXP Semiconductors and its suppliers accept no liability for inclusion and/or use of NXP Semiconductors products in such equipment or applications and therefore such inclusion and/or use is at the customer's own risk.

Applications — Applications that are described herein for any of these products are for illustrative purposes only. NXP Semiconductors makes no representation or warranty that such applications will be suitable for the specified use without further testing or modification.

Customers are responsible for the design and operation of their applications and products using NXP Semiconductors products, and NXP Semiconductors accepts no liability for any assistance with applications or customer product design. It is customer's sole responsibility to determine whether the NXP Semiconductors product is suitable and fit for the customer's applications and products planned, as well as for the planned application and use of customer's third party customer(s). Customers should provide appropriate design and operating safeguards to minimize the risks associated with their applications and products.

NXP Semiconductors does not accept any liability related to any default, damage, costs or problem which is based on any weakness or default in the customer's applications or products, or the application or use by customer's third party customer(s). Customer is responsible for doing all necessary testing for the customer's applications and products using NXP Semiconductors products in order to avoid a default of the applications and the products or of the application or use by customer's third party customer(s). NXP does not accept any liability in this respect.

Limiting values — Stress above one or more limiting values (as defined in the Absolute Maximum Ratings System of IEC 60134) will cause permanent damage to the device. Limiting values are stress ratings only and (proper) operation of the device at these or any other conditions above those given in the Recommended operating conditions section (if present) or the Characteristics sections of this document is not warranted. Constant or repeated exposure to limiting values will permanently and irreversibly affect the quality and reliability of the device.

Terms and conditions of commercial sale — NXP Semiconductors products are sold subject to the general terms and conditions of commercial sale, as published at <http://www.nxp.com/profile/terms>, unless otherwise agreed in a valid written individual agreement. In case an individual agreement is concluded only the terms and conditions of the respective agreement shall apply. NXP Semiconductors hereby expressly objects to applying the customer's general terms and conditions with regard to the purchase of NXP Semiconductors products by customer.

No offer to sell or license — Nothing in this document may be interpreted or construed as an offer to sell products that is open for acceptance or the grant, conveyance or implication of any license under any copyrights, patents or other industrial or intellectual property rights.

Export control — This document as well as the item(s) described herein may be subject to export control regulations. Export might require a prior authorization from competent authorities.

Non-automotive qualified products — Unless this data sheet expressly states that this specific NXP Semiconductors product is automotive qualified, the product is not suitable for automotive use. It is neither qualified nor tested in accordance with automotive testing or application requirements. NXP Semiconductors accepts no liability for inclusion and/or use of non-automotive qualified products in automotive equipment or applications.

In the event that customer uses the product for design-in and use in automotive applications to automotive specifications and standards, customer (a) shall use the product without NXP Semiconductors' warranty of the product for such automotive applications, use and specifications, and (b) whenever customer uses the product for automotive applications beyond NXP Semiconductors' specifications such use shall be solely at customer's own risk, and (c) customer fully indemnifies NXP Semiconductors for any liability, damages or failed product claims resulting from customer design and use of the product for automotive applications beyond NXP Semiconductors' standard warranty and NXP Semiconductors' product specifications.

Translations — A non-English (translated) version of a document is for reference only. The English version shall prevail in case of any discrepancy between the translated and English versions.

Bare die — All die are tested on compliance with their related technical specifications as stated in this data sheet up to the point of wafer sawing and are handled in accordance with the NXP Semiconductors storage and transportation conditions. If there are data sheet limits not guaranteed, these will be separately indicated in the data sheet. There are no post-packing tests performed on individual die or wafers.

NXP Semiconductors has no control of third party procedures in the sawing, handling, packing or assembly of the die. Accordingly, NXP Semiconductors assumes no liability for device functionality or performance of the die or systems after third party sawing, handling, packing or assembly of the die. It is the responsibility of the customer to test and qualify their application in which the die is used.

All die sales are conditioned upon and subject to the customer entering into a written die sale agreement with NXP Semiconductors through its legal department.

25.4 Trademarks

Notice: All referenced brands, product names, service names and trademarks are the property of their respective owners.

I²C-bus — logo is a trademark of NXP Semiconductors N.V.

26. Contact information

For more information, please visit: <http://www.nxp.com>

For sales office addresses, please send an email to: salesaddresses@nxp.com

27. Tables

| | | | |
|------------------------------------------------------------------------------------------------------------|----|-----------------------------------------------------------------------------------------|----|
| Table 1. Ordering information | 2 | Table 39. Tmr_B_reg - timer B value register (address 13h) bit description | 34 |
| Table 2. Ordering options | 2 | Table 40. Programmable timer characteristics | 34 |
| Table 3. PCF8523U wafer information | 2 | Table 41. First period delay for timer counter value T_A | 37 |
| Table 4. Marking codes | 2 | Table 42. Effect of bit SIE on INT1 and bit SF | 39 |
| Table 5. Pin description | 5 | Table 43. Interrupt low pulse width for timer A | 40 |
| Table 6. Registers overview | 7 | Table 44. Interrupt low pulse width for timer B | 41 |
| Table 7. Control_1 - control and status register 1 (address 00h) bit description | 9 | Table 45. First increment of time circuits after STOP release | 44 |
| Table 8. Control_2 - control and status register 2 (address 01h) bit description | 10 | Table 46. I ² C slave address byte | 46 |
| Table 9. Control_3 - control and status register 3 (address 02h) bit description | 11 | Table 47. Limiting values | 49 |
| Table 10. Register reset values | 12 | Table 48. Static characteristics | 50 |
| Table 11. Power management function control bits | 15 | Table 49. I ² C-bus interface timing | 52 |
| Table 12. Seconds - seconds and clock integrity status register (address 03h) bit description | 20 | Table 50. Dimensions of PCF8523U | 59 |
| Table 13. SECONDS coded in BCD format | 20 | Table 51. Bump locations | 60 |
| Table 14. Minutes - minutes register (address 04h) bit description | 21 | Table 52. Alignment mark dimension and location | 60 |
| Table 15. Hours - hours register (address 05h) bit description | 21 | Table 53. Gold bump hardness of PCF8523U | 60 |
| Table 16. Days - days register (address 06h) bit description | 21 | Table 54. SnPb eutectic process (from J-STD-020D) | 64 |
| Table 17. Weekdays - weekdays register (address 07h) bit description | 22 | Table 55. Lead-free process (from J-STD-020D) | 64 |
| Table 18. Weekday assignments | 22 | Table 56. Selection of Real-Time Clocks | 68 |
| Table 19. Months - months register (address 08h) bit description | 22 | Table 57. Abbreviations | 70 |
| Table 20. Month assignments in BCD format | 22 | Table 58. Revision history | 72 |
| Table 21. Years - years register (09h) bit description | 23 | | |
| Table 22. Minute_alarm - minute alarm register (address 0Ah) bit description | 24 | | |
| Table 23. Hour_alarm - hour alarm register (address 0Bh) bit description | 24 | | |
| Table 24. Day_alarm - day alarm register (address 0Ch) bit description | 25 | | |
| Table 25. Weekday_alarm - weekday alarm register (address 0Dh) bit description | 25 | | |
| Table 26. Flag location in register Control_2 | 26 | | |
| Table 27. Example to clear only AF (bit 3) | 26 | | |
| Table 28. Offset - offset register (address 0Eh) bit description | 28 | | |
| Table 29. Offset values (in period time, not frequency) | 28 | | |
| Table 30. Correction pulses for MODE = 0 | 29 | | |
| Table 31. Effect of clock correction for MODE = 0 | 29 | | |
| Table 32. Correction pulses for MODE = 1 | 30 | | |
| Table 33. Effect of clock correction for MODE = 1 | 30 | | |
| Table 34. Tmr_CLKOUT_ctrl - timer and CLKOUT control register (address 0Fh) bit description | 32 | | |
| Table 35. CLKOUT frequency selection | 33 | | |
| Table 36. Tmr_A_freq_ctrl - timer A frequency control register (address 10h) bit description | 33 | | |
| Table 37. Tmr_A_reg - timer A value register (address 11h) bit description | 33 | | |
| Table 38. Tmr_B_freq_ctrl - timer B frequency control register (address 12h) bit description | 34 | | |

28. Figures

| | | | |
|-----------------------------------------------------------------------------------------------------------------|----|------------------------------------------------------------------------------------------------|----|
| Fig 1. Block diagram of PCF8523 | 3 | Fig 46. Temperature profiles for large and small components. | 65 |
| Fig 2. Pin configuration for SO8 (PCF8523T) | 4 | Fig 47. Footprint information for reflow soldering of SOT96-1 (SO8) of PCF8523T. | 65 |
| Fig 3. Pin configuration for HVSON8 (PCF8523TK) | 4 | Fig 48. Footprint information for reflow soldering of SOT909-1 (HVSON8) of PCF8523TK. | 66 |
| Fig 4. Pin configuration for TSSOP14 (PCF8523TS). | 4 | Fig 49. Footprint information for reflow soldering of SOT402-1 (TSSOP14) of PCF8523TS. | 67 |
| Fig 5. Pin configuration for PCF8523U | 5 | | |
| Fig 6. Auto-incrementing of the registers. | 7 | | |
| Fig 7. Software reset command. | 12 | | |
| Fig 8. Interrupt block diagram | 14 | | |
| Fig 9. Battery switch-over behavior in standard mode and with bit BSIE set logic 1 (enabled) | 17 | | |
| Fig 10. Battery switch-over behavior in direct switching mode and with bit BSIE set logic 1 (enabled) | 18 | | |
| Fig 11. Battery low detection behavior with bit BLIE set logic 1 (enabled) | 19 | | |
| Fig 12. OS flag. | 21 | | |
| Fig 13. Data flow diagram of the time function. | 23 | | |
| Fig 14. Access time for read/write operations | 23 | | |
| Fig 15. Alarm function block diagram. | 25 | | |
| Fig 16. Alarm flag timing | 26 | | |
| Fig 17. AF timing | 27 | | |
| Fig 18. Offset calibration calculation workflow. | 31 | | |
| Fig 19. Watchdog activates an interrupt when timed out | 36 | | |
| Fig 20. General countdown timer behavior | 37 | | |
| Fig 21. General countdown timer behavior | 38 | | |
| Fig 22. Example for second interrupt when TAM = 1. | 40 | | |
| Fig 23. Example for second interrupt when TAM = 0. | 40 | | |
| Fig 24. Example of shortening the INT1 pulse by clearing the SF flag | 41 | | |
| Fig 25. Example of shortening the INT1 pulse by clearing the CTAF flag | 42 | | |
| Fig 26. STOP bit | 43 | | |
| Fig 27. STOP bit release timing. | 43 | | |
| Fig 28. Bit transfer | 45 | | |
| Fig 29. Definition of START and STOP conditions. | 45 | | |
| Fig 30. System configuration | 45 | | |
| Fig 31. Acknowledgement on the I ² C-bus | 46 | | |
| Fig 32. Bus protocol for write mode | 47 | | |
| Fig 33. Bus protocol for read mode | 47 | | |
| Fig 34. Device diode protection diagram of PCF8523 | 47 | | |
| Fig 35. I ² C-bus timing diagram; rise and fall times refer to 30 % and 70 % | 53 | | |
| Fig 36. Supply voltage with respect to sampling and comparing rate. | 53 | | |
| Fig 37. RC network on pin V _{DD} | 54 | | |
| Fig 38. Application diagram | 55 | | |
| Fig 39. Package outline SOT96-1 (SO8) of PCF8523T. | 56 | | |
| Fig 40. Package outline SOT909-1 (HVSON8) of PCF8523TK. | 57 | | |
| Fig 41. Package outline SOT402-1 (TSSOP14) of PCF8523TS. | 58 | | |
| Fig 42. Bare die outline of PCF8523U | 59 | | |
| Fig 43. Alignment mark | 60 | | |
| Fig 44. PCF8523U wafer information. | 61 | | |
| Fig 45. Film Frame Carrier (FFC) (for PCF8523U) | 62 | | |

29. Contents

| | | | | | |
|----------|----------------------------------------------------------------------------------|----------|-----------|-----------------------------------------------------------------------|-----------|
| 1 | General description | 1 | 8.8.3 | Offset calibration workflow | 30 |
| 2 | Features and benefits | 1 | 8.9 | Timer function | 31 |
| 3 | Applications | 1 | 8.9.1 | Timer registers | 32 |
| 4 | Ordering information | 2 | 8.9.1.1 | Register Tmr_CLKOUT_ctrl and clock output | 32 |
| 4.1 | Ordering options | 2 | 8.9.1.2 | CLKOUT frequency selection | 32 |
| 5 | Marking | 2 | 8.9.1.3 | Register Tmr_A_freq_ctrl | 33 |
| 6 | Block diagram | 3 | 8.9.1.4 | Register Tmr_A_reg | 33 |
| 7 | Pinning information | 4 | 8.9.1.5 | Register Tmr_B_freq_ctrl | 34 |
| 7.1 | Pinning | 4 | 8.9.1.6 | Register Tmr_B_reg | 34 |
| 7.2 | Pin description | 5 | 8.9.1.7 | Programmable timer characteristics | 34 |
| 8 | Functional description | 6 | 8.9.2 | Timer A | 35 |
| 8.1 | Registers overview | 7 | 8.9.2.1 | Watchdog timer function | 35 |
| 8.2 | Control and status registers | 9 | 8.9.2.2 | Countdown timer function | 36 |
| 8.2.1 | Register Control_1 | 9 | 8.9.3 | Timer B | 38 |
| 8.2.2 | Register Control_2 | 10 | 8.9.4 | Second interrupt timer | 39 |
| 8.2.3 | Register Control_3 | 11 | 8.9.5 | Timer interrupt pulse | 40 |
| 8.3 | Reset | 12 | 8.10 | STOP bit function | 43 |
| 8.4 | Interrupt function | 13 | 8.11 | I ² C-bus interface | 44 |
| 8.5 | Power management functions | 15 | 8.11.1 | Bit transfer | 44 |
| 8.5.1 | Standby mode | 15 | 8.11.2 | START and STOP conditions | 45 |
| 8.5.2 | Battery switch-over function | 16 | 8.11.3 | System configuration | 45 |
| 8.5.2.1 | Standard mode | 17 | 8.11.4 | Acknowledge | 46 |
| 8.5.2.2 | Direct switching mode | 18 | 8.11.5 | I ² C-bus protocol | 46 |
| 8.5.2.3 | Battery switch-over disabled, only one power supply (V _{DD}) | 18 | 9 | Internal circuitry | 47 |
| 8.5.3 | Battery low detection function | 18 | 10 | Safety notes | 48 |
| 8.6 | Time and date registers | 19 | 11 | Limiting values | 49 |
| 8.6.1 | Register Seconds | 20 | 12 | Static characteristics | 50 |
| 8.6.1.1 | Oscillator STOP flag | 20 | 13 | Dynamic characteristics | 52 |
| 8.6.2 | Register Minutes | 21 | 14 | Application information | 53 |
| 8.6.3 | Register Hours | 21 | 14.1 | Battery switch-over applications | 53 |
| 8.6.4 | Register Days | 21 | 15 | Package outline | 56 |
| 8.6.5 | Register Weekdays | 22 | 16 | Bare die outline | 59 |
| 8.6.6 | Register Months | 22 | 17 | Handling information | 61 |
| 8.6.7 | Register Years | 23 | 18 | Packing information | 61 |
| 8.6.8 | Data flow of the time function | 23 | 18.1 | Tape and reel information | 61 |
| 8.7 | Alarm registers | 24 | 18.2 | Wafer and Film Frame Carrier (FFC) information for PCF8523U | 61 |
| 8.7.1 | Register Minute_alarm | 24 | 19 | Soldering of SMD packages | 63 |
| 8.7.2 | Register Hour_alarm | 24 | 19.1 | Introduction to soldering | 63 |
| 8.7.3 | Register Day_alarm | 25 | 19.2 | Wave and reflow soldering | 63 |
| 8.7.4 | Register Weekday_alarm | 25 | 19.3 | Wave soldering | 63 |
| 8.7.5 | Alarm flag | 25 | 19.4 | Reflow soldering | 64 |
| 8.7.6 | Alarm interrupts | 26 | 20 | Footprint information | 65 |
| 8.8 | Register Offset | 28 | 21 | Appendix | 68 |
| 8.8.1 | Correction when MODE = 0 | 28 | 21.1 | Real-Time Clock selection | 68 |
| 8.8.2 | Correction when MODE = 1 | 29 | | | |

continued >>

| | | |
|------|----------------------------------|-----------|
| 22 | Abbreviations | 70 |
| 23 | References | 71 |
| 24 | Revision history | 72 |
| 25 | Legal information | 73 |
| 25.1 | Data sheet status | 73 |
| 25.2 | Definitions | 73 |
| 25.3 | Disclaimers | 73 |
| 25.4 | Trademarks | 74 |
| 26 | Contact information | 74 |
| 27 | Tables | 75 |
| 28 | Figures | 76 |
| 29 | Contents | 77 |

Please be aware that important notices concerning this document and the product(s) described herein, have been included in section 'Legal information'.

© NXP Semiconductors N.V. 2015.

All rights reserved.

For more information, please visit: <http://www.nxp.com>

For sales office addresses, please send an email to: salesaddresses@nxp.com

Date of release: 28 April 2015

Document identifier: PCF8523

X-ON Electronics

Largest Supplier of Electrical and Electronic Components

Click to view similar products for [Real Time Clock](#) category:

Click to view products by [NXP](#) manufacturer:

Other Similar products are found below :

[MCP79400T-IMS](#) [DS1302Z-LF](#) [MCP79402-IMS](#) [MCP7940N-IP](#) [710029X](#) [MCP79400T-I/SN](#) [DS1683S+T&R](#) [DS1672U-2](#) [DS1374U-33T&R](#) [DS1372U+T&R](#) [DS1308U-3+](#) [DS1338U-18+T&R](#) [879047C](#) [405800G](#) [DS1341U+T&R](#) [MCP79400T-ISN](#) [PT7C43390WEX](#) [DS1340U-3+T&R](#) [PT7C43390LE](#) [DS1318E+T&R](#) [DS1342T+T&R](#) [PT7C4337ACSE](#) [RX8900SA](#) [UB3 PURE SN](#) [RV-3029-C2-32.768k-OPTION-B-TB-QA](#) [RV-3029-C2-32.768k-OPTION-A-TB-QA](#) [RV-1805-C3-32.768kHz-2PPM-TA-QC](#) [PT7C4337AWEX](#) [RX8130CE B0](#) [PT7C4563UEX](#) [PT7C4311WEX](#) [DS1374C-33#T&R](#) [RV-3029-C3-32.768k-OPTION-A-TB-QA](#) [RV-2123-C2-32.768kHz-20PPM-TA-QC](#) [DS1308U-33+T](#) [DS1339U-3+T&R](#) [DS1339BU+T](#) [RX8900SA UC3 PURE SN](#) [PT7C4307WEX](#) [DS1339AU+T](#) [DS1308U-18+T](#) [RX8804CE XA3](#) [RX8130CE BX](#) [DS1341T+T&R](#) [CBM1307AS8](#) [RTC8563SOF](#) [RX-8025SA](#) [XL1307](#) [DS1338U-3+T&R](#) [MCP79401-I/ST](#) [MCP795W20-IST](#)