

3.3V, Wide Bandwidth, 2-Channel, 2:1 Mux/DeMux USB 2.0 Switch w/ Single Enable

Features

- R_{ON} is 4Ω typical
- Low bit-to-bit skew: 200ps
- Low Crosstalk: -22dB @ 250MHz
- Near-Zero propagation delay: 250ps
- Switching speed: 9ns
- Channel On Capacitance: 6pF (typical)
- V_{CC} Operating Range: +3.0V to +3.6V
- ESD>2000V . . . Human Body Model
- >500 MHz bandwidth (or data frequency)
- Packaging:
 - Pb-free & Green, 12-contact TDFN (ZE)

Description

The PI3USB10 is a 4- to 2-Channel multiplexer/demultiplexer USB 2.0 Switch with Hi-Z outputs. Industry leading advantages include a propagation delay of less than 250ps, resulting from its low channel resistance and I/O capacitance. The device multiplexes differential outputs from a USB Host device to one of two corresponding outputs. The switch is bidirectional and offers little or no attenuation of the high-speed signals at the outputs. It is designed for low bit-to-bit skew, high channel-to-channel noise isolation and is compatible with various standards, such as High Speed USB 2.0 (480 Mb/s).

Application

- Routes signals for USB 2.0

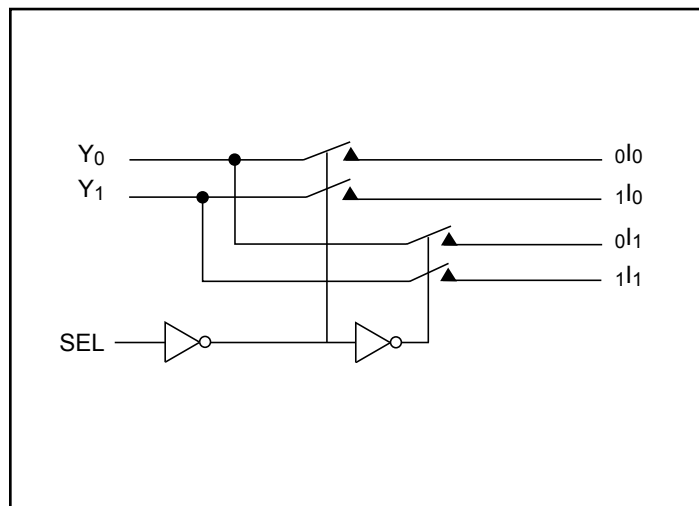
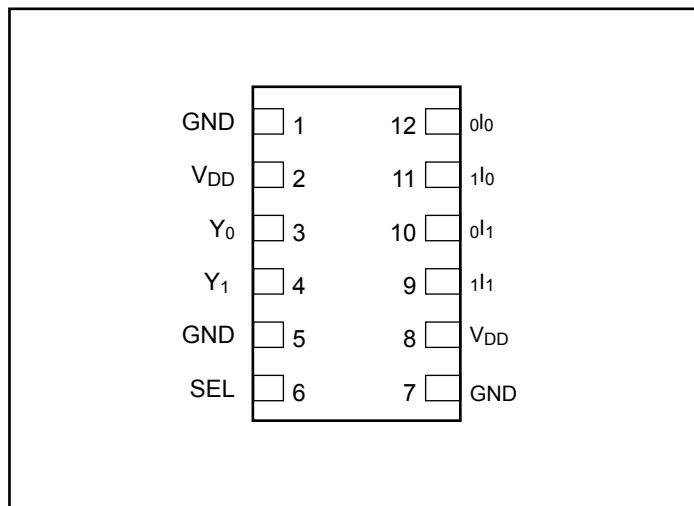
Block Diagram

Pin Description

Truth Table

Function	SEL
Y_n to nI_o	L
Y_n to nI_1	H

Maximum Ratings

(Above which useful life may be impaired. For user guidelines, not tested.)

Storage Temperature	-65°C to +150°C
Supply Voltage to Ground Potential	-0.5V to +4.0V
DC Input Voltage	-0.5V to +5.5V
DC Output Current	120mA
Power Dissipation	0.5W

Note: Stresses greater than those listed under MAXIMUM RATINGS may cause permanent damage to the device. This is a stress rating only and functional operation of the device at these or any other conditions above those indicated in the operational sections of this specification is not implied. Exposure to absolute maximum rating conditions for extended periods may affect reliability.

DC Electrical Characteristics for USB 2.0 Switching over Operating Range

($T_A = -40^\circ\text{C}$ to $+85^\circ\text{C}$, $V_{CC} = 3.3\text{V} \pm 10\%$)

Parameter	Description	Test Conditions		Min.	Typ. ⁽²⁾	Max.	Units
V_{IH}	Input HIGH Voltage	Guaranteed HIGH level	$V_{CC} = 4.2\text{V}$	2.0V			V
			$V_{CC} = 3.3\text{V}$	1.6V			
V_{IL}	Input LOW Voltage	Guaranteed HIGH level				0.8	
V_{IK}	Clamp Diode Voltage	$V_{CC} = \text{Max.}, I_{IN} = -18\text{mA}$			-0.7	-1.2	
I_{IH}	Input HIGH Current	$V_{CC} = \text{Max.}, V_{IN} = V_{CC}$				± 5	μA
I_{IL}	Input LOW Current	$V_{CC} = \text{Max.}, V_{IN} = \text{GND}$				± 5	
R_{ON}	Switch On-Resistance ⁽³⁾	$V_{CC} = \text{Min.}, 1.25\text{V} \leq V_{IN} \leq V_{CC}, I_{IN} = -40\text{mA}$			4	8	Ω
$R_{FLAT(ON)}$	On-Resistance Flatness ⁽⁴⁾	$V_{CC} = \text{Min.}, V_{IN} @ 1.5\text{V}$ and $V_{CC} I_{IN} = -40\text{mA}$			1.0		
ΔR_{ON}	On-Resistance match from center ports to any other port ⁽⁴⁾	$V_{CC} = \text{Min.}, 1.5\text{V} \leq V_{IN} \leq V_{CC}, I_{IN} = -40\text{mA}$			0.9	2	

Capacitance ($T_A = 25^\circ\text{C}$, $f = 1\text{MHz}$)

Parameters ⁽⁴⁾	Description	Test Conditions	Typ.	Max.	Units
C_{IN}	Input Capacitance	$V_{IN} = 0\text{V}$	2.0	3.0	pF
C_{OFF}	Port I Capacitance, Switch OFF		4.0	6.0	
C_{ON}	Switch Capacitance, Switch ON		6.0	10.0	

Notes:

- For max. or min. conditions, use appropriate value specified under Electrical Characteristics for the applicable device type.
- Typical values are at $V_{CC} = 3.3\text{V}$, $T_A = 25^\circ\text{C}$ ambient and maximum loading.
- Measured by the voltage drop between A and B pins at indicated current through the switch. ON-resistance is determined by the lower of the voltages on the two (A & B) pins.
- This parameter is determined by device characterization but is not production tested.

Power Supply Characteristics

Parameters	Description	Test Conditions ⁽¹⁾	Min.	Typ. ⁽²⁾	Max.	Units
I _{CC}	Quiescent Power Supply Current	V _{CC} = Max., V _{IN} = GND or V _{CC}			800	μA

Notes:

1. For max. or min. conditions, use appropriate value specified under Electrical Characteristics for the applicable device type.
2. Typical values are at V_{CC} = 3.3V, T_A = 25°C ambient and maximum loading.
3. Per TTL driven input (control inputs only); A and B pins do not contribute to I_{CC}.

Dynamic Electrical Characteristics Over the Operating Range

(T_A = -40°C to +85°C, V_{CC} = 3.3V ±10%, GND = 0V)

Parameters	Description	Test Conditions	Min.	Typ. ⁽¹⁾	Max.	Units
X _{TALK}	Crosstalk	R _L = 100Ω, f = 250 MHz		-27		dB
O _{IRR}	OFF Isolation			-32		
BW	Bandwidth -3dB	R _L = 100Ω		500		MHz

Switching Characteristics

Parameters	Description	Test Conditions	Min.	Typ. ⁽¹⁾	Max.	Units
t _{PD}	Propagation Delay ^(2,3)		-	0.25		ns
t _{PZH} , t _{PZL}	Line Enable Time - SEL to Y _N , N _{I0} , I _N		0.5	-	15.0	
t _{PHZ} , t _{PLZ}	Line Disable Time - SEL to Y _N , N _{I0} , I _N		0.5	-	9.0	
t _{SK(o)}	Output Skew between center port to any other port ⁽²⁾		-	0.1	0.2	
t _{SK(p)}	Skew between opposite transitions of the same output (t _{PHL} - t _{PLH}) ⁽²⁾		-	0.1	0.2	

Notes:

1. For max. or min. conditions, use appropriate value specified under Electrical Characteristics for the applicable device type.
2. Guaranteed by design.
3. The bus switch contributes no propagational delay other than the RC delay of the On-Resistance of the switch and the load capacitance. The time constant for the switch alone is of the order of 0.25ns for 10pF load. Since this time constant is much smaller than the rise/fall times of typical driving signals, it adds very little propagational delay to the system. Propagational delay of the bus switch when used in a system is determined by the driving circuit on the driving side of the switch and its interactions with the load on the driven side.

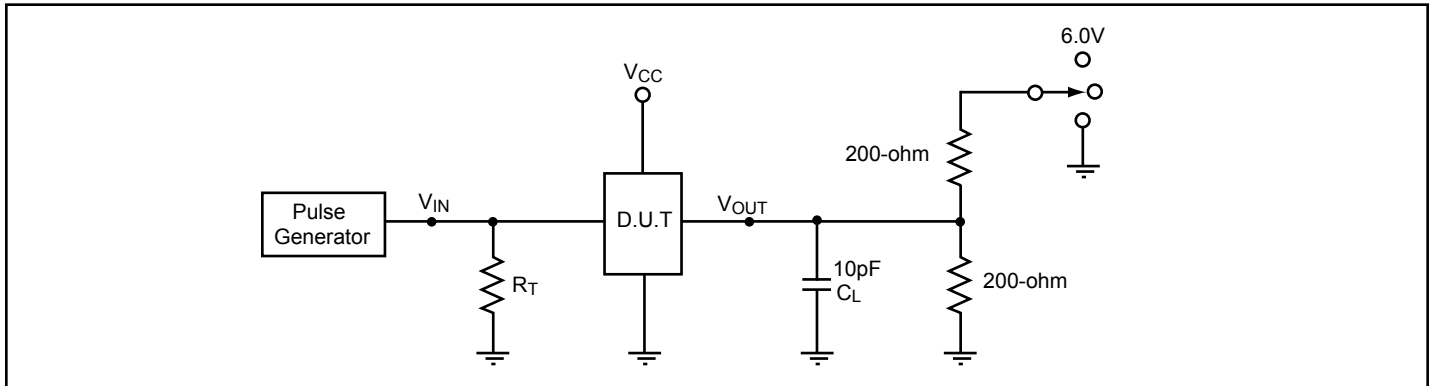
Test Circuit for Electrical Characteristics⁽¹⁾

Notes:

1. C_L = Load capacitance: includes jig and probe capacitance.
2. R_T = Termination resistance: should be equal to Z_{OUT} of the Pulse Generator
3. Waveform 1 is for an output with internal conditions such that the output is low except when disabled by the output control.
Waveform 2 is for an output with internal conditions such that the output is high except when disabled by the output control.
4. All input impulses are supplied by generators having the following characteristics: $PRR \leq \text{MHz}$, $Z_O = 50\Omega$, $t_R \leq 2.5\text{ns}$, $t_F \leq 2.5\text{ns}$.
5. The outputs are measured one at a time with on transition per measurement.

Switch Positions

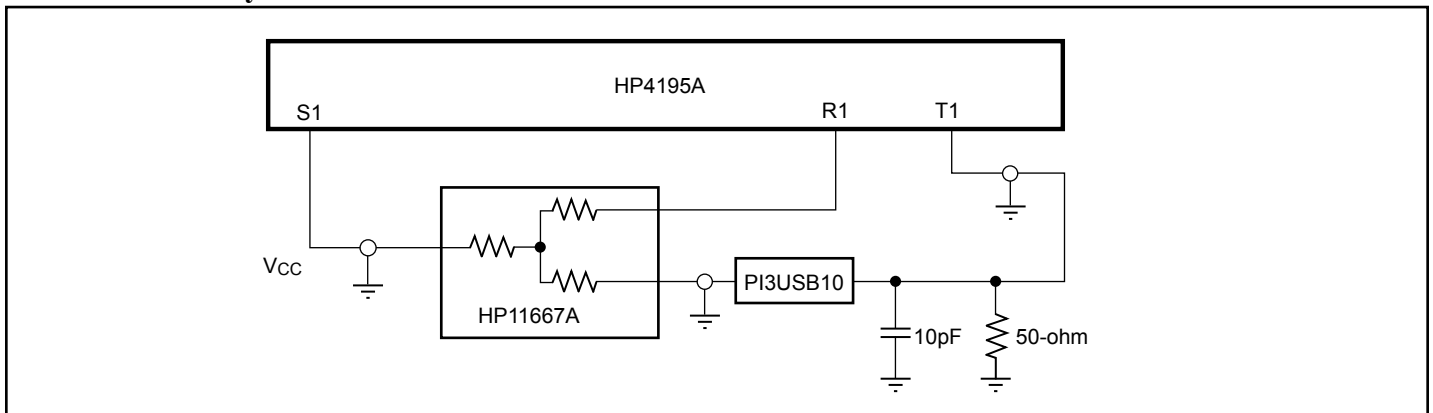
Test	Switch
t_{PLZ} , t_{PZL} (output on I-side)	6.0V
t_{PHZ} , t_{PZH} (output on I-side)	GND
Prop Delay	Open

Test Circuit for Dynamic Electrical Characteristics

Switching Waveforms

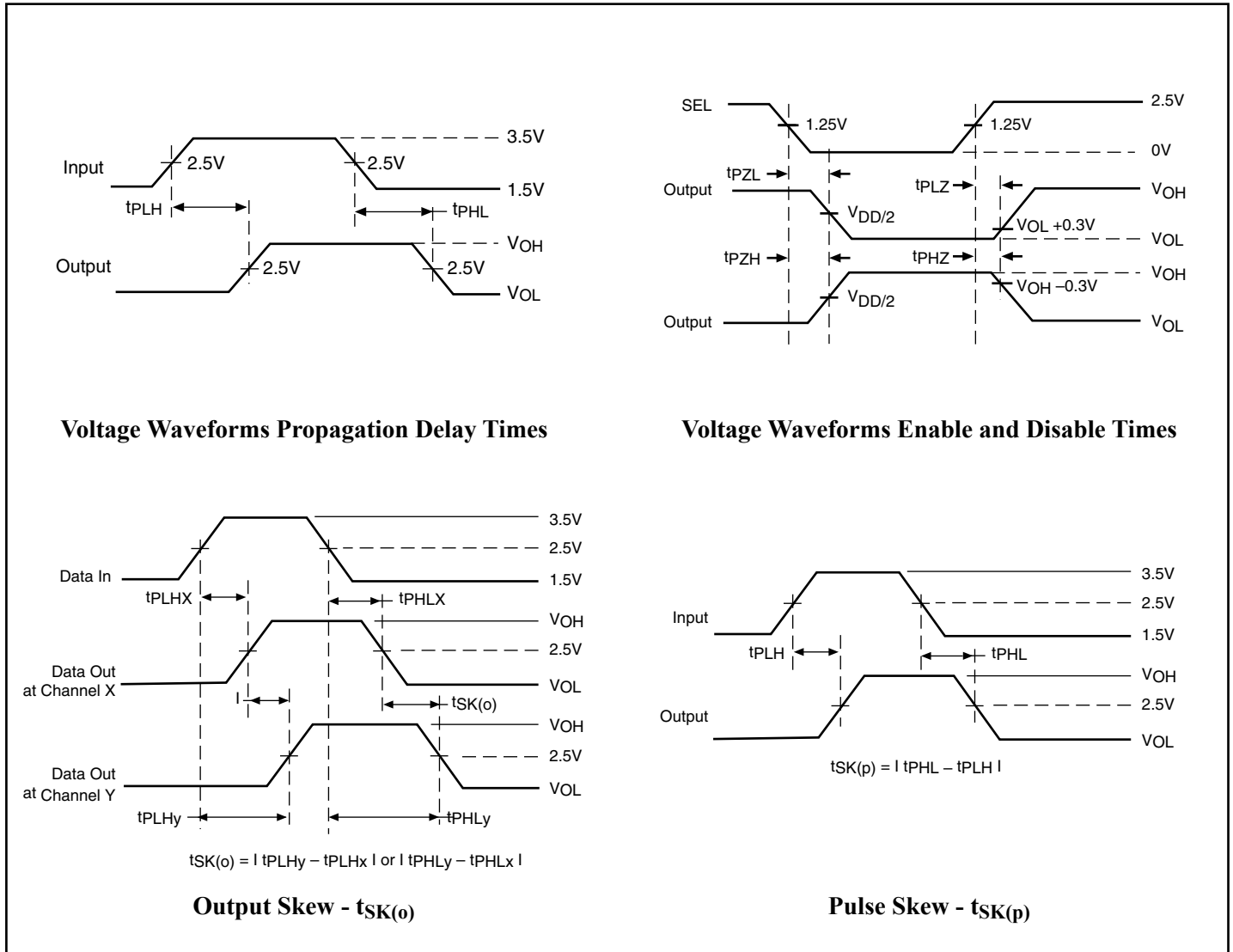

Applications Information

Logic Inputs

The logic control inputs can be driven up to +3.6V regardless of the supply voltage. For example, given a +3.3V supply, the output enables or select pins may be driven low to 0V and high to 3.6V. Driving IN Rail-to-Rail® minimizes power consumption.

Power-Supply Sequencing

Proper power-supply sequencing is advised for all CMOS devices. It is recommended to always apply V_{CC} before applying signals to the input/output or control pins.

Rail-to-Rail is a registered trademark of Nippon Motorola, Ltd

Package Mechanical: 12-Contact TDFN (ZE)

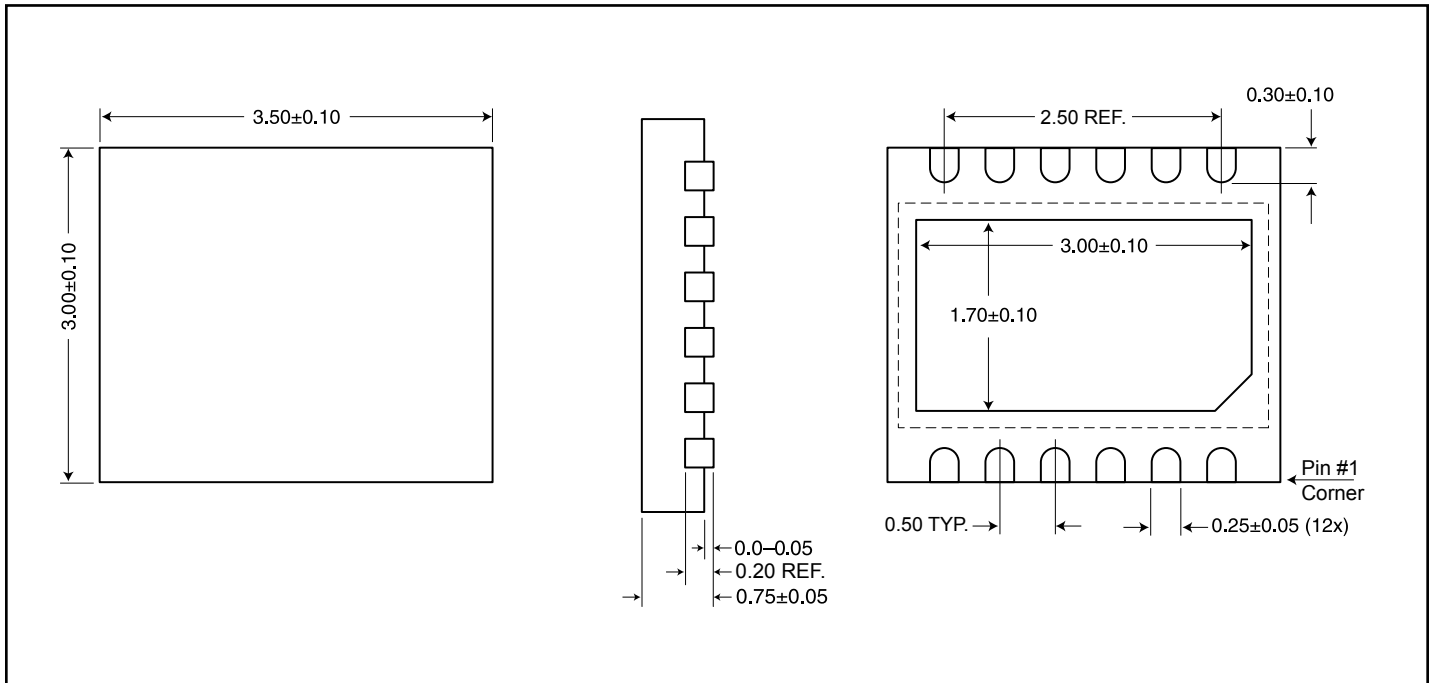

Ordering Information

Ordering Code	Package Code	Package Description	Top Marking
PI3USB10ZEE	ZE	Pb-free & Green, 12-contact TDFN	YJE

Notes:

1. Thermal characteristics can be found on the company web site at www.pericom.com/packaging/

X-ON Electronics

Largest Supplier of Electrical and Electronic Components

Click to view similar products for [Analogue Switch ICs](#) category:

Click to view products by [Diodes Incorporated](#) manufacturer:

Other Similar products are found below :

[FSA3051TMX](#) [NLVAS4599DTT1G](#) [MAX4992EVB+T](#) [MAX4684ETB+T](#) [BCM6522IPBG](#) [BCM65300IFSBG](#) [MAX14764ETA+T](#)
[TMUX1113RSVR](#) [TMUX1112RSVR](#) [ADG1436TRUZ-EP](#) [BL4684C](#) [PE423422A](#) [PE42359SCAA](#) [PE42540F](#) [RS550YUCM12](#)
[ADGS1414DBCCZ](#) [ADG658YRUZ-REEL7](#) [RS2117YUTQK10](#) [RS2118YUTQK10](#) [RS2227XUTQK10](#) [SP2526A-1EN-L/TR](#) [FSA4157P6X](#)
[BA7603F-E2](#) [MAX4702EUE+](#) [MAX4617CUE+](#) [MAX4599EUT+T](#) [MAX4066ESD+](#) [MAX4052ACSE+](#) [MAX396CAI+](#) [MAX391CPE+](#)
[MAX4730EXT+T](#) [MAX314CPE+](#) [MAX4051AEEE+](#) [BU4066BCFV-E2](#) [MAX313CPE+](#) [BU4S66G2-TR](#) [TS3A4751PWR](#)
[NCN1154MUTAG](#) [DG444DY-E3](#) [NLAS4157DFT2G](#) [NLAS4599DFT2G](#) [NLAS7242MUTBG](#) [NLASB3157DFT2G](#) [NLAST4599DFT2G](#)
[NLAST4599DTT1G](#) [DG403DY-T1-E3](#) [MAX4714EXTT](#) [MAX392CPE](#) [BGSX22G2A10E6327XTSA1](#) [ADG1611BRUZ-REEL7](#)