

1. C REPRESENTS A CRITICAL DIMENSION.
2. MINIMUM CONTACT RETENTION: 12 OZS.
3. MINIMUM LOCKING CLIP RETENTION: 8 OZS.
4. MAXIMUM HEIGHT VARIATION BETWEEN ANY TWO PINS: .005[0.13].
5. MAXIMUM TERMINAL BURR: .003[0.08].
6. COPLANARITY: .004[0.10] = POS 02 THRU 26
.006[0.15] = POS 27 THRU 50.
7. MEASURED FROM BEND.
8. MEASURE FROM TIPS OF PIN.
9. SIDES OF PLASTIC BODIES ON ALL LEAD STYLES EXCEPT THE -01 & -02 WILL BE SOLID AND WITHOUT SIDE SLOTS.
10. THIS FEATURE ONLY PRESENT ON -01 & -02 LEAD STYLES.
11. DUE TO THE HIGH AMOUNT OF INSERTION FORCE NEEDED, THE -LC OPTION IS NOT COMPATIBLE WITH AUTO PLACEMENT. SAMTEC RECOMMENDS MANUAL PLACEMENT FOR ALL ASSEMBLIES WITH THE -LC OPTION.
12. NOTE DELETED.

No OF POSITIONS

- LEAD STYLE -01, -02: -02 THRU -50 (ALL POSITIONS AVAILABLE)
 LEAD STYLES -11, -12: (-05 THRU -50 MULTIPLES OF 5) POSITIONS -12, -16, -17 ALSO AVAILABLE
 LEAD STYLES -21, -22: (-05 THRU -50 MULTIPLES OF 5) POSITIONS -12 & -13 ALSO AVAILABLE
 LEAD STYLES -31, -32: (-05 THRU -50 MULTIPLES OF 5) -12 POSITION ALSO AVAILABLE

LEAD STYLE

THROUGH HOLE	SURFACE MOUNT
-01 (SEE FIG 1)	-02 (SEE FIG 2, SHT 2)
-11 (SEE FIG 1)	-12 (SEE FIG 2, SHT 2)
-21 (SEE FIG 1)	-22 (SEE FIG 2, SHT 2)
-31 (SEE FIG 1)	-32 (SEE FIG 2, SHT 2)

(SEE TABLE 1, SHT 3)

PLATING SPECIFICATION

- F: 3 μ " FLASH GOLD ON CONTACT AREA, MATTE TIN TAIL
- L: 15 μ " SELECTIVE GOLD ON CONTACT AREA, MATTE TIN TAIL
- LM: 15 μ " SELECTIVE GOLD ON CONTACT AREA, MATTE TIN TAIL
- FM: 3 μ " FLASH GOLD ON CONTACT AREA, MATTE TIN TAIL

OPTION

- A: ALIGNMENT PIN (USE TFM-XX-D-XX-A, SEE TABLE 1, SHT 3) (SEE FIG 5, SHT 3) (NOT AVAILABLE WITH -RA)
- LC: LOCKING CLIP (USE LC-05-TM) (NOT AVAILABLE WITH -RA) (SEE FIG 6, SHT 3, NOTE 3 & 11)
- P: PICK AND PLACE PAD (USE PPP-04) (AVAILABLE IN ALL POSITIONS -05 THRU -50) (NOT AVAILABLE WITH -RA) (SEE FIG 7, SHT 3)
- RA: RIGHT ANGLE (AVAILABLE ONLY IN LEAD STYLE: -01) (SEE FIG 8, SHT 2)
- TR: TAPE AND REEL (SEE FIG 4, SHT 4) (FOR -X2 ONLY) (NOT AVAILABLE WITH -RA)
- K: POLYIMIDE FILM (SEE FIG 3, SHT 2) (ALL LEAD STYLES EXCEPT -21 AVAILABLE) (NOT AVAILABLE FOR -RA) (USE K-DOT-.217-.313-.005)

BODY SPECIFICATION

- D: DOUBLE ROW

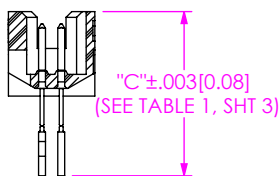
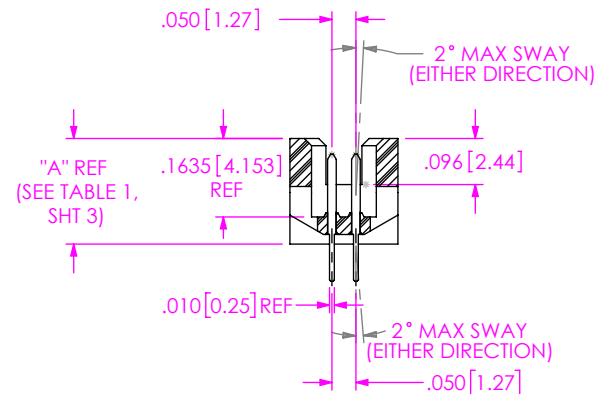
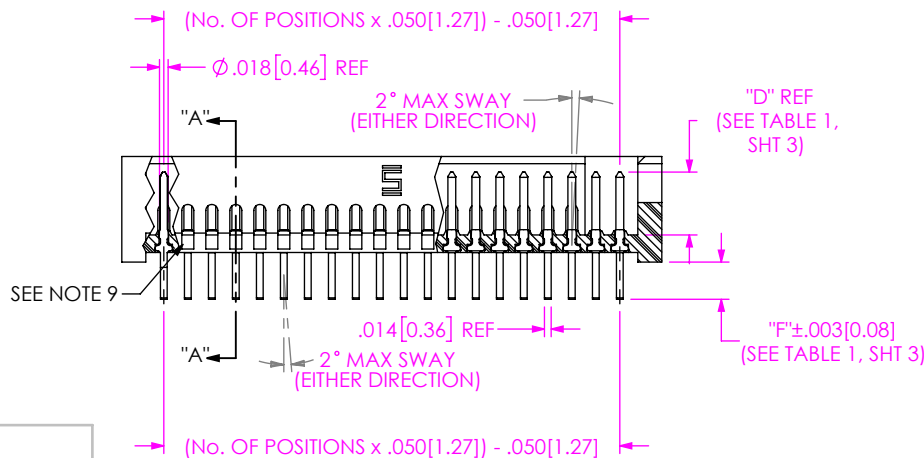
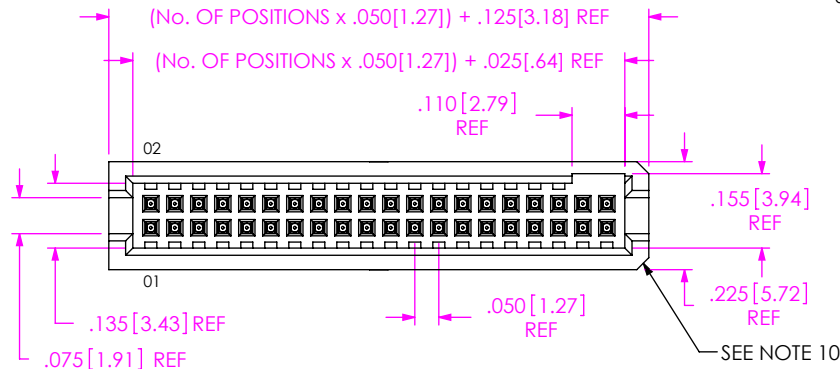

IN-PROCESS

FIG 1 THROUGH HOLE -01, -11, -21, -31

UNLESS OTHERWISE SPECIFIED, DIMENSIONS ARE IN INCHES.
 TOLERANCES ARE:
 DECIMALS ANGLES
 .XX: ± 0.01 [.] 2°
 .XXX: ± 0.005 [.13]
 .XXXX: ± 0.0020 [.051]

PROPRIETARY NOTE
 THIS DOCUMENT CONTAINS CONFIDENTIAL AND PROPRIETARY INFORMATION AND ALL DESIGN, MANUFACTURING, REPRODUCTION, USE, PATENT RIGHTS AND SALES RIGHTS ARE EXPRESSLY RESERVED BY SAMTEC, INC. THIS DOCUMENT SHALL NOT BE DISCLOSED, IN WHOLE OR PART, TO ANY UNAUTHORIZED PERSON OR ENTITY NOR REPRODUCED, TRANSFERRED OR INCORPORATED IN ANY OTHER PROJECT IN ANY MANNER WITHOUT THE EXPRESS WRITTEN CONSENT OF SAMTEC, INC.



520 PARK EAST BLVD, NEW ALBANY, IN 47150
 PHONE: 812-944-6733 FAX: 812-948-5047
 e-Mail info@SAMTEC.com code 55322

MATERIAL: DO NOT SCALE DRAWING SHEET SCALE: 2.5:1
 INSULATOR: LCP, UL 94-V0
 COLOR: BLACK

TERMINAL: PHOSPHOR BRONZE
 F:\DWG\MISC\MKTG\TFC-1XX-XX-XX-D-XX-MKT.SLDDRW

DESCRIPTION: .050 X .050 TERMINAL STRIP

DWG. NO. TFC-1XX-XX-XX-D-XX

BY: BRATCHER 05/25/2001 SHEET 1 OF 4

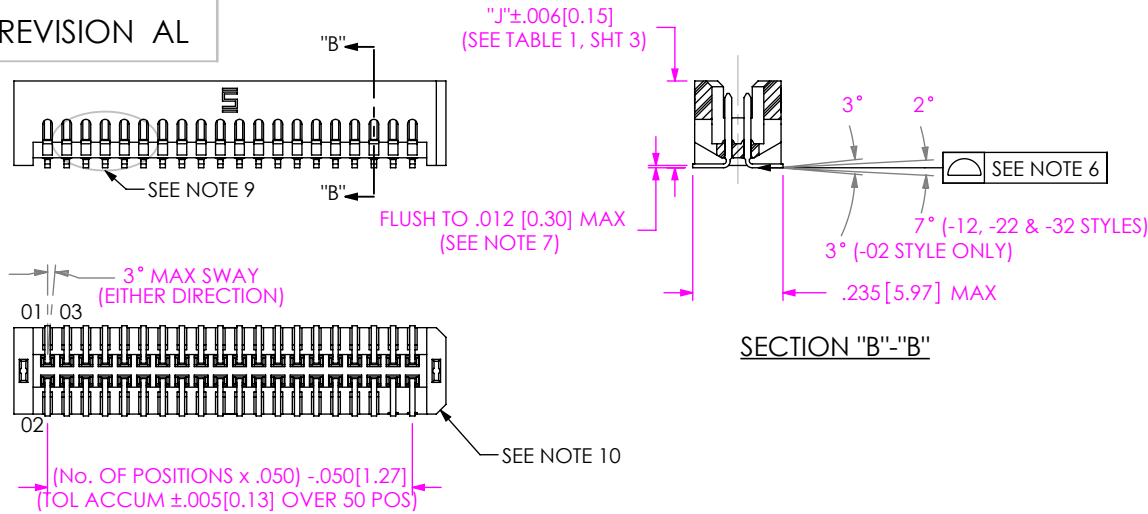

FIG 2
SURFACE MOUNT
-02, -12, -22, -32
DIFFERENT AS SHOWN, OTHERWISE SAME AS FIG 1

NOTE: "R" = OVERALL LENGTH (REF)
"S" = $\{("R" - .216[5.49]) / 2\} \pm .020[.51]$

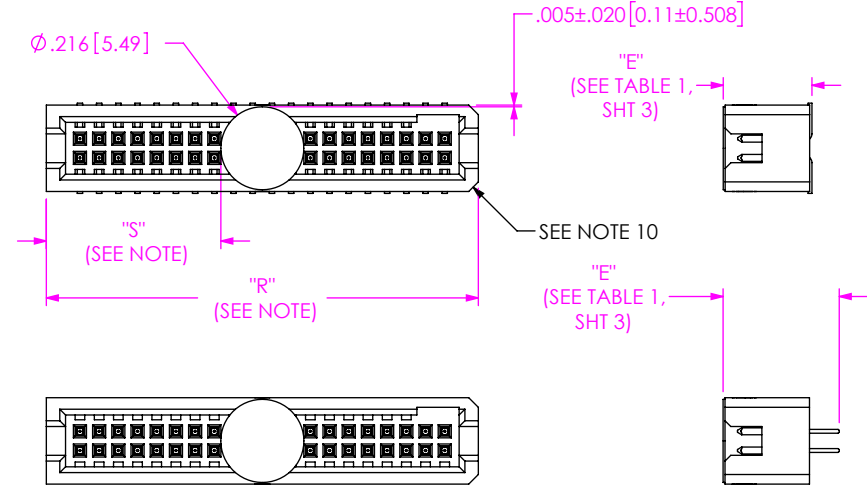

FIG 3
-K: POLYIMIDE FILM PAD

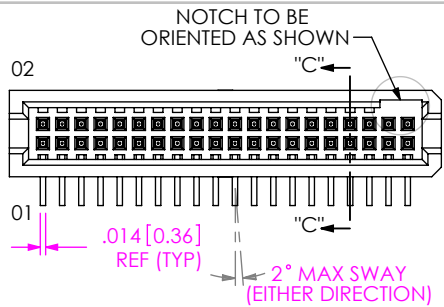
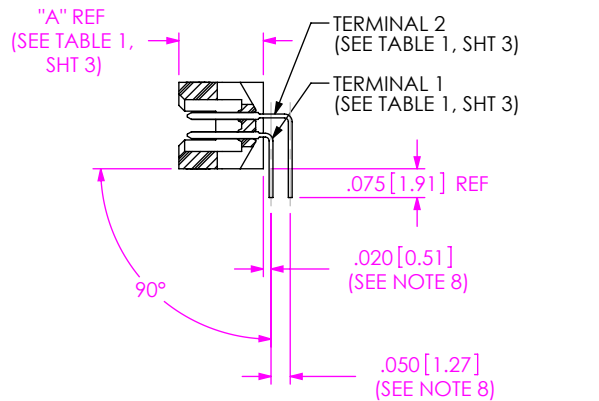
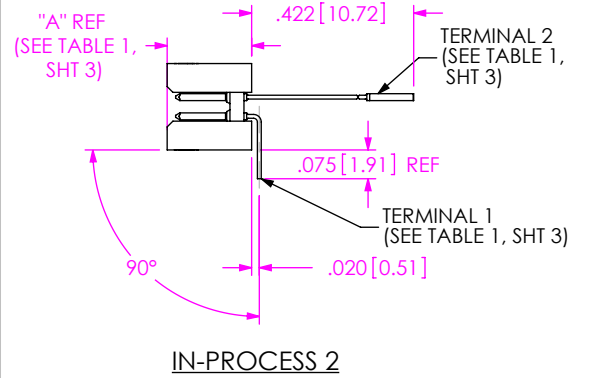
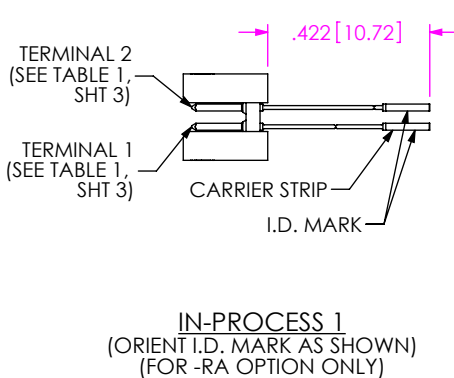

FIG 8
-RA OPTION
DIFFERENT AS SHOWN, OTHERWISE SAME AS FIG 1



SECTION "C"-"C"



IN-PROCESS 2

F:\DWG\MISC\MKTG\TFC-1XX-XX-XX-D-XX-MKT.SLDDRW

PROPRIETARY NOTE
THIS DOCUMENT CONTAINS CONFIDENTIAL AND PROPRIETARY INFORMATION AND ALL DESIGN, MANUFACTURING, REPRODUCTION, USE, PATENT RIGHTS AND SALES RIGHTS ARE EXPRESSLY RESERVED BY SAMTEC, INC. THIS DOCUMENT SHALL NOT BE DISCLOSED, IN WHOLE OR PART, TO ANY UNAUTHORIZED PERSON OR ENTITY NOR REPRODUCED, TRANSFERRED OR INCORPORATED IN ANY OTHER PROJECT IN ANY MANNER WITHOUT THE EXPRESS WRITTEN CONSENT OF SAMTEC, INC.

DO NOT SCALE DRAWING

SHEET SCALE: 2:1

samtec

520 PARK EAST BLVD, NEW ALBANY, IN 47150
PHONE: 812-944-6733 FAX: 812-948-5047
e-Mail info@SAMTEC.com code 55322

DESCRIPTION:
.050 X .050 TERMINAL STRIP

DWG. NO.
TFC-1XX-XX-XX-D-XX

BY: BRATCHER 05/25/2001 SHEET 2 OF 4

TABLE 1									
LEAD STYLE	BODY	"A"	TERMINAL 1	TERMINAL 2	"C"	"D"	"E"	"F"	"J"
-01	TFM-XX-D-01-XX	.2200 [5.588]	T-1R16-01-XX-2	N/A	.428 [10.87]	.131 [3.33]	.303 [7.70]	.078 [1.98]	N/A
-11	TFM-XX-D-02-XX	.2900 [7.366]	T-1R20-03-XX	N/A	.645 [16.38]	.139 [3.53]	.375 [9.53]	.080 [2.03]	N/A
-21	TFM-XX-D-03-XX	.3600 [9.144]	T-1R20-04-XX	N/A	.645 [16.38]	.139 [3.53]	N/A	.080 [2.03]	N/A
-31	TFM-XX-D-04-XX	.4350 [11.049]	T-1R20-02-XX	N/A	.645 [16.38]	.139 [3.53]	.520 [13.21]	.080 [2.03]	N/A
-02	TFM-XX-D-01-XX	.2200 [5.588]	T-1R16-01-XX-2	N/A	.428 [10.87]	.131 [3.33]	.231 [5.87]	N/A	.226 [5.74]
-12	TFM-XX-D-02-XX	.2900 [7.366]	T-1R20-03-XX	N/A	.645 [16.38]	.139 [3.53]	.301 [7.65]	N/A	.296 [7.52]
-22	TFM-XX-D-03-XX	.3600 [9.144]	T-1R20-04-XX	N/A	.645 [16.38]	.139 [3.53]	.371 [9.42]	N/A	.366 [9.30]
-32	TFM-XX-D-04-XX	.4350 [11.049]	T-1R20-02-XX	N/A	.645 [16.38]	.139 [3.53]	.446 [11.33]	N/A	.441 [11.20]
-01-RA	TFM-XX-D-01-XX	.2200 [5.588]	T-1R16-02-XX	T-1R16-03-XX	N/A	.142 [3.61]	N/A	N/A	N/A

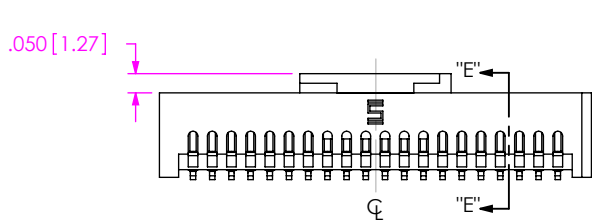
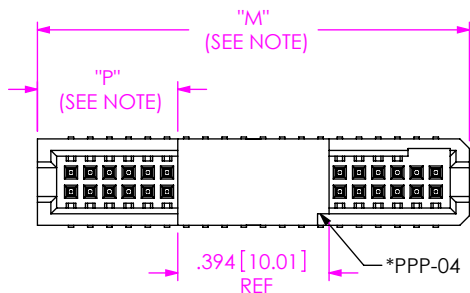

NOTE: "M" = (No. OF POS X .050[1.27]) + .125[3.18] (REF)
 "P" = {"M" - .394[10.01]} / 2 ± .020[.51]

* NOTCH ON PAD TO BE ON SAME END AS THE NOTCH IN THE TFM BODY

FIG 7
 -P OPTION
 DIFFERENT AS SHOWN, OTHERWISE SAME AS FIG 1
 (PAD TO BE POSITIONED ON CL AS SHOWN)

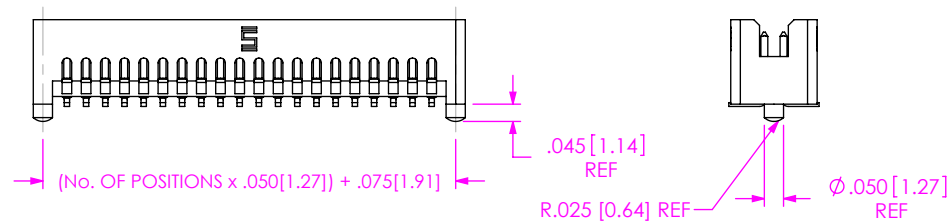
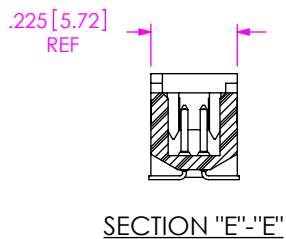

FIG 5
 -A OPTION
 DIFFERENT AS SHOWN, OTHERWISE SAME AS FIG 1

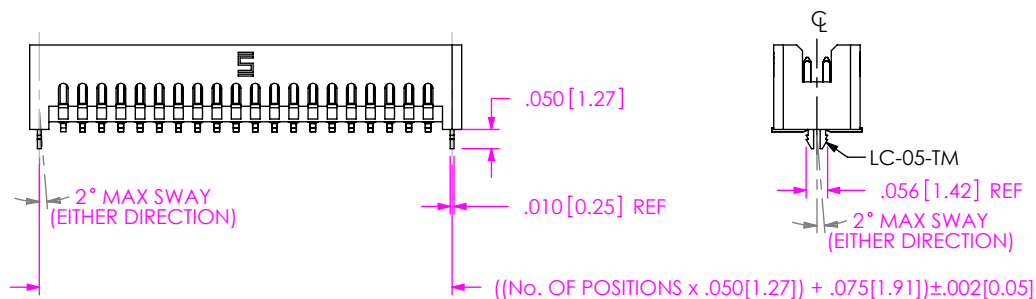

FIG 6
 -LC OPTION
 DIFFERENT AS SHOWN, OTHERWISE SAME AS FIG 1
 (NOT AVAILABLE ON -RA)

F:\DWG\MISC\MKTG\TFC-1XX-XX-XX-D-XX-MKT.SLDDRW

PROPRIETARY NOTE
 THIS DOCUMENT CONTAINS CONFIDENTIAL AND PROPRIETARY INFORMATION AND ALL DESIGN, MANUFACTURING, REPRODUCTION, USE, PATENT RIGHTS AND SALES RIGHTS ARE EXPRESSLY RESERVED BY SAMTEC, INC. THIS DOCUMENT SHALL NOT BE DISCLOSED, IN WHOLE OR PART, TO ANY UNAUTHORIZED PERSON OR ENTITY NOR REPRODUCED, TRANSFERRED OR INCORPORATED IN ANY OTHER PROJECT IN ANY MANNER WITHOUT THE EXPRESS WRITTEN CONSENT OF SAMTEC, INC.
 DO NOT SCALE DRAWING
 SHEET SCALE: 2:1

samtec
 520 PARK EAST BLVD, NEW ALBANY, IN 47150
 PHONE: 812-944-6733 FAX: 812-948-5047
 e-Mail info@SAMTEC.com code 55322

DESCRIPTION:
 .050 X .050 TERMINAL STRIP

DWG. NO.
TFC-1XX-XX-XX-D-XX

BY: BRATCHER 05/25/2001 SHEET 3 OF 4

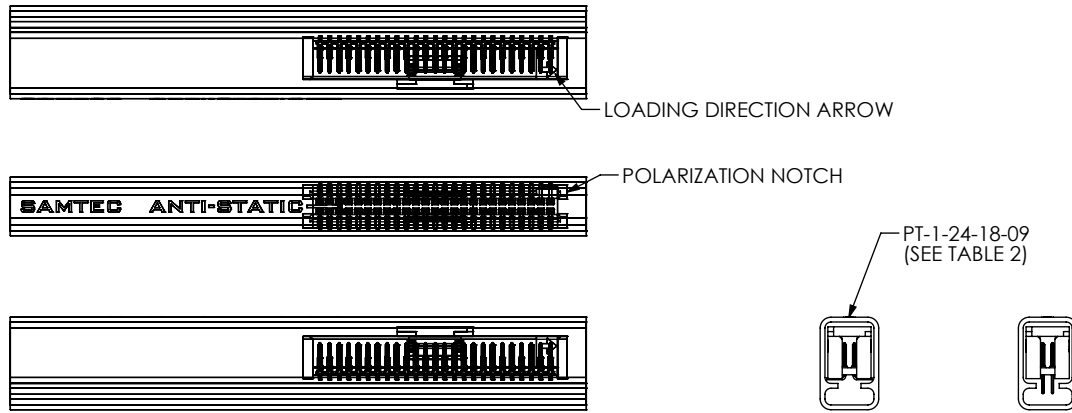

FIG 9
PT-1-24-XX-09

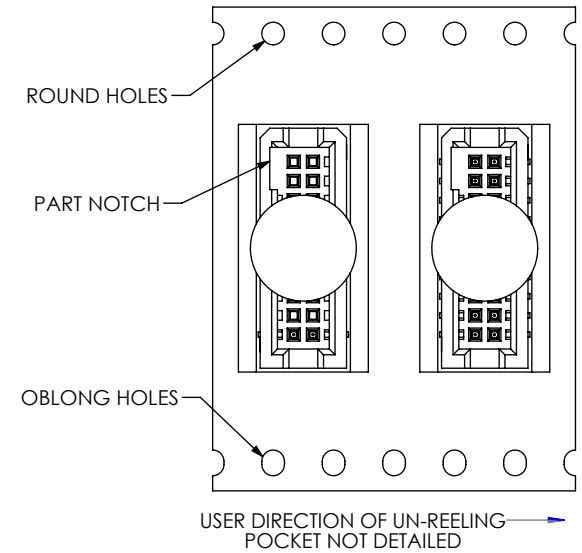

FIG 4
-TR: TAPE AND REEL

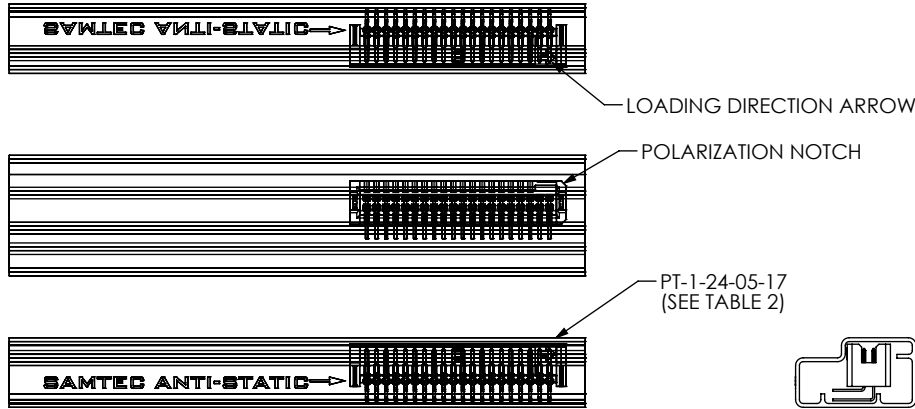

FIG 10
PT-1-24-05-17

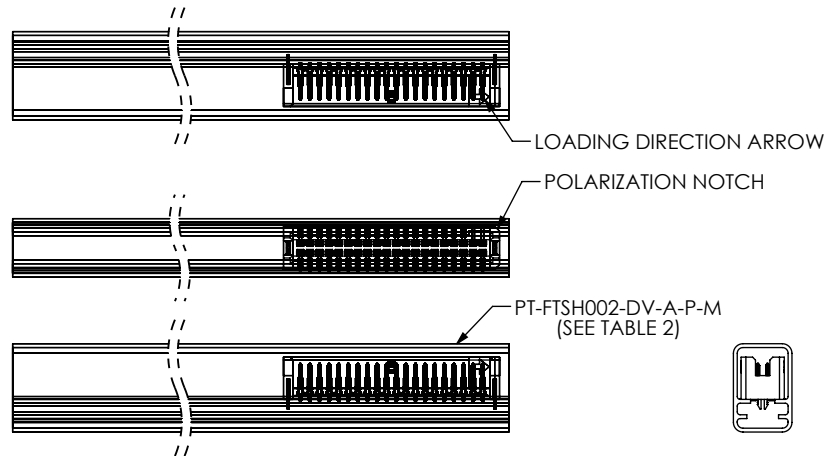

FIG 11
PT-FTSH002-DV-A-P-M

TABLE 2			
LEAD STYLE	OPTION	TUBE	PLUG
-01	-K, -LC-K, -LC-P, -A-P, -A-K, -P, -WT-P	PT-1-24-18-09	TP-09
	BLANK, -A, -LC, -WT	PT-FTSH002-DV-A-P-M	TP-03
-01-RA	ANY	PT-1-24-5-17	TP-07
-11	BLANK, -A, -A-K, -LC, -LC-K, -K	PT-1-24-18-09	TP-09
	-A-P, -LC-P, -P	PT-1-24-20-09	TP-07
-21	BLANK, -A-P, -LC-P, -P	PT-1-24-05-09	TP-07
	-A, -A-K, -LC, -LC-K, -K	PT-1-24-20-09	TP-07
-31	BLANK, -A, -LC	PT-1-24-05-09	TP-07
	-A-K, -LC-K, -K, -A-P, -LC-P, -P	PT-1-24-02-09	TP-07
-02	BLANK, -A, -A-K, -LC	PT-FTSH002-DV-A-P-M	TP-03
	-LC-K, -K, -A-P, -LC-P, -P	PT-1-24-18-09	TP-09
-12	ANY	PT-1-24-04-09	TP-07
-22	BLANK, -A, -A-K, -LC, -LC-K, -K	PT-1-24-04-09	TP-07
	-A-P, -LC-P, -P	PT-1-24-05-09	TP-07
-32	ANY	PT-1-24-02-09	TP-07

NOTE:
PARTS TO BE PACKAGED WITH THE LOADING DIRECTION ARROW POINTED IN SAME DIRECTION AS THE ARROW ON TUBE.

F:\DWG\MISC\MKTG\TFC-1XX-XX-XX-D-XX-MKT.SLDDRW

PROPRIETARY NOTE
THIS DOCUMENT CONTAINS CONFIDENTIAL AND PROPRIETARY INFORMATION AND ALL DESIGN, MANUFACTURING, REPRODUCTION, USE, PATENT RIGHTS AND SALES RIGHTS ARE EXPRESSLY RESERVED BY SAMTEC, INC. THIS DOCUMENT SHALL NOT BE DISCLOSED, IN WHOLE OR PART, TO ANY UNAUTHORIZED PERSON OR ENTITY NOR REPRODUCED, TRANSFERRED OR INCORPORATED IN ANY OTHER PROJECT IN ANY MANNER WITHOUT THE EXPRESS WRITTEN CONSENT OF SAMTEC, INC.

DO NOT SCALE DRAWING

SHEET SCALE: 2:1

samtec

520 PARK EAST BLVD. NEW ALBANY, IN 47150
PHONE: 812-944-6733 FAX: 812-948-5047
e-Mail info@SAMTEC.com code 53322

DESCRIPTION:
.050 X .050 TERMINAL STRIP

DWG. NO. TFC-1XX-XX-XX-D-XX

BY: BRATCHER 05/25/2001 SHEET 4 OF 4

X-ON Electronics

Largest Supplier of Electrical and Electronic Components

Click to view similar products for [Headers & Wire Housings](#) category:

Click to view products by [Samtec](#) manufacturer:

Other Similar products are found below :

[95000-104TRLF](#) [10135584-644402LF](#) [DF62W-EP2022PCA](#) [95000-106TRLF](#) [DF62W-2022SCA](#) [48050-002LF](#) [DF62W-EP2022PC](#) [2203348](#)
[DF62W-2022SC](#) [1084018](#) [1029039](#) [1084017](#) [802-10-012-10-002000](#) [1112640](#) [1112639](#) [000-34000](#) [0008550134](#) [0009482033](#) [0009507031](#)
[0009524054](#) [57102-F02-18ULF](#) [57102-S06-03LF](#) [57202-S52-04LF](#) [PCN6-15S-2.5E](#) [0039019024](#) [58102-G61-06LF](#) [582553-1](#) [0009485154](#)
[0009508121](#) [0022285053](#) [0050291907](#) [018731A](#) [LY20-4P-DT1-P1E-BR](#) [02.125.8002.8](#) [60101931](#) [60598-1 \(Cut Strip\)](#) [M1625-3R/100](#) [61062-3](#)
[61082-181009](#) [636-1427](#) [638009-1](#) [641938-9](#) [641991-4](#) [644168-1](#) [644827-2](#) [647662-1](#) [65039-019ELF](#) [65692-001LF](#) [65781-018](#) [65781-047](#)