

## 32-bit ARM™ Cortex™-M3 based Microcontroller

# FM3 MB9B110R Series

**MB9BF112N/R, MB9BF114N/R,  
MB9BF115N/R, MB9BF116N/R**

### ■ DESCRIPTION

The MB9B110R Series are a highly integrated 32-bit microcontrollers dedicated for embedded controllers with high-performance and competitive cost.

These series are based on the ARM Cortex-M3 Processor with on-chip Flash memory and SRAM, and has peripheral functions such as Motor Control Timers, ADCs and Communication Interfaces ( UART, CSIO, I<sup>2</sup>C, LIN).

The products which are described in this data sheet are placed into TYPE4 product categories in "FM3 MB9Axxx/MB9Bxxx Series PERIPHERAL MANUAL".

Note: ARM and Cortex are the trademarks of ARM Limited in the EU and other countries.

**ARM™**

Copyright©2012 FUJITSU SEMICONDUCTOR LIMITED All rights reserved  
2012.1

**FUJITSU**

**■ FEATURES**

- 32-bit ARM Cortex-M3 Core
  - Processor version: r2p1
  - Up to 144MHz Frequency Operation
  - Memory Protection Unit (MPU): improves the reliability of an embedded system
  - Integrated Nested Vectored Interrupt Controller (NVIC): 1 NMI (non-maskable interrupt) and 48 peripheral interrupts and 16 priority levels
  - 24-bit System timer (Sys Tick): System timer for OS task management

- On-chip Memories

**[Flash memory]**

These series are based on two independent on-chip Flash memories.

- MainFlash
  - Up to 512Kbyte
  - Built-in Flash Accelerator System with 16Kbyte trace buffer memory
  - The read access to Flash memory can be achieved without wait cycle up to operation frequency of 72MHz. Even at the operation frequency more than 72MHz, an equivalent access to Flash memory can be obtained by Flash Accelerator System.
  - Security function for code protection
- WorkFlash
  - 32Kbyte
  - Read cycle
    - 4wait-cycle: the operation frequency more than 72MHz
    - 2wait-cycle: the operation frequency more than 40MHz, and to 72MHz
    - 0wait-cycle: the operation frequency to 40MHz
  - Security function is shared with code protection

**[SRAM]**

This Series contain a total of up to 64Kbyte on-chip SRAM memories. This is composed of two independent SRAM (SRAM0, SRAM1). SRAM0 is connected to I-code bus or D-code bus of Cortex-M3 core. SRAM1 is connected to System bus.

- SRAM0: Up to 32 Kbyte
- SRAM1: Up to 32 Kbyte

- External Bus Interface

- Supports SRAM, NOR and NAND Flash device
- Up to 8 chip selects
- 8/16-bit Data width
- Up to 25-bit Address bit
- Supports Address/Data multiplex
- Supports external RDY input

- Multi-function Serial Interface (Max 8channels)

- 4 channels with 16-byte FIFO (ch.4-ch.7), 4 channels without FIFO (ch.0-ch.3)
- Operation mode is selectable from the followings for each channel.
  - UART
  - CSIO
  - LIN
  - I<sup>2</sup>C

[UART]

- Full-duplex double buffer
- Selection with or without parity supported
- Built-in dedicated baud rate generator
- External clock available as a serial clock
- Hardware Flow control : Automatically control the transmission by CTS/RTS (only ch.4)
- Various error detect functions available (parity errors, framing errors, and overrun errors)

[CSIO]

- Full-duplex double buffer
- Built-in dedicated baud rate generator
- Overrun error detect function available

[LIN]

- LIN protocol Rev.2.1 supported
- Full-duplex double buffer
- Master/Slave mode supported
- LIN break field generate (can be changed 13 to 16-bit length)
- LIN break delimiter generate (can be changed 1 to 4-bit length)
- Various error detect functions available (parity errors, framing errors, and overrun errors)

[I<sup>2</sup>C]

Standard mode (Max 100kbps) / High-speed mode (Max 400kbps) supported

- DMA Controller (8channels)

DMA Controller has an independent bus for CPU, so CPU and DMA Controller can process simultaneously.

- 8 independently configured and operated channels
- Transfer can be started by software or request from the built-in peripherals
- Transfer address area: 32bit (4Gbyte)
- Transfer mode: Block transfer/Burst transfer/Demand transfer
- Transfer data type: byte/half-word/word
- Transfer block count: 1 to 16
- Number of transfers: 1 to 65536

- A/D Converter (Max 16channels)

[12-bit A/D Converter]

- Successive Approximation Register type
- Built-in 3unit
- Conversion time: 1.0μs@5V
- Priority conversion available (priority at 2levels)
- Scanning conversion mode
- Built-in FIFO for conversion data storage (for SCAN conversion: 16steps, for Priority conversion: 4steps)

- Base Timer (Max 8channels)

Operation mode is selectable from the followings for each channel.

- 16-bit PWM timer
- 16-bit PPG timer
- 16/32-bit reload timer
- 16/32-bit PWC timer

- **General Purpose I/O Port**

This series can use its pins as general purpose I/O ports when they are not used for external bus or peripherals. Moreover, the port relocate function is built in. It can set which I/O port the peripheral function can be allocated.

- Capable of pull-up control per pin
  - Capable of reading pin level directly
  - Built-in the port relocate function
  - Up 103 fast general purpose I/O Ports@120pin Package
  - Some pin is 5V tolerant I/O.
- See "■PIN DESCRIPTION" to confirm the corresponding pins.

- **Multi-function Timer (Max 3units)**

The Multi-function timer is composed of the following blocks.

- 16-bit free-run timer × 3ch./unit
- Input capture × 4ch./unit
- Output compare × 6ch./unit
- A/D activating compare × 3ch./unit
- Waveform generator × 3ch./unit
- 16-bit PPG timer × 3ch./unit

The following function can be used to achieve the motor control.

- PWM signal output function
- DC chopper waveform output function
- Dead time function
- Input capture function
- A/D convertor activate function
- DTIF (Motor emergency stop) interrupt function

- **Real-time clock (RTC)**

The Real-time clock can count Year/Month/Day/Hour/Minute/Second/A day of the week from 01 to 99.

- Interrupt function with specifying date and time (Year/Month/Day/Hour/Minute/Second/A day of the week.) is available. This function is also available by specifying only Year, Month, Day, Hour or Minute.
- Timer interrupt function after set time or each set time.
- Capable of rewriting the time with continuing the time count.
- Leap year automatic count is available.

- **Quadrature Position/Revolution Counter (QPRC) (Max 3channels)**

The Quadrature Position/Revolution Counter (QPRC) is used to measure the position of the position encoder. Moreover, it is possible to use up/down counter.

- The detection edge of the three external event input pins AIN, BIN and ZIN is configurable.
- 16-bit position counter
- 16-bit revolution counter
- Two 16-bit compare registers

- **Dual Timer (32/16-bit Down Counter)**

The Dual Timer consists of two programmable 32/16-bit down counters. Operation mode is selectable from the followings for each channel.

- Free-running
- Periodic (=Reload)
- One-shot

- Watch Counter

The Watch counter is used for wake up from power saving mode.

Interval timer: up to 64s (Max) @ Sub Clock : 32.768kHz

- External Interrupt Controller Unit

- Up to 32 external interrupt input pin
- Include one non-maskable interrupt (NMI)

- Watchdog Timer (2channels)

A watchdog timer can generate interrupts or a reset when a time-out value is reached.

This series consists of two different watchdogs, a "Hardware" watchdog and a "Software" watchdog.

"Hardware" watchdog timer is clocked by low-speed internal CR oscillator. Therefore, "Hardware" watchdog is active in any power saving mode except STOP.

- CRC (Cyclic Redundancy Check) Accelerator

The CRC accelerator helps a verify data transmission or storage integrity.

CCITT CRC16 and IEEE-802.3 CRC32 are supported.

- CCITT CRC16 Generator Polynomial: 0x1021
- IEEE-802.3 CRC32 Generator Polynomial: 0x04C11DB7

- Clock and Reset

[Clocks]

Five clock sources (2 external oscillators, 2 internal CR oscillator, and Main PLL) that are dynamically selectable.

- Main Clock : 4MHz to 48MHz
- Sub Clock : 32.768kHz
- High-speed internal CR Clock : 4MHz
- Low-speed internal CR Clock : 100kHz
- Main PLL Clock

[Resets]

- Reset requests from INITX pin
- Power on reset
- Software reset
- Watchdog timers reset
- Low-voltage detector reset
- Clock supervisor reset

- Clock Super Visor (CSV)

Clocks generated by internal CR oscillators are used to supervise abnormality of the external clocks.

- External OSC clock failure (clock stop) is detected, reset is asserted.
- External OSC frequency anomaly is detected, interrupt or reset is asserted.

- **Low-Voltage Detector (LVD)**

This Series include 2-stage monitoring of voltage on the VCC pins. When the voltage falls below the voltage has been set, Low-Voltage Detector generates an interrupt or reset.

- LVD1: error reporting via interrupt
- LVD2: auto-reset operation

- **Low-Power Mode**

Three power saving modes supported.

- SLEEP
- TIMER
- STOP

- **Debug**

- Serial Wire JTAG Debug Port (SWJ-DP)
- Embedded Trace Macrocells (ETM) provide comprehensive debug and trace facilities.

- **Power Supply**

Wide range voltage : VCC = 2.7V to 5.5V

**■ PRODUCT LINEUP**

● Memory size

Product name	MB9BF112N/R	MB9BF114N/R	MB9BF115N/R	MB9BF116R
MainFlash	128Kbyte	256Kbyte	384Kbyte	512Kbyte
WorkFlash	32Kbyte	32Kbyte	32Kbyte	32Kbyte
On-chip RAM	16Kbyte	32Kbyte	48Kbyte	64Kbyte
SRAM0	8Kbyte	16Kbyte	24Kbyte	32Kbyte
SRAM1	8Kbyte	16Kbyte	24Kbyte	32Kbyte

● Function

Product name		MB9BF112N MB9BF114N MB9BF115N MB9BF116N	MB9BF112R MB9BF114R MB9BF115R MB9BF116R
Pin count		100	120
CPU		Cortex-M3	
Freq.		144MHz	
Power supply voltage range		VCC: 2.7V to 5.5V	
DMAC		8ch.	
External Bus Interface		Addr: 25-bit (Max) R/Wdata: 8/16-bit (Max) CS: 8 (Max) Support: SRAM, NOR Flash	Addr: 25-bit (Max) R/Wdata: 8/16-bit (Max) CS: 8 (Max) Support: SRAM, NOR & NAND Flash
MF Serial Interface (UART/CSIO/LIN/I <sup>2</sup> C)		8ch. (Max)	
Base Timer (PWC/Reload timer/PWM/PPG)		8ch. (Max)	
MF-Timer	A/D activation compare	3ch.	3 units (Max)
	Input capture	4ch.	
	Free-run timer	3ch.	
	Output compare	6ch.	
	Waveform generator	3ch.	
	PPG	3ch.	
QPRC		3ch. (Max)	
Dual Timer		1 unit	
Real-Time Clock		1 unit	
Watch Counter		1 unit	
CRC Accelerator		Yes	
Watchdog timer		1ch. (SW) + 1ch. (HW)	
External Interrupts		16pins (Max) + NMI × 1	
I/O ports		83pins (Max)	103pins (Max)
12-bit A/D converter		16ch. (3 units)	
CSV (Clock Super Visor)		Yes	
LVD (Low-Voltage Detector)		2ch.	
Internal OSC	High-speed	4MHz (± 2%)	
	Low-speed	100kHz (Typ)	
Debug Function		SWJ-DP/ETM	

Note: All signals of the peripheral function in each product cannot be allocated by limiting the pins of package.  
It is necessary to use the port relocate function of the General I/O port according to your function use.



**■ PACKAGES**

Package \ Product name	MB9BF112N MB9BF114N MB9BF115N MB9BF116N	MB9BF112R MB9BF114R MB9BF115R MB9BF116R
QFP: FPT-100P-M36 (0.65mm pitch)	○	-
LQFP: FPT-100P-M20*/M23 (0.5mm pitch)	○	-
LQFP: FPT-120P-M21*/M37 (0.5mm pitch)	-	○
BGA: BGA-112P-M04 (0.8mm pitch)	○	-

○ : Supported

\* : ES product only

Note : See "■PACKAGE DIMENSIONS" for detailed information on each package.

## ■ PIN ASSIGNMENT

- FPT-100P-M20/M23

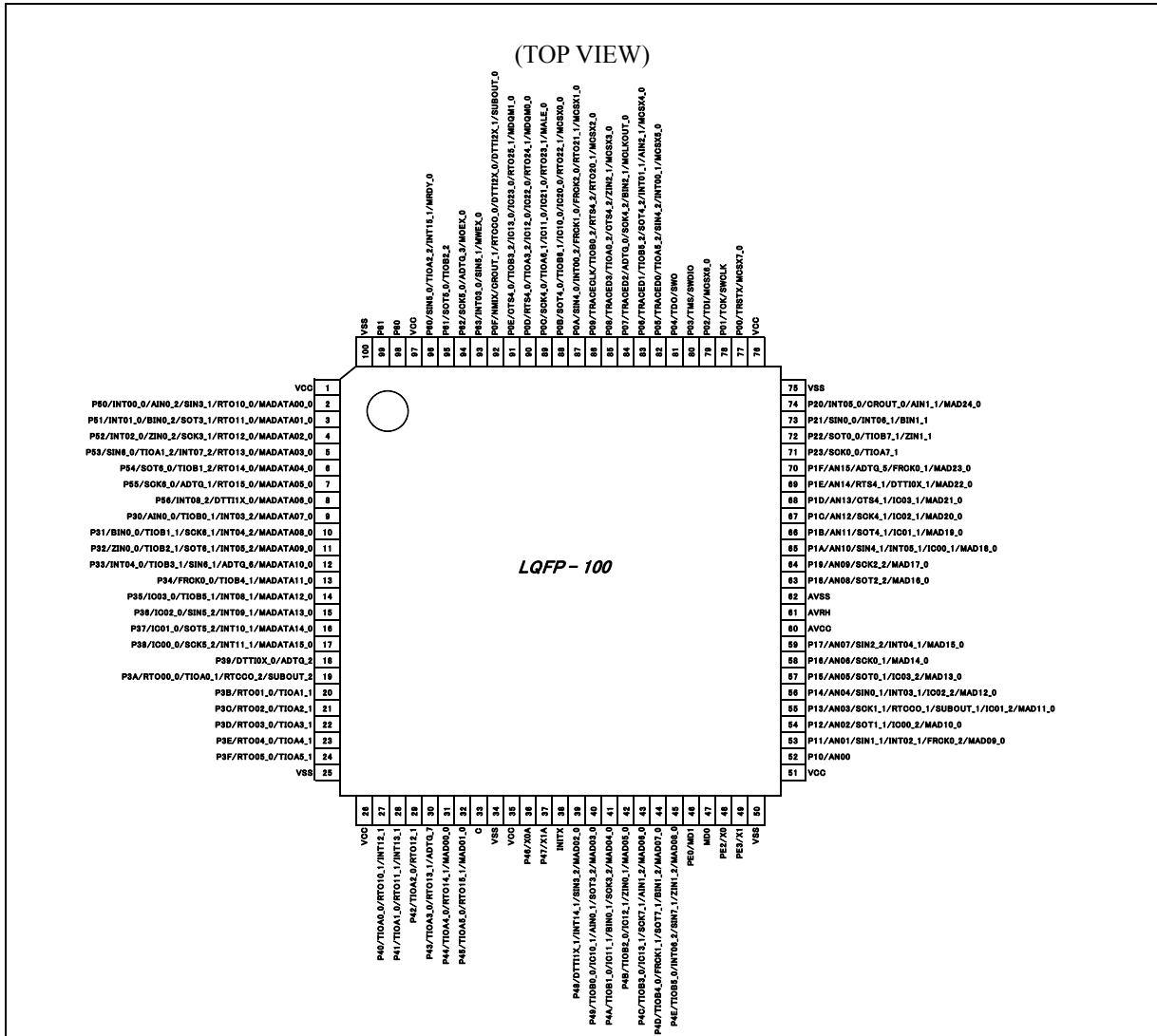

### <Note>

The number after the underscore ("\_") in pin names such as XXX\_1 and XXX\_2 indicates the relocated port number. For these pins, there are multiple pins that provide the same function for the same channel. Use the extended port function register (EPFR) to select the pin.

● FPT-120P-M21/M37

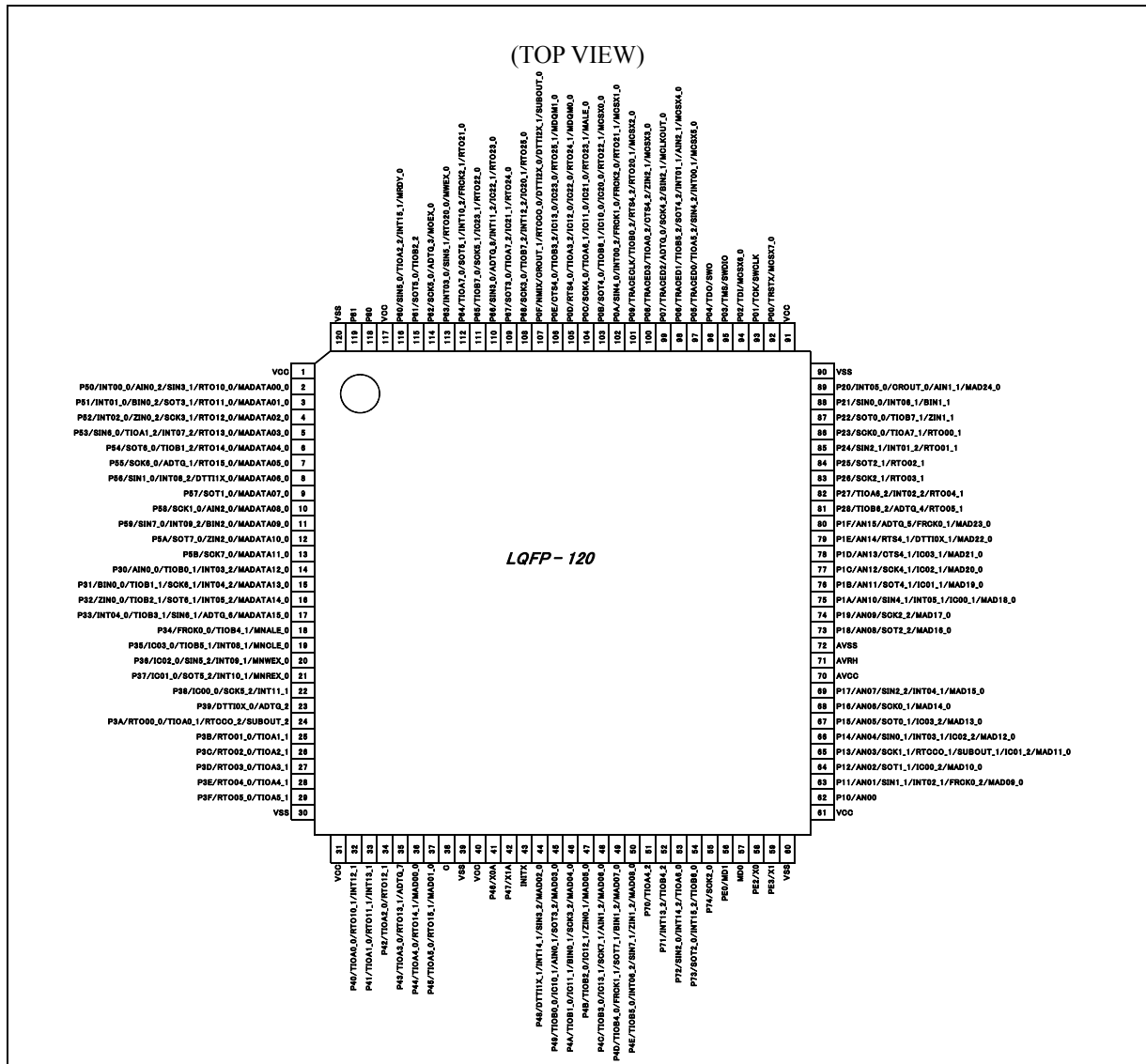

**<Note>**

The number after the underscore ("\_") in pin names such as XXX\_1 and XXX\_2 indicates the relocated port number. For these pins, there are multiple pins that provide the same function for the same channel. Use the extended port function register (EPFR) to select the pin.

● FPT-100P-M36

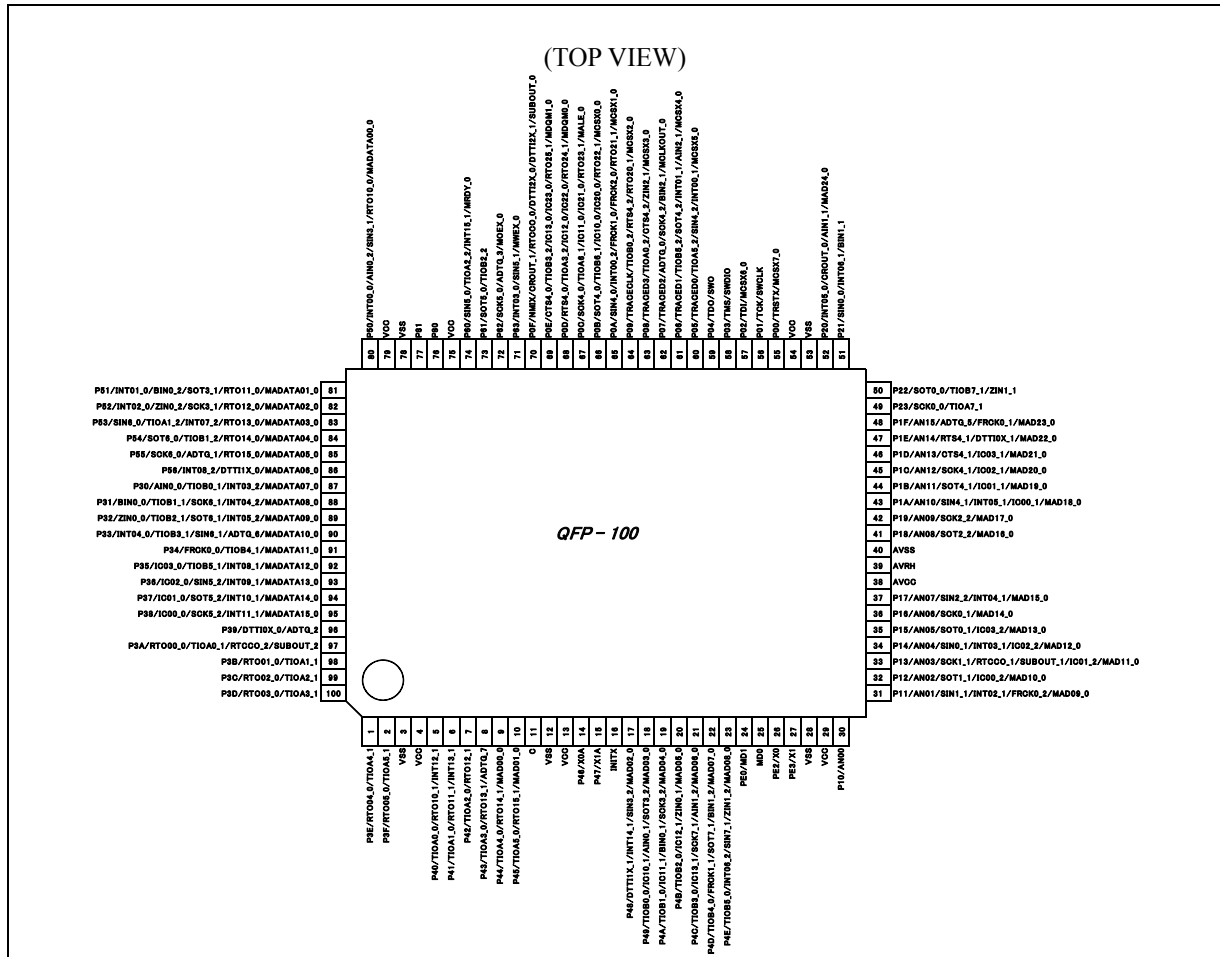

**<Note>**

The number after the underscore ("\_") in pin names such as XXX\_1 and XXX\_2 indicates the relocated port number. For these pins, there are multiple pins that provide the same function for the same channel. Use the extended port function register (EPFR) to select the pin.

● BGA-112P-M04

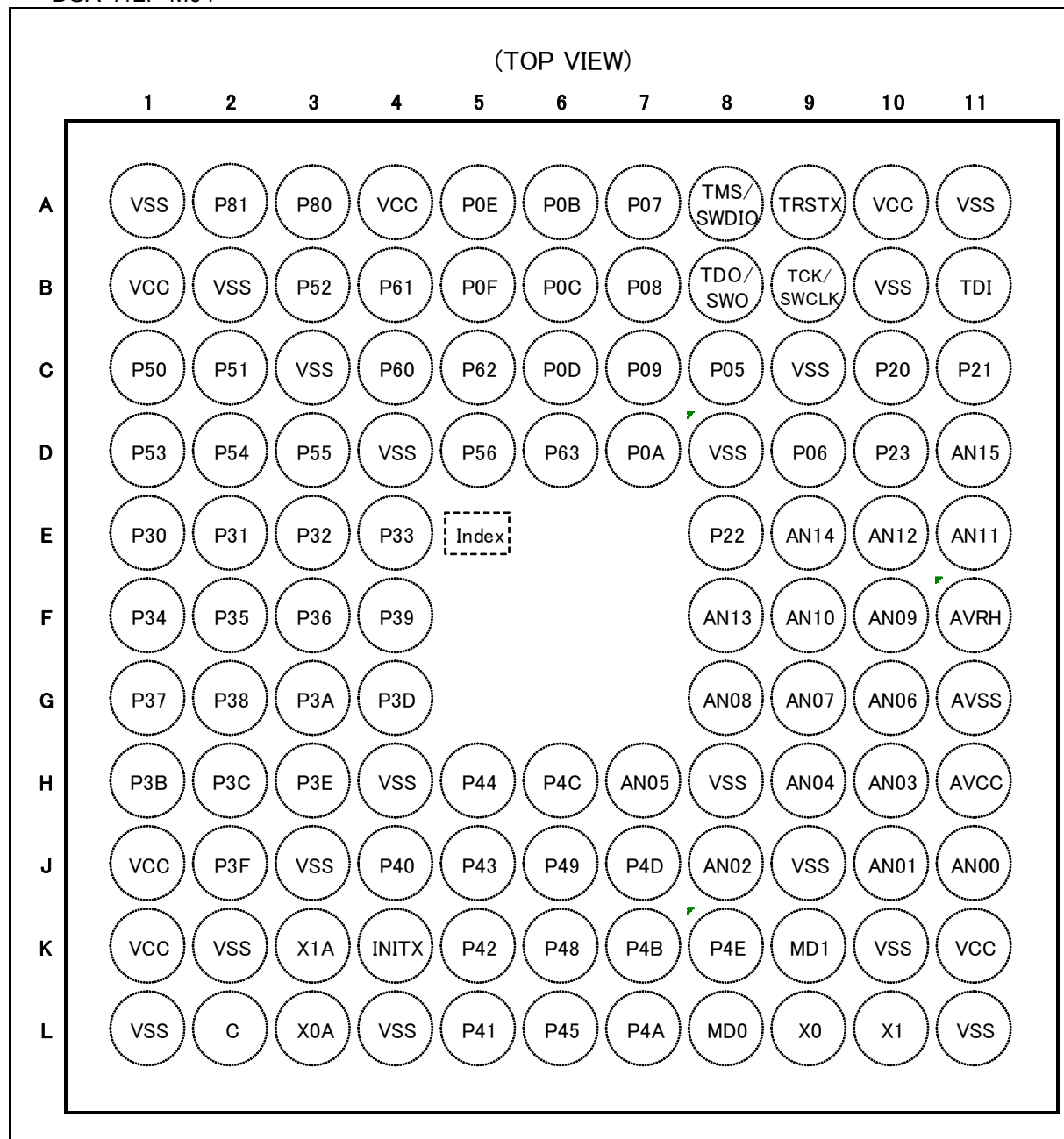

<Note>

The number after the underscore ("\_") in pin names such as XXX\_1 and XXX\_2 indicates the relocated port number. For these pins, there are multiple pins that provide the same function for the same channel. Use the extended port function register (EPFR) to select the pin.

## ■ PIN DESCRIPTION

The number after the underscore ("\_") in pin names such as XXX\_1 and XXX\_2 indicates the relocated port number. For these pins, there are multiple pins that provide the same function for the same channel. Use the extended port function register (EPFR) to select the pin.

Pin No				Pin Name	I/O circuit type	Pin state type
LQFP-100	BGA-112	LQFP-120	QFP-100			
1	B1	1	79	VCC	-	
2	C1	2	80	P50	E	H
				INT00_0		
				AIN0_2		
				SIN3_1		
				RTO10_0 (PPG10_0)		
				MADATAA00_0		
3	C2	3	81	P51	E	H
				INT01_0		
				BIN0_2		
				SOT3_1 (SDA3_1)		
				RTO11_0 (PPG10_0)		
				MADATAA01_0		
4	B3	4	82	P52	E	H
				INT02_0		
				ZIN0_2		
				SCK3_1 (SCL3_1)		
				RTO12_0 (PPG12_0)		
				MADATAA02_0		
5	D1	5	83	P53	E	H
				SIN6_0		
				TIOA1_2		
				INT07_2		
				RTO13_0 (PPG12_0)		
				MADATAA03_0		
6	D2	6	84	P54	E	I
				SOT6_0 (SDA6_0)		
				TIOB1_2		
				RTO14_0 (PPG14_0)		
				MADATAA04_0		

Pin No				Pin Name	I/O circuit type	Pin state type
LQFP-100	BGA-112	LQFP-120	QFP-100			
7	D3	7	85	P55	E	I
				SCK6_0 (SCL6_0)		
				ADTG_1		
				RTO15_0 (PPG14_0)		
				MADATA05_0		
8	D5	8	86	P56	E	H
				INT08_2		
				DTTIX_0		
				MADATA06_0		
-	-	-	-	SIN1_0 (120pin only)		
-	-	9	-	P57	E	I
				SOT1_0 (SDA1_0)		
				MADATA07_0		
-	-	10	-	P58	E	I
				SCK1_0 (SCL1_0)		
				AIN2_0		
				MADATA08_0		
-	-	11	-	P59	E	H
				SIN7_0		
				INT09_2		
				BIN2_0		
				MADATA09_0		
-	-	12	-	P5A	E	I
				SOT7_0 (SDA7_0)		
				ZIN2_0		
				MADATA10_0		
-	-	13	-	P5B	E	I
				SCK7_0 (SCL7_0)		
				MADATA11_0		

Pin No				Pin Name	I/O circuit type	Pin state type
LQFP-100	BGA-112	LQFP-120	QFP-100			
9	E1	14	87	P30	E	H
				AIN0_0		
				TIOB0_1		
				INT03_2		
		MADATA07_0 (100pin only)				
-	-	14	-	MADATA12_0 (120pin only)		
10	E2	15	88	P31	E	H
				BIN0_0		
				TIOB1_1		
				SCK6_1 (SCL6_1)		
				INT04_2		
		MADATA08_0 (100pin only)				
-	-	15	-	MADATA13_0 (120pin only)		
11	E3	16	89	P32	E	H
				ZIN0_0		
				TIOB2_1		
				SOT6_1 (SDA6_1)		
				INT05_2		
		MADATA09_0 (100pin only)				
-	-	16	-	MADATA14_0 (120pin only)		
12	E4	17	90	P33	E	H
				INT04_0		
				TIOB3_1		
				SIN6_1		
				ADTG_6		
				MADATA10_0 (100pin only)		
		-		-		
13	F1	18	91	P34	E	I
				FRCK0_0		
				TIOB4_1		
				MADATA11_0 (100pin only)		
		-		-		



Pin No				Pin Name	I/O circuit type	Pin state type
LQFP-100	BGA-112	LQFP-120	QFP-100			
14	F2	19	92	P35	E	H
				IC03_0		
				TIOB5_1		
				INT08_1		
		MADATA12_0 (100pin only)				
-	-	19	-	MNCLE_0 (120pin only)		
15	F3	20	93	P36	E	H
				IC02_0		
				SIN5_2		
				INT09_1		
		MADATA13_0 (100pin only)				
-	-	20	-	MNWEX_0 (120pin only)		
16	G1	21	94	P37	E	H
				IC01_0		
				SOT5_2 (SDA5_2)		
				INT10_1		
		MADATA14_0 (100pin only)				
-	-	21	-	MNREX_0 (120pin only)		
17	G2	22	95	P38	E	H
				IC00_0		
				SCK5_2 (SCL5_2)		
				INT11_1		
		MADATA15_0 (100pin only)				
-	-	-	-			
18	F4	23	96	P39	E	I
				DTTIOX_0		
				ADTG_2		
19	G3	24	97	P3A	G	I
				RTO00_0 (PPG00_0)		
				TIOA0_1		
				RTCCO_2		
				SUBOUT_2		
-	B2	-	-	VSS	-	

Pin No				Pin Name	I/O circuit type	Pin state type
LQFP-100	BGA-112	LQFP-120	QFP-100			
20	H1	25	98	P3B	G	I
				RTO01_0 (PPG00_0)		
				TIOA1_1		
21	H2	26	99	P3C	G	I
				RTO02_0 (PPG02_0)		
				TIOA2_1		
22	G4	27	100	P3D	G	I
				RTO03_0 (PPG02_0)		
				TIOA3_1		
23	H3	28	1	P3E	G	I
				RTO04_0 (PPG04_0)		
				TIOA4_1		
24	J2	29	2	P3F	G	I
				RTO05_0 (PPG04_0)		
				TIOA5_1		
25	L1	30	3	VSS	-	-
26	J1	31	4	VCC	-	-
27	J4	32	5	P40	G	H
				TIOA0_0		
				RTO10_1 (PPG10_1)		
				INT12_1		
28	L5	33	6	P41	G	H
				TIOA1_0		
				RTO11_1 (PPG10_1)		
				INT13_1		
29	K5	34	7	P42	G	I
				TIOA2_0		
				RTO12_1 (PPG12_1)		
30	J5	35	8	P43	G	I
				TIOA3_0		
				RTO13_1 (PPG12_1)		
				ADTG_7		
-	K2	-	-	VSS	-	-
-	J3	-	-	VSS	-	-
-	H4	-	-	VSS	-	-

Pin No				Pin Name	I/O circuit type	Pin state type
LQFP-100	BGA-112	LQFP-120	QFP-100			
31	H5	36	9	P44	G	I
				TIOA4_0		
				RTO14_1 (PPG14_1)		
				MAD00_0		
32	L6	37	10	P45	G	I
				TIOA5_0		
				RTO15_1 (PPG14_1)		
				MAD01_0		
33	L2	38	11	C	-	
34	L4	39	12	VSS	-	
35	K1	40	13	VCC	-	
36	L3	41	14	P46	D	M
				X0A		
37	K3	42	15	P47	D	N
				X1A		
38	K4	43	16	INITX	B	C
39	K6	44	17	P48	E	H
				DTT11X_1		
				INT14_1		
				SIN3_2 MAD02_0		
40	J6	45	18	P49	E	I
				TIOB0_0		
				IC10_1		
				AIN0_1		
				SOT3_2 (SDA3_2)		
				MAD03_0		
41	L7	46	19	P4A	E	I
				TIOB1_0		
				IC11_1		
				BIN0_1		
				SCK3_2 (SCL3_2)		
				MAD04_0		
42	K7	47	20	P4B	E	I
				TIOB2_0		
				IC12_1		
				ZIN0_1		
				MAD05_0		

Pin No				Pin Name	I/O circuit type	Pin state type
LQFP-100	BGA-112	LQFP-120	QFP-100			
43	H6	48	21	P4C	I*	I
				TIOB3_0		
				IC13_1		
				SCK7_1 (SCL7_1)		
				AIN1_2		
				MAD06_0		
44	J7	49	22	P4D	I*	I
				TIOB4_0		
				FRCK1_1		
				SOT7_1 (SDA7_1)		
				BIN1_2		
				MAD07_0		
45	K8	50	23	P4E	I*	H
				TIOB5_0		
				INT06_2		
				SIN7_1		
				ZIN1_2		
				MAD08_0		
-	-	51	-	P70	E	I
				TIOA4_2		
-	-	52	-	P71	E	H
				INT13_2		
				TIOB4_2		
-	-	53	-	P72	E	H
				SIN2_0		
				INT14_2		
				TIOA6_0		
-	-	54	-	P73	E	H
				SOT2_0 (SDA2_0)		
				INT15_2		
				TIOB6_0		
-	-	55	-	P74	E	I
				SCK2_0 (SCL2_0)		
46	K9	56	24	PE0	C	P
				MD1		
47	L8	57	25	MD0	P	D

Pin No				Pin Name	I/O circuit type	Pin state type
LQFP-100	BGA-112	LQFP-120	QFP-100			
48	L9	58	26	PE2	A	A
				X0		
49	L10	59	27	PE3	A	B
				X1		
50	L11	60	28	VSS	-	
51	K11	61	29	VCC	-	
52	J11	62	30	P10	F	K
				AN00		
53	J10	63	31	P11	F	L
				AN01		
				SIN1_1		
				INT02_1		
				FRCK0_2		
MAD09_0						
-	K10	-	-	VSS	-	
-	J9	-	-	VSS	-	
54	J8	64	32	P12	F	K
				AN02		
				SOT1_1 (SDA1_1)		
				IC00_2		
MAD10_0						
55	H10	65	33	P13	F	K
				AN03		
				SCK1_1 (SCL1_1)		
				RTCCO_1		
				SUBOUT_1		
				IC01_2		
MAD11_0						

Pin No				Pin Name	I/O circuit type	Pin state type
LQFP-100	BGA-112	LQFP-120	QFP-100			
56	H9	66	34	P14	F	L
				AN04		
				SIN0_1		
				INT03_1		
				IC02_2		
				MAD12_0		
57	H7	67	35	P15	F	K
				AN05		
				SOT0_1 (SDA0_1)		
				IC03_2		
				MAD13_0		
58	G10	68	36	P16	F	K
				AN06		
				SCK0_1 (SCL0_1)		
				MAD14_0		
59	G9	69	37	P17	F	L
				AN07		
				SIN2_2		
				INT04_1		
				MAD15_0		
60	H11	70	38	AVCC	-	
61	F11	71	39	AVRH	-	
62	G11	72	40	AVSS	-	
63	G8	73	41	P18	F	K
				AN08		
				SOT2_2 (SDA2_2)		
				MAD16_0		
64	F10	74	42	P19	F	K
				AN09		
				SCK2_2 (SCL2_2)		
				MAD17_0		
65	F9	75	43	P1A	F	L
				AN10		
				SIN4_1		
				INT05_1		
				IC00_1		
				MAD18_0		
-	H8	-	-	VSS	-	

Pin No				Pin Name	I/O circuit type	Pin state type
LQFP-100	BGA-112	LQFP-120	QFP-100			
66	E11	76	44	P1B	F	K
				AN11		
				SOT4_1 (SDA4_1)		
				IC01_1		
				MAD19_0		
67	E10	77	45	P1C	F	K
				AN12		
				SCK4_1 (SCL4_1)		
				IC02_1		
				MAD20_0		
68	F8	78	46	P1D	F	K
				AN13		
				CTS4_1		
				IC03_1		
				MAD21_0		
69	E9	79	47	P1E	F	K
				AN14		
				RTS4_1		
				DTTIOX_1		
				MAD22_0		
70	D11	80	48	P1F	F	K
				AN15		
				ADTG_5		
				FRCK0_1		
				MAD23_0		
-	-	81	-	P28	E	I
				TIOB6_2		
				ADTG_4		
				RTO05_1 (PPG04_1)		
-	-	82	-	P27	E	H
				TIOA6_2		
				INT02_2		
				RTO04_1 (PPG04_1)		
-	-	83	-	P26	E	I
				SCK2_1 (SCL2_1)		
				RTO03_1 (PPG02_1)		

Pin No				Pin Name	I/O circuit type	Pin state type
LQFP-100	BGA-112	LQFP-120	QFP-100			
-	-	84	-	P25	E	I
				SOT2_1 (SDA2_1)		
				RTO02_1 (PPG02_1)		
-	B10	-	-	VSS	-	-
-	C9	-	-	VSS	-	-
-	-	85	-	P24	E	H
				SIN2_1		
				INT01_2		
				RTO01_1 (PPG00_1)		
71	D10	86	49	P23	E	I
				SCK0_0 (SCL0_0)		
				TIOA7_1		
-	-	-	-	RTO00_1 (PPG00_1)	-	-
72	E8	87	50	P22	E	I
				SOT0_0 (SDA0_0)		
				TIOB7_1		
				ZIN1_1		
73	C11	88	51	P21	E	H
				SIN0_0		
				INT06_1		
				BIN1_1		
74	C10	89	52	P20	E	H
				INT05_0		
				CROUT_0		
				AIN1_1		
				MAD24_0		
75	A11	90	53	VSS	-	-
76	A10	91	54	VCC	-	-
77	A9	92	55	P00	E	E
				TRSTX		
				MCSX7_0		
78	B9	93	56	P01	E	E
				TCK		
				SWCLK		



Pin No				Pin Name	I/O circuit type	Pin state type
LQFP-100	BGA-112	LQFP-120	QFP-100			
79	B11	94	57	P02	E	E
				TDI		
				MCSX6_0		
80	A8	95	58	P03	E	E
				TMS		
				SWDIO		
81	B8	96	59	P04	E	E
				TDO		
				SWO		
82	C8	97	60	P05	E	F
				TRACED0		
				TIOA5_2		
				SIN4_2		
				INT00_1		
MCSX5_0						
-	D8	-	-	VSS	-	-
83	D9	98	61	P06	E	F
				TRACED1		
				TIOB5_2		
				SOT4_2 (SDA4_2)		
				INT01_1		
				AIN2_1		
MCSX4_0						
84	A7	99	62	P07	E	G
				TRACED2		
				ADTG_0		
				SCK4_2 (SCL4_2)		
				BIN2_1		
				MCLKOUT_0		
85	B7	100	63	P08	E	G
				TRACED3		
				TIOA0_2		
				CTS4_2		
				ZIN2_1		
MCSX3_0						
86	C7	101	64	P09	E	G
				TRACECLK		
				TIOB0_2		
				RTS4_2		
				RTO20_1 (PPG20_1)		
MCSX2_0						

Pin No				Pin Name	I/O circuit type	Pin state type
LQFP-100	BGA-112	LQFP-120	QFP-100			
87	D7	102	65	P0A	I*	H
				SIN4_0		
				INT00_2		
				FRCK1_0		
				FRCK2_0		
				RTO21_1 (PPG20_1)		
				MCSX1_0		
88	A6	103	66	P0B	I*	I
				SOT4_0 (SDA4_0)		
				TIOB6_1		
				IC10_0		
				IC20_0		
				RTO22_1 (PPG22_1)		
				MCSX0_0		
89	B6	104	67	P0C	I*	I
				SCK4_0 (SCL4_0)		
				TIOA6_1		
				IC11_0		
				IC21_0		
				RTO23_1		
				MALE_0		
90	C6	105	68	P0D	E	I
				RTS4_0		
				TIOA3_2		
				IC12_0		
				IC22_0		
				RTO24_1 (PPG24_1)		
				MDQM0_0		
91	A5	106	69	P0E	E	I
				CTS4_0		
				TIOB3_2		
				IC13_0		
				IC23_0		
				RTO25_1 (PPG24_1)		
				MDQM1_0		
-	D4	-	-	VSS	-	-
-	C3	-	-	VSS	-	-

Pin No				Pin Name	I/O circuit type	Pin state type
LQFP-100	BGA-112	LQFP-120	QFP-100			
92	B5	107	70	P0F	E	J
				NMIX		
				CROUT_1		
				RTCCO_0		
				SUBOUT_0		
				DTI2X_0		
				DTI2X_1		
-	-	108	-	P68	E	H
				SCK3_0 (SCL3_0)		
				TIOB7_2		
				INT12_2		
				IC20_1		
				RTO25_0 (PPG24_0)		
-	-	109	-	P67	E	I
				SOT3_0 (SDA3_0)		
				TIOA7_2		
				IC21_1		
				RTO24_0 (PPG24_0)		
-	-	110	-	P66	E	H
				SIN3_0		
				ADTG_8		
				INT11_2		
				IC22_1		
				RTO23_0 (PPG22_0)		
-	-	111	-	P65	E	I
				TIOB7_0		
				SCK5_1 (SCL5_1)		
				IC23_1		
				RTO22_0 (PPG22_0)		
-	-	112	-	P64	E	H
				TIOA7_0		
				SOT5_1 (SDA5_1)		
				INT10_2		
				FRCK2_1		
				RTO21_0 (PPG20_0)		

Pin No				Pin Name	I/O circuit type	Pin state type
LQFP-100	BGA-112	LQFP-120	QFP-100			
93	D6	113	71	P63	E	H
				INT03_0		
				SIN5_1		
				MWEX_0		
-	-	-	-	RTO20_0 (PPG20_0)		
94	C5	114	72	P62	E	I
				SCK5_0 (SCL5_0)		
				ADTG_3		
				MOEX_0		
95	B4	115	73	P61	E	I
				SOT5_0 (SDA5_0)		
				TIOB2_2		
96	C4	116	74	P60	I*	H
				SIN5_0		
				TIOA2_2		
				INT15_1		
				MRDY_0		
97	A4	117	75	VCC	-	
98	A3	118	76	P80	H	O
99	A2	119	77	P81	H	O
100	A1	120	78	VSS	-	

\*: 5V tolerant I/O

■ SIGNAL DESCRIPTION

Module	Pin name	Function	Pin No				
			LQFP-100	BGA-112	LQFP-120	QFP-100	
ADC	ADTG_0	A/D converter external trigger input pin	84	A7	99	62	
	ADTG_1		7	D3	7	85	
	ADTG_2		18	F4	23	96	
	ADTG_3		94	C5	114	72	
	ADTG_4		-	-	81	-	
	ADTG_5		70	D11	80	48	
	ADTG_6		12	E4	17	90	
	ADTG_7		30	J5	35	8	
	ADTG_8		-	-	110	-	
	AN00	A/D converter analog input pin. ANxx describes ADC ch.xx.	52	J11	62	30	
	AN01		53	J10	63	31	
	AN02		54	J8	64	32	
	AN03		55	H10	65	33	
	AN04		56	H9	66	34	
	AN05		57	H7	67	35	
	AN06		58	G10	68	36	
	AN07		59	G9	69	37	
	AN08		63	G8	73	41	
	AN09		64	F10	74	42	
	AN10		65	F9	75	43	
	AN11		66	E11	76	44	
	AN12		67	E10	77	45	
	AN13		68	F8	78	46	
	AN14		69	E9	79	47	
	AN15		70	D11	80	48	
	Base Timer 0	TIOA0_0	Base timer ch.0 TIOA pin	27	J4	32	5
		TIOA0_1		19	G3	24	97
		TIOA0_2		85	B7	100	63
TIOB0_0		Base timer ch.0 TIOB pin	40	J6	45	18	
TIOB0_1			9	E1	14	87	
TIOB0_2			86	C7	101	64	
Base Timer 1	TIOA1_0	Base timer ch.1 TIOA pin	28	L5	33	6	
	TIOA1_1		20	H1	25	98	
	TIOA1_2		5	D1	5	83	
	TIOB1_0	Base timer ch.1 TIOB pin	41	L7	46	19	
	TIOB1_1		10	E2	15	88	
	TIOB1_2		6	D2	6	84	
Base Timer 2	TIOA2_0	Base timer ch.2 TIOA pin	29	K5	34	7	
	TIOA2_1		21	H2	26	99	
	TIOA2_2		96	C4	116	74	
	TIOB2_0	Base timer ch.2 TIOB pin	42	K7	47	20	
	TIOB2_1		11	E3	16	89	
	TIOB2_2		95	B4	115	73	

Module	Pin name	Function	Pin No			
			LQFP-100	BGA-112	LQFP-120	QFP-100
Base Timer 3	TIOA3_0	Base timer ch.3 TIOA pin	30	J5	35	8
	TIOA3_1		22	G4	27	100
	TIOA3_2		90	C6	105	68
	TIOB3_0	Base timer ch.3 TIOB pin	43	H6	48	21
	TIOB3_1		12	E4	17	90
	TIOB3_2		91	A5	106	69
Base Timer 4	TIOA4_0	Base timer ch.4 TIOA pin	31	H5	36	9
	TIOA4_1		23	H3	28	1
	TIOA4_2		-	-	51	-
	TIOB4_0	Base timer ch.4 TIOB pin	44	J7	49	22
	TIOB4_1		13	F1	18	91
	TIOB4_2		-	-	52	-
Base Timer 5	TIOA5_0	Base timer ch.5 TIOA pin	32	L6	37	10
	TIOA5_1		24	J2	29	2
	TIOA5_2		82	C8	97	60
	TIOB5_0	Base timer ch.5 TIOB pin	45	K8	50	23
	TIOB5_1		14	F2	19	92
	TIOB5_2		83	D9	98	61
Base Timer 6	TIOA6_0	Base timer ch.6 TIOA pin	-	-	53	-
	TIOA6_1		89	B6	104	67
	TIOA6_2		-	-	82	-
	TIOB6_0	Base timer ch.6 TIOB pin	-	-	54	-
	TIOB6_1		88	A6	103	66
	TIOB6_2		-	-	81	-
Base Timer 7	TIOA7_0	Base timer ch.7 TIOA pin	-	-	112	-
	TIOA7_1		71	D10	86	49
	TIOA7_2		-	-	109	-
	TIOB7_0	Base timer ch.7 TIOB pin	-	-	111	-
	TIOB7_1		72	E8	87	50
	TIOB7_2		-	-	108	-

Module	Pin name	Function	Pin No			
			LQFP-100	BGA-112	LQFP-120	QFP-100
Debugger	SWCLK	Serial wire debug interface clock input pin	78	B9	93	56
	SWDIO	Serial wire debug interface data input / output pin	80	A8	95	58
	SWO	Serial wire viewer output pin	81	B8	96	59
	TCK	J-TAG test clock input pin	78	B9	93	56
	TDI	J-TAG test data input pin	79	B11	94	57
	TDO	J-TAG debug data output pin	81	B8	96	59
	TMS	J-TAG test mode state input/output pin	80	A8	95	58
	TRACECLK	Trace CLK output pin of ETM	86	C7	101	64
	TRACED0	Trace data output pin of ETM	82	C8	97	60
	TRACED1		83	D9	98	61
	TRACED2		84	A7	99	62
	TRACED3		85	B7	100	63
	TRSTX	J-TAG test reset input pin	77	A9	92	55
External Bus	MAD00_0	External bus interface address bus	31	H5	36	9
	MAD01_0		32	L6	37	10
	MAD02_0		39	K6	44	17
	MAD03_0		40	J6	45	18
	MAD04_0		41	L7	46	19
	MAD05_0		42	K7	47	20
	MAD06_0		43	H6	48	21
	MAD07_0		44	J7	49	22
	MAD08_0		45	K8	50	23
	MAD09_0		53	J10	63	31
	MAD10_0		54	J8	64	32
	MAD11_0		55	H10	65	33
	MAD12_0		56	H9	66	34
	MAD13_0		57	H7	67	35
	MAD14_0		58	G10	68	36
	MAD15_0		59	G9	69	37
	MAD16_0		63	G8	73	41
	MAD17_0		64	F10	74	42
	MAD18_0		65	F9	75	43
	MAD19_0		66	E11	76	44
	MAD20_0		67	E10	77	45
	MAD21_0		68	F8	78	46
	MAD22_0		69	E9	79	47
	MAD23_0		70	D11	80	48
	MAD24_0	74	C10	89	52	
	MCSX0_0	External bus interface chip select output pin	88	A6	103	66
	MCSX1_0		87	D7	102	65
	MCSX2_0		86	C7	101	64
	MCSX3_0		85	B7	100	63
	MCSX4_0		83	D9	98	61
	MCSX5_0		82	C8	97	60
	MCSX6_0		79	B11	94	57
MCSX7_0	77		A9	92	55	

Module	Pin name	Function	Pin No			
			LQFP-100	BGA-112	LQFP-120	QFP-100
External Bus	MADATA0_0	External bus interface data bus (Address / data multiplex bus)	2	C1	2	80
	MADATA1_0		3	C2	3	81
	MADATA2_0		4	B3	4	82
	MADATA3_0		5	D1	5	83
	MADATA4_0		6	D2	6	84
	MADATA5_0		7	D3	7	85
	MADATA6_0		8	D5	8	86
	MADATA7_0		9	E1	9	87
	MADATA8_0		10	E2	10	88
	MADATA9_0		11	E3	11	89
	MADATA10_0		12	E4	12	90
	MADATA11_0		13	F1	13	91
	MADATA12_0		14	F2	14	92
	MADATA13_0		15	F3	15	93
	MADATA14_0		16	G1	16	94
	MADATA15_0		17	G2	17	95
	MDQM0_0		External bus interface byte mask signal output pin	90	C6	105
	MDQM1_0		91	A5	106	69
	MALE_0	External bus interface Address Latch enable output signal for multiplex	89	B6	104	67
	MRDY_0	External bus interface external RDY input signal	96	C4	116	74
	MCLKOUT_0	External bus interface external clock output pin	84	A7	99	62
	MNALE_0	External bus interface ALE signal to control NAND Flash output pin	-	-	18	-
	MNCLE_0	External bus interface CLE signal to control NAND Flash output pin	-	-	19	-
MNREX_0	External bus interface read enable signal to control NAND Flash	-	-	21	-	
MNWEX_0	External bus interface write enable signal to control NAND Flash	-	-	20	-	
MOEX_0	External bus interface read enable signal for SRAM	94	C5	114	72	
MWEX_0	External bus interface write enable signal for SRAM	93	D6	113	71	



Module	Pin name	Function	Pin No			
			LQFP-100	BGA-112	LQFP-120	QFP-100
External Interrupt	INT00_0	External interrupt request 00 input pin	2	C1	2	80
	INT00_1		82	C8	97	60
	INT00_2		87	D7	102	65
	INT01_0	External interrupt request 01 input pin	3	C2	3	81
	INT01_1		83	D9	98	61
	INT01_2		-	-	85	-
	INT02_0	External interrupt request 02 input pin	4	B3	4	82
	INT02_1		53	J10	63	31
	INT02_2		-	-	82	-
	INT03_0	External interrupt request 03 input pin	93	D6	113	71
	INT03_1		56	H9	66	34
	INT03_2		9	E1	14	87
	INT04_0	External interrupt request 04 input pin	12	E4	17	90
	INT04_1		59	G9	69	37
	INT04_2		10	E2	15	88
	INT05_0	External interrupt request 05 input pin	74	C10	89	52
	INT05_1		65	F9	75	43
	INT05_2		11	E3	16	89
	INT06_1	External interrupt request 06 input pin	73	C11	88	51
	INT06_2		45	K8	50	23
	INT07_2	External interrupt request 07 input pin	5	D1	5	83
	INT08_1	External interrupt request 08 input pin	14	F2	19	92
	INT08_2		8	D5	8	86
	INT09_1	External interrupt request 09 input pin	15	F3	20	93
	INT09_2		-	-	11	-
	INT10_1	External interrupt request 10 input pin	16	G1	21	94
	INT10_2		-	-	112	-
	INT11_1	External interrupt request 11 input pin	17	G2	22	95
	INT11_2		-	-	110	-
	INT12_1	External interrupt request 12 input pin	27	J4	32	5
	INT12_2		-	-	108	-
	INT13_1	External interrupt request 13 input pin	28	L5	33	6
	INT13_2		-	-	52	-
INT14_1	External interrupt request 14 input pin	39	K6	44	17	
INT14_2		-	-	53	-	
INT15_1	External interrupt request 15 input pin	96	C4	116	74	
INT15_2		-	-	54	-	
NMIX	Non-Maskable Interrupt input pin	92	B5	107	70	

Module	Pin name	Function	Pin No			
			LQFP-100	BGA-112	LQFP-120	QFP-100
GPIO	P00	General-purpose I/O port 0	77	A9	92	55
	P01		78	B9	93	56
	P02		79	B11	94	57
	P03		80	A8	95	58
	P04		81	B8	96	59
	P05		82	C8	97	60
	P06		83	D9	98	61
	P07		84	A7	99	62
	P08		85	B7	100	63
	P09		86	C7	101	64
	P0A		87	D7	102	65
	P0B		88	A6	103	66
	P0C		89	B6	104	67
	P0D		90	C6	105	68
	P0E		91	A5	106	69
	P0F		92	B5	107	70
	P10	General-purpose I/O port 1	52	J11	62	30
	P11		53	J10	63	31
	P12		54	J8	64	32
	P13		55	H10	65	33
	P14		56	H9	66	34
	P15		57	H7	67	35
	P16		58	G10	68	36
	P17		59	G9	69	37
	P18		63	G8	73	41
	P19		64	F10	74	42
	P1A		65	F9	75	43
	P1B		66	E11	76	44
P1C	67	E10	77	45		
P1D	68	F8	78	46		
P1E	69	E9	79	47		
P1F	70	D11	80	48		
P20	General-purpose I/O port 2	74	C10	89	52	
P21		73	C11	88	51	
P22		72	E8	87	50	
P23		71	D10	86	49	
P24		-	-	85	-	
P25		-	-	84	-	
P26		-	-	83	-	
P27		-	-	82	-	
P28	-	-	81	-		

Module	Pin name	Function	Pin No				
			LQFP-100	BGA-112	LQFP-120	QFP-100	
GPIO	P30	General-purpose I/O port 3	9	E1	14	87	
	P31		10	E2	15	88	
	P32		11	E3	16	89	
	P33		12	E4	17	90	
	P34		13	F1	18	91	
	P35		14	F2	19	92	
	P36		15	F3	20	93	
	P37		16	G1	21	94	
	P38		17	G2	22	95	
	P39		18	F4	23	96	
	P3A		19	G3	24	97	
	P3B		20	H1	25	98	
	P3C		21	H2	26	99	
	P3D		22	G4	27	100	
	P3E		23	H3	28	1	
	P3F		24	J2	29	2	
	P40		27	General-purpose I/O port 4	J4	32	5
	P41		28		L5	33	6
	P42		29		K5	34	7
	P43		30		J5	35	8
	P44		31		H5	36	9
	P45		32		L6	37	10
	P46		36		L3	41	14
	P47		37		K3	42	15
	P48	39	K6		44	17	
	P49	40	J6		45	18	
	P4A	41	L7		46	19	
	P4B	42	K7		47	20	
	P4C	43	H6		48	21	
	P4D	44	J7		49	22	
	P4E	45	K8		50	23	
	P50	2	General-purpose I/O port 5		C1	2	80
	P51	3		C2	3	81	
	P52	4		B3	4	82	
	P53	5		D1	5	83	
	P54	6		D2	6	84	
	P55	7		D3	7	85	
	P56	8		D5	8	86	
	P57	-		-	9	-	
	P58	-		-	10	-	
	P59	-		-	11	-	
	P5A	-		-	12	-	
	P5B	-		-	13	-	

Module	Pin name	Function	Pin No			
			LQFP-100	BGA-112	LQFP-120	QFP-100
GPIO	P60	General-purpose I/O port 6	96	C4	116	74
	P61		95	B4	115	73
	P62		94	C5	114	72
	P63		93	D6	113	71
	P64		-	-	112	-
	P65		-	-	111	-
	P66		-	-	110	-
	P67		-	-	109	-
	P68		-	-	108	-
	P70	General-purpose I/O port 7	-	-	51	-
	P71		-	-	52	-
	P72		-	-	53	-
	P73		-	-	54	-
	P74		-	-	55	-
	P80	General-purpose I/O port 8	98	A3	118	76
	P81		99	A2	119	77
	PE0	General-purpose I/O port E	46	K9	56	24
	PE2		48	L9	58	26
PE3	49		L10	59	27	
Multi-function Serial 0	SIN0_0	Multi-function serial interface ch.0 input pin	73	C11	88	51
	SIN0_1		56	H9	66	34
	SOT0_0 (SDA0_0)	Multi-function serial interface ch.0 output pin. This pin operates as SOT0 when it is used in a UART/CSIO/LIN (operation modes 0 to 3) and as SDA0 when it is used in an I <sup>2</sup> C (operation mode 4).	72	E8	87	50
	SOT0_1 (SDA0_1)	Multi-function serial interface ch.0 output pin. This pin operates as SOT0 when it is used in a UART/CSIO/LIN (operation modes 0 to 3) and as SDA0 when it is used in an I <sup>2</sup> C (operation mode 4).	57	H7	67	35
	SCK0_0 (SCL0_0)	Multi-function serial interface ch.0 clock I/O pin. This pin operates as SCK0 when it is used in a UART/CSIO/LIN (operation modes 0 to 3) and as SCL0 when it is used in an I <sup>2</sup> C (operation mode 4).	71	D10	86	49
	SCK0_1 (SCL0_1)	Multi-function serial interface ch.0 clock I/O pin. This pin operates as SCK0 when it is used in a UART/CSIO/LIN (operation modes 0 to 3) and as SCL0 when it is used in an I <sup>2</sup> C (operation mode 4).	58	G10	68	36
Multi-function Serial 1	SIN1_0	Multi-function serial interface ch.1 input pin	-	-	8	-
	SIN1_1		53	J10	63	31
	SOT1_0 (SDA1_0)	Multi-function serial interface ch.1 output pin. This pin operates as SOT1 when it is used in a UART/CSIO/LIN (operation modes 0 to 3) and as SDA1 when it is used in an I <sup>2</sup> C (operation mode 4).	-	-	9	-
	SOT1_1 (SDA1_1)	Multi-function serial interface ch.1 output pin. This pin operates as SOT1 when it is used in a UART/CSIO/LIN (operation modes 0 to 3) and as SDA1 when it is used in an I <sup>2</sup> C (operation mode 4).	54	J8	64	32
	SCK1_0 (SCL1_0)	Multi-function serial interface ch.1 clock I/O pin. This pin operates as SCK1 when it is used in a CSIO (operation modes 4) and as SCL1 when it is used in an I <sup>2</sup> C (operation mode 4).	-	-	10	-
	SCK1_1 (SCL1_1)	Multi-function serial interface ch.1 clock I/O pin. This pin operates as SCK1 when it is used in a CSIO (operation modes 4) and as SCL1 when it is used in an I <sup>2</sup> C (operation mode 4).	55	H10	65	33

Module	Pin name	Function	Pin No.			
			LQFP-100	BGA-112	LQFP-120	QFP-100
Multi-function Serial 2	SIN2_0	Multi-function serial interface ch.2 input pin	-	-	53	-
	SIN2_1		-	-	85	-
	SIN2_2		59	G9	69	37
	SOT2_0 (SDA2_0)	Multi-function serial interface ch.2 output pin.	-	-	54	-
	SOT2_1 (SDA2_1)	This pin operates as SOT2 when it is used in a UART/CSIO/LIN (operation modes 0 to 3) and as SDA2 when it is used in an I <sup>2</sup> C (operation mode 4).	-	-	84	-
	SOT2_2 (SDA2_2)		63	G8	73	41
	SCK2_0 (SCL2_0)	Multi-function serial interface ch.2 clock I/O pin.	-	-	55	-
	SCK2_1 (SCL2_1)	This pin operates as SCK2 when it is used in a CSIO (operation modes 2) and as SCL2 when it is used in an I <sup>2</sup> C (operation mode 4).	-	-	83	-
	SCK2_2 (SCL2_2)		64	F10	74	42
Multi-function Serial 3	SIN3_0	Multi-function serial interface ch.3 input pin	-	-	110	-
	SIN3_1		2	C1	2	80
	SIN3_2		39	K6	44	17
	SOT3_0 (SDA3_0)	Multi-function serial interface ch.3 output pin.	-	-	109	-
	SOT3_1 (SDA3_1)	This pin operates as SOT3 when it is used in a UART/CSIO/LIN (operation modes 0 to 3) and as SDA3 when it is used in an I <sup>2</sup> C (operation mode 4).	3	C2	3	81
	SOT3_2 (SDA3_2)		40	J6	45	18
	SCK3_0 (SCL3_0)	Multi-function serial interface ch.3 clock I/O pin.	-	-	108	-
	SCK3_1 (SCL3_1)	This pin operates as SCK3 when it is used in a CSIO (operation modes 2) and as SCL3 when it is used in an I <sup>2</sup> C (operation mode 4).	4	B3	4	82
	SCK3_2 (SCL3_2)		41	L7	46	19

Module	Pin name	Function	Pin No			
			LQFP-100	BGA-112	LQFP-120	QFP-100
Multi-function Serial 4	SIN4_0	Multi-function serial interface ch.4 input pin	87	D7	102	65
	SIN4_1		65	F9	75	43
	SIN4_2		82	C8	97	60
	SOT4_0 (SDA4_0)	Multi-function serial interface ch.4 output pin.	88	A6	103	66
	SOT4_1 (SDA4_1)	This pin operates as SOT4 when it is used in a UART/CSIO/LIN (operation modes 0 to 3) and as SDA4 when it is used in an I <sup>2</sup> C (operation mode 4).	66	E11	76	44
	SOT4_2 (SDA4_2)		83	D9	98	61
	SCK4_0 (SCL4_0)		Multi-function serial interface ch.4 clock I/O pin.	89	B6	104
	SCK4_1 (SCL4_1)	This pin operates as SCK4 when it is used in a CSIO (operation modes 2) and as SCL4 when it is used in an I <sup>2</sup> C (operation mode 4).	67	E10	77	45
	SCK4_2 (SCL4_2)		84	A7	99	62
	RTS4_0		Multi-function serial interface ch.4 RTS output pin	90	C6	105
	RTS4_1	69		E9	79	47
	RTS4_2	86		C7	101	64
	CTS4_0	Multi-function serial interface ch.4 CTS input pin	91	A5	106	69
	CTS4_1		68	F8	78	46
	CTS4_2		85	B7	100	63
Multi-function Serial 5	SIN5_0	Multi-function serial interface ch.5 input pin	96	C4	116	74
	SIN5_1		93	D6	113	93
	SIN5_2		15	F3	20	93
	SOT5_0 (SDA5_0)	Multi-function serial interface ch.5 output pin.	95	B4	115	73
	SOT5_1 (SDA5_1)	This pin operates as SOT5 when it is used in a UART/CSIO/LIN (operation modes 0 to 3) and as SDA5 when it is used in an I <sup>2</sup> C (operation mode 4).	-	-	112	-
	SOT5_2 (SDA5_2)		16	G1	21	94
	SCK5_0 (SCL5_0)		Multi-function serial interface ch.5 clock I/O pin.	94	C5	114
	SCK5_1 (SCL5_1)	This pin operates as SCK5 when it is used in a CSIO (operation modes 2) and as SCL5 when it is used in an I <sup>2</sup> C (operation mode 4).	-	-	111	-
SCK5_2 (SCL5_2)	17		G2	22	95	

Module	Pin name	Function	Pin No			
			LQFP-100	BGA-112	LQFP-120	QFP-100
Multi-function Serial 6	SIN6_0	Multi-function serial interface ch.6 input pin	5	D1	5	83
	SIN6_1		12	E4	17	90
	SOT6_0 (SDA6_0)	Multi-function serial interface ch.6 output pin.	6	D2	6	84
	SOT6_1 (SDA6_1)	This pin operates as SOT6 when it is used in a UART/CSIO/LIN (operation modes 0 to 3) and as SDA6 when it is used in an I <sup>2</sup> C (operation mode 4).	11	E3	16	89
	SCK6_0 (SCL6_0)	Multi-function serial interface ch.6 clock I/O pin.	7	D3	7	85
	SCK6_1 (SCL6_1)	This pin operates as SCK6 when it is used in a CSIO (operation modes 2) and as SCL6 when it is used in an I <sup>2</sup> C (operation mode 4).	10	E2	15	88
Multi-function Serial 7	SIN7_0	Multi-function serial interface ch.7 input pin	-	-	11	-
	SIN7_1		45	K8	50	23
	SOT7_0 (SDA7_0)	Multi-function serial interface ch.7 output pin.	-	-	12	-
	SOT7_1 (SDA7_1)	This pin operates as SOT7 when it is used in a UART/CSIO/LIN (operation modes 0 to 3) and as SDA7 when it is used in an I <sup>2</sup> C (operation mode 4).	44	J7	49	22
	SCK7_0 (SCL7_0)	Multi-function serial interface ch.7 clock I/O pin.	-	-	13	-
	SCK7_1 (SCL7_1)	This pin operates as SCK7 when it is used in a CSIO (operation modes 2) and as SCL7 when it is used in an I <sup>2</sup> C (operation mode 4).	43	H6	48	21

Module	Pin name	Function	Pin No				
			LQFP-100	BGA-112	LQFP-120	QFP-100	
Multi-function Timer 0	DTTI0X_0	Input signal controlling wave form generator outputs RTO00 to RTO05 of Multi-function timer 0.	18	F4	23	96	
	DTTI0X_1		69	E9	79	47	
	FRCK0_0	16-bit free-run timer ch.0 external clock input pin	13	F1	18	91	
	FRCK0_1		70	D11	80	48	
	FRCK0_2		53	J10	63	31	
	IC00_0	16-bit input capture ch.0 input pin of Multi-function timer 0. ICxx describes channel number.	17	G2	22	95	
	IC00_1		65	F9	75	43	
	IC00_2		54	J8	64	32	
	IC01_0		16	G1	21	94	
	IC01_1		66	E11	76	44	
	IC01_2		55	H10	65	33	
	IC02_0		15	F3	20	93	
	IC02_1		67	E10	77	45	
	IC02_2		56	H9	66	34	
	IC03_0		14	F2	19	92	
	IC03_1		68	F8	78	46	
	IC03_2		57	H7	67	35	
	RTO00_0 (PPG00_0)		Wave form generator output pin of Multi-function timer 0.	19	G3	24	97
	RTO00_1 (PPG00_1)		This pin operates as PPG00 when it is used in PPG0 output modes.	-	-	86	-
	RTO01_0 (PPG00_0)		Wave form generator output pin of Multi-function timer 0.	20	H1	25	98
	RTO01_1 (PPG00_1)	This pin operates as PPG00 when it is used in PPG0 output modes.	-	-	85	-	
	RTO02_0 (PPG02_0)	Wave form generator output pin of Multi-function timer 0.	21	H2	26	99	
	RTO02_1 (PPG02_1)	This pin operates as PPG02 when it is used in PPG0 output modes.	-	-	84	-	
	RTO03_0 (PPG02_0)	Wave form generator output pin of Multi-function timer 0.	22	G4	27	100	
	RTO03_1 (PPG02_1)	This pin operates as PPG02 when it is used in PPG0 output modes.	-	-	83	-	
	RTO04_0 (PPG04_0)	Wave form generator output pin of Multi-function timer 0.	23	H3	28	1	
	RTO04_1 (PPG04_1)	This pin operates as PPG04 when it is used in PPG0 output modes.	-	-	82	-	
	RTO05_0 (PPG04_0)	Wave form generator output pin of Multi-function timer 0.	24	J2	29	2	
RTO05_1 (PPG04_1)	This pin operates as PPG04 when it is used in PPG0 output modes.	-	-	81	-		



Module	Pin name	Function	Pin No				
			LQFP-100	BGA-112	LQFP-120	QFP-100	
Multi-function Timer 1	DTTI1X_0	Input signal controlling wave form generator outputs RTO10 to RTO15 of Multi-function timer 1.	8	D5	8	86	
	DTTI1X_1		39	K6	44	17	
	FRCK1_0	16-bit free-run timer ch.1 external clock input pin	87	D7	102	65	
	FRCK1_1		44	J7	49	22	
	IC10_0	16-bit input capture ch.1 input pin of Multi-function timer 1. ICxx describes channel number.	88	A6	103	66	
	IC10_1		40	J6	45	18	
	IC11_0		89	B6	104	67	
	IC11_1		41	L7	46	19	
	IC12_0		90	C6	105	68	
	IC12_1		42	K7	47	20	
	IC13_0		91	A5	106	69	
	IC13_1		43	H6	48	21	
	RTO10_0 (PPG10_0)		Wave form generator output pin of Multi-function timer 1.	2	C1	2	80
	RTO10_1 (PPG10_1)		This pin operates as PPG10 when it is used in PPG1 output modes.	27	J4	32	5
	RTO11_0 (PPG10_0)	Wave form generator output pin of Multi-function timer 1.	3	C2	3	81	
	RTO11_1 (PPG10_1)	This pin operates as PPG10 when it is used in PPG1 output modes.	28	L5	33	6	
	RTO12_0 (PPG12_0)	Wave form generator output pin of Multi-function timer 1.	4	B3	4	82	
	RTO12_1 (PPG12_1)	This pin operates as PPG12 when it is used in PPG1 output modes.	29	K5	34	7	
	RTO13_0 (PPG12_0)	Wave form generator output pin of Multi-function timer 1.	5	D1	5	83	
	RTO13_1 (PPG12_1)	This pin operates as PPG12 when it is used in PPG1 output modes.	30	J5	35	8	
	RTO14_0 (PPG14_0)	Wave form generator output pin of Multi-function timer 1.	6	D2	6	84	
	RTO14_1 (PPG14_1)	This pin operates as PPG14 when it is used in PPG1 output modes.	31	H5	36	9	
	RTO15_0 (PPG14_0)	Wave form generator output pin of Multi-function timer 1.	7	D3	7	85	
	RTO15_1 (PPG14_1)	This pin operates as PPG14 when it is used in PPG1 output modes.	32	L6	37	10	

Module	Pin name	Function	Pin No				
			LQFP-100	BGA-112	LQFP-120	QFP-100	
Multi-function Timer 2	DTTI2X_0	Input signal controlling wave form generator outputs RTO20 to RTO25 of Multi-function timer 2.	92	B5	107	70	
	DTTI2X_1		92	B5	107	70	
	FRCK2_0	16-bit free-run timer ch.2 external clock input pin	87	D7	102	65	
	FRCK2_1		-	-	112	-	
	IC20_0	16-bit input capture ch.2 input pin of Multi-function timer 2. ICxx describes channel number.	88	A6	103	66	
	IC20_1		-	-	108	-	
	IC21_0		89	B6	104	67	
	IC21_1		-	-	109	-	
	IC22_0		90	C6	105	68	
	IC22_1		-	-	110	-	
	IC23_0		91	A5	106	69	
	IC23_1		-	-	111	-	
	RTO20_0 (PPG20_0)		Wave form generator output pin of Multi-function timer 2.	-	-	113	-
	RTO20_1 (PPG20_1)		This pin operates as PPG20 when it is used in PPG2 output modes.	86	C7	101	64
	RTO21_0 (PPG20_0)		Wave form generator output pin of Multi-function timer 2.	-	-	112	-
	RTO21_1 (PPG20_1)		This pin operates as PPG20 when it is used in PPG2 output modes.	87	D7	102	65
	RTO22_0 (PPG22_0)	Wave form generator output pin of Multi-function timer 2.	-	-	111	-	
	RTO22_1 (PPG22_1)	This pin operates as PPG22 when it is used in PPG2 output modes.	88	A6	103	66	
	RTO23_0 (PPG22_0)	Wave form generator output pin of Multi-function timer 2.	-	-	110	-	
	RTO23_1 (PPG22_1)	This pin operates as PPG22 when it is used in PPG2 output modes.	89	B6	104	67	
	RTO24_0 (PPG24_0)	Wave form generator output pin of Multi-function timer 2.	-	-	109	-	
	RTO24_1 (PPG24_1)	This pin operates as PPG24 when it is used in PPG2 output modes.	90	C6	105	68	
	RTO25_0 (PPG24_0)	Wave form generator output pin of Multi-function timer 2.	-	-	108	-	
	RTO25_1 (PPG24_1)	This pin operates as PPG24 when it is used in PPG2 output modes.	91	A5	106	69	

Module	Pin name	Function	Pin No				
			LQFP-100	BGA-112	LQFP-120	QFP-100	
Quadrature Position/ Revolution Counter 0	AIN0_0	QPRC ch.0 AIN input pin	9	E1	14	87	
	AIN0_1		40	J6	45	18	
	AIN0_2		2	C1	2	80	
	BIN0_0	BIN0_0	QPRC ch.0 BIN input pin	10	E2	15	88
		BIN0_1		41	L7	46	19
		BIN0_2		3	C2	3	81
	ZIN0_0	ZIN0_0	QPRC ch.0 ZIN input pin	11	E3	16	89
		ZIN0_1		42	K7	47	20
		ZIN0_2		4	B3	4	82
Quadrature Position/ Revolution Counter 1	AIN1_1	QPRC ch.1 AIN input pin	74	C10	89	52	
	AIN1_2		43	H6	48	21	
	BIN1_1	BIN1_1	QPRC ch.1 BIN input pin	73	C11	88	51
		BIN1_2		44	J7	49	22
	ZIN1_1	ZIN1_1	QPRC ch.1 ZIN input pin	72	E8	87	50
		ZIN1_2		45	K8	50	23
Quadrature Position/ Revolution Counter 2	AIN2_0	QPRC ch.2 AIN input pin	-	-	10	-	
	AIN2_1		83	D9	98	61	
	BIN2_0	BIN2_0	QPRC ch.2 BIN input pin	-	-	11	-
		BIN2_1		84	A7	99	62
	ZIN2_0	ZIN2_0	QPRC ch.2 ZIN input pin	-	-	12	-
		ZIN2_1		85	B7	100	63
Real-time clock	RTCCO_0	0.5 seconds pulse output pin of Real-time clock	92	B5	107	70	
	RTCCO_1		55	H10	65	33	
	RTCCO_2		19	G3	24	97	
	SUBOUT_0	SUBOUT_0	Sub clock output pin	92	B5	107	70
		SUBOUT_1		55	H10	65	33
		SUBOUT_2		19	G3	24	97

Module	Pin name	Function	Pin No			
			LQFP-100	BGA-112	LQFP-120	QFP-100
RESET	INITX	External Reset Input pin. A reset is valid when INITX="L".	38	K4	43	16
Mode	MD0	Mode 0 pin. During normal operation, MD0="L" must be input. During serial programming to Flash memory, MD0="H" must be input.	47	L8	57	25
	MD1	Mode 1 pin. During serial programming to Flash memory, MD1="L" must be input.	46	K9	56	24
POWER	VCC	Power supply Pin	1	B1	1	79
	VCC	Power supply Pin	26	J1	31	4
	VCC	Power supply Pin	35	K1	40	13
	VCC	Power supply Pin	51	K11	61	29
	VCC	Power supply Pin	76	A10	91	54
	VCC	Power supply Pin	97	A4	117	75
GND	VSS	GND Pin	-	B2	-	
	VSS	GND Pin	25	L1	30	3
	VSS	GND Pin	-	K2	-	
	VSS	GND Pin	-	J3	-	
	VSS	GND Pin	-	H4	-	
	VSS	GND Pin	34	L4	39	12
	VSS	GND Pin	50	L11	60	28
	VSS	GND Pin	-	K10	-	
	VSS	GND Pin	-	J9	-	
	VSS	GND Pin	-	H8	-	
	VSS	GND Pin	-	B10	-	
	VSS	GND Pin	-	C9	-	
	VSS	GND Pin	75	A11	90	53
	VSS	GND Pin	-	D8	-	
	VSS	GND Pin	-	D4	-	
	VSS	GND Pin	-	C3	-	
	VSS	GND Pin	100	A1	120	78
	CLOCK	X0	Main clock (oscillation) input pin	48	L9	58
X0A		Sub clock (oscillation) input pin	36	L3	41	14
X1		Main clock (oscillation) I/O pin	49	L10	59	27
X1A		Sub clock (oscillation) I/O pin	37	K3	42	15
CROUT_0		High-speed CR-osc clock output port	74	C10	89	52
CROUT_1			92	B5	107	70
ADC POWER	AVCC	A/D converter analog power pin	60	H11	70	38
	AVRH	A/D converter analog reference voltage input pin	61	F11	71	39
ADC GND	AVSS	A/D converter GND pin	62	G11	72	40
C pin	C	Power stabilization capacity pin	33	L2	38	11

■ I/O CIRCUIT TYPE

Type	Circuit	Remarks
A		<p>It is possible to select the main oscillation / GPIO function</p> <p>When the main oscillation is selected.</p> <ul style="list-style-type: none"> <li>• Oscillation feedback resistor : Approximately 1MΩ</li> <li>• With Standby mode control</li> </ul> <p>When the GPIO is selected.</p> <ul style="list-style-type: none"> <li>• CMOS level output.</li> <li>• CMOS level hysteresis input</li> <li>• With pull-up resistor control</li> <li>• With standby mode control</li> <li>• Pull-up resistor : Approximately 50kΩ</li> <li>• <math>I_{OH} = -4mA, I_{OL} = 4mA</math></li> </ul>
B		<ul style="list-style-type: none"> <li>• CMOS level hysteresis input</li> <li>• Pull-up resistor : Approximately 50kΩ</li> </ul>

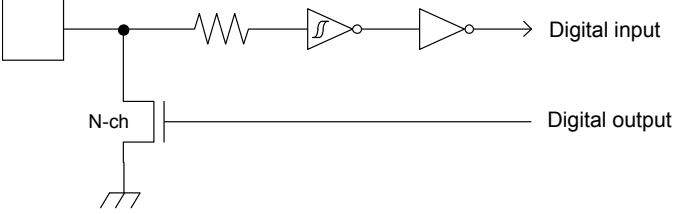
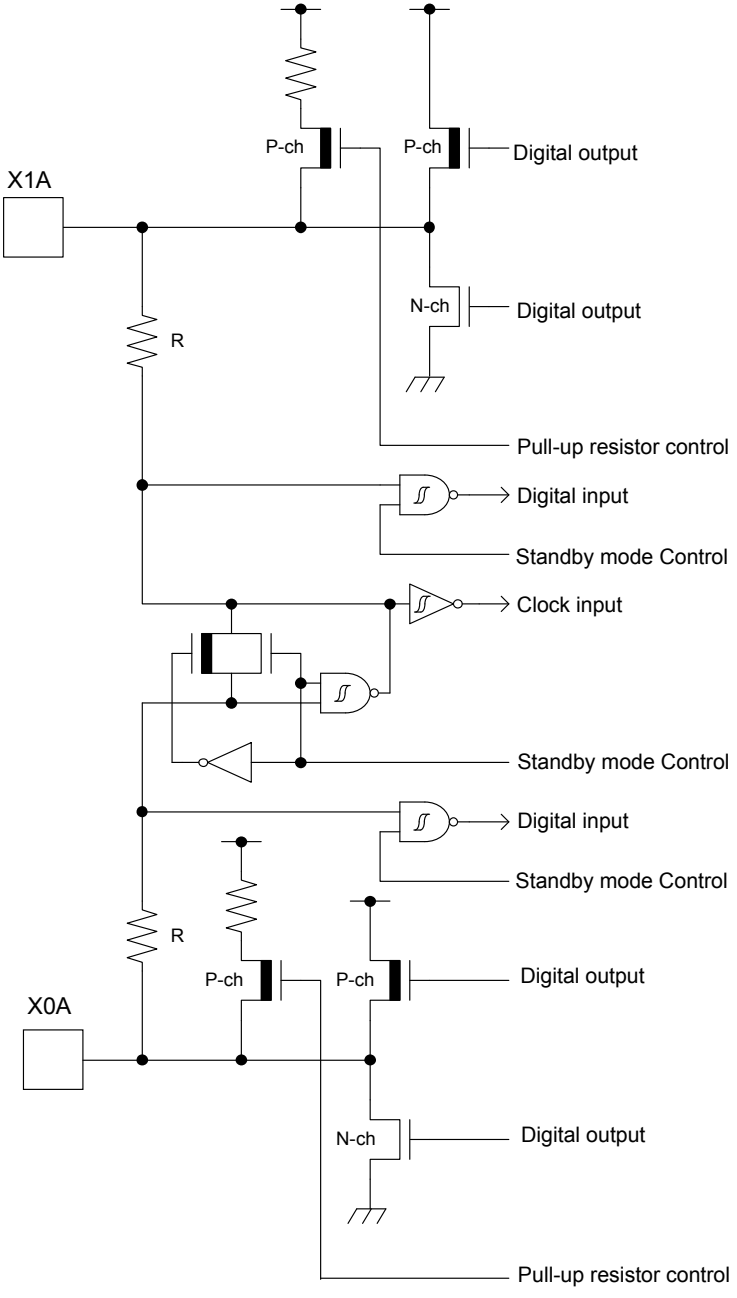
Type	Circuit	Remarks
C	 <p>The diagram shows a square symbol representing an open-drain output. A resistor is connected between this output and a digital input pin. An N-channel MOSFET is connected between the same output node and ground. The MOSFET's gate is also connected to the digital input pin. The output of the MOSFET is labeled 'Digital output'.</p>	<ul style="list-style-type: none"> <li>• Open drain output</li> <li>• CMOS level hysteresis input</li> </ul>
D	 <p>The diagram shows two digital outputs, X1A and X0A. Each output is connected to a pull-up resistor (R) and a digital input pin. The circuit includes several control signals: Pull-up resistor control, Standby mode Control, and Clock input. The outputs are connected to P-channel and N-channel MOSFETs. The N-channel MOSFETs are connected to ground, and the P-channel MOSFETs are connected to the output nodes. The circuit also includes logic gates (AND and OR) and inverters.</p>	<p>It is possible to select the sub oscillation / GPIO function</p> <p>When the sub oscillation is selected.</p> <ul style="list-style-type: none"> <li>• Oscillation feedback resistor : Approximately 5MΩ</li> <li>• With Standby mode control</li> </ul> <p>When the GPIO is selected.</p> <ul style="list-style-type: none"> <li>• CMOS level output.</li> <li>• CMOS level hysteresis input</li> <li>• With pull-up resistor control</li> <li>• With standby mode control</li> <li>• Pull-up resistor : Approximately 50kΩ</li> <li>• <math>I_{OH} = -4mA, I_{OL} = 4mA</math></li> </ul>

Type	Circuit	Remarks
E	<p>The circuit diagram for Type E shows a CMOS output stage. It consists of a P-channel MOSFET (P-ch) and an N-channel MOSFET (N-ch) connected in a common-emitter configuration. The gates of both MOSFETs are connected to a digital input signal. A pull-up resistor R is connected between the output node and the supply voltage. The output node is also connected to a digital output terminal. A standby mode control signal is connected to the gates of both MOSFETs through an AND gate. The gates of the MOSFETs are also connected to a pull-up resistor control signal.</p>	<ul style="list-style-type: none"> <li>• CMOS level output</li> <li>• CMOS level hysteresis input</li> <li>• With pull-up resistor control</li> <li>• With standby mode control</li> <li>• Pull-up resistor : Approximately 50kΩ</li> <li>• <math>I_{OH} = -4mA, I_{OL} = 4mA</math></li> </ul>
F	<p>The circuit diagram for Type F shows a CMOS output stage with an analog input. It consists of a P-channel MOSFET (P-ch) and an N-channel MOSFET (N-ch) connected in a common-emitter configuration. The gates of both MOSFETs are connected to a digital input signal. A pull-up resistor R is connected between the output node and the supply voltage. The output node is also connected to a digital output terminal. A standby mode control signal is connected to the gates of both MOSFETs through an AND gate. The gates of the MOSFETs are also connected to a pull-up resistor control signal. An analog input signal is connected to the gates of both MOSFETs through an inverter and a buffer. An input control signal is connected to the gates of both MOSFETs through a buffer.</p>	<ul style="list-style-type: none"> <li>• CMOS level output</li> <li>• CMOS level hysteresis input</li> <li>• With input control</li> <li>• Analog input</li> <li>• With pull-up resistor control</li> <li>• With standby mode control</li> <li>• Pull-up resistor : Approximately 50kΩ</li> <li>• <math>I_{OH} = -4mA, I_{OL} = 4mA</math></li> </ul>

Type	Circuit	Remarks
G	<p>The circuit diagram for Type G shows a CMOS output stage. A pull-up resistor R is connected to the output node. The output node is connected to a P-channel MOSFET (P-ch) and an N-channel MOSFET (N-ch). The P-channel MOSFET is controlled by a 'Pull-up resistor control' signal. The N-channel MOSFET is controlled by a 'Standby mode Control' signal. The output node is also connected to a 'Digital output' terminal. A 'Digital input' terminal is connected to the output node through an inverter. The 'Standby mode Control' signal is also connected to the inverter.</p>	<ul style="list-style-type: none"> <li>• CMOS level output</li> <li>• CMOS level hysteresis input</li> <li>• With pull-up resistor control</li> <li>• With standby mode control</li> <li>• Pull-up resistor : Approximately 50kΩ</li> <li>• <math>I_{OH} = -12\text{mA}</math>, <math>I_{OL} = 12\text{mA}</math></li> </ul>
H	<p>The circuit diagram for Type H shows a CMOS output stage. A pull-up resistor R is connected to the output node. The output node is connected to a P-channel MOSFET (P-ch) and an N-channel MOSFET (N-ch). The P-channel MOSFET is controlled by a 'Standby mode' signal. The N-channel MOSFET is controlled by a 'Standby mode' signal. The output node is also connected to a 'Digital output' terminal. A 'Digital input' terminal is connected to the output node through an inverter. The 'Standby mode' signal is also connected to the inverter.</p>	<ul style="list-style-type: none"> <li>• CMOS level output</li> <li>• CMOS level hysteresis input</li> <li>• With standby mode control</li> </ul>



Type	Circuit	Remarks
I	<p>The diagram shows a CMOS output stage. A pull-up resistor R is connected to the output node. The output node is connected to the gates of a P-channel MOSFET (P-ch) and an N-channel MOSFET (N-ch). The P-channel MOSFET's source is connected to VDD, and its drain is connected to the output node. The N-channel MOSFET's source is connected to ground, and its drain is connected to the output node. The gates of both MOSFETs are connected to a common control signal. This control signal is also connected to the input of an AND gate. The other input of the AND gate is connected to a Standby mode Control signal. The output of the AND gate is connected to the Digital input of a register. The output of the P-channel MOSFET is labeled Digital output.</p>	<ul style="list-style-type: none"> <li>• CMOS level output</li> <li>• CMOS level hysteresis input</li> <li>• With pull-up resistor control</li> <li>• 5V tolerant</li> <li>• With standby mode control</li> <li>• <math>I_{OH} = -4mA</math>, <math>I_{OL} = 4mA</math></li> <li>• Available to control of PZR registers.</li> </ul>
J	<p>The diagram shows a CMOS level hysteresis input circuit. It consists of a pull-up resistor connected to the input of a CMOS inverter. The output of the inverter is connected to the input of a second CMOS inverter. The output of the second inverter is labeled Mode input.</p>	<p>CMOS level hysteresis input</p>

## ■ HANDLING PRECAUTIONS

Any semiconductor devices have inherently a certain rate of failure. The possibility of failure is greatly affected by the conditions in which they are used (circuit conditions, environmental conditions, etc.). This page describes precautions that must be observed to minimize the chance of failure and to obtain higher reliability from your FUJITSU SEMICONDUCTOR semiconductor devices.

### 1. Precautions for Product Design

This section describes precautions when designing electronic equipment using semiconductor devices.

#### • Absolute Maximum Ratings

Semiconductor devices can be permanently damaged by application of stress (voltage, current, temperature, etc.) in excess of certain established limits, called absolute maximum ratings. Do not exceed these ratings.

#### • Recommended Operating Conditions

Recommended operating conditions are normal operating ranges for the semiconductor device. All the device's electrical characteristics are warranted when operated within these ranges.

Always use semiconductor devices within the recommended operating conditions. Operation outside these ranges may adversely affect reliability and could result in device failure.

No warranty is made with respect to uses, operating conditions, or combinations not represented on the data sheet. Users considering application outside the listed conditions are advised to contact their sales representative beforehand.

#### • Processing and Protection of Pins

These precautions must be followed when handling the pins which connect semiconductor devices to power supply and input/output functions.

##### (1) Preventing Over-Voltage and Over-Current Conditions

Exposure to voltage or current levels in excess of maximum ratings at any pin is likely to cause deterioration within the device, and in extreme cases leads to permanent damage of the device. Try to prevent such overvoltage or over-current conditions at the design stage.

##### (2) Protection of Output Pins

Shorting of output pins to supply pins or other output pins, or connection to large capacitance can cause large current flows. Such conditions if present for extended periods of time can damage the device.

Therefore, avoid this type of connection.

##### (3) Handling of Unused Input Pins

Unconnected input pins with very high impedance levels can adversely affect stability of operation.

Such pins should be connected through an appropriate resistance to a power supply pin or ground pin.

#### • Latch-up

Semiconductor devices are constructed by the formation of P-type and N-type areas on a substrate. When subjected to abnormally high voltages, internal parasitic PNPN junctions (called thyristor structures) may be formed, causing large current levels in excess of several hundred mA to flow continuously at the power supply pin. This condition is called latch-up.

**CAUTION:** The occurrence of latch-up not only causes loss of reliability in the semiconductor device, but can cause injury or damage from high heat, smoke or flame. To prevent this from happening, do the following:

(1) Be sure that voltages applied to pins do not exceed the absolute maximum ratings. This should include attention to abnormal noise, surge levels, etc.

(2) Be sure that abnormal current flows do not occur during the power-on sequence.

Code: DS00-00004-1Ea

- Observance of Safety Regulations and Standards

Most countries in the world have established standards and regulations regarding safety, protection from electromagnetic interference, etc. Customers are requested to observe applicable regulations and standards in the design of products.

- Fail-Safe Design

Any semiconductor devices have inherently a certain rate of failure. You must protect against injury, damage or loss from such failures by incorporating safety design measures into your facility and equipment such as redundancy, fire protection, and prevention of over-current levels and other abnormal operating conditions.

- Precautions Related to Usage of Devices

FUJITSU SEMICONDUCTOR semiconductor devices are intended for use in standard applications (computers, office automation and other office equipment, industrial, communications, and measurement equipment, personal or household devices, etc.).

**CAUTION:** Customers considering the use of our products in special applications where failure or abnormal operation may directly affect human lives or cause physical injury or property damage, or where extremely high levels of reliability are demanded (such as aerospace systems, atomic energy controls, sea floor repeaters, vehicle operating controls, medical devices for life support, etc.) are requested to consult with sales representatives before such use. The company will not be responsible for damages arising from such use without prior approval.

## 2. Precautions for Package Mounting

Package mounting may be either lead insertion type or surface mount type. In either case, for heat resistance during soldering, you should only mount under FUJITSU SEMICONDUCTOR's recommended conditions. For detailed information about mount conditions, contact your sales representative.

- Lead Insertion Type

Mounting of lead insertion type packages onto printed circuit boards may be done by two methods: direct soldering on the board, or mounting by using a socket.

Direct mounting onto boards normally involves processes for inserting leads into through-holes on the board and using the flow soldering (wave soldering) method of applying liquid solder. In this case, the soldering process usually causes leads to be subjected to thermal stress in excess of the absolute ratings for storage temperature. Mounting processes should conform to FUJITSU SEMICONDUCTOR recommended mounting conditions.

If socket mounting is used, differences in surface treatment of the socket contacts and IC lead surfaces can lead to contact deterioration after long periods. For this reason it is recommended that the surface treatment of socket contacts and IC leads be verified before mounting.

- Surface Mount Type

Surface mount packaging has longer and thinner leads than lead-insertion packaging, and therefore leads are more easily deformed or bent. The use of packages with higher pin counts and narrower pin pitch results in increased susceptibility to open connections caused by deformed pins, or shorting due to solder bridges.

You must use appropriate mounting techniques. FUJITSU SEMICONDUCTOR recommends the solder reflow method, and has established a ranking of mounting conditions for each product. Users are advised to mount packages in accordance with FUJITSU SEMICONDUCTOR ranking of recommended conditions.

- Lead-Free Packaging

CAUTION: When ball grid array (BGA) packages with Sn-Ag-Cu balls are mounted using Sn-Pb eutectic soldering, junction strength may be reduced under some conditions of use.

- Storage of Semiconductor Devices

Because plastic chip packages are formed from plastic resins, exposure to natural environmental conditions will cause absorption of moisture. During mounting, the application of heat to a package that has absorbed moisture can cause surfaces to peel, reducing moisture resistance and causing packages to crack. To prevent, do the following:

- (1) Avoid exposure to rapid temperature changes, which cause moisture to condense inside the product. Store products in locations where temperature changes are slight.
- (2) Use dry boxes for product storage. Products should be stored below 70% relative humidity, and at temperatures between 5°C and 30°C. When you open Dry Package that recommends humidity 40% to 70% relative humidity.
- (3) When necessary, FUJITSU SEMICONDUCTOR packages semiconductor devices in highly moisture-resistant aluminum laminate bags, with a silica gel desiccant. Devices should be sealed in their aluminum laminate bags for storage.
- (4) Avoid storing packages where they are exposed to corrosive gases or high levels of dust.

- Baking

Packages that have absorbed moisture may be de-moisturized by baking (heat drying). Follow the FUJITSU SEMICONDUCTOR recommended conditions for baking.

Condition: 125°C/24 h

- Static Electricity

Because semiconductor devices are particularly susceptible to damage by static electricity, you must take the following precautions:

- (1) Maintain relative humidity in the working environment between 40% and 70%. Use of an apparatus for ion generation may be needed to remove electricity.
- (2) Electrically ground all conveyors, solder vessels, soldering irons and peripheral equipment.
- (3) Eliminate static body electricity by the use of rings or bracelets connected to ground through high resistance (on the level of 1 MΩ). Wearing of conductive clothing and shoes, use of conductive floor mats and other measures to minimize shock loads is recommended.
- (4) Ground all fixtures and instruments, or protect with anti-static measures.
- (5) Avoid the use of styrofoam or other highly static-prone materials for storage of completed board assemblies.

### 3. Precautions for Use Environment

Reliability of semiconductor devices depends on ambient temperature and other conditions as described above.

For reliable performance, do the following:

(1) Humidity

Prolonged use in high humidity can lead to leakage in devices as well as printed circuit boards. If high humidity levels are anticipated, consider anti-humidity processing.

(2) Discharge of Static Electricity

When high-voltage charges exist close to semiconductor devices, discharges can cause abnormal operation. In such cases, use anti-static measures or processing to prevent discharges.

(3) Corrosive Gases, Dust, or Oil

Exposure to corrosive gases or contact with dust or oil may lead to chemical reactions that will adversely affect the device. If you use devices in such conditions, consider ways to prevent such exposure or to protect the devices.

(4) Radiation, Including Cosmic Radiation

Most devices are not designed for environments involving exposure to radiation or cosmic radiation. Users should provide shielding as appropriate.

(5) Smoke, Flame

CAUTION: Plastic molded devices are flammable, and therefore should not be used near combustible substances. If devices begin to smoke or burn, there is danger of the release of toxic gases. Customers considering the use of FUJITSU SEMICONDUCTOR products in other special environmental conditions should consult with sales representatives.

Please check the latest handling precautions at the following URL.

<http://edevice.fujitsu.com/fj/handling-e.pdf>

## ■ HANDLING DEVICES

### ● Power supply pins

In products with multiple VCC and VSS pins, respective pins at the same potential are interconnected within the device in order to prevent malfunctions such as latch-up. However, all of these pins should be connected externally to the power supply or ground lines in order to reduce electromagnetic emission levels, to prevent abnormal operation of strobe signals caused by the rise in the ground level, and to conform to the total output current rating.

Moreover, connect the current supply source with each POWER pins and GND pins of this device at low impedance. It is also advisable that a ceramic capacitor of approximately 0.1  $\mu\text{F}$  be connected as a bypass capacitor between VCC and VSS near this device.

### ● Crystal oscillator circuit

Noise near the X0/X1 and X0A/X1A pins may cause the device to malfunction. Design the printed circuit board so that X0/X1, X0A/X1A pins, the crystal oscillator (or ceramic oscillator), and the bypass capacitor to ground are located as close to the device as possible.

It is strongly recommended that the PC board artwork be designed such that the X0/X1 and X0A/X1A pins are surrounded by ground plane as this is expected to produce stable operation.

### ● Using an external clock

When using an external clock, the clock signal should be input to the X0, X0A pin only and the X1, X1A pin should be kept open.

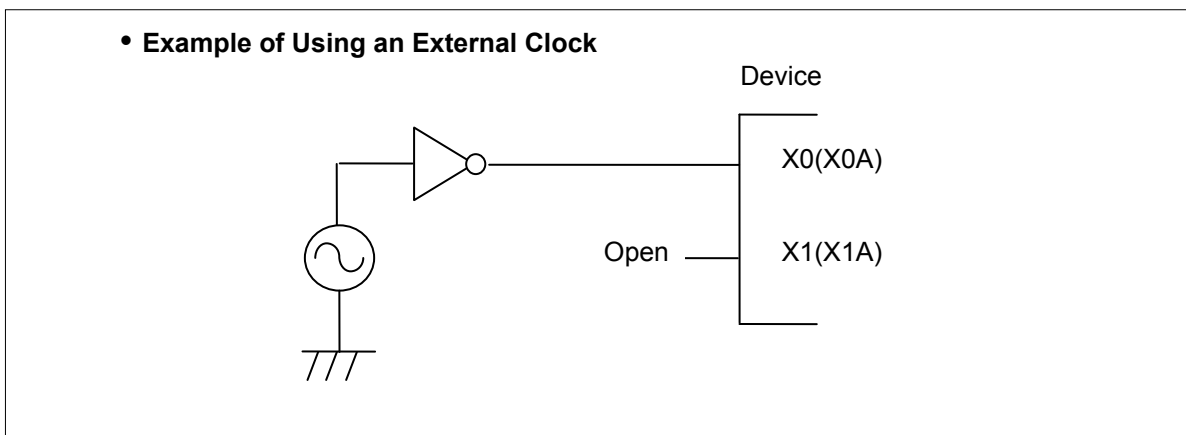

### ● Handling when using Multi function serial pin as I<sup>2</sup>C pin

If it is using multi function serial pin as I<sup>2</sup>C pins, P-ch transistor of digital output is always disable. However, I<sup>2</sup>C pins need to keep the electrical characteristic like other pins and not to connect to external I<sup>2</sup>C bus system with power OFF.

- C Pin

As this series includes an internal regulator, always connect a bypass capacitor of approximately 4.7  $\mu\text{F}$  to the C pin for use by the regulator.

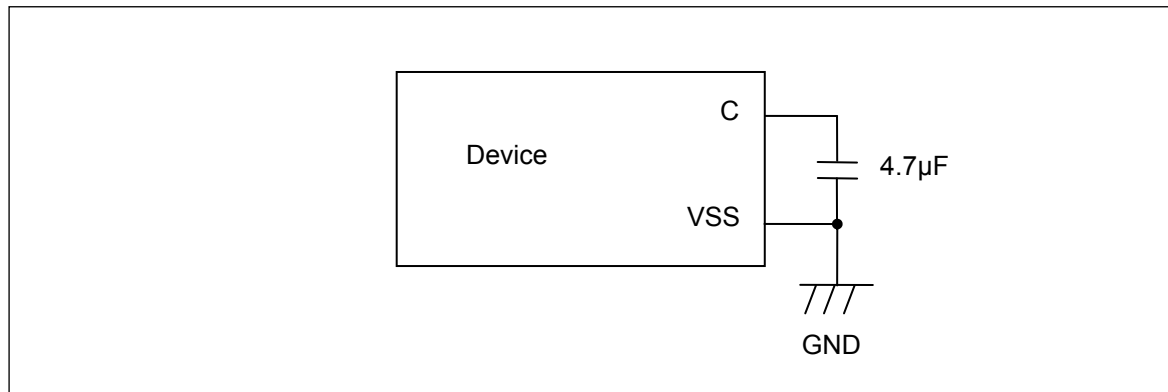

- Mode pins (MD0)

Connect the MD pin (MD0) directly to VCC or VSS pins. Design the printed circuit board such that the pull-up/down resistance stays low, as well as the distance between the mode pins and VCC pins or VSS pins is as short as possible and the connection impedance is low, when the pins are pulled-up/down such as for switching the pin level and rewriting the Flash memory data. It is because of preventing the device erroneously switching to test mode due to noise.

- Notes on power-on

Turn power on/off in the following order or at the same time.

If not using the A/D converter, connect AVCC = VCC and AVSS = VSS.

Turning on : VCC → AVCC → AVRH

Turning off : AVRH → AVCC → VCC

- Serial Communication

There is a possibility to receive wrong data due to the noise or other causes on the serial communication. Therefore, design a printed circuit board so as to avoid noise.

Consider the case of receiving wrong data due to noise, perform error detection such as by applying a checksum of data at the end. If an error is detected, retransmit the data.

- Differences in features among the products with different memory sizes and between Flash products and MASK products

The electric characteristics including power consumption, ESD, latch-up, noise characteristics, and oscillation characteristics among the products with different memory sizes and between Flash products and MASK products are different because chip layout and memory structures are different.

If you are switching to use a different product of the same series, please make sure to evaluate the electric characteristics.

- Pull-Up function of 5V tolerant I/O

Please do not input the signal more than VCC voltage at the time of Pull-Up function use of 5V tolerant I/O.

## ■ BLOCK DIAGRAM

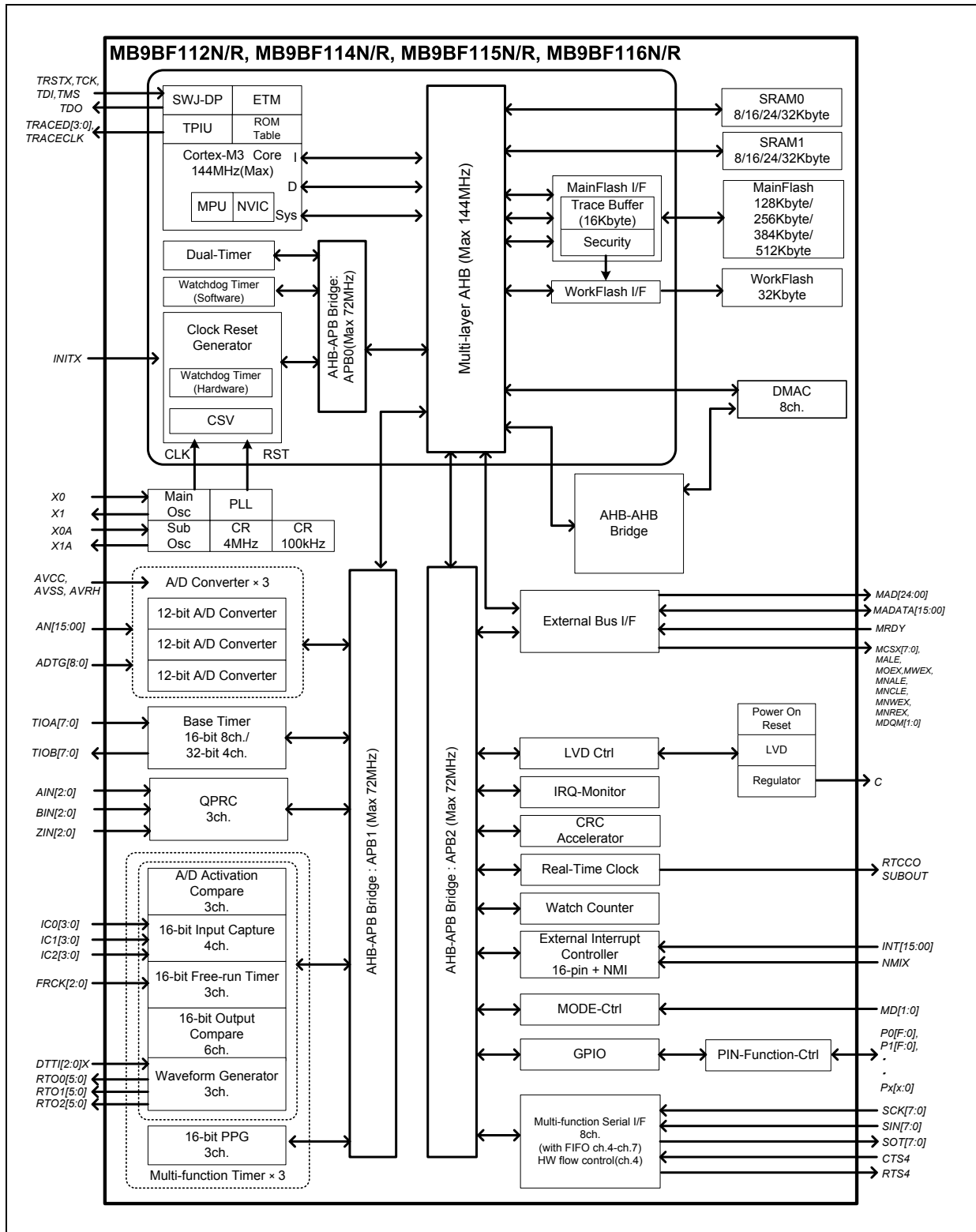

## ■ MEMORY SIZE

See "■PRODUCT LINEUP" of " • Memory size" to confirm the memory size.



■ MEMORY MAP

● Memory Map (1)

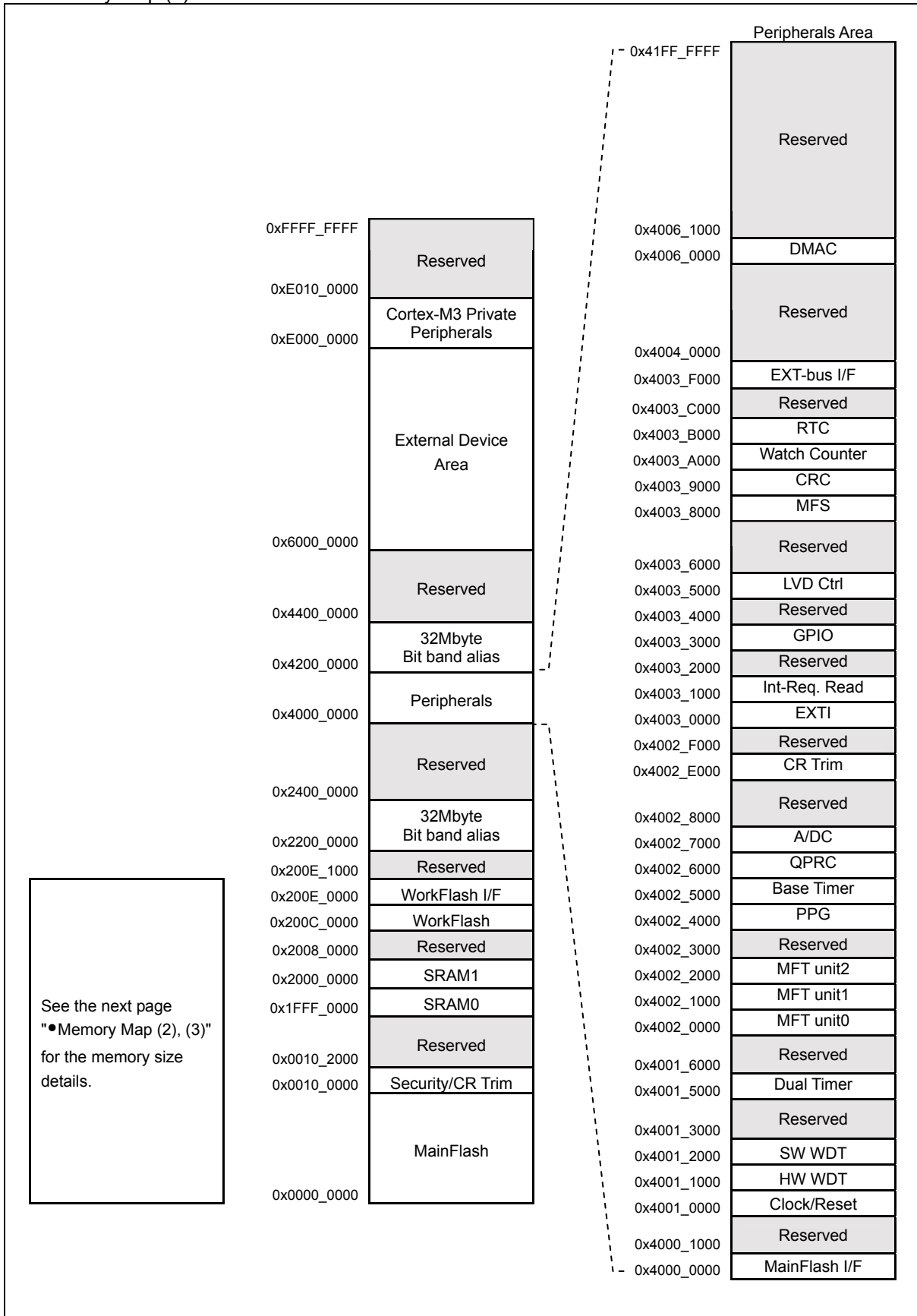

● Memory Map (2)

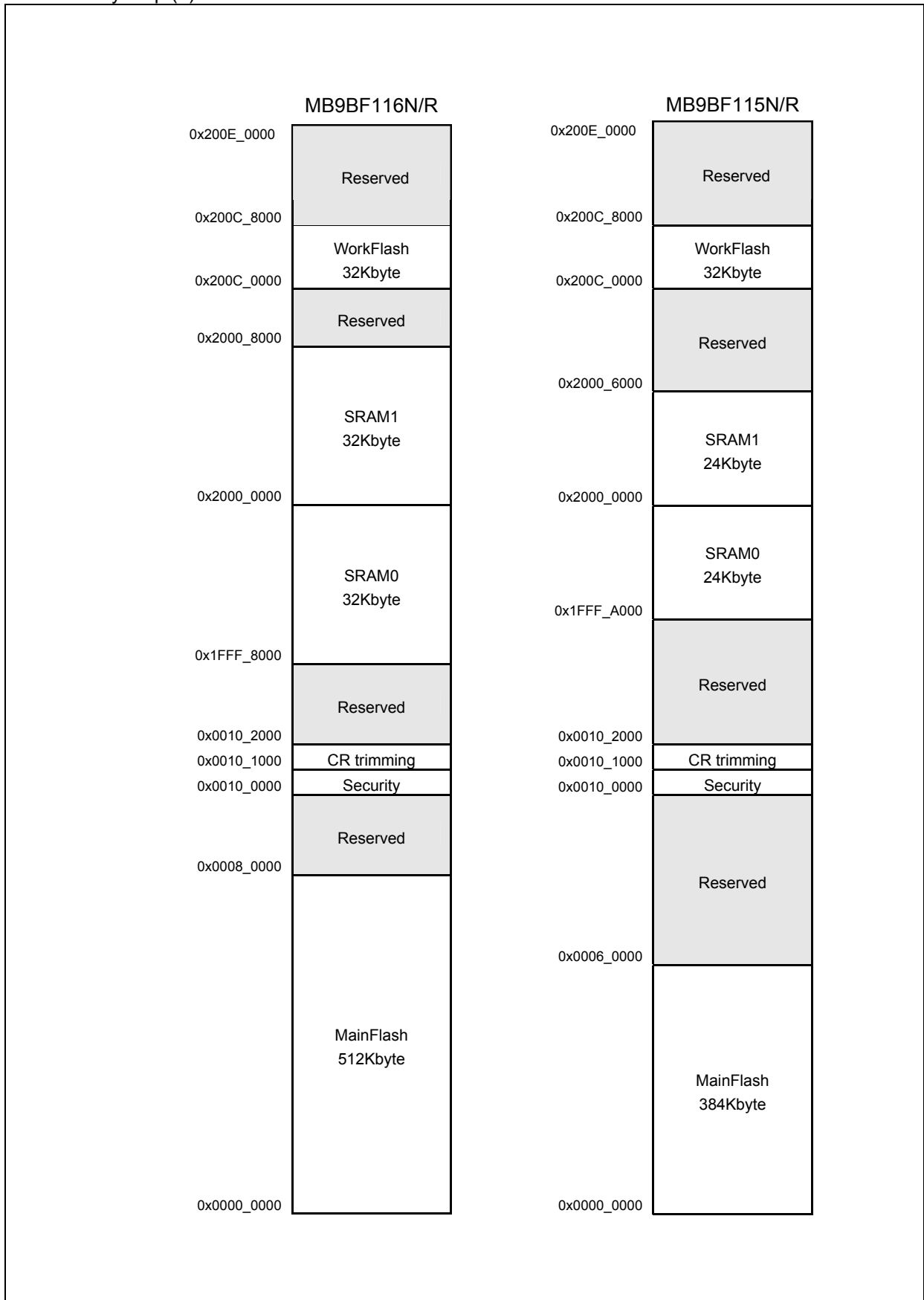

● Memory Map (3)

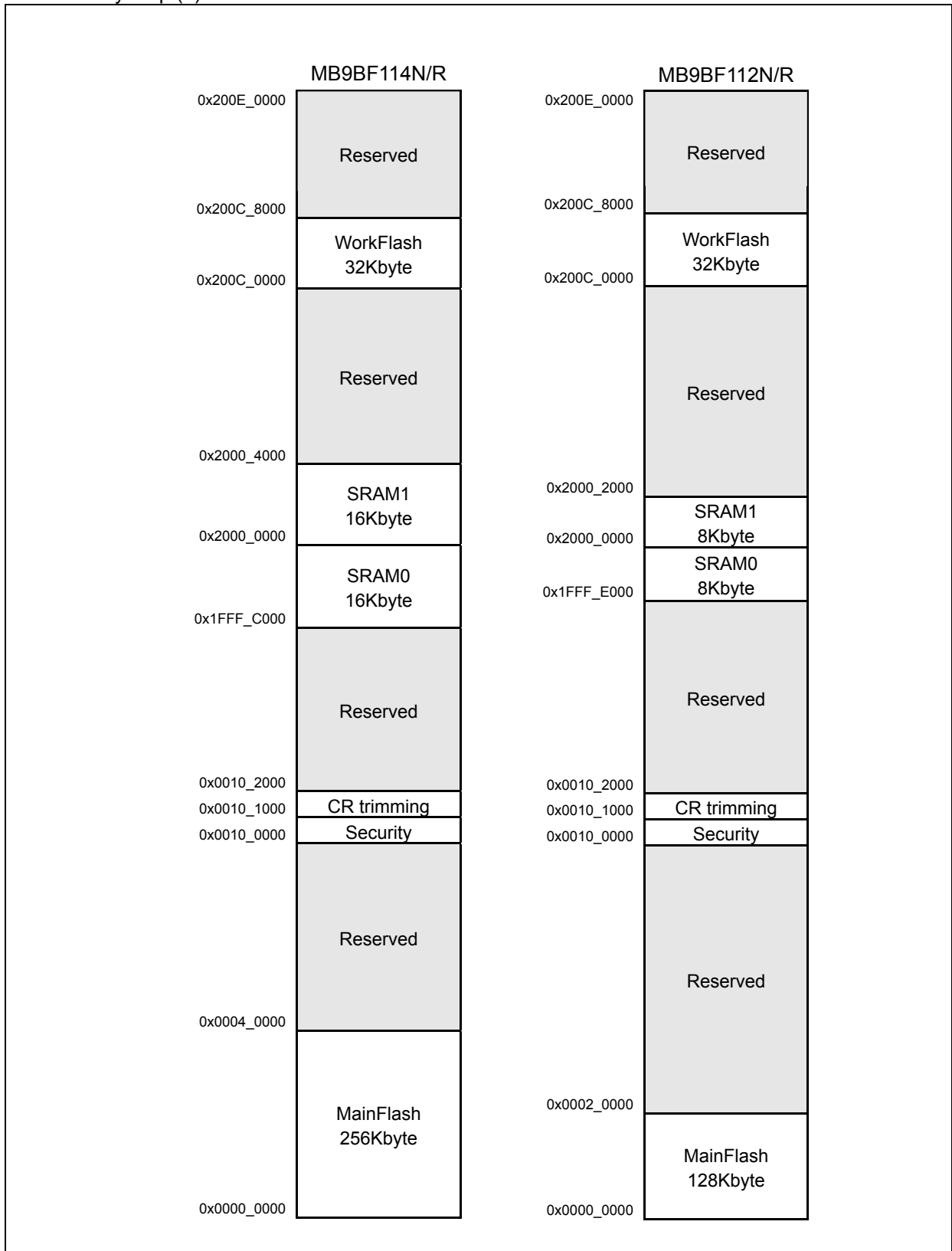

● Peripheral Address Map

Start address	End address	Bus	Peripherals
0x4000_0000	0x4000_0FFF	AHB	MainFlash I/F register
0x4000_1000	0x4000_FFFF		Reserved
0x4001_0000	0x4001_0FFF	APB0	Clock/Reset Control
0x4001_1000	0x4001_1FFF		Hardware Watchdog timer
0x4001_2000	0x4001_2FFF		Software Watchdog timer
0x4001_3000	0x4001_4FFF		Reserved
0x4001_5000	0x4001_5FFF		Dual-Timer
0x4001_6000	0x4001_FFFF		Reserved
0x4002_0000	0x4002_0FFF		APB1
0x4002_1000	0x4002_1FFF	Multi-function timer unit1	
0x4002_2000	0x4002_3FFF	Multi-function timer unit2	
0x4002_4000	0x4002_4FFF	PPG	
0x4002_5000	0x4002_5FFF	Base Timer	
0x4002_6000	0x4002_6FFF	Quadrature Position/Revolution Counter	
0x4002_7000	0x4002_7FFF	A/D Converter	
0x4002_8000	0x4002_DFFF	Reserved	
0x4002_E000	0x4002_EFFF	Internal CR trimming	
0x4002_F000	0x4002_FFFF	Reserved	
0x4003_0000	0x4003_0FFF	APB2	
0x4003_1000	0x4003_1FFF		Interrupt Request Batch-Read Function
0x4003_2000	0x4003_2FFF		Reserved
0x4003_3000	0x4003_3FFF		GPIO
0x4003_4000	0x4003_4FFF		Reserved
0x4003_5000	0x4003_5FFF		Low-Voltage Detector
0x4003_6000	0x4003_6FFF		Reserved
0x4003_7000	0x4003_7FFF		CAN prescaler
0x4003_8000	0x4003_8FFF		Multi-function serial Interface
0x4003_9000	0x4003_9FFF		CRC
0x4003_A000	0x4003_AFFF		Watch Counter
0x4003_B000	0x4003_BFFF		Real-time clock
0x4003_C000	0x4003_EFFF		Reserved
0x4003_F000	0x4003_FFFF		External Memory interface
0x4004_0000	0x4005_FFFF		AHB
0x4006_0000	0x4006_0FFF	DMAC register	
0x4006_1000	0x41FF_FFFF	Reserved	
0x200E_0000	0x200E_FFFF	WorkFlash I/F register	

## ■ PIN STATUS IN EACH CPU STATE

The terms used for pin status have the following meanings.

- INITX=0  
This is the period when the INITX pin is the "L" level.
- INITX=1  
This is the period when the INITX pin is the "H" level.
- SPL=0  
This is the status that standby pin level setting bit (SPL) in standby mode control register (STB\_CTL) is set to "0".
- SPL=1  
This is the status that standby pin level setting bit (SPL) in standby mode control register (STB\_CTL) is set to "1".
- Input enabled  
Indicates that the input function can be used.
- Internal input fixed at "0"  
This is the status that the input function cannot be used. Internal input is fixed at "L".
- Hi-Z  
Indicates that the output drive transistor is disabled and the pin is put in the Hi-Z state.
- Setting disabled  
Indicates that the setting is disabled.
- Maintain previous state  
Maintains the state that was immediately prior to entering the current mode.  
If a built-in peripheral function is operating, the output follows the peripheral function.  
If the pin is being used as a port, that output is maintained.
- Analog input is enabled  
Indicates that the analog input is enabled.
- Trace output  
Indicates that the trace function can be used.

● List of Pin Status

Pin status type	Function group	Power-on reset or low-voltage detection state	INITX input state	Device internal reset state	Run mode or sleep mode state	Timer mode or sleep mode state	
		Power supply unstable	Power supply stable		Power supply stable	Power supply stable	
		-	INITX=0	INITX=1	INITX=1	INITX=1	
		-	-	-	-	SPL=0	SPL=1
A	GPIO selected	Setting disabled	Setting disabled	Setting disabled	Maintain previous state	Maintain previous state	Hi-Z/ Internal input fixed at "0"
	Main crystal oscillator input pin	Input enabled	Input enabled	Input enabled	Input enabled	Input enabled	Input enabled
B	GPIO selected	Setting disabled	Setting disabled	Setting disabled	Maintain previous state	Maintain previous state	Hi-Z/ Internal input fixed at "0"
	Main crystal oscillator output pin	Hi-Z/ Internal input fixed at "0"/ or Input enable	Hi-Z/ Internal input fixed at "0"	Hi-Z/ Internal input fixed at "0"	Maintain previous state	Maintain previous state/ Hi-Z at oscillation stop*1/ Internal input fixed at "0"	Maintain previous state/ Hi-Z at oscillation stop*1/ Internal input fixed at "0"
C	INITX input pin	Pull-up/ Input enabled	Pull-up/ Input enabled	Pull-up/ Input enabled	Pull-up/ Input enabled	Pull-up/ Input enabled	Pull-up/ Input enabled
D	Mode input pin	Input enabled	Input enabled	Input enabled	Input enabled	Input enabled	Input enabled
E	JTAG selected	Hi-Z	Pull-up/ Input enabled	Pull-up/ Input enabled	Maintain previous state	Maintain previous state	Maintain previous state
	GPIO selected	Setting disabled	Setting disabled	Setting disabled			Hi-Z/ Internal input fixed at "0"
F	Trace selected	Setting disabled	Setting disabled	Setting disabled	Maintain previous state	Maintain previous state	Trace output
	External interrupt enabled selected						Maintain previous state
	GPIO selected, or other than above resource selected	Hi-Z	Hi-Z/ Input enabled	Hi-Z/ Input enabled			Hi-Z/ Internal input fixed at "0"

Pin status type	Function group	Power-on reset or low-voltage detection state	INITX input state	Device internal reset state	Run mode or sleep mode state	Timer mode or sleep mode state	
		Power supply unstable	Power supply stable		Power supply stable	Power supply stable	
		-	INITX=0	INITX=1	INITX=1	INITX=1	
		-	-	-	-	SPL=0	SPL=1
G	Trace selected	Setting disabled	Setting disabled	Setting disabled	Maintain previous state	Maintain previous state	Trace output
	GPIO selected, or other than above resource selected	Hi-Z	Hi-Z/ Input enabled	Hi-Z/ Input enabled			Hi-Z/ Internal input fixed at "0"
H	External interrupt enabled selected	Setting disabled	Setting disabled	Setting disabled	Maintain previous state	Maintain previous state	Maintain previous state
	GPIO selected, or other than above resource selected	Hi-Z	Hi-Z/ Input enabled	Hi-Z/ Input enabled			Hi-Z/ Internal input fixed at "0"
I	GPIO selected, resource selected	Hi-Z	Hi-Z/ Input enabled	Hi-Z/ Input enabled	Maintain previous state	Maintain previous state	Hi-Z/ Internal input fixed at "0"
J	NMIX selected	Setting disabled	Setting disabled	Setting disabled	Maintain previous state	Maintain previous state	Maintain previous state
	GPIO selected, or other than above resource selected	Hi-Z	Hi-Z/ Input enabled	Hi-Z/ Input enabled			Hi-Z/ Internal input fixed at "0"

Pin status type	Function group	Power-on reset or low-voltage detection state	INITX input state	Device internal reset state	Run mode or sleep mode state	Timer mode or sleep mode state	
		Power supply unstable	Power supply stable		Power supply stable	Power supply stable	
		-	INITX=0	INITX=1	INITX=1	INITX=1	
		-	-	-	-	SPL=0	SPL=1
K	Analog input selected	Hi-Z	Hi-Z/ Internal input fixed at "0"/ Analog input enabled	Hi-Z/ Internal input fixed at "0"/ Analog input enabled	Hi-Z/ Internal input fixed at "0"/ Analog input enabled	Hi-Z/ Internal input fixed at "0"/ Analog input enabled	Hi-Z/ Internal input fixed at "0"/ Analog input enabled
	GPIO selected, or other than above resource selected	Setting disabled	Setting disabled	Setting disabled	Maintain previous state	Maintain previous state	Hi-Z/ Internal input fixed at "0"
L	External interrupt enabled selected	Setting disabled	Setting disabled	Setting disabled	Maintain previous state	Maintain previous state	Maintain previous state
	Analog input selected	Hi-Z	Hi-Z/ Internal input fixed at "0"/ Analog input enabled	Hi-Z/ Internal input fixed at "0"/ Analog input enabled	Hi-Z/ Internal input fixed at "0"/ Analog input enabled	Hi-Z/ Internal input fixed at "0"/ Analog input enabled	Hi-Z/ Internal input fixed at "0"/ Analog input enabled
	GPIO selected, or other than above resource selected	Setting disabled	Setting disabled	Setting disabled	Maintain previous state	Maintain previous state	Hi-Z/ Internal input fixed at "0"
M	GPIO selected	Setting disabled	Setting disabled	Setting disabled	Maintain previous state	Maintain previous state	Hi-Z/ Internal input fixed at "0"
	Sub crystal oscillator input pin	Input enabled	Input enabled	Input enabled	Input enabled	Input enabled	Input enabled



Pin status type	Function group	Power-on reset or low-voltage detection state	INITX input state	Device internal reset state	Run mode or sleep mode state	Timer mode or sleep mode state	
		Power supply unstable	Power supply stable		Power supply stable	Power supply stable	
		-	INITX=0	INITX=1	INITX=1	INITX=1	
		-	-	-	-	SPL=0	SPL=1
N	GPIO selected	Setting disabled	Setting disabled	Setting disabled	Maintain previous state	Maintain previous state	Hi-Z/ Internal input fixed at "0"
	Sub crystal oscillator output pin	Hi-Z/ Internal input fixed at "0"/ or Input enable	Hi-Z/ Internal input fixed at "0"	Hi-Z/ Internal input fixed at "0"	Maintain previous state	Maintain previous state/ Hi-Z at oscillation stop*2/ Internal input fixed at "0"	Maintain previous state/ Hi-Z at oscillation stop*2/ Internal input fixed at "0"
O	GPIO selected	Hi-Z	Hi-Z/ Input enabled	Hi-Z/ Input enabled	Maintain previous state	Maintain previous state	Hi-Z/ Internal input fixed at "0"
P	Mode input pin	Input enabled	Input enabled	Input enabled	Input enabled	Input enabled	Input enabled
	GPIO selected	Setting disabled	Setting disabled	Setting disabled	Maintain previous state	Maintain previous state	Hi-Z/ Input enabled

\*1 : Oscillation is stopped at Sub timer mode, Low-speed CR timer mode, and STOP mode.

\*2 : Oscillation is stopped at STOP mode.

## ■ ELECTRICAL CHARACTERISTICS

### 1. Absolute Maximum Ratings

Parameter	Symbol	Rating		Unit	Remarks
		Min	Max		
Power supply voltage*1, *2	V <sub>CC</sub>	V <sub>SS</sub> - 0.5	V <sub>SS</sub> + 6.5	V	
Analog power supply voltage*1, *3	AV <sub>CC</sub>	V <sub>SS</sub> - 0.5	V <sub>SS</sub> + 6.5	V	
Analog reference voltage*1, *3	AV <sub>RH</sub>	V <sub>SS</sub> - 0.5	V <sub>SS</sub> + 6.5	V	
Input voltage*1	V <sub>I</sub>	V <sub>SS</sub> - 0.5	V <sub>CC</sub> + 0.5 (≤ 6.5V)	V	
		V <sub>SS</sub> - 0.5	V <sub>SS</sub> + 6.5	V	5V tolerant
Analog pin input voltage*1	V <sub>IA</sub>	V <sub>SS</sub> - 0.5	AV <sub>CC</sub> + 0.5 (≤ 6.5V)	V	
Output voltage*1	V <sub>O</sub>	V <sub>SS</sub> - 0.5	V <sub>CC</sub> + 0.5 (≤ 6.5V)	V	
"L" level maximum output current*4	I <sub>OL</sub>	-	10	mA	4mA type
			20	mA	12mA type
"L" level average output current*6	I <sub>OLAV</sub>	-	4	mA	4mA type
			12	mA	12mA type
"L" level total maximum output current	∑I <sub>OL</sub>	-	100	mA	
"L" level total average output current*6	∑I <sub>OLAV</sub>	-	50	mA	
"H" level maximum output current*4	I <sub>OH</sub>	-	- 10	mA	4mA type
			- 20	mA	12mA type
"H" level average output current*5	I <sub>OHAV</sub>	-	- 4	mA	4mA type
			- 12	mA	12mA type
"H" level total maximum output current	∑I <sub>OH</sub>	-	- 100	mA	
"H" level total average output current*6	∑I <sub>OHAV</sub>	-	- 50	mA	
Power consumption	P <sub>D</sub>	-	1000	mW	
Storage temperature	T <sub>STG</sub>	- 55	+ 150	°C	

\*1 : These parameters are based on the condition that V<sub>SS</sub> = AV<sub>SS</sub> = 0.0V.

\*2 : V<sub>CC</sub> must not drop below V<sub>SS</sub> - 0.5V.

\*3 : Ensure that the voltage does not to exceed V<sub>CC</sub> + 0.5 V, for example, when the power is turned on.

\*4 : The maximum output current is the peak value for a single pin.

\*5 : The average output is the average current for a single pin over a period of 100 ms.

\*6 : The total average output current is the average current for all pins over a period of 100 ms.

### <WARNING>

Semiconductor devices can be permanently damaged by application of stress (voltage, current, temperature, etc.) in excess of absolute maximum ratings. Do not exceed these ratings.

## 2. Recommended Operating Conditions

(V<sub>ss</sub> = AV<sub>ss</sub> = 0.0V)

Parameter	Symbol	Conditions	Value		Unit	Remarks	
			Min	Max			
Power supply voltage	V <sub>cc</sub>	-	2.7	5.5	V		
Analog power supply voltage	AV <sub>cc</sub>	-	2.7	5.5	V	AV <sub>cc</sub> = V <sub>cc</sub>	
Analog reference voltage	AV <sub>RH</sub>	-	AV <sub>ss</sub>	AV <sub>cc</sub>	V		
Operating temperature	FPT-100P-M20/M23 FPT-120P-M21/M37	T <sub>a</sub>	When mounted on four-layer PCB	- 40	+ 85	°C	
	FTP-100P-M36 BGA-112P-M04	T <sub>a</sub>	-	- 40	+ 85	°C	

**<WARNING>**

The recommended operating conditions are required in order to ensure the normal operation of the semiconductor device. All of the device's electrical characteristics are warranted when the device is operated within these ranges.

Always use semiconductor devices within their recommended operating condition ranges. Operation outside these ranges may adversely affect reliability and could result in device failure. No warranty is made with respect to uses, operating conditions, or combinations not represented on the data sheet. Users considering application outside the listed conditions are advised to contact their representatives beforehand.

### 3. DC Characteristics

#### (1) Current Rating

(V<sub>cc</sub> = AV<sub>cc</sub> = 2.7V to 5.5V, V<sub>ss</sub> = AV<sub>ss</sub> = 0V, T<sub>a</sub> = - 40°C to + 85°C)

Parameter	Symbol	Pin name	Conditions	Value			Unit	Remarks
				Min	Typ	Max		
Power supply current	I <sub>cc</sub>	VCC	Normal operation (PLL)	-	95	TBD	mA	CPU : 144MHz, Peripheral : 72MHz, Flash 2Wait TraceBuffer : ON FRWTR.RWT = 10 FSYNDN.SD = 000 FBFCR.BE = 1 *1, *3
				-	60	TBD	mA	CPU : 72MHz, Peripheral : 72MHz, Flash 0Wait TraceBuffer : OFF FRWTR.RWT = 00 FSYNDN.SD = 000 FBFCR.BE = 0 *1
			Normal operation (high-speed internal CR)	-	6	TBD	mA	CPU/ Peripheral : 4MHz* <sup>2</sup> Flash 0Wait FRWTR.RWT = 00 FSYNDN.SD = 000 *1
			Normal operation (sub oscillation)	-	1.3	TBD	mA	CPU/ Peripheral : 32kHz Flash 0Wait FRWTR.RWT = 00 FSYNDN.SD = 000 *1
			Normal operation (low-speed internal CR)	-	1.3	TBD	mA	CPU/ Peripheral : 100kHz Flash 0Wait FRWTR.RWT = 00 FSYNDN.SD = 000 *1
	I <sub>ccs</sub>		SLEEP operation (PLL)	-	28	TBD	mA	Peripheral : 72MHz *1
			SLEEP operation (high-speed internal CR)	-	3	TBD	mA	Peripheral : 4MHz* <sup>2</sup> *1
			SLEEP operation (sub oscillation)	-	1	TBD	mA	Peripheral : 32kHz *1
			SLEEP operation (low-speed internal CR)	-	1	TBD	mA	Peripheral : 100kHz *1

Parameter	Symbol	Pin name	Conditions	Value			Unit	Remarks
				Min	Typ	Max		
Power supply current	I <sub>CCH</sub>	VCC	STOP mode	-	0.8	TBD	mA	Ta = + 25°C, When LVD is off *1, *3
				-	-	TBD	mA	Ta = + 85°C, When LVD is off *1
	I <sub>CCT</sub>		TIMER mode (sub oscillation)	-	TBD	TBD	mA	Ta = + 25°C, When LVD is off *1
				-	-	TBD	mA	Ta = + 85°C, When LVD is off *1
Low-voltage detection circuit (LVD) power supply current	I <sub>CLVD</sub>		At operation	-	TBD	TBD	mA	For occurrence of interrupt

\*1: When all ports are fixed.

\*2: When setting it to 4MHz by trimming.

\*3: Estimated values

## (2) Pin Characteristics

(V<sub>cc</sub> = AV<sub>cc</sub> = 2.7V to 5.5V, V<sub>ss</sub> = AV<sub>ss</sub> = 0V, T<sub>a</sub> = - 40°C to + 85°C)

Parameter	Symbol	Pin name	Conditions	Value			Unit	Remarks
				Min	Typ	Max		
"H" level input voltage (hysteresis input)	V <sub>IHS</sub>	CMOS hysteresis input pin, MD0, MD1	-	V <sub>cc</sub> × 0.8	-	V <sub>cc</sub> + 0.3	V	
		5V tolerant input pin	-	V <sub>cc</sub> × 0.8	-	V <sub>ss</sub> + 5.5	V	
"L" level input voltage (hysteresis input)	V <sub>ILS</sub>	CMOS hysteresis input pin, MD0, MD1	-	V <sub>ss</sub> - 0.3	-	V <sub>cc</sub> × 0.2	V	
		5V tolerant input pin	-	V <sub>ss</sub> - 0.3	-	V <sub>cc</sub> × 0.2	V	
"H" level output voltage	V <sub>OH</sub>	4mA type	V <sub>cc</sub> ≥ 4.5 V I <sub>OH</sub> = - 4mA	V <sub>cc</sub> - 0.5	-	V <sub>cc</sub>	V	
			V <sub>cc</sub> < 4.5 V I <sub>OH</sub> = - 2mA					
		12mA type	V <sub>cc</sub> ≥ 4.5 V I <sub>OH</sub> = - 12mA	V <sub>cc</sub> - 0.5	-	V <sub>cc</sub>	V	
			V <sub>cc</sub> < 4.5 V I <sub>OH</sub> = - 8mA					

Parameter	Symbol	Pin name	Conditions	Value			Unit	Remarks
				Min	Typ	Max		
"L" level output voltage	$V_{OL}$	4mA type	$V_{CC} \geq 4.5\text{ V}$ $I_{OL} = 4\text{ mA}$	Vss	-	0.4	V	
			$V_{CC} < 4.5\text{ V}$ $I_{OL} = 2\text{ mA}$					
		12mA type	$V_{CC} \geq 4.5\text{ V}$ $I_{OL} = 12\text{ mA}$	Vss	-	0.4	V	
			$V_{CC} < 4.5\text{ V}$ $I_{OL} = 8\text{ mA}$					
Input leak current	$I_{IL}$	-	-	-5	-	+5	$\mu\text{A}$	
Pull-up resistance value	$R_{PU}$	Pull-up pin	$V_{CC} \geq 4.5\text{ V}$	25	50	100	$\text{k}\Omega$	
			$V_{CC} < 4.5\text{ V}$	30	80	200		
Input capacitance	$C_{IN}$	Other than VCC, VSS, AVCC, AVSS, AVRH	-	-	5	15	pF	

## 4. AC Characteristics

### (1) Main Clock Input Characteristics

(Vcc = 2.7V to 5.5V, Vss = 0V, Ta = - 40°C to + 85°C)

Parameter	Symbol	Pin name	Conditions	Value		Unit	Remarks
				Min	Max		
Input frequency	F <sub>CH</sub>	X0 X1	V <sub>cc</sub> ≥ 4.5V	4	48	MHz	When crystal oscillator is connected
			V <sub>cc</sub> < 4.5V	4	20		
			V <sub>cc</sub> ≥ 4.5V	4	48	MHz	
			V <sub>cc</sub> < 4.5V	4	20		
Input clock cycle	t <sub>CY<sub>LH</sub></sub>		V <sub>cc</sub> ≥ 4.5V	20.83	250	ns	When using external clock
			V <sub>cc</sub> < 4.5V	50	250		
Input clock pulse width	-		P <sub>WH</sub> /t <sub>CY<sub>LH</sub></sub> P <sub>WL</sub> /t <sub>CY<sub>LH</sub></sub>	45	55	%	When using external clock
Input clock rise time and fall time	t <sub>CF</sub> , t <sub>CR</sub>		-	-	5	ns	When using external clock
Internal operating clock* <sup>1</sup> frequency	F <sub>CC</sub>	-	-	-	144	MHz	Base clock (HCLK/FCLK)
	F <sub>CP0</sub>	-	-	-	72	MHz	APB0 bus clock* <sup>2</sup>
	F <sub>CP1</sub>	-	-	-	72	MHz	APB1 bus clock* <sup>2</sup>
	F <sub>CP2</sub>	-	-	-	72	MHz	APB2 bus clock* <sup>2</sup>
Internal operating clock* <sup>1</sup> cycle time	t <sub>CY<sub>CC</sub></sub>	-	-	6.94	-	ns	Base clock (HCLK/FCLK)
	t <sub>CY<sub>CP0</sub></sub>	-	-	13.8	-	ns	APB0 bus clock* <sup>2</sup>
	t <sub>CY<sub>CP1</sub></sub>	-	-	13.8	-	ns	APB1 bus clock* <sup>2</sup>
	t <sub>CY<sub>CP2</sub></sub>	-	-	13.8	-	ns	APB2 bus clock* <sup>2</sup>

\*1: For more information about each internal operating clock, see "Chapter:Clock" in "FM3 MB9Axxx/MB9Bxxx Series PERIPHERAL MANUAL".

\*2: For about each APB bus which each peripheral is connected to, see "■ BLOCK DIAGRAM" in this data sheet.

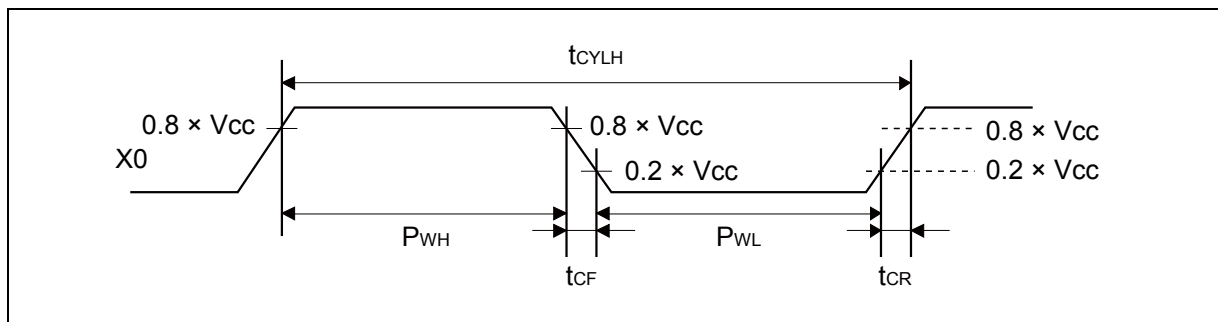



(2) Sub Clock Input Characteristics

(Vcc = 2.7V to 5.5V, Vss = 0V, Ta = - 40°C to + 85°C)

Parameter	Symbol	Pin name	Conditions	Value			Unit	Remarks
				Min	Typ	Max		
Input frequency	1/ t <sub>CYLL</sub>	X0A X1A	-	-	32.768	-	kHz	When crystal oscillator is connected
			-	32	-	100	kHz	When using external clock
Input clock cycle	t <sub>CYLL</sub>		-	10	-	31.25	μs	When using external clock
Input clock pulse width	-		P <sub>WH</sub> /t <sub>CYLL</sub> P <sub>WL</sub> /t <sub>CYLL</sub>	45	-	55	%	When using external clock

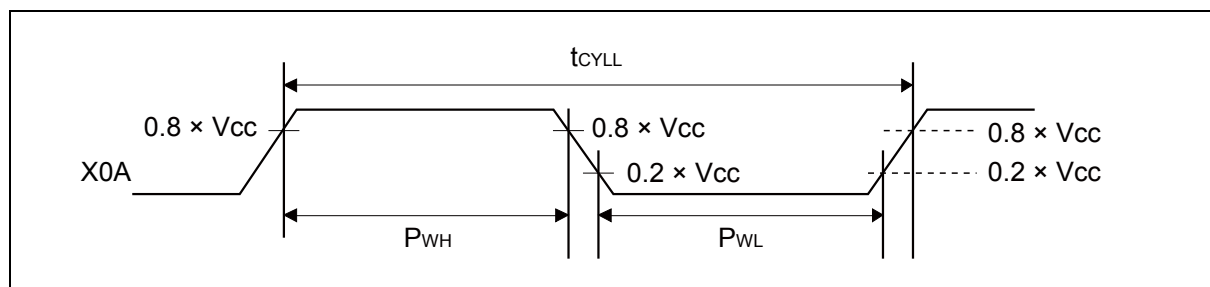

(3) Internal CR Oscillation Characteristics

- High-speed Internal CR

(Vcc = 2.7V to 5.5V, Vss = 0V, Ta = - 40°C to + 85°C)

Parameter	Symbol	Conditions	Value			Unit	Remarks
			Min	Typ	Max		
Clock frequency	F <sub>CRH</sub>	Ta = + 25°C	3.96	4	4.04	MHz	When trimming*
		Ta = 0°C to + 70°C	3.84	4	4.16		
		Ta = - 40°C to + 85°C	3.8	4	4.2		
		Ta = - 40°C to + 85°C	3	4	5		When not trimming

\*: In the case of using the values in CR trimming area of Flash memory at shipment for frequency trimming.

- Low-speed Internal CR

(Vcc = 2.7V to 5.5V, Vss = 0V, Ta = - 40°C to + 85°C)

Parameter	Symbol	Conditions	Value			Unit	Remarks
			Min	Typ	Max		
Clock frequency	F <sub>CRL</sub>	-	50	100	150	kHz	

### (4-1) Operating Conditions of Main PLL (In the case of using main clock for input of PLL)

(V<sub>CC</sub> = 2.7V to 5.5V, V<sub>SS</sub> = 0V, T<sub>a</sub> = - 40°C to + 85°C)

Parameter	Symbol	Value			Unit	Remarks
		Min	Typ	Max		
PLL oscillation stabilization wait time* (LOCK UP time)	t <sub>LOCK</sub>	100	-	-	μs	
PLL input clock frequency	F <sub>PLLI</sub>	4	-	16	MHz	
PLL multiple rate	-	13	-	75	multiple	
PLL macro oscillation clock frequency	F <sub>PLLO</sub>	200	-	300	MHz	

\*: Time from when the PLL starts operating until the oscillation stabilizes.

### (4-2) Operating Conditions of Main PLL (In the case of using high-speed internal CR)

(V<sub>CC</sub> = 2.7V to 5.5V, V<sub>SS</sub> = 0V, T<sub>a</sub> = - 40°C to + 85°C)

Parameter	Symbol	Value			Unit	Remarks
		Min	Typ	Max		
PLL oscillation stabilization wait time* (LOCK UP time)	t <sub>LOCK</sub>	100	-	-	μs	
PLL input clock frequency	F <sub>PLLI</sub>	3.8	4	4.2	MHz	
PLL multiple rate	-	50	-	71	multiple	
PLL macro oscillation clock frequency	F <sub>PLLO</sub>	190	-	300	MHz	

\*: Time from when the PLL starts operating until the oscillation stabilizes.

Note: It needs to input to PLL by internal CR trimming frequency.

### (5) Reset Input Characteristics

(V<sub>CC</sub> = 2.7V to 5.5V, V<sub>SS</sub> = 0V, T<sub>a</sub> = - 40°C to + 85°C)

Parameter	Symbol	Pin name	Conditions	Value		Unit	Remarks
				Min	Max		
Reset input time	t <sub>INITX</sub>	INITX	-	500	-	ns	

### (6) Power-on Reset Timing

(V<sub>CC</sub> = 2.7V to 5.5V, V<sub>SS</sub> = 0V, T<sub>a</sub> = - 40°C to + 85°C)

Parameter	Symbol	Pin name	Value		Unit	Remarks
			Min	Max		
Power supply rising time	Tr	VCC	0	-	ms	
Power supply shut down time	Toff		1	-	ms	

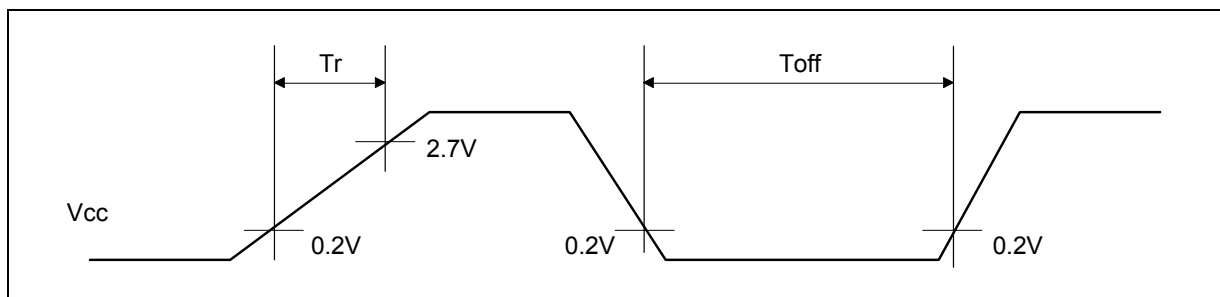

(7) External Bus Timing

- External bus clock output characteristics

(V<sub>CC</sub> = 2.7V to 5.5V, V<sub>SS</sub> = 0V, Ta = - 40°C to + 85°C)

Parameter	Symbol	Pin name	Conditions	Value		Unit
				Min	Max	
Output frequency	t <sub>CYCLE</sub>	MCLKOUT*1	V <sub>CC</sub> ≥ 4.5 V	-	50*2	MHz
			V <sub>CC</sub> < 4.5 V	-	32*3	MHz

\*1: External bus clock (MCLKOUT) is divided clock of HCLK.

For more information about setting of clock divider, see "Chapter:External Bus Interface" in "FM3 MB9Axxx/MB9Bxxx Series PERIPHERAL MANUAL".

\*2: When AHB bus clock frequency is more than 100MHz, the divider setting for MCLKOUT must be more than 4.

\*3: When AHB bus clock frequency is more than 64MHz, the divider setting for MCLKOUT must be more than 4.

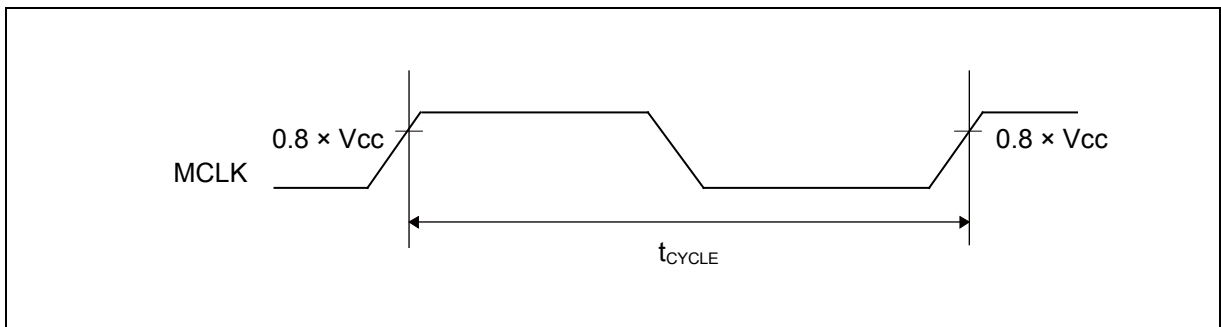

- External bus signal input/output characteristics

(V<sub>CC</sub> = 2.7V to 5.5V, V<sub>SS</sub> = 0V, Ta = - 40°C to + 85°C)

Parameter	Symbol	Conditions	Value	Unit	Remarks
Signal input characteristics	V <sub>IH</sub>	-	0.8 × V <sub>CC</sub>	V	
	V <sub>IL</sub>		0.2 × V <sub>CC</sub>	V	
Signal output characteristics	V <sub>OH</sub>		0.8 × V <sub>CC</sub>	V	
	V <sub>OL</sub>		0.2 × V <sub>CC</sub>	V	

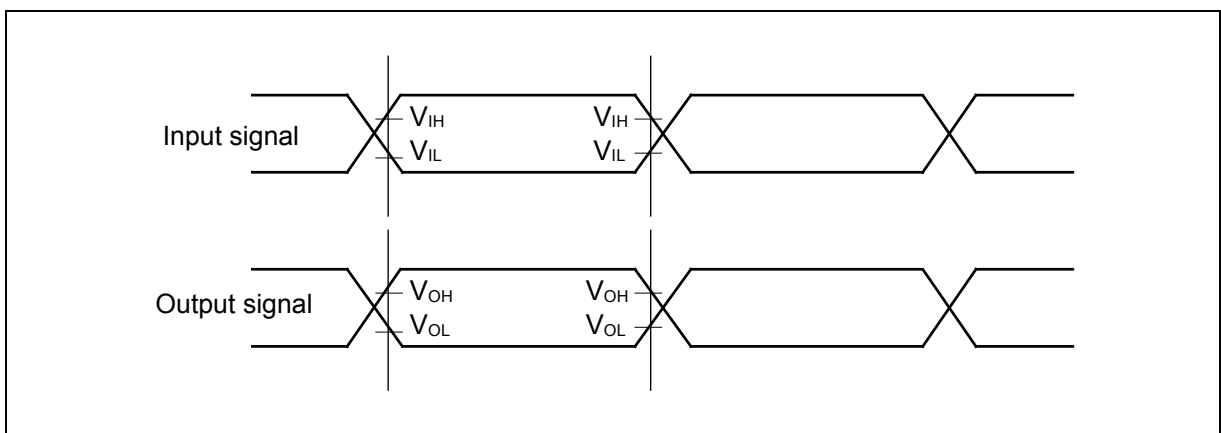

• Separate Bus Access Asynchronous SRAM Mode

(V<sub>CC</sub> = 2.7V to 5.5V, V<sub>SS</sub> = 0V, T<sub>a</sub> = -40°C to +85°C)

Parameter	Symbol	Pin name	Conditions	Value		Unit
				Min	Max	
MOEX Min pulse width	t <sub>OE<sub>W</sub></sub>	MOEX	V <sub>CC</sub> ≥ 4.5V	MCLK×n-3	-	ns
			V <sub>CC</sub> < 4.5V			
MCSX ↓ → Address output delay time	t <sub>CSL-AV</sub>	MCSX[7:0] MAD[24:0]	V <sub>CC</sub> ≥ 4.5V	-9	+9	ns
			V <sub>CC</sub> < 4.5V	-12	+12	
MOEX ↑ → Address hold time	t <sub>OE<sub>H</sub>-AX</sub>	MOEX MAD[24:0]	V <sub>CC</sub> ≥ 4.5V	0	MCLK×m+9	ns
			V <sub>CC</sub> < 4.5V		MCLK×m+12	
MCSX ↓ → MOEX ↓ delay time	t <sub>CSL-OEL</sub>	MOEX MCSX[7:0]	V <sub>CC</sub> ≥ 4.5V	MCLK×m-9	MCLK×m+9	ns
			V <sub>CC</sub> < 4.5V	MCLK×m-12	MCLK×m+12	
MOEX ↑ → MCSX ↑ time	t <sub>OE<sub>H</sub>-CSH</sub>		V <sub>CC</sub> ≥ 4.5V	0	MCLK×m+9	ns
			V <sub>CC</sub> < 4.5V		MCLK×m+12	
MCSX ↓ → MDQM ↓ delay time	t <sub>CSL-RDQML</sub>	MCSX MDQM[1:0]	V <sub>CC</sub> ≥ 4.5V	MCLK×m-9	MCLK×m+9	ns
			V <sub>CC</sub> < 4.5V	MCLK×m-12	MCLK×m+12	
Data set up → MOEX ↑ time	t <sub>DS-OE</sub>	MOEX MADATA[15:0]	V <sub>CC</sub> ≥ 4.5V	20	-	ns
			V <sub>CC</sub> < 4.5V	38	-	
MOEX ↑ → Data hold time	t <sub>DH-OE</sub>	MOEX MADATA[15:0]	V <sub>CC</sub> ≥ 4.5V	0	-	ns
			V <sub>CC</sub> < 4.5V			
MWEX Min pulse width	t <sub>WE<sub>W</sub></sub>	MWEX	V <sub>CC</sub> ≥ 4.5V	MCLK×n-3	-	ns
			V <sub>CC</sub> < 4.5V			
MWEX ↑ → Address output delay time	t <sub>WE<sub>H</sub>-AX</sub>	MWEX MAD[24:0]	V <sub>CC</sub> ≥ 4.5V	0	MCLK×m+9	ns
			V <sub>CC</sub> < 4.5V		MCLK×m+12	
MCSX ↓ → MWEX ↓ delay time	t <sub>CSL-WEL</sub>	MWEX MCSX[7:0]	V <sub>CC</sub> ≥ 4.5V	MCLK×n-9	MCLK×n+9	ns
			V <sub>CC</sub> < 4.5V	MCLK×n-12	MCLK×n+12	
MWEX ↑ → MCSX ↑ delay time	t <sub>WE<sub>H</sub>-CSH</sub>		V <sub>CC</sub> ≥ 4.5V	0	MCLK×m+9	ns
			V <sub>CC</sub> < 4.5V		MCLK×m+12	
MCSX ↓ → MDQM ↓ delay time	t <sub>CSL-WDQML</sub>	MCSX MDQM[1:0]	V <sub>CC</sub> ≥ 4.5V	MCLK×n-9	MCLK×n+9	ns
			V <sub>CC</sub> < 4.5V	MCLK×n-12	MCLK×n+12	
MWEX ↓ → Data output time	t <sub>WEL-DV</sub>	MWEX MADATA[15:0]	V <sub>CC</sub> ≥ 4.5V	-9	+9	ns
			V <sub>CC</sub> < 4.5V	-12	+12	
MWEX ↑ → Data hold time	t <sub>WE<sub>H</sub>-DX</sub>		V <sub>CC</sub> ≥ 4.5V	0	MCLK×m+9	ns
			V <sub>CC</sub> < 4.5V		MCLK×m+12	

Note: When the external load capacitance = 30pF. (m = 0 to 15, n = 1 to 16)

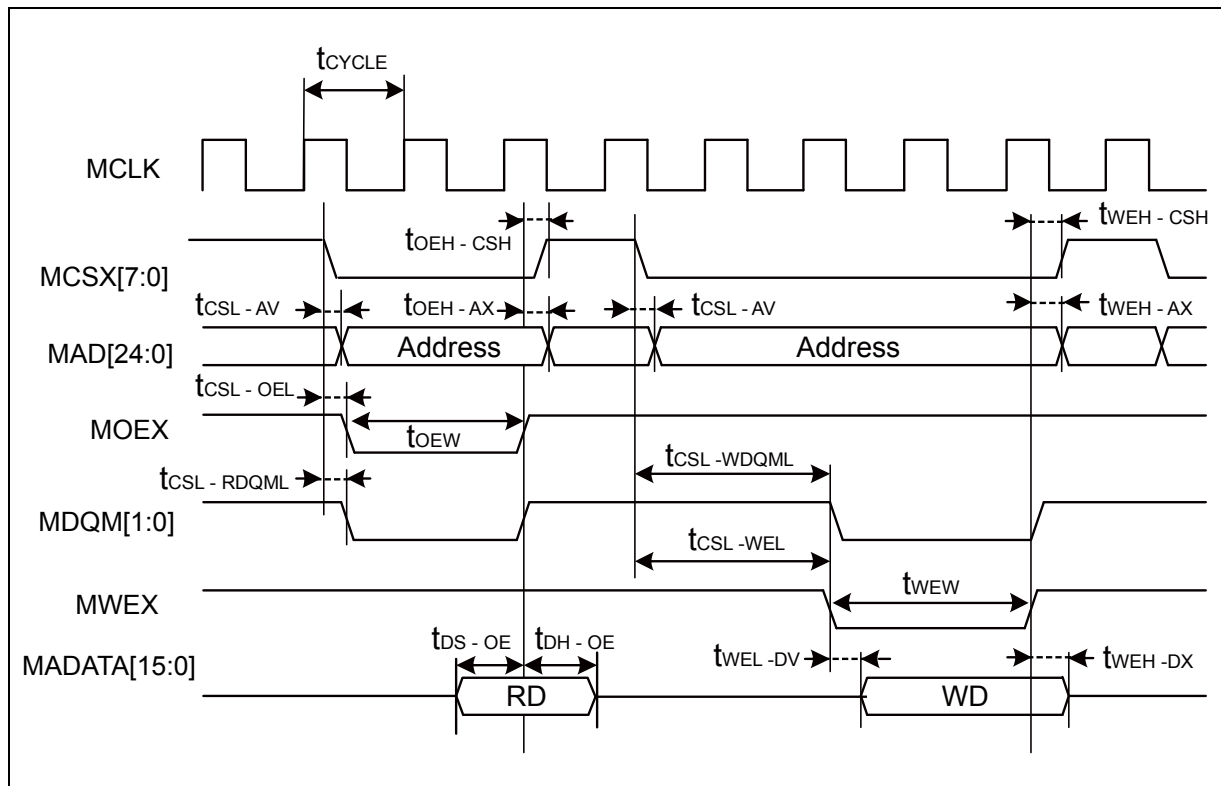

• Separate Bus Access Synchronous SRAM Mode

( $V_{CC} = 2.7V$  to  $5.5V$ ,  $V_{SS} = 0V$ ,  $T_a = -40^{\circ}C$  to  $+85^{\circ}C$ )

Parameter	Symbol	Pin name	Conditions	Value		Unit
				Min	Max	
Address delay time	$t_{AV}$	MCLK MAD[24:0]	$V_{CC} \geq 4.5V$	1	9	ns
			$V_{CC} < 4.5V$		12	
MCSX delay time	$t_{CSL}$	MCLK MCSX[7:0]	$V_{CC} \geq 4.5V$	1	9	ns
			$V_{CC} < 4.5V$		12	
	$t_{CSH}$		$V_{CC} \geq 4.5V$	1	9	ns
			$V_{CC} < 4.5V$		12	
MOEX delay time	$t_{REL}$	MCLK MOEX	$V_{CC} \geq 4.5V$	1	9	ns
			$V_{CC} < 4.5V$		12	
	$t_{REH}$		$V_{CC} \geq 4.5V$	1	9	ns
			$V_{CC} < 4.5V$		12	
Data set up → MCLK ↑ time	$t_{DS}$	MCLK MADATA[15:0]	$V_{CC} \geq 4.5V$	19	-	ns
			$V_{CC} < 4.5V$	37		
MCLK ↑ → Data hold time	$t_{DH}$	MCLK MADATA[15:0]	$V_{CC} \geq 4.5V$	0	-	ns
			$V_{CC} < 4.5V$			
MWEX delay time	$t_{WEL}$	MCLK MWEX	$V_{CC} \geq 4.5V$	1	9	ns
			$V_{CC} < 4.5V$		12	
	$t_{WEH}$		$V_{CC} \geq 4.5V$	1	9	ns
			$V_{CC} < 4.5V$		12	
MDQM[1:0] delay time	$t_{DQML}$	MCLK MDQM[1:0]	$V_{CC} \geq 4.5V$	1	9	ns
			$V_{CC} < 4.5V$		12	
	$t_{DQMH}$		$V_{CC} \geq 4.5V$	1	9	ns
			$V_{CC} < 4.5V$		12	
MCLK ↑ → Data output time	$t_{OD}$	MCLK MADATA[15:0]	$V_{CC} \geq 4.5V$	1	18	ns
			$V_{CC} < 4.5V$		24	

Note: When the external load capacitance = 30pF.

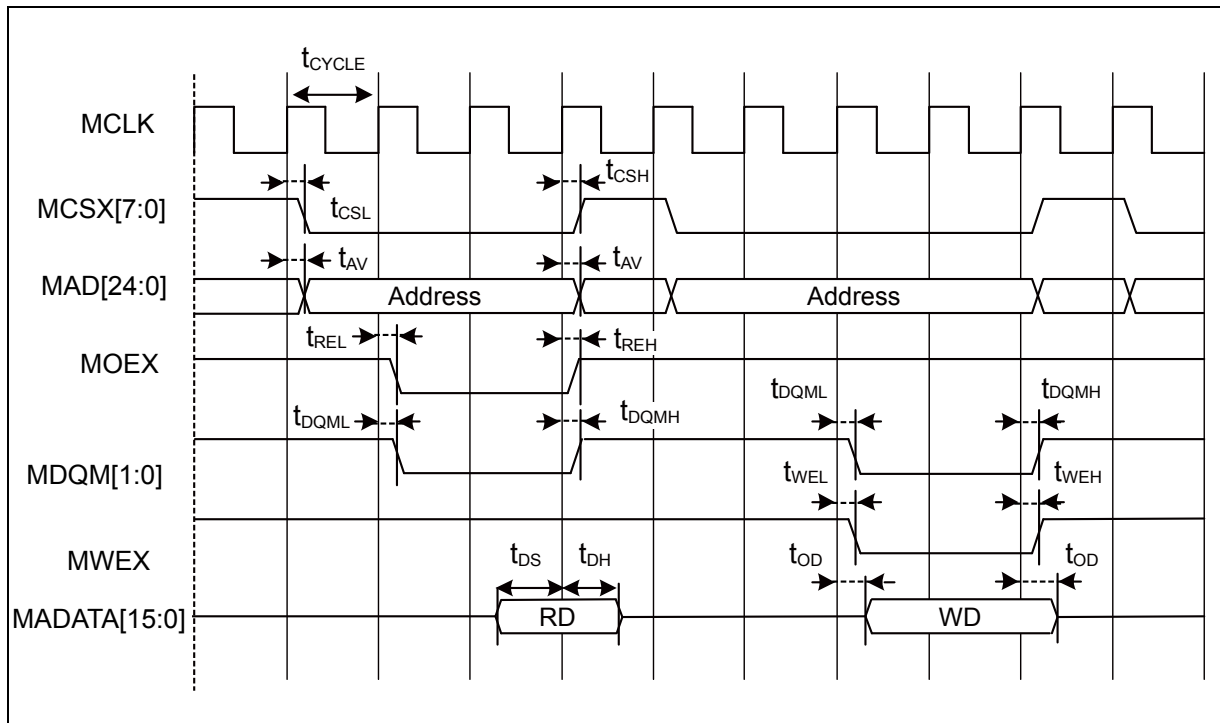

• Multiplexed Bus Access Asynchronous SRAM Mode

(Vcc = 2.7V to 5.5V, Vss = 0V, Ta = - 40°C to + 85°C)

Parameter	Symbol	Pin name	Conditions	Value		Unit
				Min	Max	
Multiplexed address delay time	$t_{ALE-CHMADV}$	MALE MADATA[15:0]	$V_{cc} \geq 4.5V$	0	10	ns
			$V_{cc} < 4.5V$		20	
Multiplexed address hold time	$t_{CHMADH}$	MALE MADATA[15:0]	$V_{cc} \geq 4.5V$	$MCLK \times n + 0$	$MCLK \times n + 10$	ns
			$V_{cc} < 4.5V$	$MCLK \times n + 0$	$MCLK \times n + 20$	

Note: When the external load capacitance = 30pF. (m = 0 to 15, n = 1 to 16)

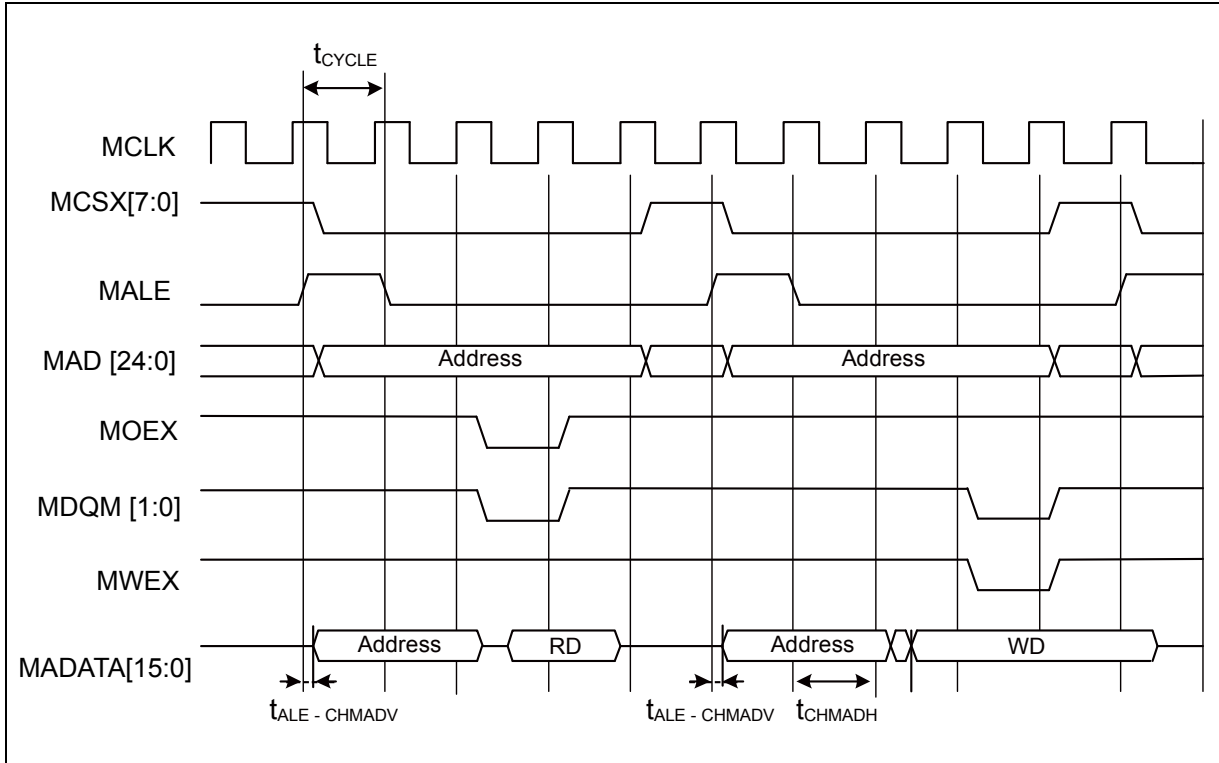

• Multiplexed Bus Access Synchronous SRAM Mode

(Vcc = 2.7V to 5.5V, Vss = 0V, Ta = - 40°C to + 85°C)

Parameter	Symbol	Pin name	Conditions	Value		Unit	Remarks
				Min	Max		
MALE delay time	t <sub>CHAL</sub>	MCLK ALE	Vcc ≥ 4.5V	1	9	ns	
			Vcc < 4.5V		12		
	t <sub>CHAH</sub>		Vcc ≥ 4.5V	1	9	ns	
			Vcc < 4.5V		12		
MCLK ↑ → Multiplexed Address delay time	t <sub>CHMADV</sub>	MCLK MADATA[15:0]	Vcc ≥ 4.5V	1	t <sub>OD</sub>	ns	
Vcc < 4.5V							
MCLK ↑ → Multiplexed Data output time	t <sub>CHMADX</sub>	MCLK MADATA[15:0]	Vcc ≥ 4.5V	1	t <sub>OD</sub>	ns	
Vcc < 4.5V							

Note: When the external load capacitance = 30pF.

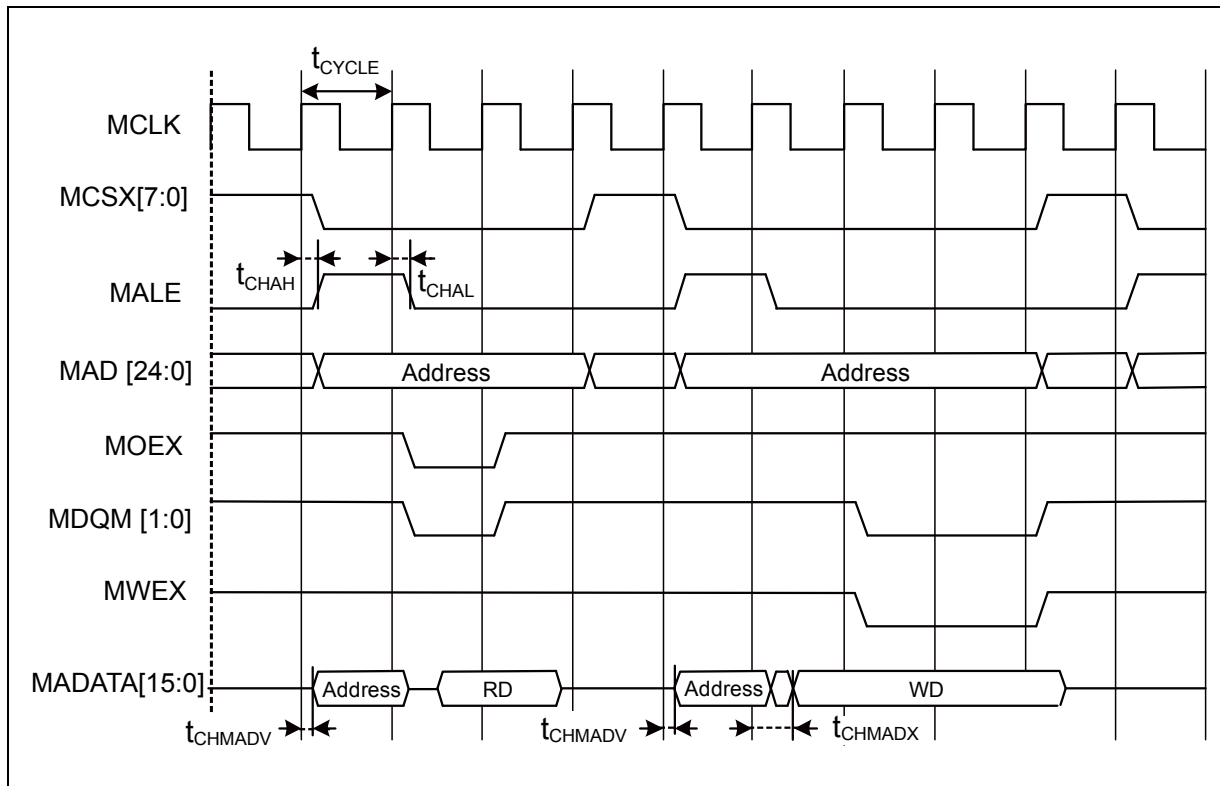



• NAND Flash Mode

(V<sub>CC</sub> = 2.7V to 5.5V, V<sub>SS</sub> = 0V, T<sub>a</sub> = -40°C to +85°C)

Parameter	Symbol	Pin name	Conditions	Value		Unit
				Min	Max	
MNREX Min pulse width	t <sub>NREW</sub>	MNREX	V <sub>CC</sub> ≥ 4.5V V <sub>CC</sub> < 4.5V	MCLK×n-3	-	ns
Data setup → MNREX ↑ time	t <sub>DS-NRE</sub>	MNREX MADATA[15:0]	V <sub>CC</sub> ≥ 4.5V V <sub>CC</sub> < 4.5V	20 38	- -	ns
MNREX ↑ → Data hold time	t <sub>DH-NRE</sub>	MNREX MADATA[15:0]	V <sub>CC</sub> ≥ 4.5V V <sub>CC</sub> < 4.5V	0	-	ns
MNALE ↑ → MNWEX delay time	t <sub>ALEH-NWEL</sub>	MNALE MNWEX	V <sub>CC</sub> ≥ 4.5V V <sub>CC</sub> < 4.5V	MCLK×m-9 MCLK×m-12	MCLK×m+9 MCLK×m+12	ns
MNALE ↓ → MNWEX delay time	t <sub>ALEL-NWEL</sub>	MNALE MNWEX	V <sub>CC</sub> ≥ 4.5V V <sub>CC</sub> < 4.5V	MCLK×m-9 MCLK×m-12	MCLK×m+9 MCLK×m+12	ns
MNCLE ↑ → MNWEX delay time	t <sub>CLEH-NWEL</sub>	MNCLE MNWEX	V <sub>CC</sub> ≥ 4.5V V <sub>CC</sub> < 4.5V	MCLK×m-9 MCLK×m-12	MCLK×m+9 MCLK×m+12	ns
MNWEH ↑ → MNCLE delay time	t <sub>NWEH-CLEL</sub>	MNCLE MNWEX	V <sub>CC</sub> ≥ 4.5V V <sub>CC</sub> < 4.5V	0	MCLK×m+9 MCLK×m+12	ns
MNWEH Min pulse width	t <sub>NWEW</sub>	MNWEH	V <sub>CC</sub> ≥ 4.5V V <sub>CC</sub> < 4.5V	MCLK×n-3	-	ns
MNWEH ↓ → Data delay time	t <sub>NWEL-DV</sub>	MNWEH MADATA[15:0]	V <sub>CC</sub> ≥ 4.5V V <sub>CC</sub> < 4.5V	-9 -12	+9 +12	ns
MNWEH ↑ → Data hold time	t <sub>NWEH-DX</sub>	MNWEH MADATA[15:0]	V <sub>CC</sub> ≥ 4.5V V <sub>CC</sub> < 4.5V	0	MCLK×m+9 MCLK×m+12	ns

Note: When the external load capacitance = 30pF. (m=0 to 15, n=1 to 16)

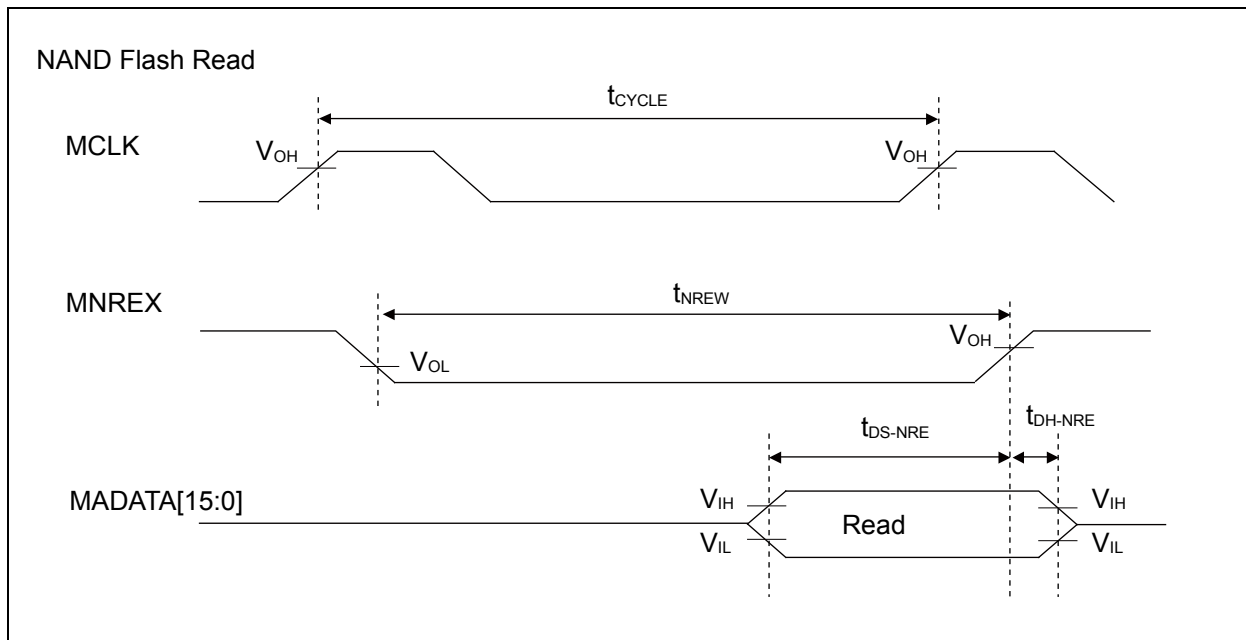

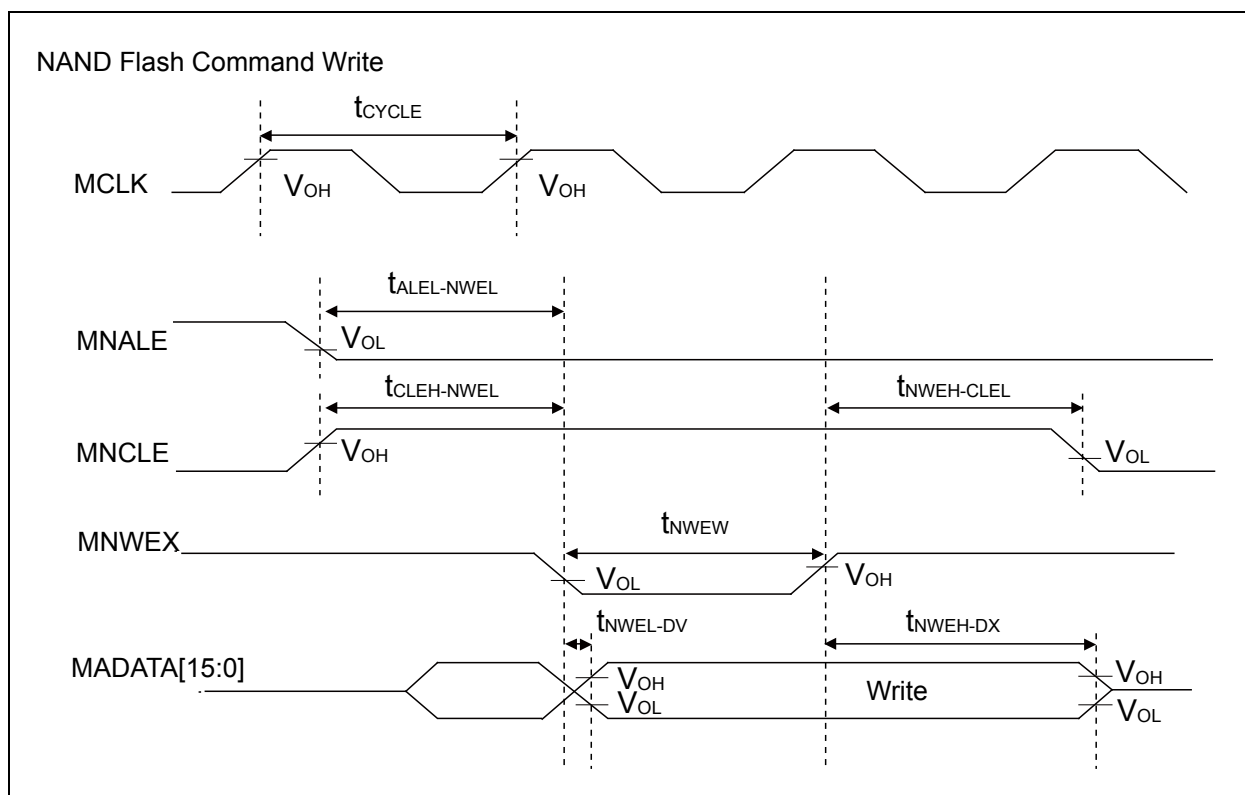
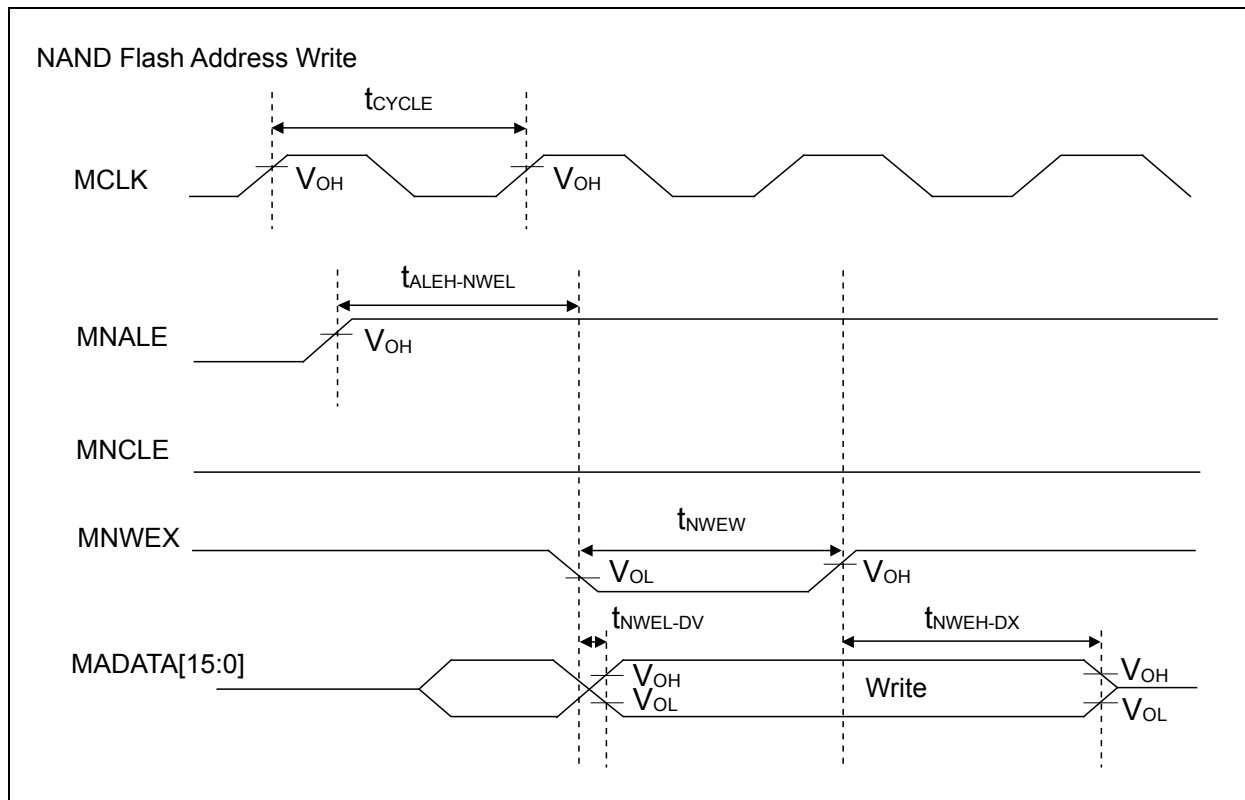

• External Ready Input Timing

( $V_{CC} = 2.7V$  to  $5.5V$ ,  $V_{SS} = 0V$ ,  $T_a = -40^{\circ}C$  to  $+85^{\circ}C$ )

Parameter	Symbol	Pin name	Conditions	Value		Unit	Remarks
				Min	Max		
MCLK $\uparrow$ MRDY input setup time	$t_{RDYI}$	MCLK MRDY	$V_{CC} \geq 4.5V$	19	-	ns	
			$V_{CC} < 4.5V$	37			

• When RDY is input

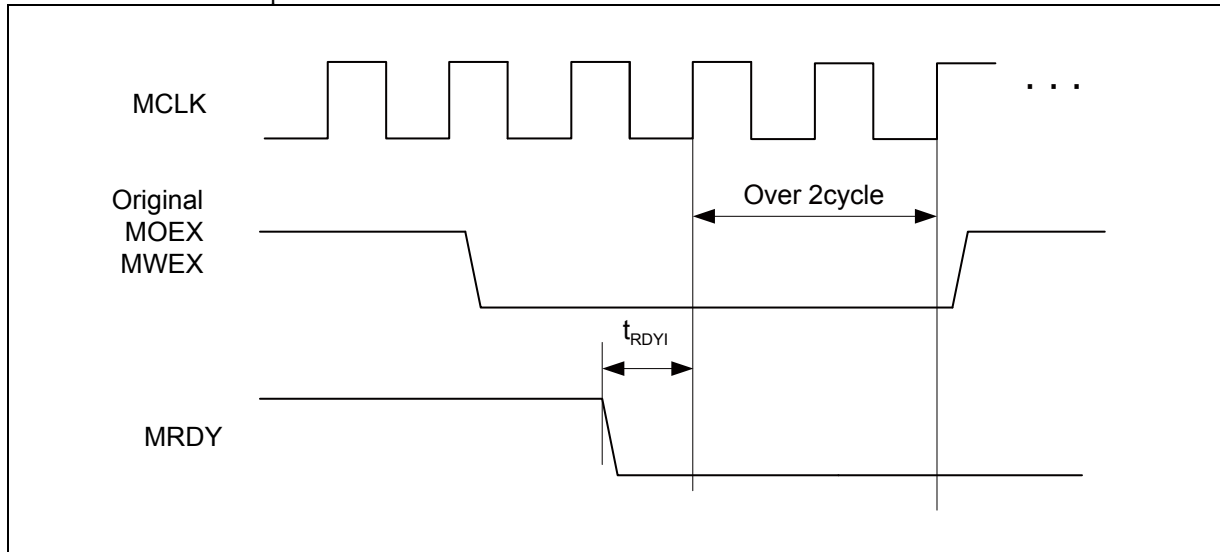

• When RDY is released

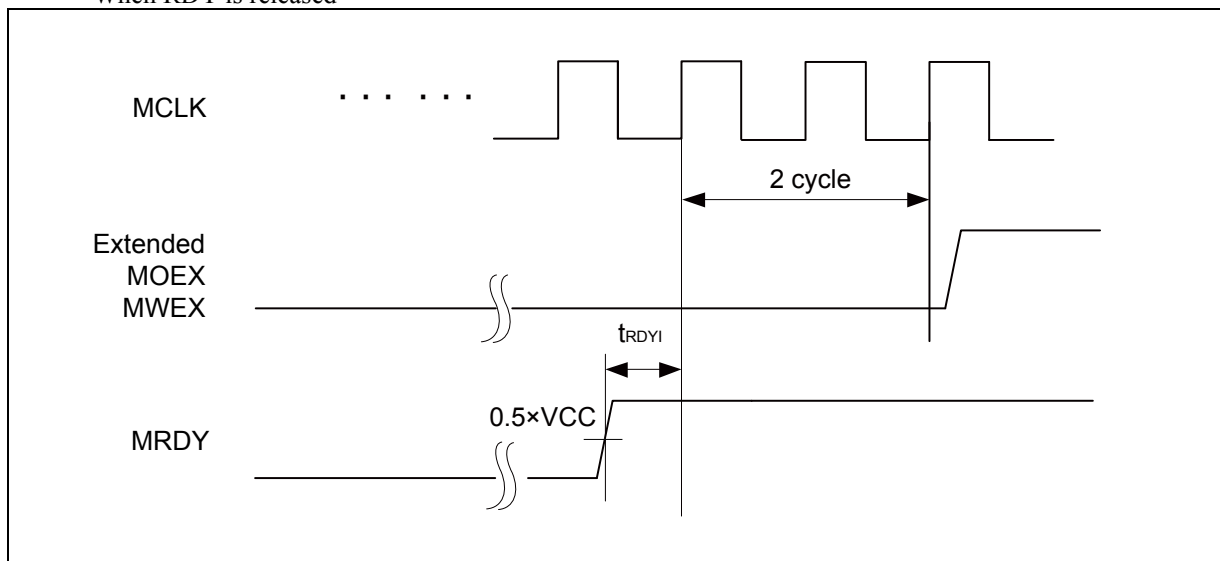

(8) Base Timer Input Timing

- Timer input timing

(V<sub>CC</sub> = 2.7V to 5.5V, V<sub>SS</sub> = 0V, T<sub>a</sub> = - 40°C to + 85°C)

Parameter	Symbol	Pin name	Conditions	Value		Unit	Remarks
				Min	Max		
Input pulse width	t <sub>TIWH</sub> t <sub>TIWL</sub>	TIOAn/TIOBn (when using as ECK, TIN)	-	2t <sub>CYCP</sub>	-	ns	

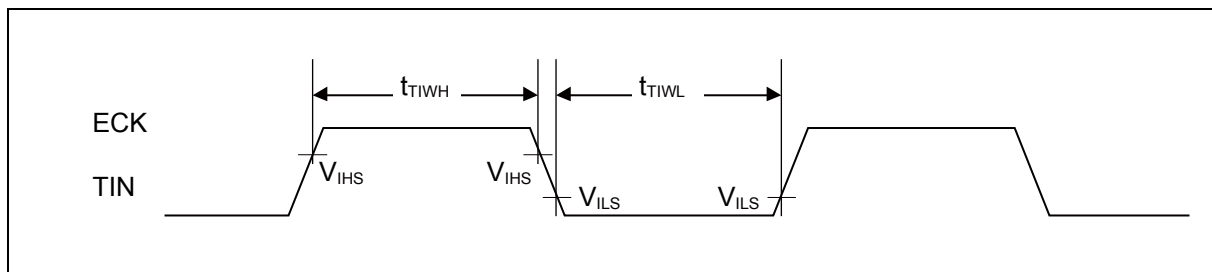

- Trigger input timing

(V<sub>CC</sub> = 2.7V to 5.5V, V<sub>SS</sub> = 0V, T<sub>a</sub> = - 40°C to + 85°C)

Parameter	Symbol	Pin name	Conditions	Value		Unit	Remarks
				Min	Max		
Input pulse width	t <sub>TRGH</sub> t <sub>TRGL</sub>	TIOAn/TIOBn (when using as TGIN)	-	2t <sub>CYCP</sub>	-	ns	

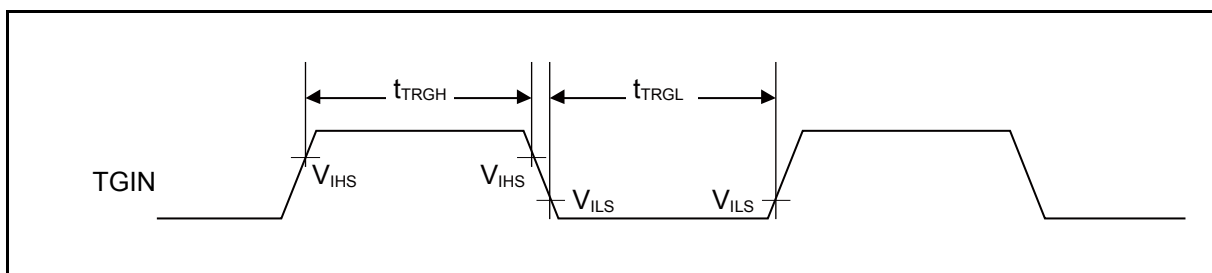

Note: t<sub>CYCP</sub> indicates the APB bus clock cycle time.

About the APB bus number which Base Timer is connected to, see "■BLOCK DIAGRAM" in this data sheet.

## (9) UART Timing

- Synchronous serial (SPI = 0, SCINV = 0)

(Vcc = 2.7V to 5.5V, Vss = 0V, Ta = - 40°C to + 85°C)

Parameter	Symbol	Pin name	Conditions	Vcc < 4.5V		Vcc ≥ 4.5V		Unit
				Min	Max	Min	Max	
Serial clock cycle time	t <sub>SCYC</sub>	SCK <sub>X</sub>	Internal shift clock operation	4tcycp	-	4tcycp	-	ns
SCK ↓ → SOT delay time	t <sub>SLOVI</sub>	SCK <sub>X</sub> SOT <sub>X</sub>		-30	+30	- 20	+ 20	ns
SIN → SCK ↑ setup time	t <sub>IVSHI</sub>	SCK <sub>X</sub> SIN <sub>X</sub>		50	-	30	-	ns
SCK ↑ → SIN hold time	t <sub>SHIXI</sub>	SCK <sub>X</sub> SIN <sub>X</sub>		0	-	0	-	ns
Serial clock "L" pulse width	t <sub>SLSH</sub>	SCK <sub>X</sub>	External shift clock operation	2tcycp - 10	-	2tcycp - 10	-	ns
Serial clock "H" pulse width	t <sub>SHSL</sub>	SCK <sub>X</sub>		tcycp + 10	-	tcycp + 10	-	ns
SCK ↓ → SOT delay time	t <sub>SLOVE</sub>	SCK <sub>X</sub> SOT <sub>X</sub>		-	50	-	30	ns
SIN → SCK ↑ setup time	t <sub>IVSHE</sub>	SCK <sub>X</sub> SIN <sub>X</sub>		10	-	10	-	ns
SCK ↑ → SIN hold time	t <sub>SHIXE</sub>	SCK <sub>X</sub> SIN <sub>X</sub>		20	-	20	-	ns
SCK fall time	t <sub>F</sub>	SCK <sub>X</sub>		-	5	-	5	ns
SCK rise time	t <sub>R</sub>	SCK <sub>X</sub>		-	5	-	5	ns

Notes: • The above characteristics apply to CLK synchronous mode.

- t<sub>CYCP</sub> indicates the APB bus clock cycle time.

About the APB bus number which UART is connected to, see "■BLOCK DIAGRAM" in this data sheet.

- These characteristics only guarantee the same relocate port number.

For example, the combination of SCLK<sub>X</sub>\_0 and SOT<sub>X</sub>\_1 is not guaranteed.

- When the external load capacitance = 30pF.

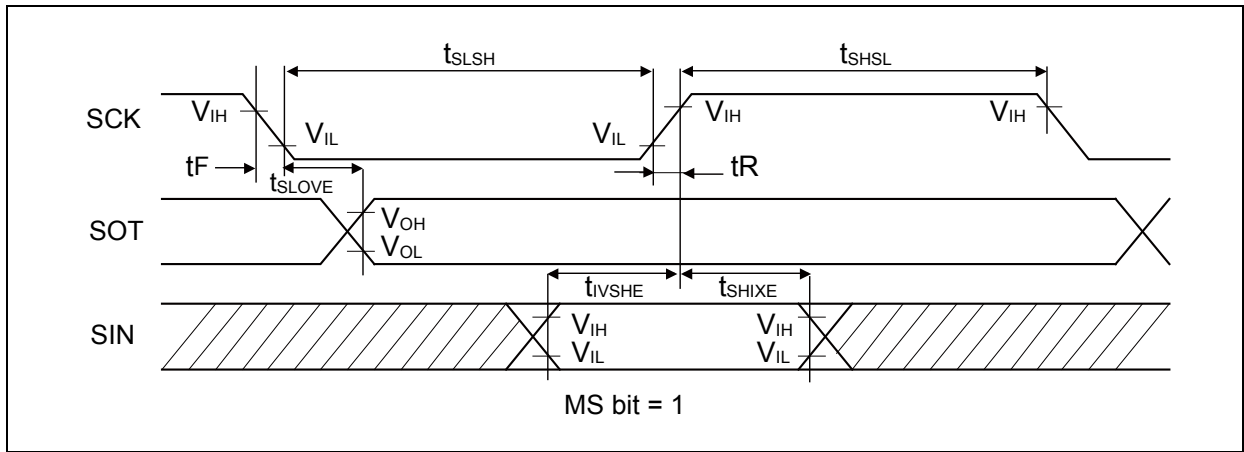
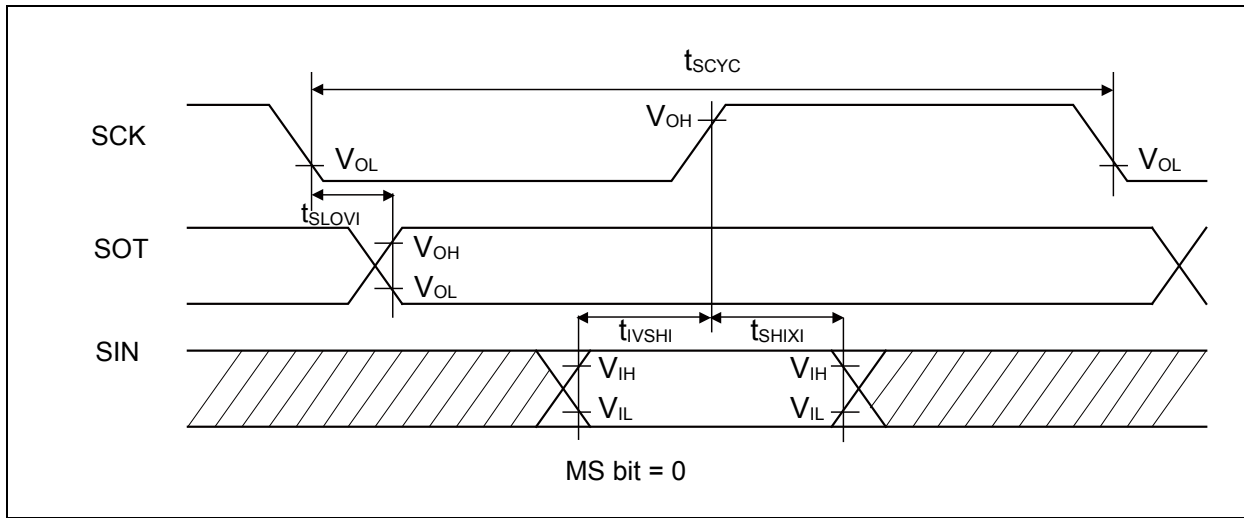

• Synchronous serial (SPI = 0, SCINV = 1)

(Vcc = 2.7V to 5.5V, Vss = 0V, Ta = - 40°C to + 85°C)

Parameter	Symbol	Pin name	Conditions	Vcc < 4.5V		Vcc ≥ 4.5V		Unit
				Min	Max	Min	Max	
Serial clock cycle time	t <sub>SCYC</sub>	SCK <sub>x</sub>	Internal shift clock operation	4tcycp	-	4tcycp	-	ns
SCK ↑ → SOT delay time	t <sub>SHOVI</sub>	SCK <sub>x</sub> SOT <sub>x</sub>		-30	+30	- 20	+ 20	ns
SIN → SCK ↓ setup time	t <sub>IVSLI</sub>	SCK <sub>x</sub> SIN <sub>x</sub>		50	-	30	-	ns
SCK ↓ → SIN hold time	t <sub>SLIXI</sub>	SCK <sub>x</sub> SIN <sub>x</sub>		0	-	0	-	ns
Serial clock "L" pulse width	t <sub>SLSH</sub>	SCK <sub>x</sub>	External shift clock operation	2tcycp - 10	-	2tcycp - 10	-	ns
Serial clock "H" pulse width	t <sub>SHSL</sub>	SCK <sub>x</sub>		tcycp + 10	-	tcycp + 10	-	ns
SCK ↑ → SOT delay time	t <sub>SHOVE</sub>	SCK <sub>x</sub> SOT <sub>x</sub>		-	50	-	30	ns
SIN → SCK ↓ setup time	t <sub>IVSLE</sub>	SCK <sub>x</sub> SIN <sub>x</sub>		10	-	10	-	ns
SCK ↓ → SIN hold time	t <sub>SLIXE</sub>	SCK <sub>x</sub> SIN <sub>x</sub>		20	-	20	-	ns
SCK fall time	t <sub>F</sub>	SCK <sub>x</sub>		-	5	-	5	ns
SCK rise time	t <sub>R</sub>	SCK <sub>x</sub>	-	5	-	5	ns	

Notes: • The above characteristics apply to CLK synchronous mode.

- t<sub>CYCP</sub> indicates the APB bus clock cycle time.  
About the APB bus number which UART is connected to, see "■BLOCK DIAGRAM" in this data sheet.
- These characteristics only guarantee the same relocate port number.  
For example, the combination of SCLK<sub>x\_0</sub> and SOT<sub>x\_1</sub> is not guaranteed.
- When the external load capacitance = 30pF.



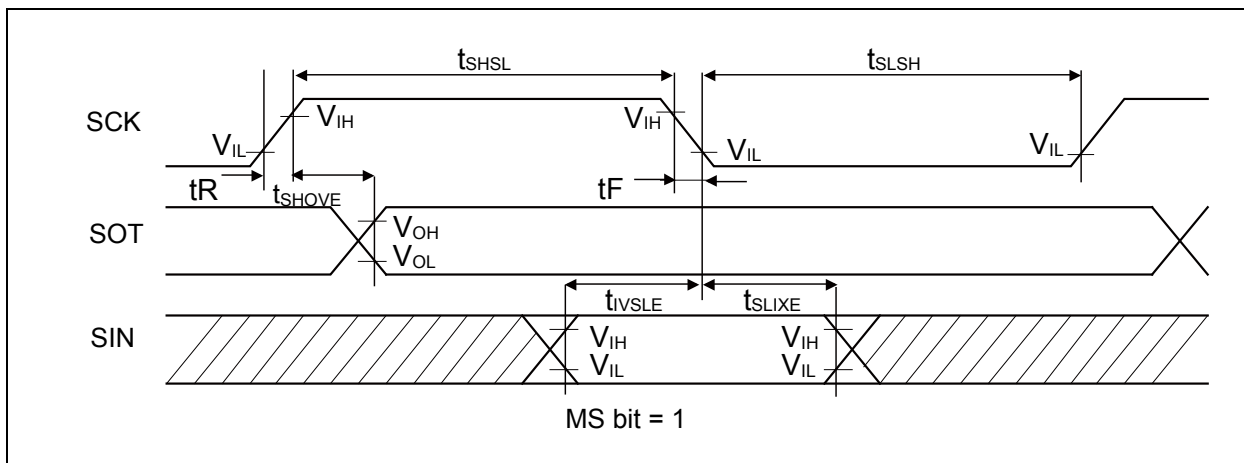
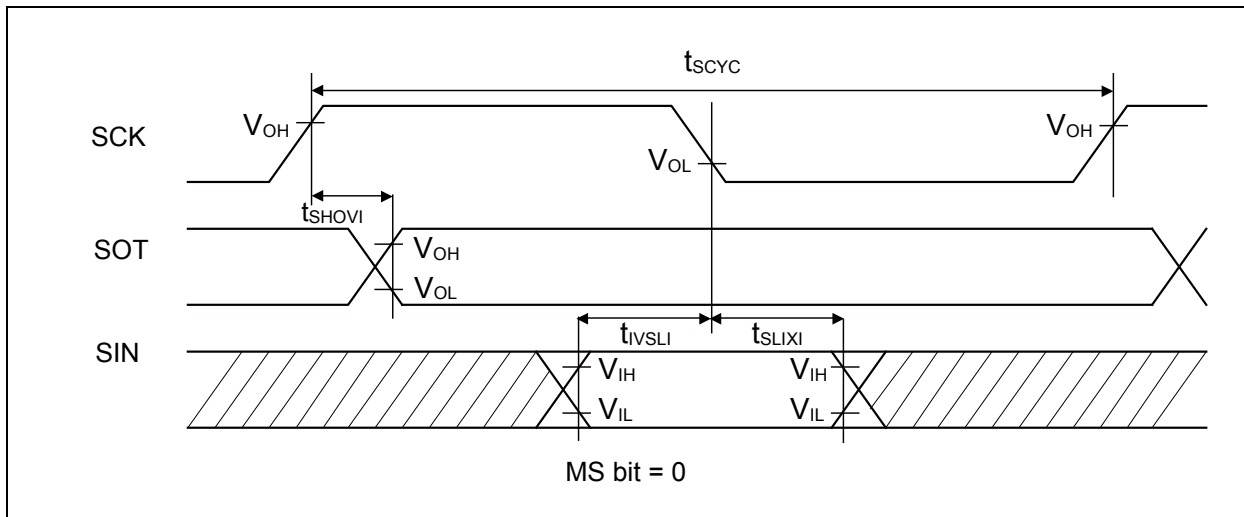

• Synchronous serial (SPI = 1, SCINV = 0)

(V<sub>CC</sub> = 2.7V to 5.5V, V<sub>SS</sub> = 0V, T<sub>a</sub> = - 40°C to + 85°C)

Parameter	Symbol	Pin name	Conditions	V <sub>CC</sub> < 4.5V		V <sub>CC</sub> ≥ 4.5V		Unit
				Min	Max	Min	Max	
Serial clock cycle time	t <sub>SCYC</sub>	SCK <sub>X</sub>	Internal shift clock operation	4tcycp	-	4tcycp	-	ns
SCK ↑ → SOT delay time	t <sub>SHOVI</sub>	SCK <sub>X</sub> SOT <sub>X</sub>		-30	+30	- 20	+ 20	ns
SIN → SCK ↓ setup time	t <sub>IVSLI</sub>	SCK <sub>X</sub> SIN <sub>X</sub>		50	-	30	-	ns
SCK ↓ → SIN hold time	t <sub>SLIXI</sub>	SCK <sub>X</sub> SIN <sub>X</sub>		0	-	0	-	ns
SOT → SCK ↓ delay time	t <sub>SOVLI</sub>	SCK <sub>X</sub> SOT <sub>X</sub>		2tcycp - 30	-	2tcycp - 30	-	ns
Serial clock "L" pulse width	t <sub>SLSH</sub>	SCK <sub>X</sub>		2tcycp - 10	-	2tcycp - 10	-	ns
Serial clock "H" pulse width	t <sub>SHSL</sub>	SCK <sub>X</sub>	tcycp + 10	-	tcycp + 10	-	ns	
SCK ↑ → SOT delay time	t <sub>SHOVE</sub>	SCK <sub>X</sub> SOT <sub>X</sub>	External shift clock operation	-	50	-	30	ns
SIN → SCK ↓ setup time	t <sub>IVSLE</sub>	SCK <sub>X</sub> SIN <sub>X</sub>		10	-	10	-	ns
SCK ↓ → SIN hold time	t <sub>SLIXE</sub>	SCK <sub>X</sub> SIN <sub>X</sub>		20	-	20	-	ns
SCK fall time	t <sub>F</sub>	SCK <sub>X</sub>		-	5	-	5	ns
SCK rise time	t <sub>R</sub>	SCK <sub>X</sub>		-	5	-	5	ns

Notes: • The above characteristics apply to CLK synchronous mode.

• t<sub>CYCP</sub> indicates the APB bus clock cycle time.

About the APB bus number which UART is connected to, see "■BLOCK DIAGRAM" in this data sheet.

• These characteristics only guarantee the same relocate port number.

For example, the combination of SCLK<sub>x\_0</sub> and SOT<sub>x\_1</sub> is not guaranteed.

• When the external load capacitance = 30pF.

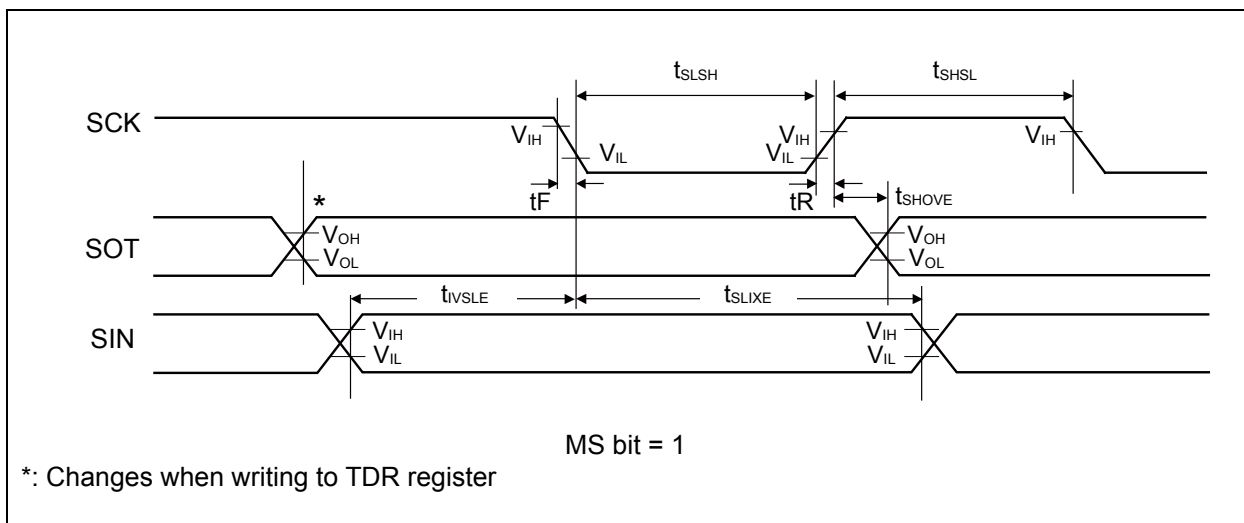
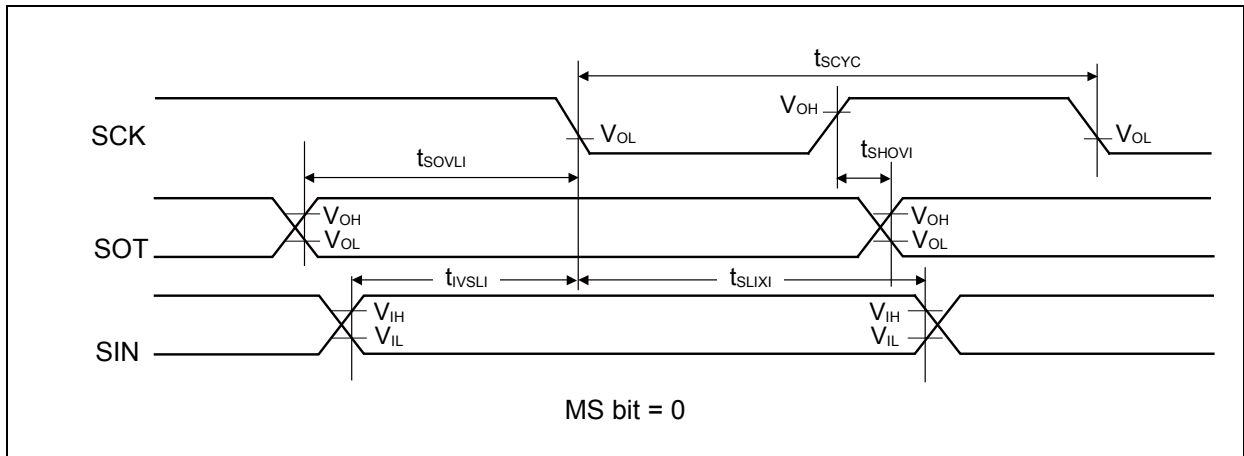

• Synchronous serial (SPI = 1, SCINV = 1)

(Vcc = 2.7V to 5.5V, Vss = 0V, Ta = - 40°C to + 85°C)

Parameter	Symbol	Pin name	Conditions	Vcc < 4.5V		Vcc ≥ 4.5V		Unit
				Min	Max	Min	Max	
Serial clock cycle time	t <sub>SCYC</sub>	SCKx	Internal shift clock operation	4tcycp	-	4tcycp	-	ns
SCK ↓ → SOT delay time	t <sub>SLOVI</sub>	SCKx SOTx		-30	+30	- 20	+ 20	ns
SIN → SCK ↑ setup time	t <sub>IVSHI</sub>	SCKx SINx		50	-	30	-	ns
SCK ↑ → SIN hold time	t <sub>SHIXI</sub>	SCKx SINx		0	-	0	-	ns
SOT → SCK ↑ delay time	t <sub>SOVHI</sub>	SCKx SOTx		2tcycp - 30	-	2tcycp - 30	-	ns
Serial clock "L" pulse width	t <sub>SLSH</sub>	SCKx		2tcycp - 10	-	2tcycp - 10	-	ns
Serial clock "H" pulse width	t <sub>SHSL</sub>	SCKx	tcycp + 10	-	tcycp + 10	-	ns	
SCK ↓ → SOT delay time	t <sub>SLOVE</sub>	SCKx SOTx	External shift clock operation	-	50	-	30	ns
SIN → SCK ↑ setup time	t <sub>IVSHE</sub>	SCKx SINx		10	-	10	-	ns
SCK ↑ → SIN hold time	t <sub>SHIXE</sub>	SCKx SINx		20	-	20	-	ns
SCK fall time	t <sub>F</sub>	SCKx		-	5	-	5	ns
SCK rise time	t <sub>R</sub>	SCKx		-	5	-	5	ns

Notes: • The above characteristics apply to CLK synchronous mode.

• t<sub>CYCP</sub> indicates the APB bus clock cycle time.

About the APB bus number which UART is connected to, see "■BLOCK DIAGRAM" in this data sheet.

• These characteristics only guarantee the same relocate port number.

For example, the combination of SCLKx\_0 and SOTx\_1 is not guaranteed.

• When the external load capacitance = 30pF.

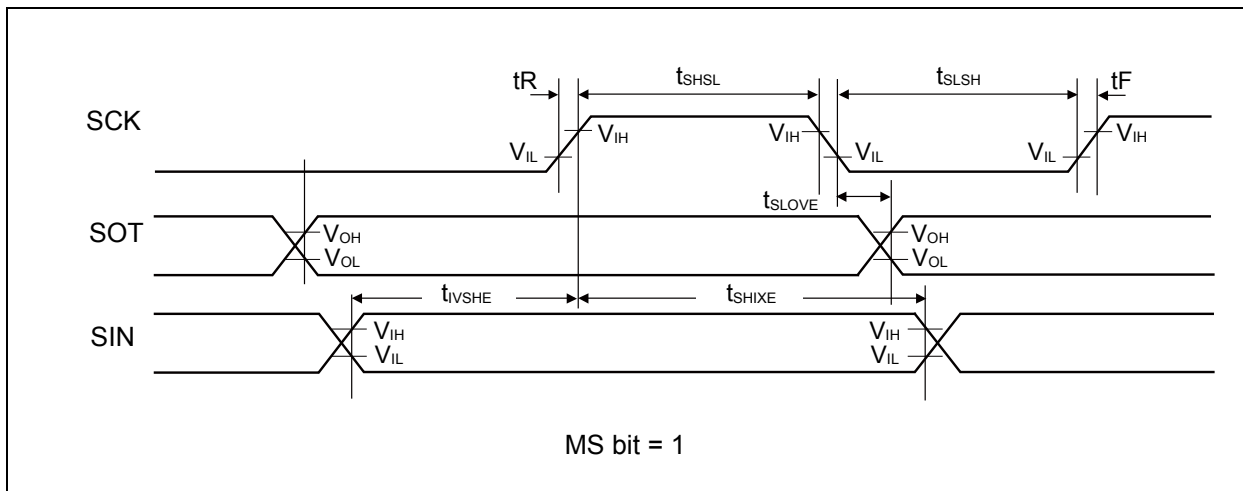
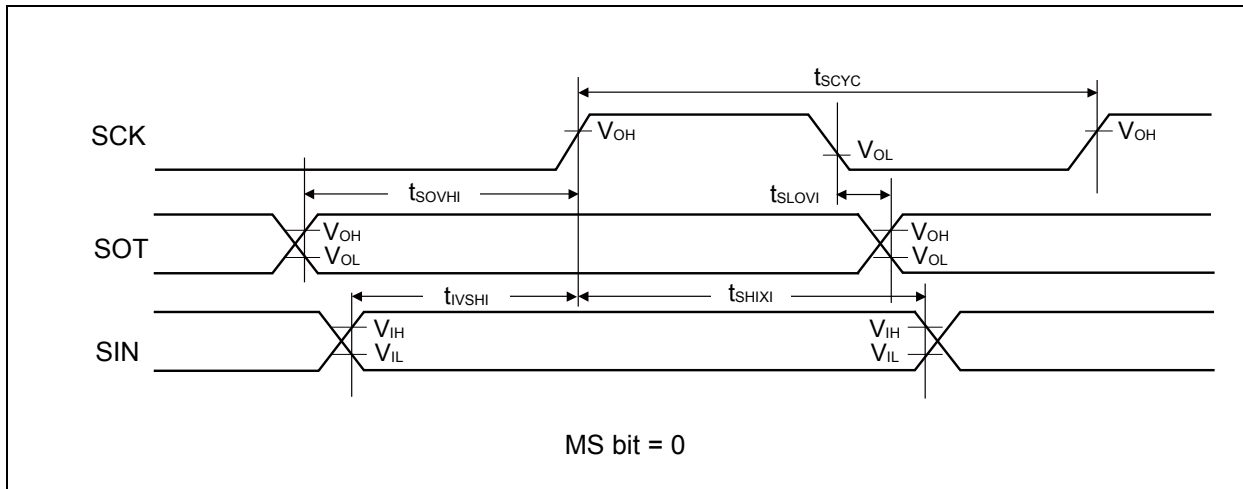

• External clock (EXT = 1) : asynchronous only

(Vcc = 2.7V to 5.5V, Vss = 0V, Ta = - 40°C to + 85°C)

Parameter	Symbol	Conditions	Value		Unit	Remarks
			Min	Max		
Serial clock "L" pulse width	$t_{SLSH}$	$C_L = 30pF$	$t_{cycp} + 10$	-	ns	
Serial clock "H" pulse width	$t_{SHSL}$		$t_{cycp} + 10$	-	ns	
SCK fall time	$t_F$		-	5	ns	
SCK rise time	$t_R$		-	5	ns	

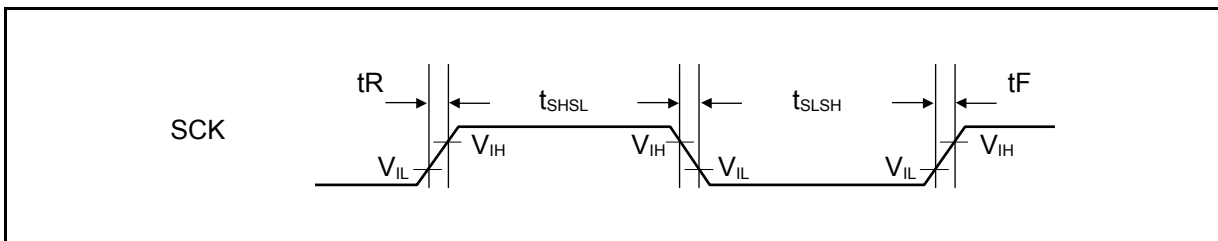

## (10) External Input Timing

(V<sub>CC</sub> = 2.7V to 5.5V, V<sub>SS</sub> = 0V, T<sub>a</sub> = - 40°C to + 85°C)

Parameter	Symbol	Pin name	Conditions	Value		Unit	Remarks
				Min	Max		
Input pulse width	t <sub>INH</sub> , t <sub>INL</sub>	ADTG	-	2t <sub>CYCP</sub> * <sup>1</sup>	-	ns	A/D converter trigger input
		FRCKx					Free-run timer input clock
		ICxx					Input capture
		DTTIxX	-	2t <sub>CYCP</sub> * <sup>1</sup>	-	ns	Wave form generator
		INT00 to INT15, NMIX	-	2t <sub>CYCP</sub> + 100* <sup>1</sup>	-	ns	External interrupt NMI
				500* <sup>2</sup>	-	ns	

\*1 : t<sub>CYCP</sub> indicates the APB bus clock cycle time except stop when in stop mode, in timer mode.

About the APB bus number which A/D converter, Multi-function Timer, External interrupt is connected to, see "■BLOCK DIAGRAM" in this data sheet.

\*2 : When in stop mode, in timer mode.

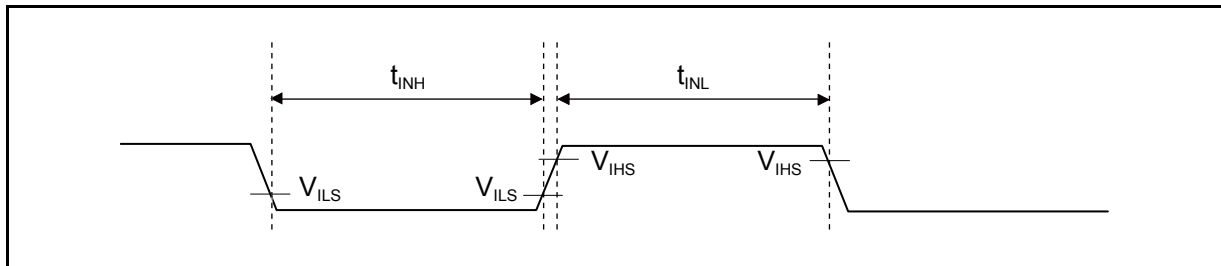

(11) Quadrature Position/Revolution Counter timing

(V<sub>CC</sub> = 2.7V to 5.5V, V<sub>SS</sub> = 0V, T<sub>a</sub> = - 40°C to + 85°C)

Parameter	Symbol	Conditions	Value		Unit
			Min	Max	
AIN pin "H" width	t <sub>AHL</sub>	-	2t <sub>CYCP</sub> *	-	ns
AIN pin "L" width	t <sub>ALL</sub>	-			
BIN pin "H" width	t <sub>BHL</sub>	-			
BIN pin "L" width	t <sub>BLL</sub>	-			
BIN rise time from AIN pin "H" level	t <sub>AUBU</sub>	PC_Mode2 or PC_Mode3			
AIN fall time from BIN pin "H" level	t <sub>BUAD</sub>	PC_Mode2 or PC_Mode3			
BIN fall time from AIN pin "L" level	t <sub>ADBD</sub>	PC_Mode2 or PC_Mode3			
AIN rise time from BIN pin "L" level	t <sub>BDAU</sub>	PC_Mode2 or PC_Mode3			
AIN rise time from BIN pin "H" level	t <sub>BUAU</sub>	PC_Mode2 or PC_Mode3			
BIN fall time from AIN pin "H" level	t <sub>AUBD</sub>	PC_Mode2 or PC_Mode3			
AIN fall time from BIN pin "L" level	t <sub>BDAD</sub>	PC_Mode2 or PC_Mode3			
BIN rise time from AIN pin "L" level	t <sub>ADBU</sub>	PC_Mode2 or PC_Mode3			
ZIN pin "H" width	t <sub>ZHL</sub>	QCR:CGSC="0"			
ZIN pin "L" width	t <sub>ZLL</sub>	QCR:CGSC="0"			
AIN/BIN rise and fall time from determined ZIN level	t <sub>ZABE</sub>	QCR:CGSC="1"			
Determined ZIN level from AIN/BIN rise and fall time	t <sub>ABEZ</sub>	QCR:CGSC="1"			

\*: t<sub>CYCP</sub> indicates the APB bus clock cycle time except stop when in stop mode, in timer mode.

About the APB bus number which Quadrature Position/Revolution Counter is connected to, see "BLOCK DIAGRAM" in this data sheet.

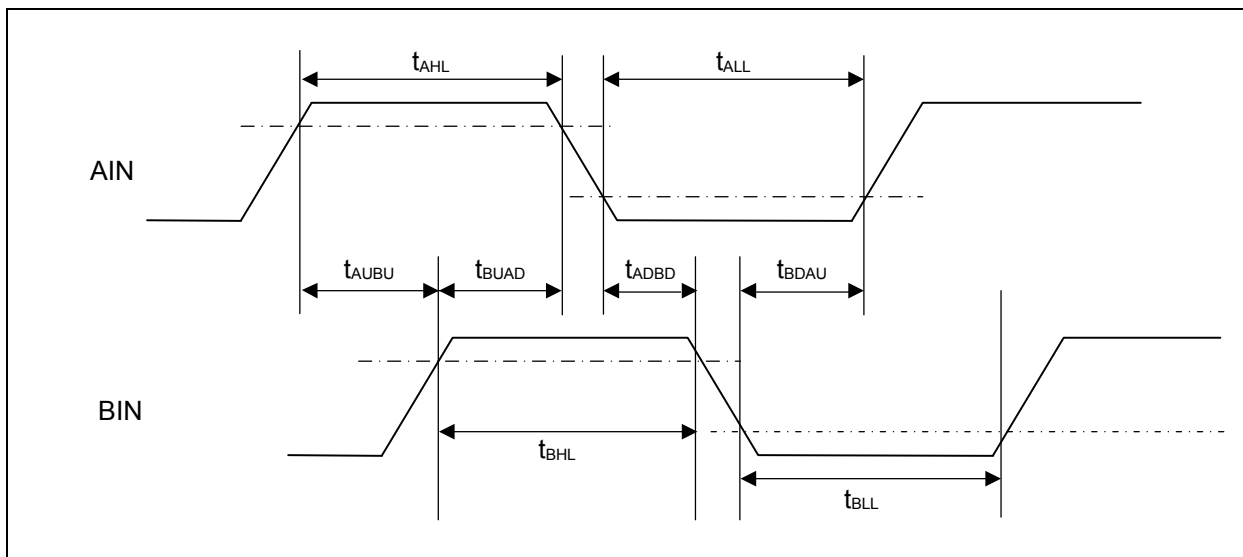

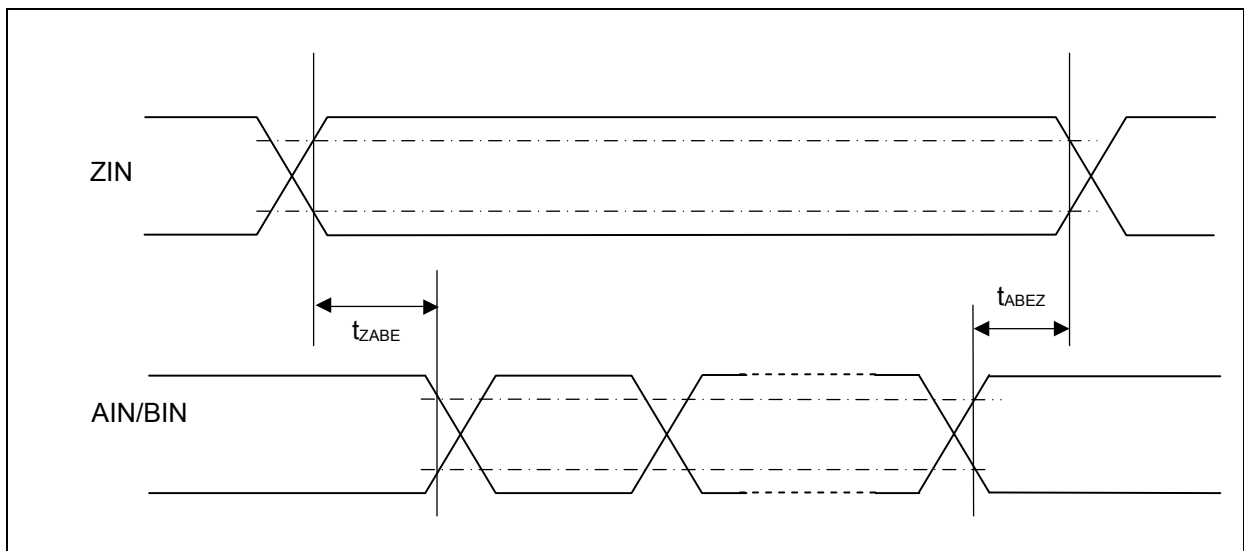
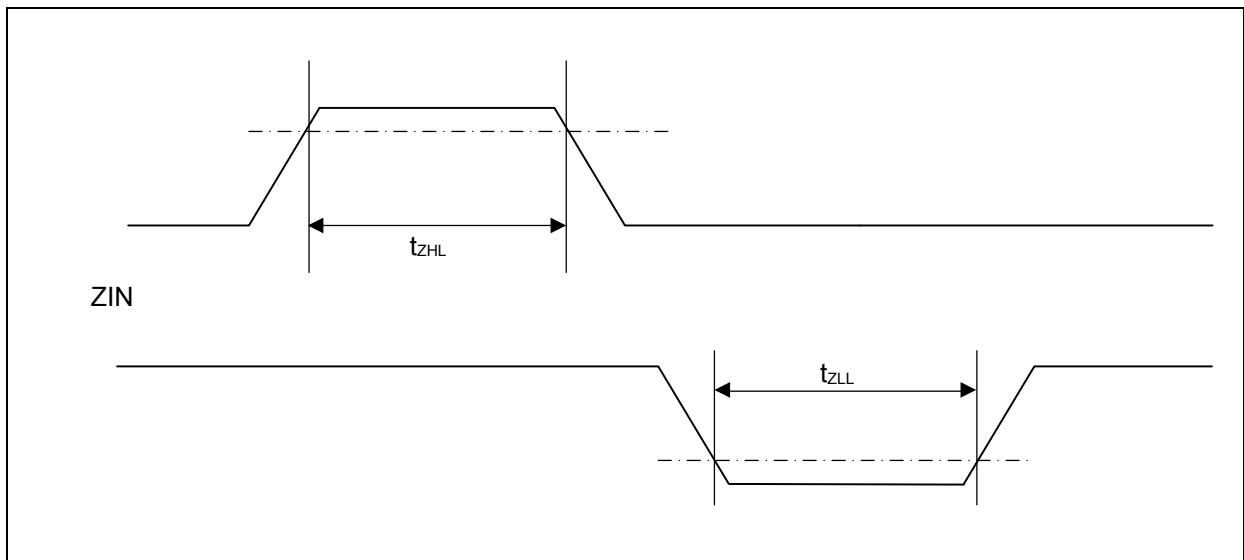
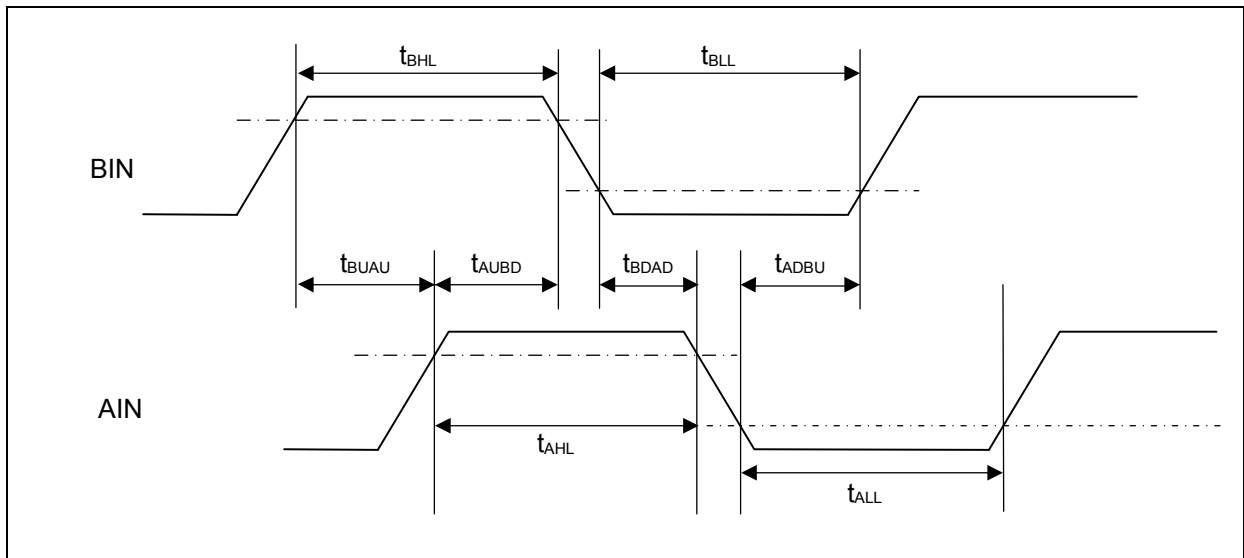



(12) I<sup>2</sup>C Timing

(V<sub>CC</sub> = 2.7V to 5.5V, V<sub>SS</sub> = 0V, T<sub>a</sub> = - 40°C to + 85°C)

Parameter	Symbol	Conditions	Typical mode		High-speed mode		Unit	Remarks
			Min	Max	Min	Max		
SCL clock frequency	f <sub>SCL</sub>	C <sub>L</sub> = 30pF, R = (V <sub>p</sub> /I <sub>OL</sub> )* <sup>1</sup>	0	100	0	400	kHz	
(Repeated) START condition hold time SDA ↓ → SCL ↓	t <sub>HDSTA</sub>		4.0	-	0.6	-	μs	
SCLclock "L" width	t <sub>LOW</sub>		4.7	-	1.3	-	μs	
SCLclock "H" width	t <sub>HIGH</sub>		4.0	-	0.6	-	μs	
(Repeated) START setup time SCL ↑ → SDA ↓	t <sub>SUSTA</sub>		4.7	-	0.6	-	μs	
Data hold time SCL ↓ → SDA ↓ ↑	t <sub>HDDAT</sub>		0	3.45* <sup>2</sup>	0	0.9* <sup>3</sup>	μs	
Data setup time SDA ↓ ↑ → SCL ↑	t <sub>SUDAT</sub>		250	-	100	-	ns	
STOP condition setup time SCL ↑ → SDA ↑	t <sub>SUSTO</sub>		4.0	-	0.6	-	μs	
Bus free time between "STOP condition" and "START condition"	t <sub>BUF</sub>		4.7	-	1.3	-	μs	
Noise filter	t <sub>SP</sub>		8MHz ≤ t <sub>CYCP</sub> ≤ 40MHz	2 t <sub>CYCP</sub> * <sup>4</sup>	-	2 t <sub>CYCP</sub> * <sup>4</sup>	-	ns
		40MHz < t <sub>CYCP</sub> ≤ 60MHz	3 t <sub>CYCP</sub> * <sup>4</sup>	-	3 t <sub>CYCP</sub> * <sup>4</sup>	-	ns	*5
		60MHz < t <sub>CYCP</sub> ≤ 72MHz	4 t <sub>CYCP</sub> * <sup>4</sup>	-	4 t <sub>CYCP</sub> * <sup>4</sup>	-	ns	*5

- \*1 : R and C represent the pull-up resistance and load capacitance of the SCL and SDA lines, respectively.  
V<sub>p</sub> indicates the power supply voltage of the pull-up resistance and I<sub>OL</sub> indicates V<sub>OL</sub> guaranteed current.
- \*2 : The maximum t<sub>HDDAT</sub> must satisfy that it does not extend at least "L" period (t<sub>LOW</sub>) of device's SCL signal.
- \*3 : A high-speed mode I<sup>2</sup>C bus device can be used on a standard mode I<sup>2</sup>C bus system as long as the device satisfies the requirement of "t<sub>SUDAT</sub> ≥ 250 ns".
- \*4 : t<sub>CYCP</sub> is the APB bus clock cycle time.  
About the APB bus number that I<sup>2</sup>C is connected to, see "■BLOCK DIAGRAM" in this data sheet.  
To use I<sup>2</sup>C, set the peripheral bus clock at 8 MHz or more.
- \*5 : The number of the steps of the noise filter can be changed by register settings.  
Change the number of the noise filter steps according to APB2 bus clock frequency.

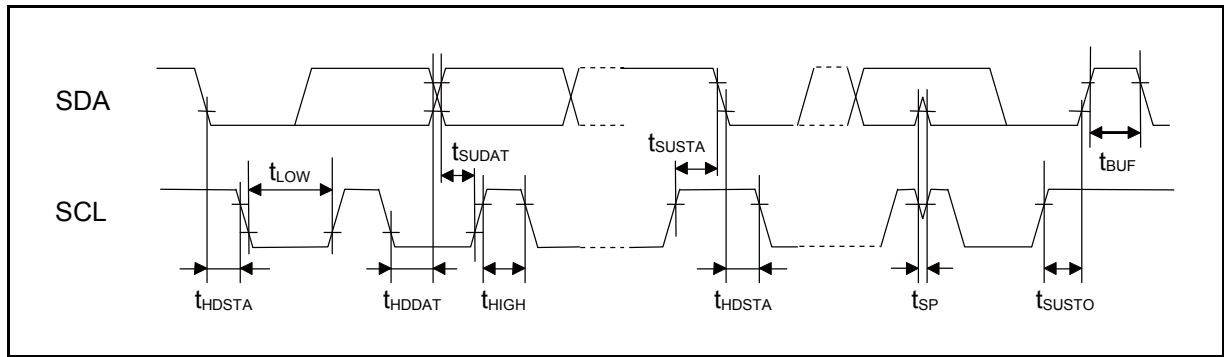

(13) ETM Timing

(Vcc = 2.7V to 5.5V, Vss = 0V, Ta = - 40°C to + 85°C)

Parameter	Symbol	Pin name	Conditions	Value		Unit	Remarks
				Min	Max		
Data hold	$t_{ETMH}$	TRACECLK TRACED[3:0]	$V_{cc} \geq 4.5V$	2	9	ns	
			$V_{cc} < 4.5V$	2	15		
TRACECLK frequency	$1/t_{TRACE}$	TRACECLK	$V_{cc} \geq 4.5V$	-	50	MHz	
			$V_{cc} < 4.5V$	-	32	MHz	
TRACECLK cycle time	$t_{TRACE}$	TRACECLK	$V_{cc} \geq 4.5V$	20	-	ns	
			$V_{cc} < 4.5V$	31.25	-	ns	

Note: When the external load capacitance = 30pF.

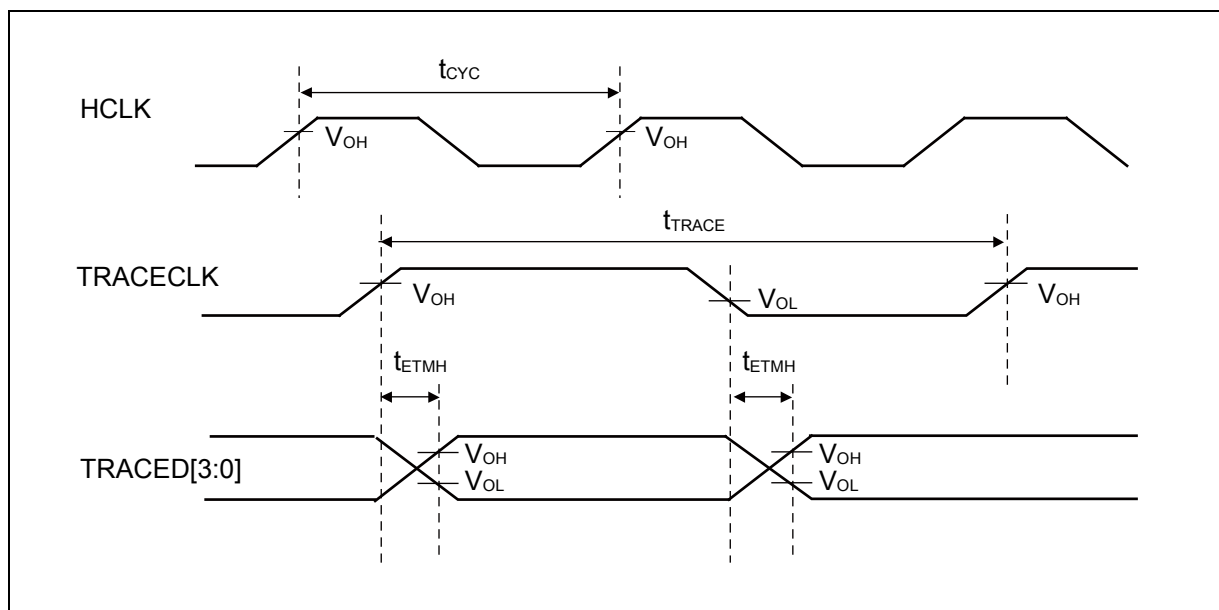

## (14) JTAG Timing

( $V_{CC} = 2.7V$  to  $5.5V$ ,  $V_{SS} = 0V$ ,  $T_a = -40^{\circ}C$  to  $+85^{\circ}C$ )

Parameter	Symbol	Pin name	Conditions	Value		Unit	Remarks
				Min	Max		
TMS, TDI setup time	$t_{JTAGS}$	TCK, TMS, TDI	$V_{CC} \geq 4.5V$	15	-	ns	
			$V_{CC} < 4.5V$				
TMS, TDI hold time	$t_{JTAGH}$	TCK, TMS, TDI	$V_{CC} \geq 4.5V$	15	-	ns	
			$V_{CC} < 4.5V$				
TDO delay time	$t_{JTAGD}$	TCK, TDO	$V_{CC} \geq 4.5V$	-	25	ns	
			$V_{CC} < 4.5V$	-	45		

Note: When the external load capacitance = 30pF.

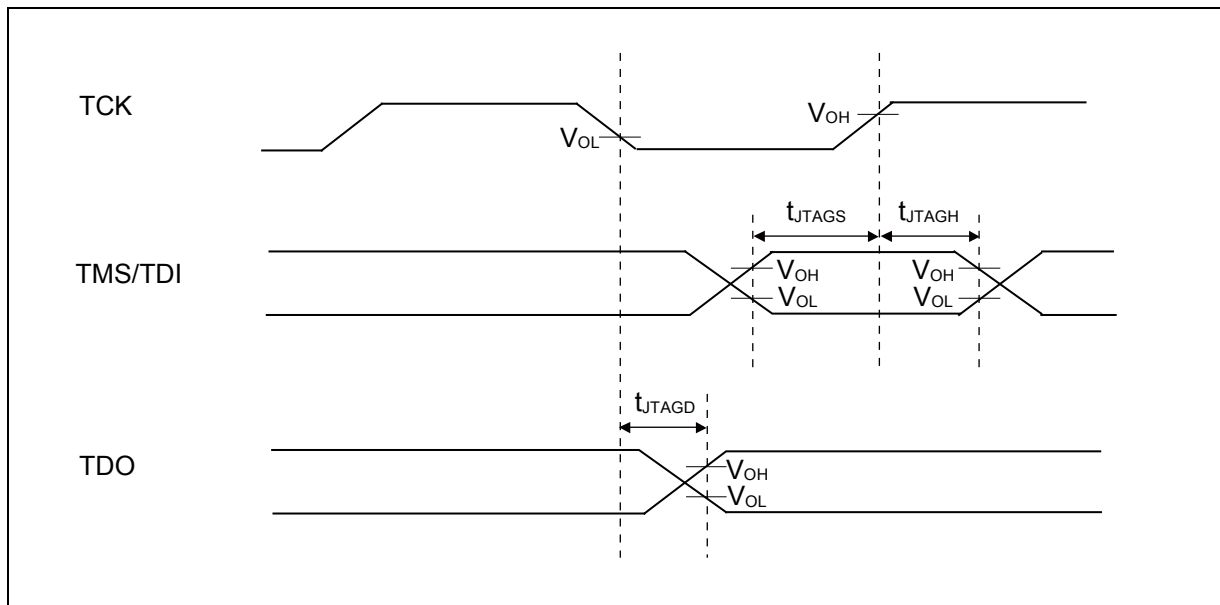

## 5. 12-bit A/D Converter

- Electrical Characteristics for the A/D Converter (Preliminary value)

( $V_{CC} = AV_{CC} = 2.7V$  to  $5.5V$ ,  $V_{SS} = AV_{SS} = 0V$ ,  $T_a = -40^{\circ}C$  to  $+85^{\circ}C$ )

Parameter	Pin name	Value			Unit	Remarks
		Min	Typ	Max		
Resolution	-	-	-	12	bit	
Linearity error	-	- 4.5	-	+ 4.5	LSB	AVRH = 2.7V to 5.5V
Differential linearity error	-	- 2.5	-	+ 2.5	LSB	
Zero transition voltage	AN0 to AN15	- 20	-	+ 20	mV	
Full-scale transition voltage	AN0 to AN15	AVRH - 20	-	AVRH + 20	mV	
Conversion time	-	1.0* <sup>1</sup>	-	-	$\mu s$	
Sampling time	Ts	*2	-	-	ns	AVCC $\geq$ 4.5V
		*2	-	-		AVCC < 4.5V
Compare clock cycle* <sup>3</sup>	Tcck	50	-	10000	ns	AVCC $\geq$ 4.5V
						AVCC < 4.5V
State transition time to operation permission	Tstt	1.0	-	-	$\mu s$	
Power supply current (analog + digital)	AVCC	-	0.47	0.62	mA	A/D 1unit operation
		-	0.06	TBD	$\mu A$	When A/D stop
Reference power supply current (between AVRH to AVSS)	AVRH	-	1.1	1.96	mA	A/D 1unit operation AVRH=5.5V
		-	0.06	TBD	$\mu A$	When A/D stop
Analog input capacity	Cin	-	-	12.9	pF	
Analog input resistance	Rin	-	-	2	k $\Omega$	AVCC $\geq$ 4.5V
				3.8		AVCC < 4.5V
Interchannel disparity	-	-	-	4	LSB	
Analog port input current	AN0 to AN15	-	-	5	$\mu A$	
Analog input voltage	AN0 to AN15	AVSS	-	AVRH	V	
Reference voltage	AVRH	AVSS	-	AVCC	V	

\*1: Conversion time is the value of sampling time (Ts) + compare time (Tc).

The condition of the minimum conversion time is when the value of sampling time:  $0.3\mu s$ , the value of sampling time:  $700ns$  (AVCC  $\geq$  4.5V).

Ensure that it satisfies the value of sampling time (Ts) and compare clock cycle (Tcck).

For setting\*<sup>4</sup> of sampling time and compare clock cycle, see "Chapter:12-bit A/D Converter" in "FM3 MB9Axxx/MB9Bxxx Series PERIPHERAL MANUAL".

A/D Converter register is set at APB bus clock timing. Sampling and compare clock is set at Base clock (HCLK).

\*2: A necessary sampling time changes by external impedance.

Ensure that it set the sampling time to satisfy (Equation 1).

\*3: Compare time (Tc) is the value of (Equation 2).

\*4: The register setting of the A/D Converter is reflected by the timing of the APB bus clock.

Sampling clock and compare clock are set in base clock (HCLK).

About the APB bus number which A/D Converter is connected to, see "■BLOCK DIAGRAM" in this data sheet.

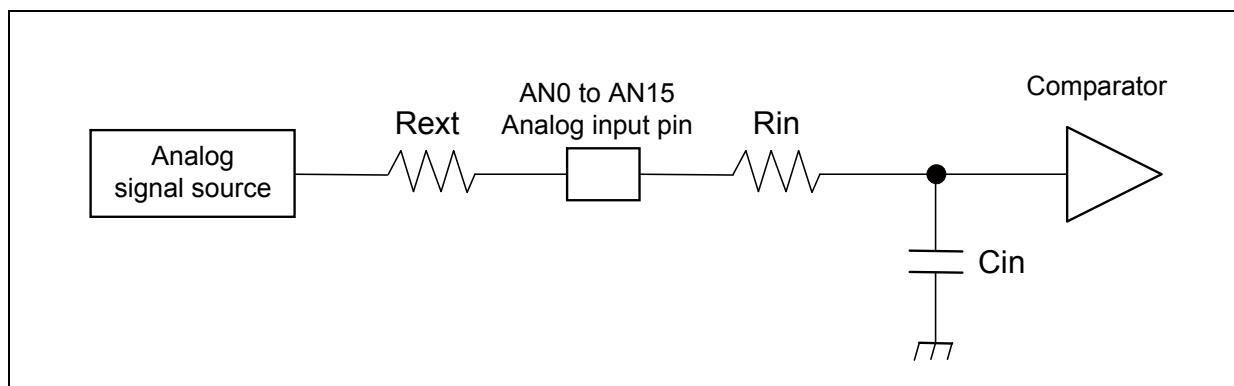

(Equation 1)  $T_s \geq (R_{in} + R_{ext}) \times C_{in} \times 9$

$T_s$  : Sampling time

$R_{in}$  : input resistance of A/D = 2k $\Omega$  at  $4.5 \leq AVCC \leq 5.5$   
input resistance of A/D = 3.8k $\Omega$  at  $2.7 \leq AVCC \leq 4.5$

$C_{in}$  : input capacity of A/D = 12.9pF at  $2.7 \leq AVCC \leq 5.5$

$R_{ext}$  : Output impedance of external circuit

(Equation 2)  $T_c = T_{cck} \times 14$

$T_c$  : Compare time

$T_{cck}$  : Compare clock cycle

• Definition of 12-bit A/D Converter Terms

- Resolution : Analog variation that is recognized by an A/D converter.
- Linearity error : Deviation of the line between the zero-transition point (0b000000000000 ↔ 0b000000000001) and the full-scale transition point (0b111111111110 ↔ 0b111111111111) from the actual conversion characteristics.
- Differential linearity error : Deviation from the ideal value of the input voltage that is required to change the output code by 1 LSB.

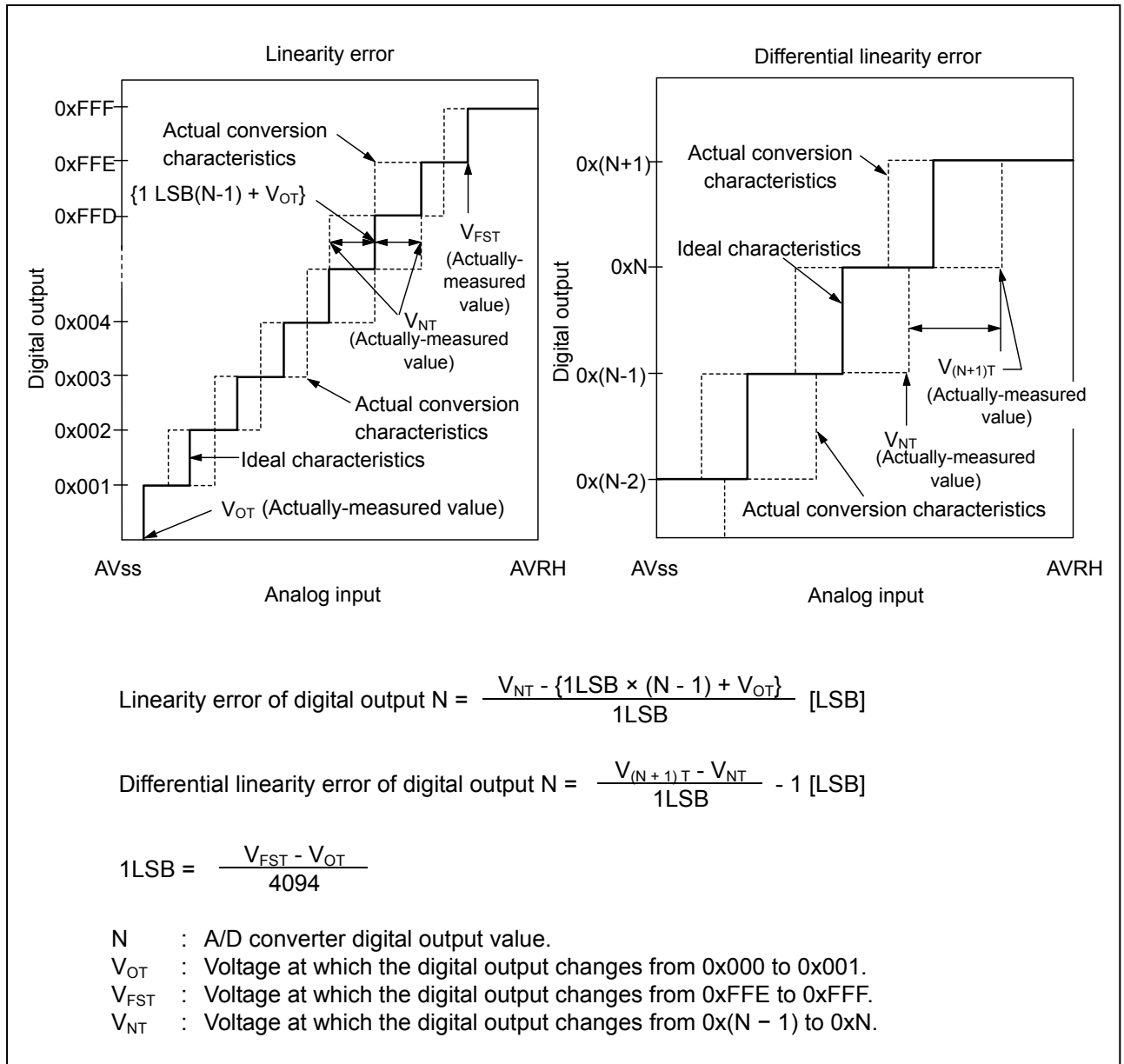

## 6. Low-Voltage Detection Characteristics

### (1) Low-Voltage Detection Reset

(Ta = - 40°C to + 85°C)

Parameter	Symbol	Conditions	Value			Unit	Remarks
			Min	Typ	Max		
Detected voltage	VDL	-	2.25	2.45	2.65	V	When voltage drops
Released voltage	VDH	-	2.30	2.50	2.70	V	When voltage rises

### (2) Interrupt of Low-Voltage Detection

(Ta = - 40°C to + 85°C)

Parameter	Symbol	Conditions	Value			Unit	Remarks
			Min	Typ	Max		
Detected voltage	VDL	SVHI = 0000	2.58	2.8	3.02	V	When voltage drops
Released voltage	VDH		2.67	2.9	3.13	V	When voltage rises
Detected voltage	VDL	SVHI = 0001	2.76	3.0	3.24	V	When voltage drops
Released voltage	VDH		2.85	3.1	3.34	V	When voltage rises
Detected voltage	VDL	SVHI = 0010	2.94	3.2	3.45	V	When voltage drops
Released voltage	VDH		3.04	3.3	3.56	V	When voltage rises
Detected voltage	VDL	SVHI = 0011	3.31	3.6	3.88	V	When voltage drops
Released voltage	VDH		3.40	3.7	3.99	V	When voltage rises
Detected voltage	VDL	SVHI = 0100	3.40	3.7	3.99	V	When voltage drops
Released voltage	VDH		3.50	3.8	4.10	V	When voltage rises
Detected voltage	VDL	SVHI = 0111	3.68	4.0	4.32	V	When voltage drops
Released voltage	VDH		3.77	4.1	4.42	V	When voltage rises
Detected voltage	VDL	SVHI = 1000	3.77	4.1	4.42	V	When voltage drops
Released voltage	VDH		3.86	4.2	4.53	V	When voltage rises
Detected voltage	VDL	SVHI = 1001	3.86	4.2	4.53	V	When voltage drops
Released voltage	VDH		3.96	4.3	4.64	V	When voltage rises
LVD stabilization wait time	T <sub>LVDW</sub>	-	-	-	2240 × tcycp*	μs	

\*: tcycp indicates the APB2 bus clock cycle time.



7. MainFlash Memory Write/Erase Characteristics

(Vcc = 2.7V to 5.5V, Ta = - 40°C to + 85°C)

Parameter		Value			Unit	Remarks
		Min	Typ	Max		
Sector erase time	Large Sector	-	0.7	3.7	s	Includes write time prior to internal erase
	Small Sector		0.3	1.1		
Half word (16-bit) write time		-	12	384	μs	Not including system-level overhead time
Chip erase time		-	8	38.4	s	Includes write time prior to internal erase

Erase/write cycles and data hold time (targeted value)

Erase/write cycles (cycle)	Data hold time (year)	Remarks
1,000	20*	
10,000	10*	
100,000	5*	

\*: This value comes from the technology qualification (using Arrhenius equation to translate high temperature measurements into normalized value at + 85°C) .

8. WorkFlash Memory Write/Erase Characteristics (Preliminary value)

(Vcc = 2.7V to 5.5V, Ta = - 40°C to + 85°C)

Parameter		Value			Unit	Remarks
		Min	Typ	Max		
Sector erase time	Large Sector	-	0.7	3.7	s	Includes write time prior to internal erase
	Small Sector		0.3	1.1		
Half word (16-bit) write time		-	12	384	μs	Not including system-level overhead time
Chip erase time		-	1.2	6	s	Includes write time prior to internal erase

Erase/write cycles and data hold time (targeted value)

Erase/write cycles (cycle)	Data hold time (year)	Remarks
1,000	20*	
10,000	10*	

\*: This value comes from the technology qualification (using Arrhenius equation to translate high temperature measurements into normalized value at + 85°C) .

## ■ ORDERING INFORMATION

Part number	Package
MB9BF112NPF	Plastic • QFP 100-pin (0.65mm pitch), (FPT-100P-M36)
MB9BF114NPF	
MB9BF115NPF	
MB9BF116NPF	
MB9BF112NPMC	Plastic • LQFP 100-pin (0.5mm pitch), (FPT-100P-M20*/M23)
MB9BF114NPMC	
MB9BF115NPMC	
MB9BF116NPMC	
MB9BF112RPMC	Plastic • LQFP 120-pin (0.5mm pitch), (FPT-120P-M21*/M37)
MB9BF114RPMC	
MB9BF115RPMC	
MB9BF116RPMC	
MB9BF112NBGL	Plastic • PFBGA 112-pin (0.8mm pitch), (BGA-112P-M04)
MB9BF114NBGL	
MB9BF115NBGL	
MB9BF116NBGL	

\* : ES product only

■ PACKAGE DIMENSIONS

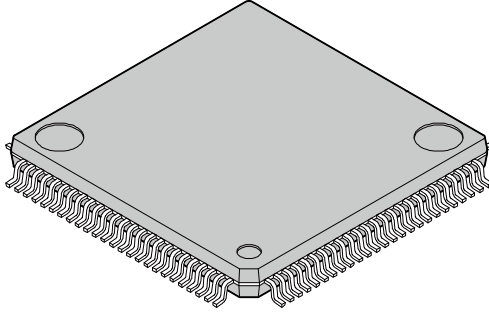
 <p>100-pin plastic LQFP</p> <p>(FPT-100P-M20)</p>	Lead pitch	0.50 mm
	Package width × package length	14.0 mm × 14.0 mm
	Lead shape	Gullwing
	Sealing method	Plastic mold
	Mounting height	1.70 mm Max
	Weight	0.65 g
	Code (Reference)	P-LFQFP100-14×14-0.50

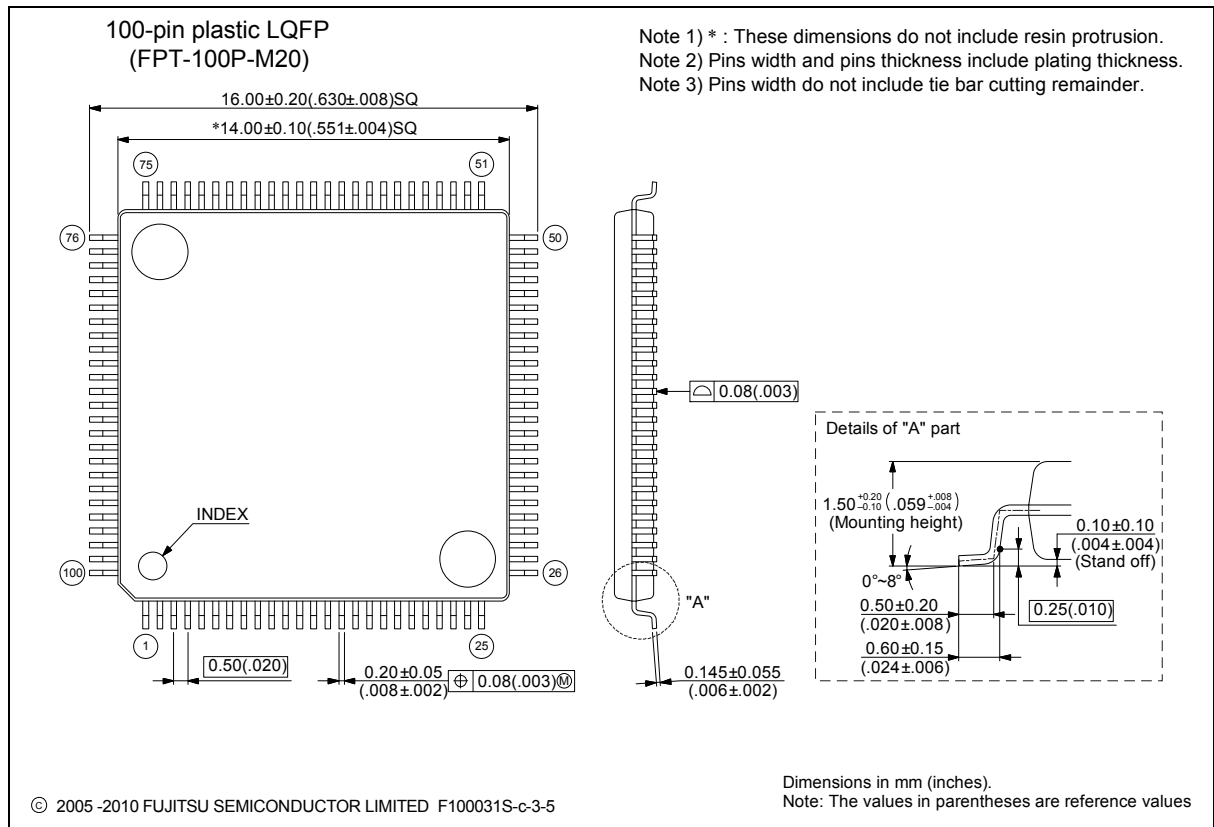

Please check the latest package dimension at the following URL.  
<http://edevice.fujitsu.com/package/en-search/>

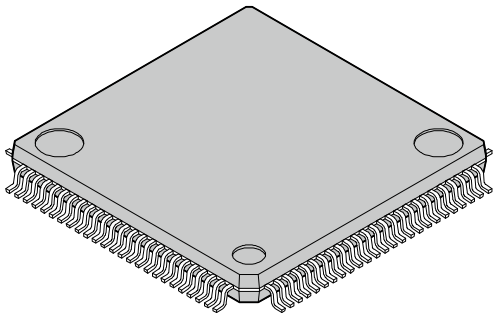
<p>100-pin plastic LQFP</p>  <p>(FPT-100P-M23)</p>	Lead pitch	0.50 mm
	Package width × package length	14.00 mm × 14.00 mm
	Lead shape	Gullwing
	Lead bend direction	Normal bend
	Sealing method	Plastic mold
	Mounting height	1.70 mm MAX
	Weight	0.65 g

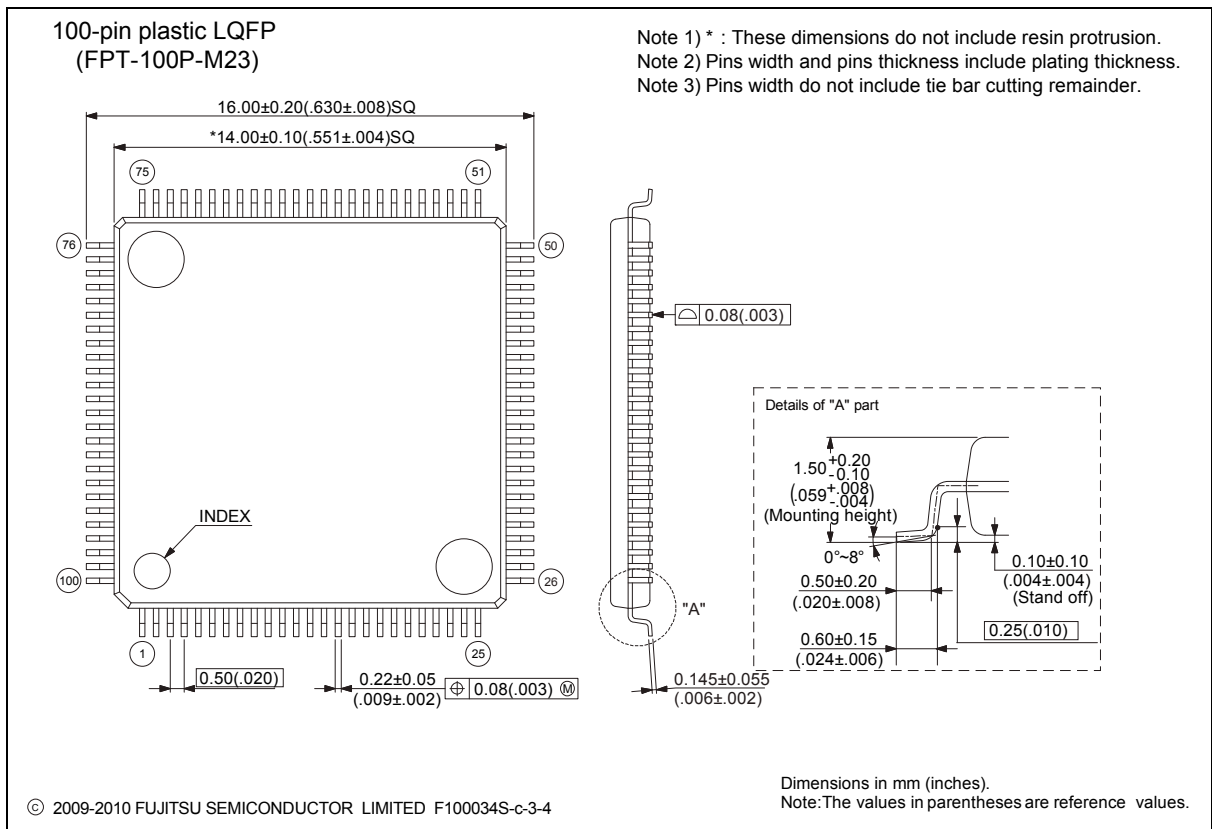

Please check the latest package dimension at the following URL.  
<http://edevic.fujitsu.com/package/en-search/>

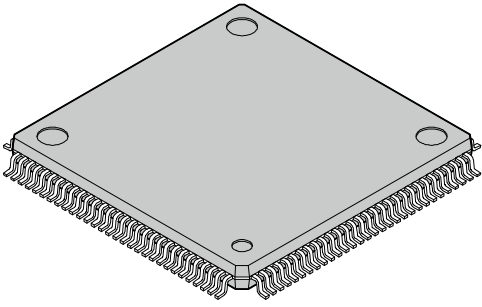
<p>120-pin plastic LQFP</p>  <p>(FPT-120P-M21)</p>	Lead pitch	0.50 mm
	Package width × package length	16.0 × 16.0 mm
	Lead shape	Gullwing
	Sealing method	Plastic mold
	Mounting height	1.70 mm MAX
	Weight	0.88 g
	Code (Reference)	P-LFQFP120-16×16-0.50

120-pin plastic LQFP (FPT-120P-M21)

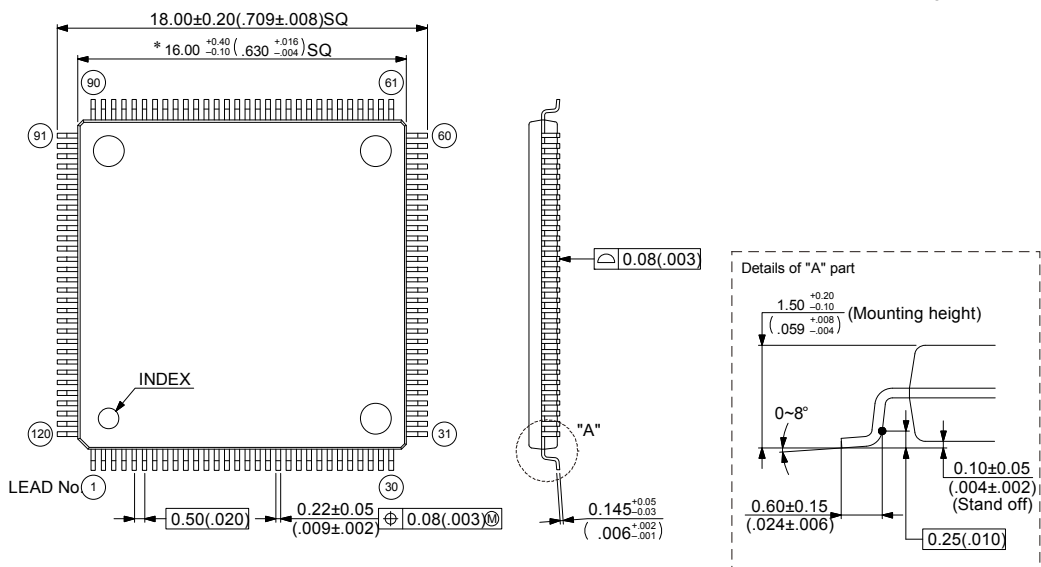

Note 1) \* : These dimensions do not include resin protrusion. Resin protrusion is +0.25(.010) MAX(each side).  
 Note 2) Pins width and pins thickness include plating thickness.  
 Note 3) Pins width do not include tie bar cutting remainder.

© 2002-2010 FUJITSU SEMICONDUCTOR LIMITED F120033S-c-4-7

Dimensions in mm (inches).  
 Note: The values in parentheses are reference values.

Please check the latest package dimension at the following URL.  
<http://edevice.fujitsu.com/package/en-search/>

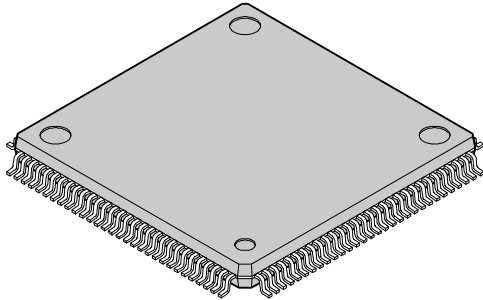
<p style="text-align: center;">120-pin plastic LQFP</p>  <p style="text-align: center;">(FPT-120P-M37)</p>	Lead pitch	0.50 mm
	Package width × package length	16.0 mm × 16.0 mm
	Lead shape	Gullwing
	Sealing method	Plastic mold
	Mounting height	1.70 mm Max
	Weight	0.88 g
	Code (Reference)	P-LFQFP120-16 × 16-0.50

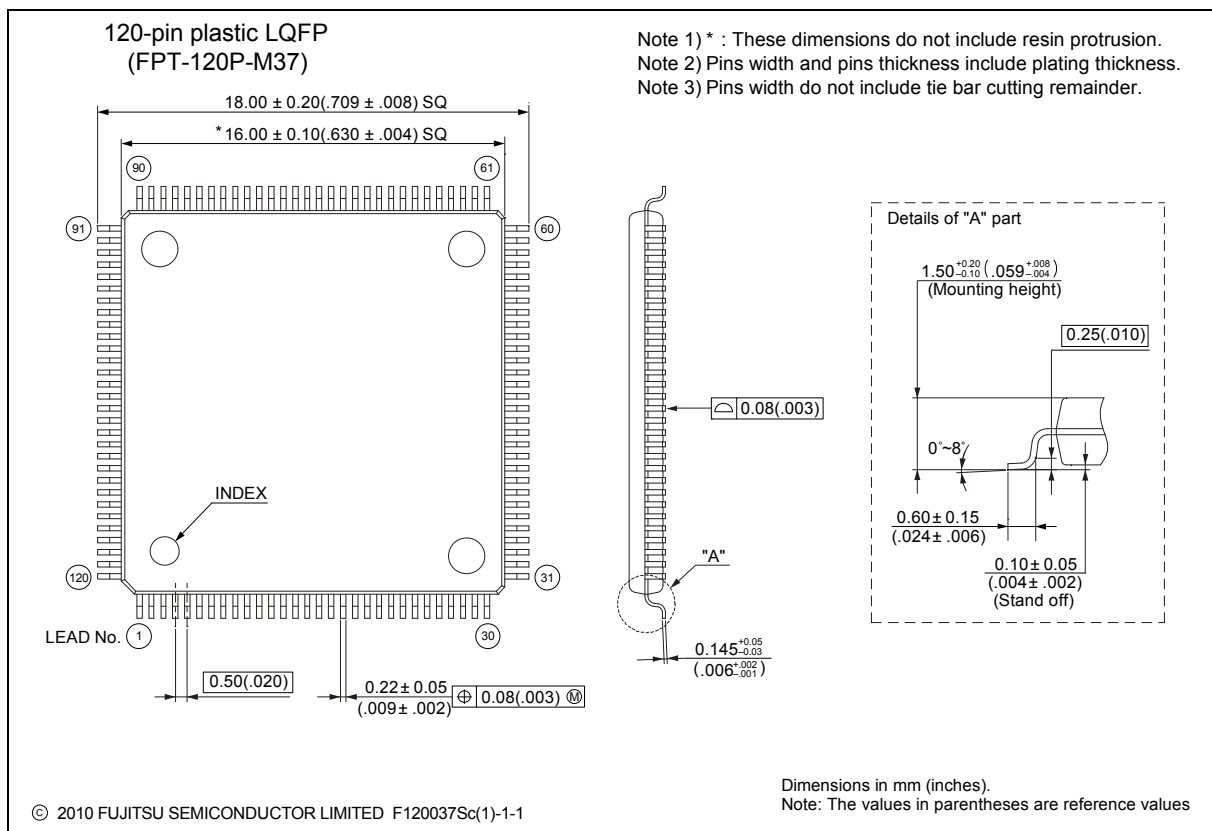

Please check the latest package dimension at the following URL.  
<http://edevice.fujitsu.com/package/en-search/>

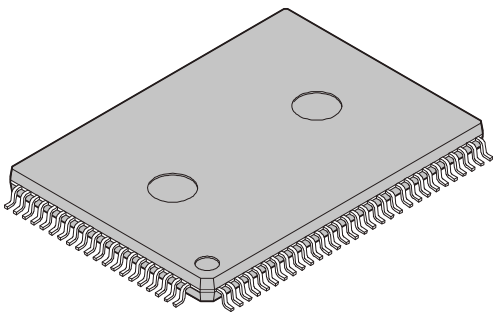
<p>100-pin plastic QFP</p>  <p>(FPT-100P-M36)</p>	Lead pitch	0.65 mm
	Package width × package length	14.00 mm × 20.00 mm
	Lead shape	Gullwing
	Sealing method	Plastic mold
	Mounting height	3.35 mm MAX
	Code (Reference)	P-QFP100-14 × 20-0.65

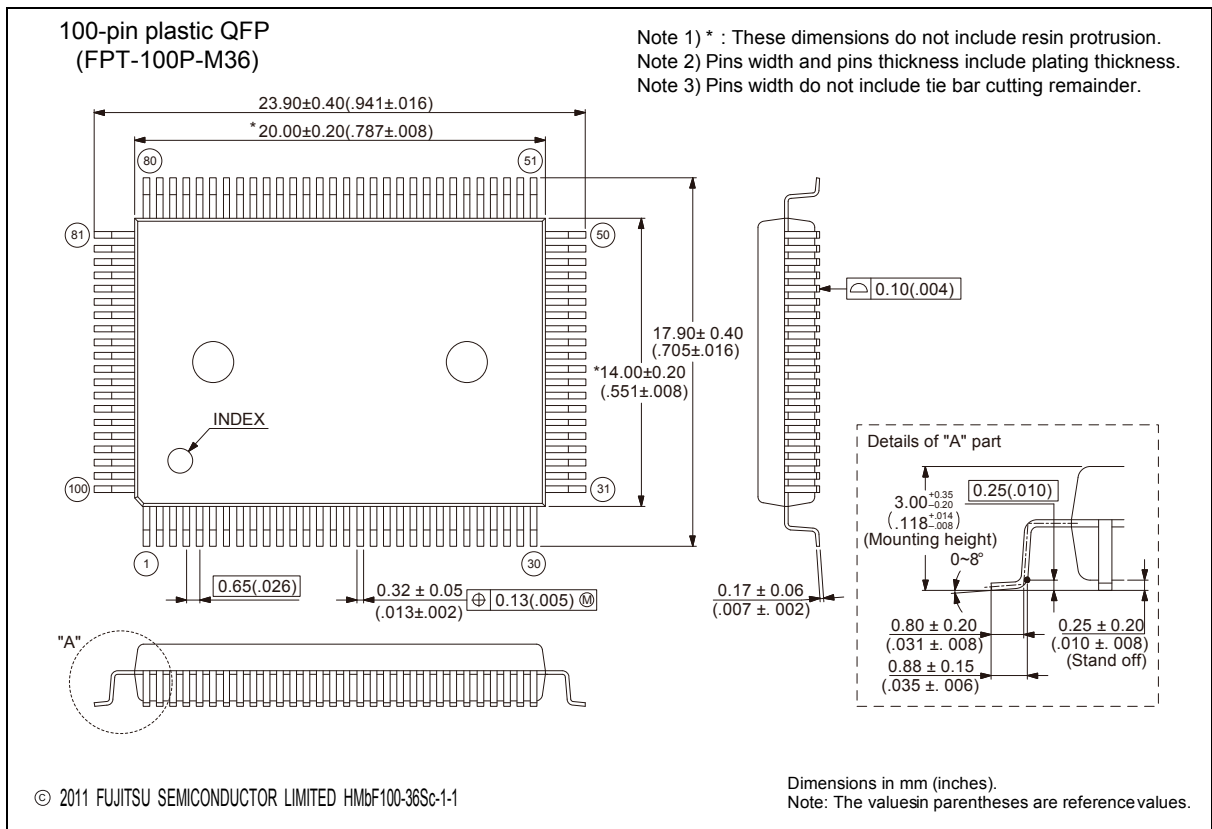

Please check the latest package dimension at the following URL.  
<http://edevice.fujitsu.com/package/en-search/>

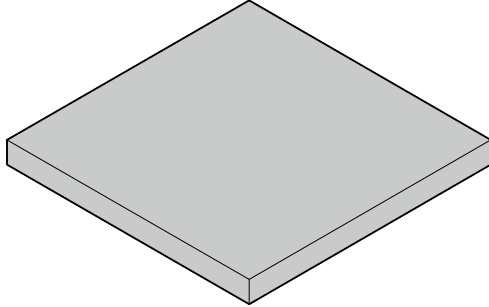
<p style="text-align: center;">112-ball plastic PFBGA</p>  <p style="text-align: center;">(BGA-112P-M04)</p>	Ball pitch	0.80 mm
	Package width × package length	10.00 × 10.00 mm
	Lead shape	Soldering ball
	Sealing method	Plastic mold
	Ball size	Φ 0.45 mm
	Mounting height	1.45 mm Max.
	Weight	0.22 g

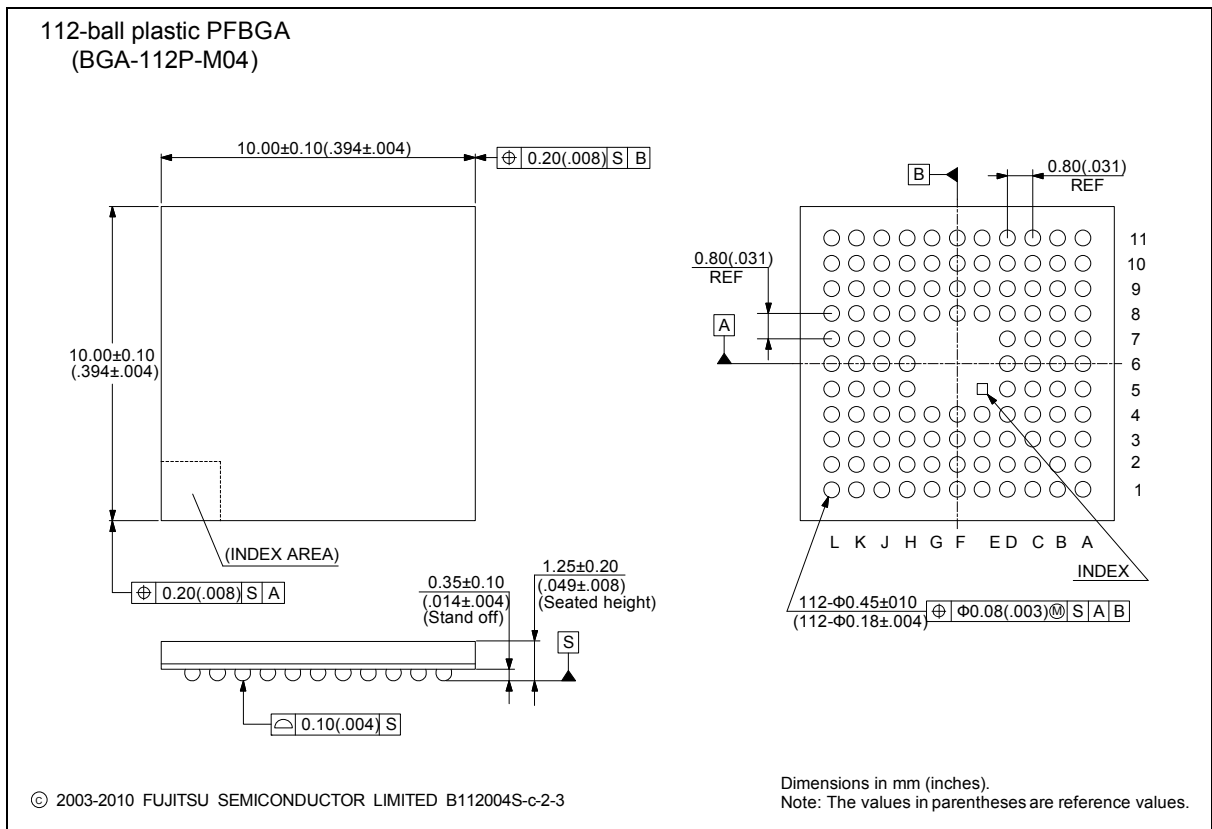

Please check the latest package dimension at the following URL.  
<http://edevic.fujitsu.com/package/en-search/>



**MEMO**

**MEMO**

**MEMO**

## FUJITSU SEMICONDUCTOR LIMITED

Nomura Fudosan Shin-yokohama Bldg. 10-23, Shin-yokohama 2-Chome,  
Kohoku-ku Yokohama Kanagawa 222-0033, Japan

Tel: +81-45-415-5858

<http://jp.fujitsu.com/fsl/en/>

*For further information please contact:*

### North and South America

FUJITSU SEMICONDUCTOR AMERICA, INC.

1250 E. Arques Avenue, M/S 333

Sunnyvale, CA 94085-5401, U.S.A.

Tel: +1-408-737-5600 Fax: +1-408-737-5999

<http://us.fujitsu.com/micro/>

### Asia Pacific

FUJITSU SEMICONDUCTOR ASIA PTE. LTD.

151 Lorong Chuan,

#05-08 New Tech Park 556741 Singapore

Tel : +65-6281-0770 Fax : +65-6281-0220

<http://sg.fujitsu.com/semiconductor/>

### Europe

FUJITSU SEMICONDUCTOR EUROPE GmbH

Pittlerstrasse 47, 63225 Langen, Germany

Tel: +49-6103-690-0 Fax: +49-6103-690-122

<http://emea.fujitsu.com/semiconductor/>

FUJITSU SEMICONDUCTOR SHANGHAI CO., LTD.

30F, Kerry Parkside, 1155 Fang Dian Road,

Pudong District, Shanghai 201204, China

Tel : +86-21-6146-3688 Fax : +86-21-6146-3660

<http://cn.fujitsu.com/fss/>

### Korea

FUJITSU SEMICONDUCTOR KOREA LTD.

902 Kosmo Tower Building, 1002 Daechi-Dong,

Gangnam-Gu, Seoul 135-280, Republic of Korea

Tel: +82-2-3484-7100 Fax: +82-2-3484-7111

<http://kr.fujitsu.com/fsk/>

FUJITSU SEMICONDUCTOR PACIFIC ASIA LTD.

10/F., World Commerce Centre, 11 Canton Road,

Tsimshatsui, Kowloon, Hong Kong

Tel : +852-2377-0226 Fax : +852-2376-3269

<http://cn.fujitsu.com/fsp/>

Specifications are subject to change without notice. For further information please contact each office.

### All Rights Reserved.

The contents of this document are subject to change without notice.

Customers are advised to consult with sales representatives before ordering.

The information, such as descriptions of function and application circuit examples, in this document are presented solely for the purpose of reference to show examples of operations and uses of FUJITSU SEMICONDUCTOR device; FUJITSU SEMICONDUCTOR does not warrant proper operation of the device with respect to use based on such information. When you develop equipment incorporating the device based on such information, you must assume any responsibility arising out of such use of the information.

FUJITSU SEMICONDUCTOR assumes no liability for any damages whatsoever arising out of the use of the information.

Any information in this document, including descriptions of function and schematic diagrams, shall not be construed as license of the use or exercise of any intellectual property right, such as patent right or copyright, or any other right of FUJITSU SEMICONDUCTOR or any third party or does FUJITSU SEMICONDUCTOR warrant non-infringement of any third-party's intellectual property right or other right by using such information. FUJITSU SEMICONDUCTOR assumes no liability for any infringement of the intellectual property rights or other rights of third parties which would result from the use of information contained herein.

The products described in this document are designed, developed and manufactured as contemplated for general use, including without limitation, ordinary industrial use, general office use, personal use, and household use, but are not designed, developed and manufactured as contemplated (1) for use accompanying fatal risks or dangers that, unless extremely high safety is secured, could have a serious effect to the public, and could lead directly to death, personal injury, severe physical damage or other loss (i.e., nuclear reaction control in nuclear facility, aircraft flight control, air traffic control, mass transport control, medical life support system, missile launch control in weapon system), or (2) for use requiring extremely high reliability (i.e., submersible repeater and artificial satellite).

Please note that FUJITSU SEMICONDUCTOR will not be liable against you and/or any third party for any claims or damages arising in connection with above-mentioned uses of the products.

Any semiconductor devices have an inherent chance of failure. You must protect against injury, damage or loss from such failures by incorporating safety design measures into your facility and equipment such as redundancy, fire protection, and prevention of over-current levels and other abnormal operating conditions.

Exportation/release of any products described in this document may require necessary procedures in accordance with the regulations of the Foreign Exchange and Foreign Trade Control Law of Japan and/or US export control laws.

The company names and brand names herein are the trademarks or registered trademarks of their respective owners.

Edited: Sales Promotion Department

## **X-ON Electronics**

Largest Supplier of Electrical and Electronic Components

*Click to view similar products for [Fujitsu manufacturer](#):*

Other Similar products are found below :

[FCN-363J008](#) [MAT4Z-DR](#) [FCN-268M024-G/1D](#) [FTP-639USL202](#) [FTR-K3AB012W](#) [PZ-2A2415](#) [PZ-2A2425](#) [PZ-2A2430](#) [PZ-2A2445](#) [PZ-4A2620](#) [PZ-4A2650](#) [PZ-6A2805](#) [PZ-6A2810](#) [PZ-6A2830](#) [PZ-6A2840](#) [GZ-12C](#) [GZ-12W](#) [GZ-18H](#) [GZ-9H](#) [AL-24W-K](#) [DZ4E-12V](#) [ITT2B-EH](#) [ITT2-BR](#) [25A04C24C](#) [25A04C28C](#) [RY-48W-K](#) [RY-5WZ-K](#) [26A06C54E](#) [RZ-24C](#) [RZ-2G5](#) [RZ-48C](#) [RZ-5WC](#) [RZ-6](#) [RZ-6W](#) [FTP-622CT001](#) [FTR-K1CK012W-KW](#) [24A02C81E](#) [24A12C24C](#) [24A12C61E](#) [25A04C14E](#) [25A14C09C](#) [25A14C20C](#) [26A06C08C](#) [26A06C24C](#) [26A16C11E](#) [26A16C23F](#) [GZ-3](#) [PZ-2A2412](#) [PZ-2L1D](#) [PZ-6A2800](#)