



32-bit Microcontrollers

Qorivva MPC564xA Family

32-bit MCUs for transmission applications

Target Applications

- Transmission control for 5+ speed automatic transmissions, continual variable transmissions (CVT), dual clutch and automated manual transmissions
- Engine control for 4 to 6 cylinder gasoline direct injection and direct diesel injection engines
- Multi-point fuel injection control
- Wide range of vehicles, from mid-size cars to large construction equipment

Overview

The Qorivva MPC564xA microcontroller delivers the performance and precision needed for next-generation transmission control and engine management needs. Designed with the e200z4 dual-issue core built on Power Architecture® technology, the Qorivva MPC564xA can process two instructions per clock cycle, enabling it to run more instructions per cycle and with higher performance than single-issue cores at the same MHz. Consequently, when running at the same performance level as a single-core device, it uses less power. The Qorivva MPC564xA supports up to 300 DMIPS performance while maintaining the low power required for high-temperature applications, such as transmissions.

Qorivva MPC564xA Block Diagram

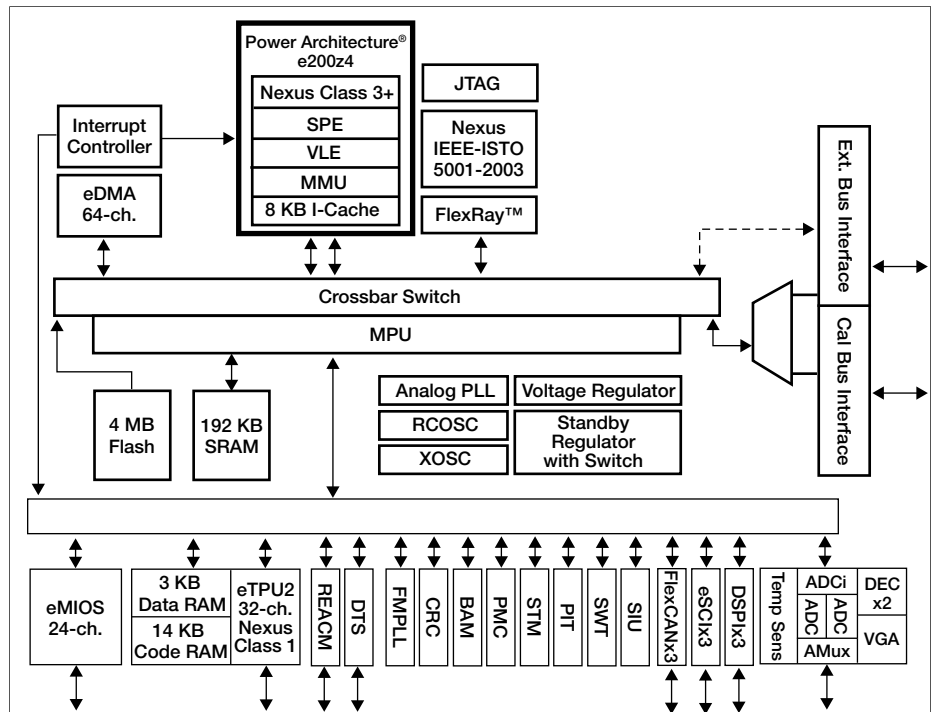

The Qorivva MPC564xA's key features include a z4 core up to 150 MHz DSP capability, up to 4 MB of flash memory, 8 KB instruction cache, up to 192 KB SRAM, 32-channel eTPU2, optional FlexRay™ and on-board knock detection. This unique set of features makes the Qorivva MPC564xA ideal for lowering overall system cost, optimizing fuel economy, reducing emissions and improving shift control.

The e200z4 core host processor is 100 percent user-mode compatible with the classic Power Architecture instruction set. The Qorivva MPC564xA also offers pin, peripheral and tool compatibility with the 32-bit Qorivva MPC563xM devices to support design flexibility across architectures. Three package options allow developers to design applications that require different amounts of I/O.

Package Options

Part Number	Temp Ranges (Ta)	Package
PPC5644AMVZ150	-40°C to +125°C	324 TEPBGA
PPC5644AMMG150	-40°C to +125°C	208 MAPBGA
PPC5644AMLU150	-40°C to +125°C	176 LQFP

Development Tools

Kit	Package
XPC564AKIT324S	324 TEPBGA (Pb-free)
*XPC563MKIT208S	208 MAPBGA (Pb-free)
XPC564AKIT176S	176 LQFP (Pb-free)

Note: EVB kit comes with motherboard and adapter

* MPC564xA is pin compatible with MPC563xM, hence they share the same tool kit in 208MAP and 176QFP package configuration.

Qorivva MPC564xA Product Family

Product	Performance	Flash	SRAM	Communication	Timers	ADC	Package
MPC5644A	80 MHz–150 MHz	4 MB	192 KB	2-ch. FlexRay 3-ch. FlexCAN	32-ch. eTPU 24-ch. eMIOS	Up to 40-ch. 12-bit	324 TEPBGA 208 MAPBGA 176 LQFP
MPC5643A	80 MHz–150 MHz	3 MB	192 KB	2-ch. FlexRay 3-ch. FlexCAN	32-ch. eTPU 24-ch. eMIOS	Up to 40-ch. 12-bit	324 TEPBGA 208 MAPBGA 176 LQFP
MPC5642A	80 MHz–150 MHz	2 MB	128 KB	2-ch. FlexRay 3-ch. FlexCAN	32-ch. eTPU 24-ch. eMIOS	Up to 40-ch. 12-bit	324 TEPBGA 208 MAPBGA 176 LQFP

System Challenges

Qorivva MPC564xA Solution

Transmission Control System Challenges

Support large calibration data sets and complex algorithms for precision tuning to reduce emissions and improve fuel economy.	<ul style="list-style-type: none"> Up to 4 MB flash increases design flexibility and permits multiple calibration data sets for ECU configuration during vehicle assembly. FlexRay controller adds an additional high-speed communication channel for increased bandwidth and diagnostic reporting capability. z4 dual-issue core delivers greater than 300 MIPS of computing power to quickly perform calculations.
Transmission temperature environment requires low power to performance ratio.	<ul style="list-style-type: none"> High-performance z4 dual-issue core enables the MCU to execute two instructions simultaneously, which lowers operating frequency and reduces power consumption. On-board junction temperature sensor monitors temperature through an analog-to-digital conversion, alerting the system if a high-temperature situation occurs.
Current control of solenoids have a large presence in transmission applications. Existing solutions require custom ASIC devices to provide this functionality, however these have an associated system cost and offer limited flexibility.	<ul style="list-style-type: none"> The Reaction Module on the Qorivva MPC564xA performs closed loop current control of up to three outputs per channel, potentially providing control to 18 solenoids, with zero CPU loading. The flexibility of this module allows complex current waveforms to be created, such as dither, to meet the needs of a transmission application. This highly flexible feature can also reduce system cost by removing external ASICs, and replacing it with standard FET drivers.

Engine Control Challenges

Requires very complex calculations to: <ol style="list-style-type: none"> Provide precise combustion control Run model-based strategies and autocode with multiple spark and fuel pulses Optimize variable cam timing and exhaust gas recirculation (EGR) to achieve greater efficiency, lower emissions, eliminate knocking and reduce carcinogenic particulate matter in direct injection engines 	<ul style="list-style-type: none"> z4 dual-issue core delivers greater than 300 MIPS (150 MHz) of computing power to efficiently perform calculations. 192 KB SRAM offers large amounts of accessible memory to store calculation results. eTPU2 is a programmable 32-bit RISC micro capable of performing complex timing and I/O management independently of the CPU.
Requires the ability to detect and correct for engine knock in order to reduce emissions and optimize fuel economy.	<p>The Qorivva MPC564xA is designed to work with the ECU to detect and correct knock by digitizing accelerometer (sound) inputs and filtering out frequencies of interest using fully parameterized hardware DSP filters. Resulting data is used to determine if knock is occurring, at which point the system compensates spark timing and injector pulse widths accordingly.</p> <ul style="list-style-type: none"> On-chip knock detection features, such as variable gain amplifiers, dual analog-to-digital converters and hardware DSP filters, hardware integrators, work in conjunction to minimize CPU loading and reduce system cost through elimination of external components. Additional complex filtering, such as FFT, may be performed on the data using the on-board DSP capabilities of the software signal processing engine (SPE) which is built into the z4 dual-issue core. Integrated sensor bias and a patented on-board diagnostic (OBD) test algorithm verify that sensors are active and functioning properly. z4 dual-issue core delivers greater than 300 MIPS of computing power to quickly perform calculations. 192 KB SRAM offers large amounts of accessible memory to store calculation results. eTPU2 is a programmable 32-bit RISC micro capable of performing complex timing and I/O management independently of the CPU.
To meet tightening emission regulations, complex closed loop current control is required to drive injectors. This is typically performed using an external ASIC device, which has an associated component and board cost, whilst potentially offering limited flexibility for the future.	<ul style="list-style-type: none"> The Reaction Module on the Qorivva MPC564xA performs closed loop current control of up to three outputs per channel to create complex current waveforms with zero CPU loading. This highly flexible feature removes the requirement for an external ASIC, replacing it with standard FET drivers, whilst offering flexibility for the future.

Learn More: For current information about Freescale Qorivva products and documentation, please visit freescale.com/Qorivva.



Freescale, the Freescale logo and CodeWarrior are trademarks of Freescale Semiconductor, Inc., Reg. U.S. Pat. & Tm. Off. Qorivva is a trademark of Freescale Semiconductor, Inc. The Power Architecture and Power.org word marks and the Power and Power.org logos and related marks are trademarks and service marks licensed by Power.org. All other product or service names are the property of their respective owners. © 2005, 2010 Freescale Semiconductor, Inc.

Document Number: MPC564xA FS REV 1



X-ON Electronics

Largest Supplier of Electrical and Electronic Components

Click to view similar products for [NXP manufacturer](#):

Other Similar products are found below :

[74HC4538N,652](#) [74HC221D,652](#) [P2020COME-DS-PB](#) [FRDM-K28F](#) [OM13043,598](#) [OM6716,599](#) [MPC7410THX450NE](#)
[LPC1788FBD208,551](#) [CBTL04GP043EXJ](#) [MPC8360ZUAJDGA](#) [BSC9131NLE1H H H B](#) [MIMXRT1050-EVK](#) [MPC8260ACVVMHBB](#)
[BYT79-500](#) [MPC8255AVVMHBB](#) [MP3H6115AC6T1](#) [KMI151V3PX](#) [MC7410VU500LE](#) [MCZ33810EK](#) [FXLN8372QR1](#) [LM75BD,112](#)
[TFF1015HN/N1,115](#) [MC33901WEF](#) [CBTL06DP211EE,118](#) [MC33662LEF](#) [MC34901SEF](#) [MFRC52301HN1,151](#) [MC34825EPR2](#)
[CBTW28DD14AETJ](#) [BFU668F,115](#) [PCF8583P](#) [MC34SB0800AE](#) [MC68340AB16E](#) [MC68LK332ACAG16](#) [EVBCRTOUCH](#)
[MC9S08DZ60ACLC](#) [74ALVC125BQ,115](#) [74HC4050N](#) [74HC4514N](#) [MK21FN1M0AVLQ12](#) [MKV30F128VFM10](#) [FRDM-FXS-MULT2-B](#)
[FRDM-KL43Z](#) [FRDM-KW40Z](#) [FRDM-MC-LVBLDC](#) [HEF4028BPN](#) [RAPPID-567XFSW](#) [13237ADC-SFTW](#) [13237ADC-BDM](#)
[MPC860PCVR66D4](#)