

Up to PL e of EN ISO 13849-1 P2HZ X4P



Two-hand control unit for press controllers and safety circuits

Approvals

	P2HZ X4P
	◆
	◆
	◆

Unit features

- ▶ Positive-guided relay outputs:
 - 3 safety contacts (N/O), instantaneous
 - 1 auxiliary contact (N/C), instantaneous
- ▶ Connection options for:
 - 2 operator elements (buttons)
- ▶ LED indicator for:
 - Switch status channel 1/2
 - Supply voltage
- ▶ Plug-in connection terminals (either spring-loaded terminal or screw terminal)
- ▶ See order reference for unit types

Unit description

The two-hand control relay meets the requirements of EN 574 Type IIIC. It forces the operator to keep his hands outside the danger zone area during the hazardous movement. The unit is suitable for use on controllers for metalworking presses as a component for simultaneous switching.

It can be used in applications with

- ▶ Mechanical presses (EN 692)
- ▶ Hydraulic presses (EN 693)

- ▶ Safety circuits in accordance with EN 60204-1

Safety features

The two-hand control relay meets the following safety requirements:

- ▶ The circuit is redundant with built-in self-monitoring
- ▶ The safety function remains effective in the case of a component failure
- ▶ The circuit prevents a further press stroke in the case of:
 - Relay failure
 - Contact welding
 - Coil defect on a relay
 - Open circuit
 - Short circuit

Block diagram

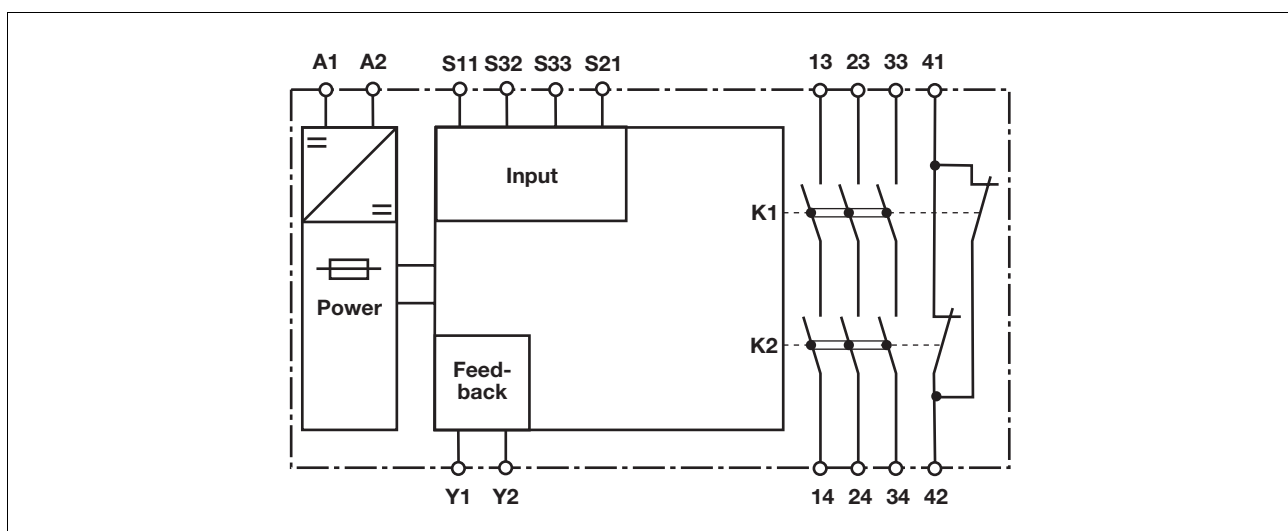

Up to PL e of EN ISO 13849-1 P2HZ X4P

Function description

- ▶ The two-hand control relay must be activated by simultaneously pressing two buttons within **500 ms**. If

one or both of the buttons are released, the unit interrupts the control command for the hazardous movement.

- ▶ Reactivation: The output relays will not re-energise until both operator elements have been released and then re-operated simultaneously.

Timing diagram

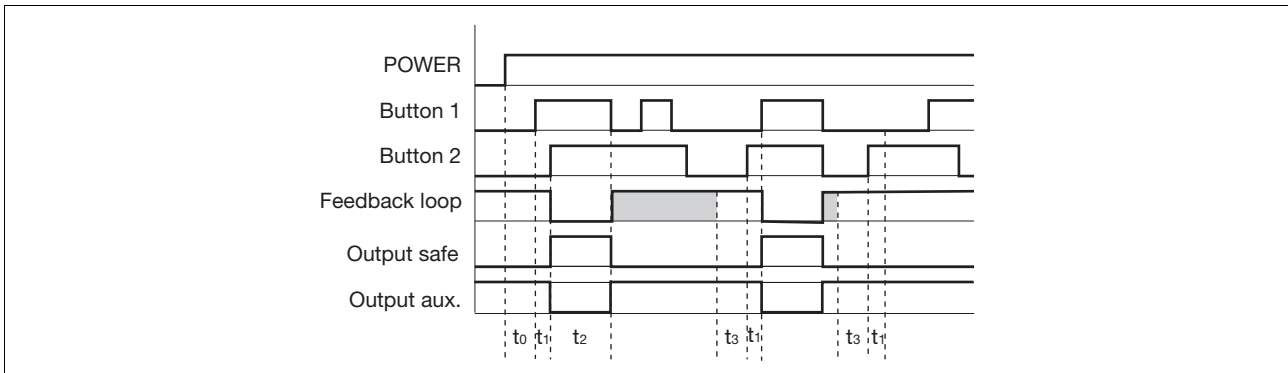

Key

- ▶ **POWER:** Supply voltage
 - ▶ **Button 1/Button 2:** Input circuits S11, S21, S32, S33
 - ▶ **Feedback loop:** Feedback loop Y1-Y2
 - ▶ **Output safe:** Safety outputs 13-14, 23-24, 33-34
 - ▶ **Output aux:** Auxiliary contacts 41-42
 - ▶ t_0 : Recovery time after power on
 - ▶ t_1 : Simultaneity, channel 1 and 2
 - ▶ t_2 : Operating cycle ended through button 1 or 2
 - ▶ t_3 : Y1-Y2 must be closed before before the button is operated (recovery time)
- Shaded area: Status irrelevant

Wiring

Please note:

- ▶ Information given in the "Technical details" must be followed.
- ▶ Outputs 13-14, 23-24, 33-34 are safety contacts, output 41-42 is an auxiliary contact (e.g. for display).
- ▶ To prevent contact welding, a fuse should be connected before the output contacts (see technical details).
- ▶ Calculation of the max. cable runs I_{max} in the input circuit:

$$I_{max} = \frac{R_{lmax}}{R_l / km}$$

R_{lmax} = max. overall cable resistance (see technical details)

R_l / km = cable resistance/km

- ▶ Use copper wire that can withstand 60/75 °C.
- ▶ Sufficient fuse protection must be provided on all output contacts with capacitive and inductive loads.

Up to PL e of EN ISO 13849-1 P2HZ X4P

Preparing for operation

► Supply voltage

Supply voltage	AC	DC

► Input circuit

Input circuit	Single-channel	Dual-channel
Two-hand button with detection of shorts across contacts		

► Feedback loop

Feedback loop	
Contacts from external contactors	

► Key

S1/S2	Two-hand button
-------	-----------------

Up to PL e of EN ISO 13849-1 P2HZ X4P

Terminal configuration

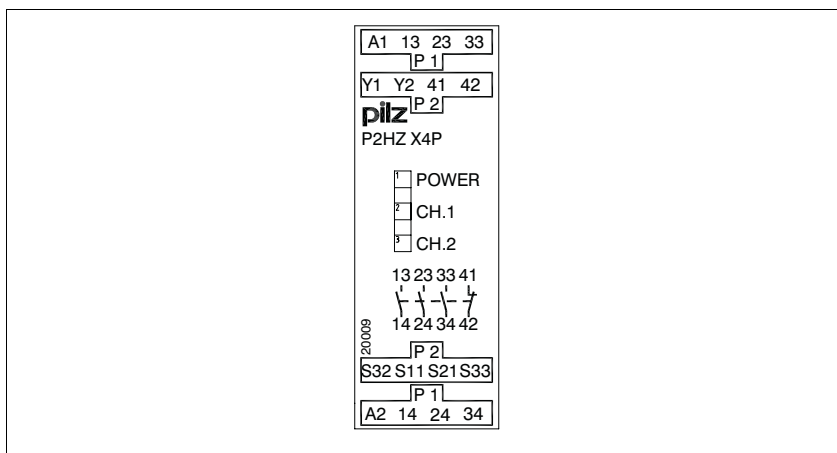

Installation

- ▶ The safety relay should be installed in a control cabinet with a protection type of at least IP54.
- ▶ Use the notch on the rear of the unit to attach it to a DIN rail.
- ▶ Ensure the unit is mounted securely on a vertical DIN rail (35 mm) by using a fixing element (e.g. retaining bracket or an end angle).

Notice

The distance of the button connected to the two-hand relay from the nearest danger zone must be large enough that if one of the buttons is released, the dangerous moment is interrupted before the operator can reach into the danger zone (see EN 999 "The positioning of protective equipment in respect of approach speeds of parts of the human body").

Dimensions

* with spring-loaded terminals

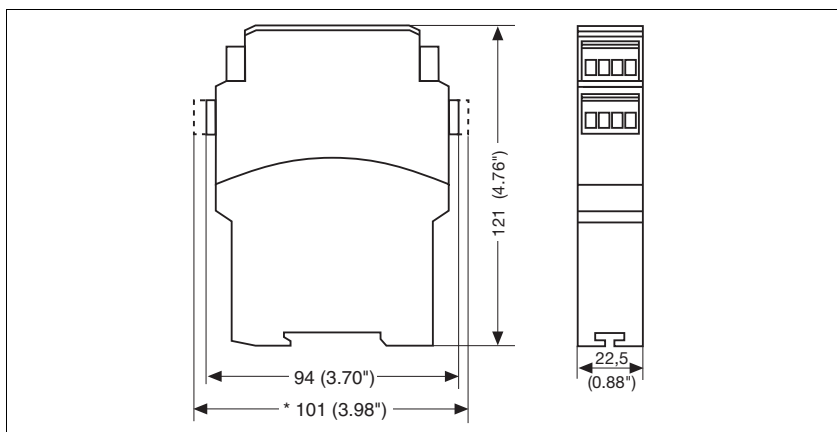

Up to PL e of EN ISO 13849-1 P2HZ X4P

Notice

This data sheet is only intended for use during configuration. For installation and operation, please refer to the operating instructions supplied with the unit.

Service life graph

The service life graphs indicate the number of cycles from which failures due to wear must be expected. The wear is mainly caused by the electrical load; the mechanical load is negligible.

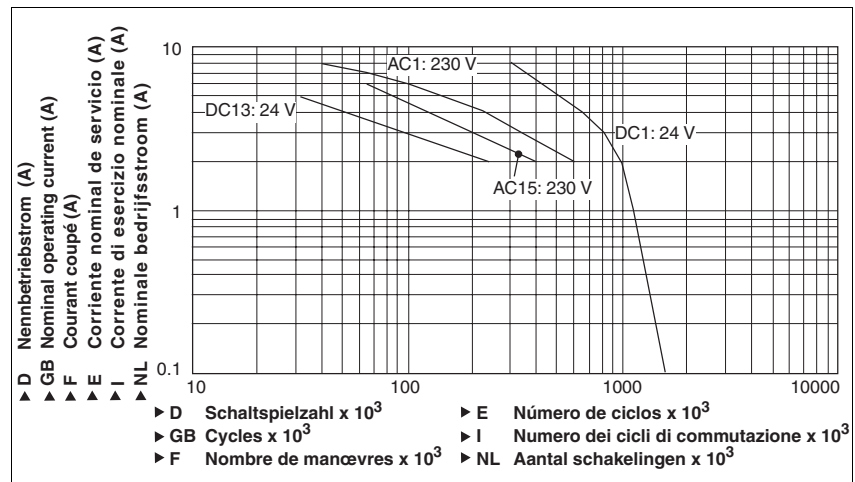

Example

- ▶ Inductive load: 2 A
 - ▶ Utilisation category: AC15
 - ▶ Contact service life: 400 000 cycles
- Provided the application requires fewer than 400 000 cycles, the PFH value

(see technical details) can be used in the calculation.

To increase the service life, sufficient spark suppression must be provided on all output contacts. With capacitive loads, any power surges that occur

must be noted. With contactors, use freewheel diodes for spark suppression.

We recommend you use semiconductor outputs to switch 24 VDC loads.

Technical details	
Electrical data	
Supply voltage	
Supply voltage U _B AC	24 V
Supply voltage U _B DC	24 V
Voltage tolerance	-15 %/+10 %
Power consumption at U _B AC	4.0 VA No. 777354, 787354
Power consumption at U _B DC	2.5 W No. 777355, 787355
Frequency range AC	50 - 60 Hz
Residual ripple DC	10 %
Voltage and current atn	
Input circuit DC: 24.0 V	
N/O contact	15 mA
N/C contact	20 mA No. 777355, 787355 25 mA No. 777354, 787354
Feedback loop DC: 24.0 V	25.0 mA No. 777354, 787354 30.0 mA No. 777355, 787355
Number of output contacts	
Safety contacts (S) instantaneous:	3
Auxiliary contacts (N/C):	1

Up to PL e of EN ISO 13849-1 P2HZ X4P

Electrical data	
Utilisation category in accordance with EN 60947-4-1	
Safety contacts: AC1 at 240 V	I_{\min} : 0.01 A , I_{\max} : 5.0 A P_{\max} : 1250 VA
Safety contacts: DC1 at 24 V	I_{\min} : 0.01 A , I_{\max} : 5.0 A P_{\max} : 125 W
Auxiliary contacts: AC1 at 240 V	I_{\min} : 0.01 A , I_{\max} : 2.5 A P_{\max} : 600 VA
Auxiliary contacts: DC1 at 24 V	I_{\min} : 0.01 A , I_{\max} : 2.5 A P_{\max} : 60 W
Utilisation category in accordance with EN 60947-5-1	
Safety contacts: AC15 at 230 V	I_{\max} : 2.5 A
Safety contacts: DC13 at 24 V (6 cycles/min)	I_{\max} : 1.5 A
Auxiliary contacts: AC15 at 230 V	I_{\max} : 2.5 A
Auxiliary contacts: DC13 at 24 V (6 cycles/min)	I_{\max} : 1.5 A
Conventional thermal current	5.0 A
Contact material	AgSnO₂ + 0.2 µm Au
External contact fuse protection ($I_k = 1$ kA) to EN 60947-5-1	
Blow-out fuse, quick	
Safety contacts:	6 A
Auxiliary contacts:	4 A
Blow-out fuse, slow	
Safety contacts:	4 A
Auxiliary contacts:	2 A
Circuit breaker 24 VAC/DC, characteristic B/C	
Safety contacts:	4 A
Auxiliary contacts:	2 A
Max. overall cable resistance $R_{i\max}$ per input circuit	14 Ohm
Safety-related characteristic data	
PL in accordance with EN ISO 13849-1	PL e (Cat. 4)
Category in accordance with EN 954-1	Cat. 4
SIL CL in accordance with EN IEC 62061	SIL CL 3
PFH in accordance with EN IEC 62061	3.01E-09
SIL in accordance with IEC 61511	SIL 3
PFD in accordance with IEC 61511	3.24E-06
t_M in years	20
Times	
Delay-on de-energisation (reaction time in accordance with EN 574)	
N/O contact	15 ms
N/C contact	30 ms
Recovery time	250 ms
Simultaneity, channel 1 and 2	500 ms
Environmental data	
EMC	EN 60947-5-1, EN 61000-6-2
Vibration to EN 60068-2-6	
Frequency	10 - 55 Hz
Amplitude	0.35 mm
Climatic suitability	EN 60068-2-78
Airgap creepage in accordance with EN 60947-1	
Pollution degree	2
Overvoltage category	III
Rated insulation voltage	250 V
Rated impulse withstand voltage	4.00 kV
Ambient temperature	-25 - 55 °C
Storage temperature	-40 - 85 °C

Up to PL e of EN ISO 13849-1 P2HZ X4P

Environmental data	
Protection type	
Mounting (e.g. cabinet)	IP54
Housing	IP40
Terminals	IP20
Mechanical data	
Housing material	
Housing	PPO UL 94 V0
Front	ABS UL 94 V0
Cross section of external conductors with screw terminals	
1 core flexible	0.25 - 2.50 mm² , 24 - 12 AWG No. 777354, 777355
2 core, same cross section, flexible:	
with crimp connectors, without insulating sleeve	0.25 - 1.00 mm² , 24 - 16 AWG No. 777354, 777355
without crimp connectors or with TWIN crimp connectors	0.20 - 1.50 mm² , 24 - 16 AWG No. 777354, 777355
Torque setting with screw terminals	0.50 Nm No. 777354, 777355
Cross section of external conductors with spring-loaded terminals: Flexible with/without crimp connectors	0.20 - 1.50 mm² , 24 - 16 AWG No. 787354, 787355
Spring-loaded terminals: Terminal points per connection	2 No. 787354, 787355
Stripping length	8 mm No. 787354, 787355
Dimensions	
Height	101.0 mm No. 787354, 787355 94.0 mm No. 777354, 777355
Width	22.5 mm
Depth	121.0 mm
Weight	215 g No. 787354, 787355 220 g No. 777354, 777355

No. stands for order number.

It is essential to consider the relay's service life graphs. The relay outputs' safety-related characteristic data is only valid if the values in the service life graphs are met.

The PFH value depends on the switching frequency and the load on the relay output. If the service life graphs are not accessible, the stated PFH value can be used irrespective of the switching

frequency and the load, as the PFH value already considers the relay's B10d value as well as the failure rates of the other components.

All the units used within a safety function must be considered when calculating the safety characteristic data.

The standards current on **2010-07** apply.

Order reference			
Type	Features	Terminals	Order no.
P2HZ X4P C	24 VAC	Spring-loaded terminals	787 354
P2HZ X4P	24 VAC	Screw terminals	777 354
P2HZ X4P C	24 VDC	Spring-loaded terminals	787 355
P2HZ X4P	24 VDC	Screw terminals	777 355

X-ON Electronics

Largest Supplier of Electrical and Electronic Components

Click to view similar products for [Emergency Stop Switches / E-Stop Switches](#) category:

Click to view products by [Pilz](#) manufacturer:

Other Similar products are found below :

[84-5021.2B40](#) [84-6830.0020](#) [A01ESSP8](#) [A22EL-M-24A-11B](#) [AVN302N-R](#) [A165E-S-01\(STOP\)](#) [AYLD2212602SN-R-TK962](#)
[AVLD39911N-R-24V](#) [A22Z-EG22](#) [A165E-SY](#) [3100.0110Y](#) [3050.1302Y](#) [3SE2243-0XX40](#) [3SK1111-2AB30](#) [3SK1211-1BB40](#) [44-710](#) [84-](#)
[6841.2B20](#) [84-6830.0040](#) [H3141AAKAA](#) [A165E-R-24D-01](#) [E3102AAAAB](#) [A22E-M-03](#) [ZA2BV05](#) [A22EL-M-T2-01](#) [951FY000-WO](#)
[ER6022-022N](#) [952+2000-00](#) [ES3S51653](#) [601+0000-OP](#) [E3101AAAAB](#) [84-5130.0040](#) [CS AR-05V024](#) [CS AR-22V024](#) [DS AE1VA](#) [DS](#)
[KB2A](#) [DS KB3A](#) [HE2G-21SHE-L-K](#) [HE6B-M211Y](#) [774191](#) [774316](#) [777760](#) [R1.100.0129.0 SMA0129- NO/NO](#) [R1.188.0640.0 SNV](#)
[4063KL-A](#) [R1.188.1810.0 SNA 4043K-A](#) [R1.188.1840.0 SNA 4043K-A](#) [SR BD40ALK-B02F](#) [AVLW39911D-R-120V](#) [AYD311NUG](#)
[AVLD32211DNUR](#) [84-5040.0020.0049](#)