

SS8D-GP08H

SmartStep 2 servo drive

Forward in drive simplicity

Simple and Easy set up
Small footprint. The footprint is only 48% that of previous series

Four internal speed settings and
Various other settings
For suppression of vibration and

Commissioning using CX Drive-

Three phase 50 W to 750 W (0.16 to





AC Servo systems

Configuration

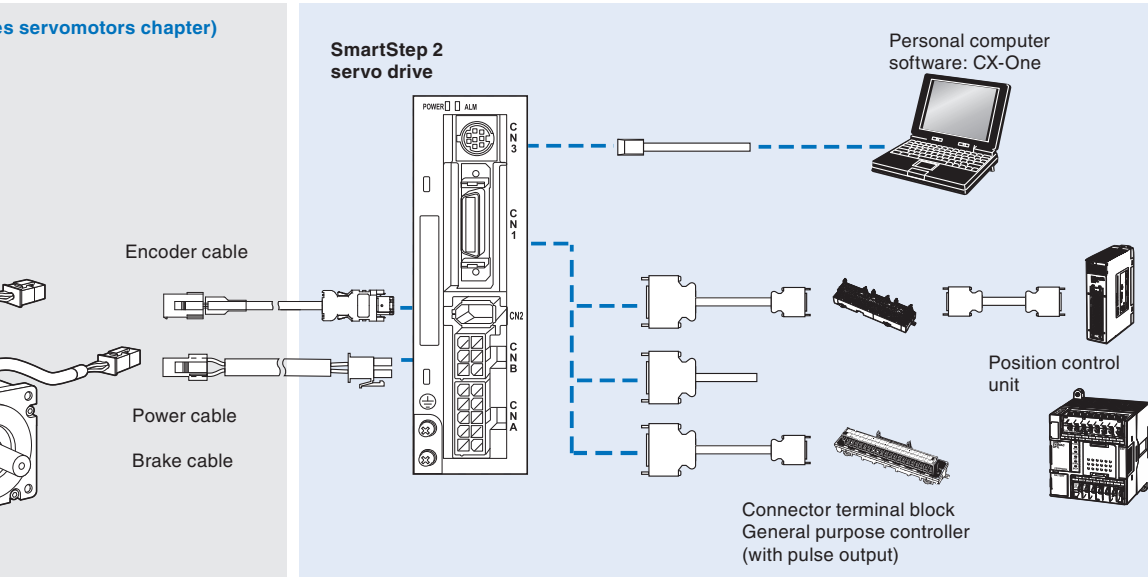
(see servomotors chapter)



Servo drive combination

	Servo motor					SmartStep2 servo drive
	Voltage	Speed	Rated torque	Capacity	Model	
	230 V	3000 min ⁻¹	0.16 Nm	50 W	R88M-G05030H-□S2	R7D-BP01H
			0.32 Nm	100 W	R88M-G10030H-□S2	R7D-BP01H
			0.64 Nm	200 W	R88M-G20030H-□S2	R7D-BP02HH
			1.3 Nm	400 W	R88M-G40030H-□S2	R7D-BP04H
			2.4 Nm	750 W	R88M-G75030H-□S2	R88D-GP08H
	230 V	3000 min ⁻¹	0.32 Nm	100 W	R88M-GP10030H-□S2	R7D-BP01H
			0.64 Nm	200 W	R88M-GP20030H-□S2	R7D-BP02HH
			1.3 Nm	400 W	R88M-GP40030H-□S2	R7D-BP04H

Designation

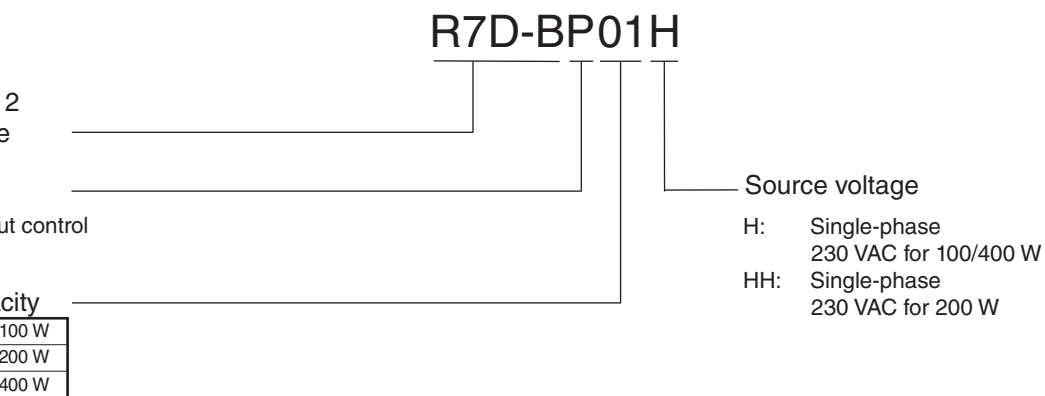

Specifications

Conditions

	Specification
Temperature	0 to 55°C
Humidity	90% max. (with no condensation)
Temperature	-20 to 65°C
Humidity	90% max. (with no condensation)
Atmosphere	No corrosive gases.
	10 to 60 Hz; acceleration : 5.9 m/s ² (0.6G) max.
	Acceleration 19.6 m/s ² max., 3 times each in X, Y, and Z directions,
	Between power supply/power line terminals and frame ground: 0.5 MΩ min. (at 500 VDC)
	Between power supply/power terminals and frame ground: 1,500 VAC for 1 min at 50/60 Hz
	Between each control signal and frame ground: 500 VAC for 1 min
	Built into panel (IP10).
	Approval obtained for UL: UL 508C; cUL: cUL C22.2 No 14
	Approval EC : EMC EN55011 class A Group 1, EN 61000-6-2, low voltage EN50178

AC Servo systems

Specifications

	200 VAC input type			
	100 W	200 W	400 W	750 W
	R7D-BP01H	R7D-BP02HH	R7D-BP04H	R88D-GP08H
Rated current (rms)	1.0 A	1.6 A	2.5 A	4 A
Rated output current (rms)	3.3 A	4.9 A	7.8 A	14.1 A
Supply voltage	Single-phase 200 to 240 VAC (170 to 264 V), 50/60 Hz			Single-phase/three-phase 200 to 240 VAC (170 to 264 V), 50/60 Hz
Power	-			Single-phase 200 to 240 VAC (170 to 264 V)
Control method	All-digital method			
Encoder resolution	10,000 pulses/revolution incremental encoder			
Control method	PWM method based on IGBT			
Carrier frequency	12 kHz		6 kHz	
Weight	0.35 kg	0.42 kg	0.42 kg	1.5 kg
Rated voltage	200 V			
Line speed	Line drive: 500 kpps			
Rated power	50 W 100 W	200 W	400 W	750 W
Model numbers	G05030H G10030H GP10030H	G020030H GP20030H	G40030H GP40030H	G75030H

Names

Drive (100 - 400 W models)

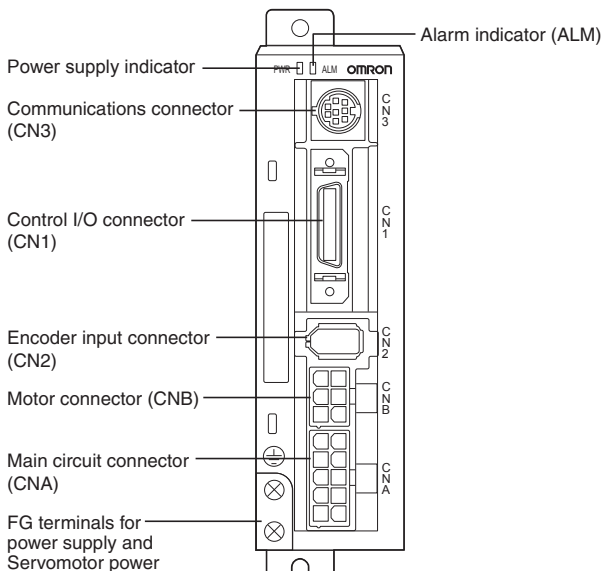

ve (750 W model)

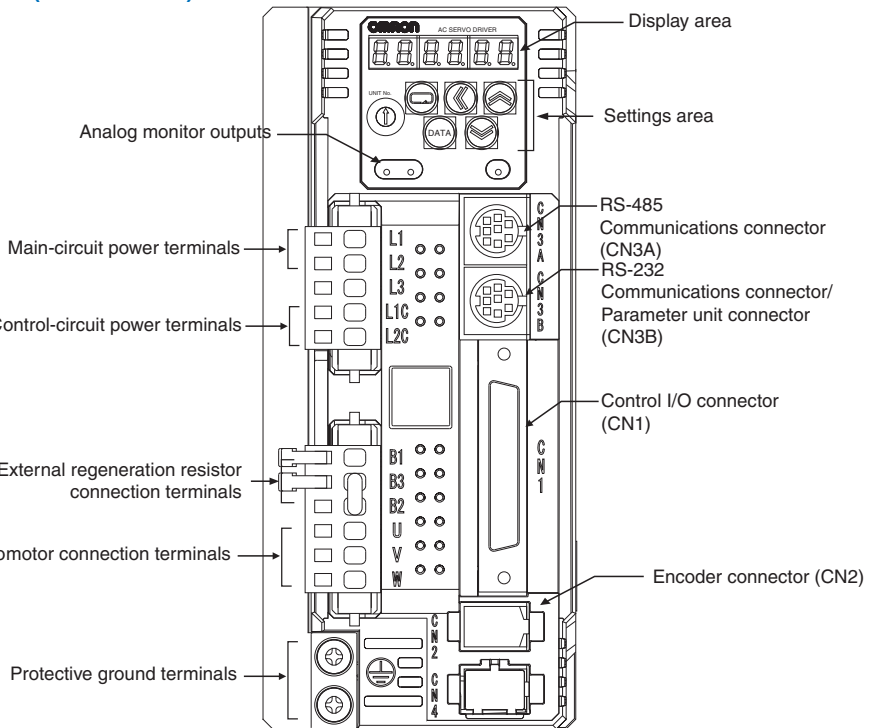

V, 100 W)

R7D-BP02HH/04H (230 V, 200-400 W)

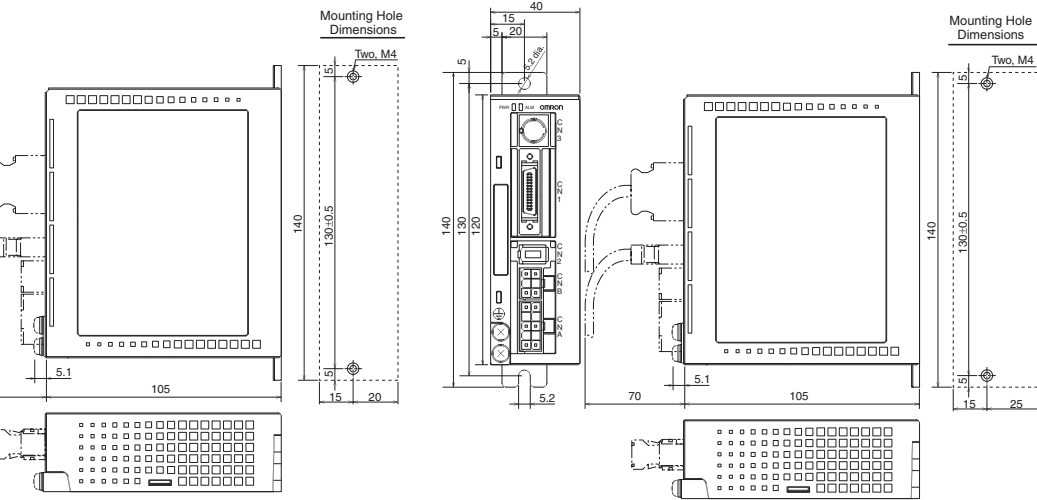

AC Servo systems

V, 750 W)

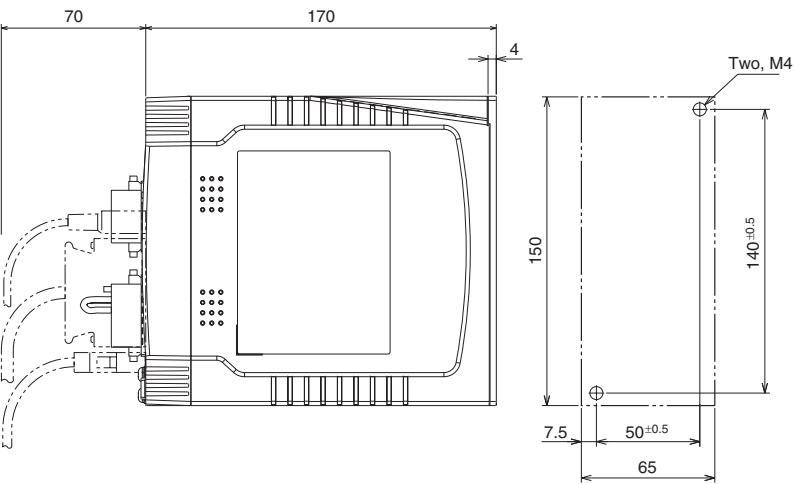

R88A-FIK107-RE

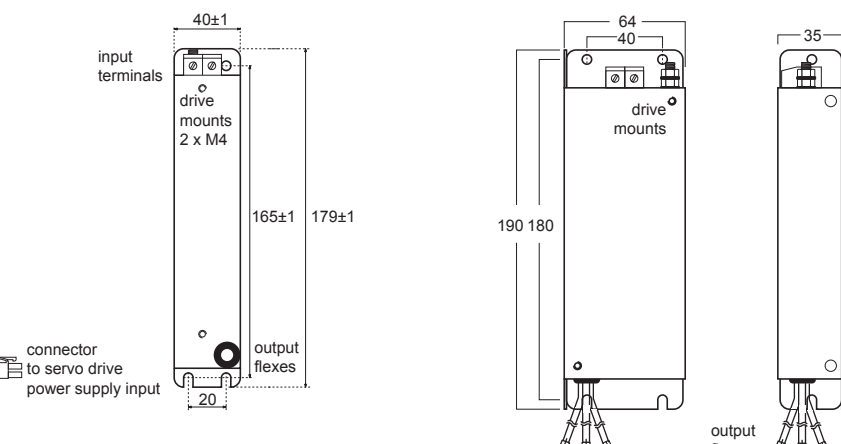

C
→
→
→

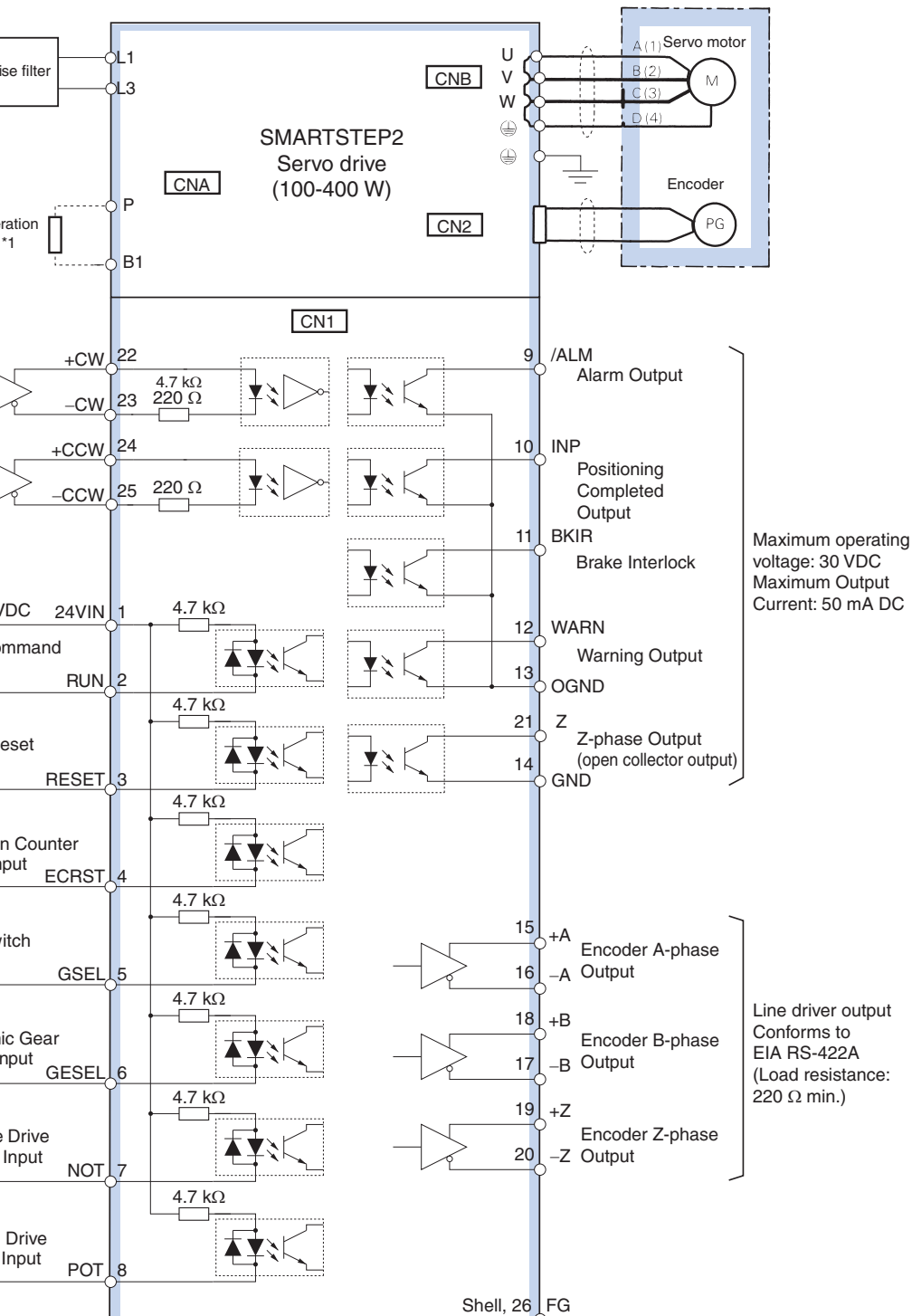

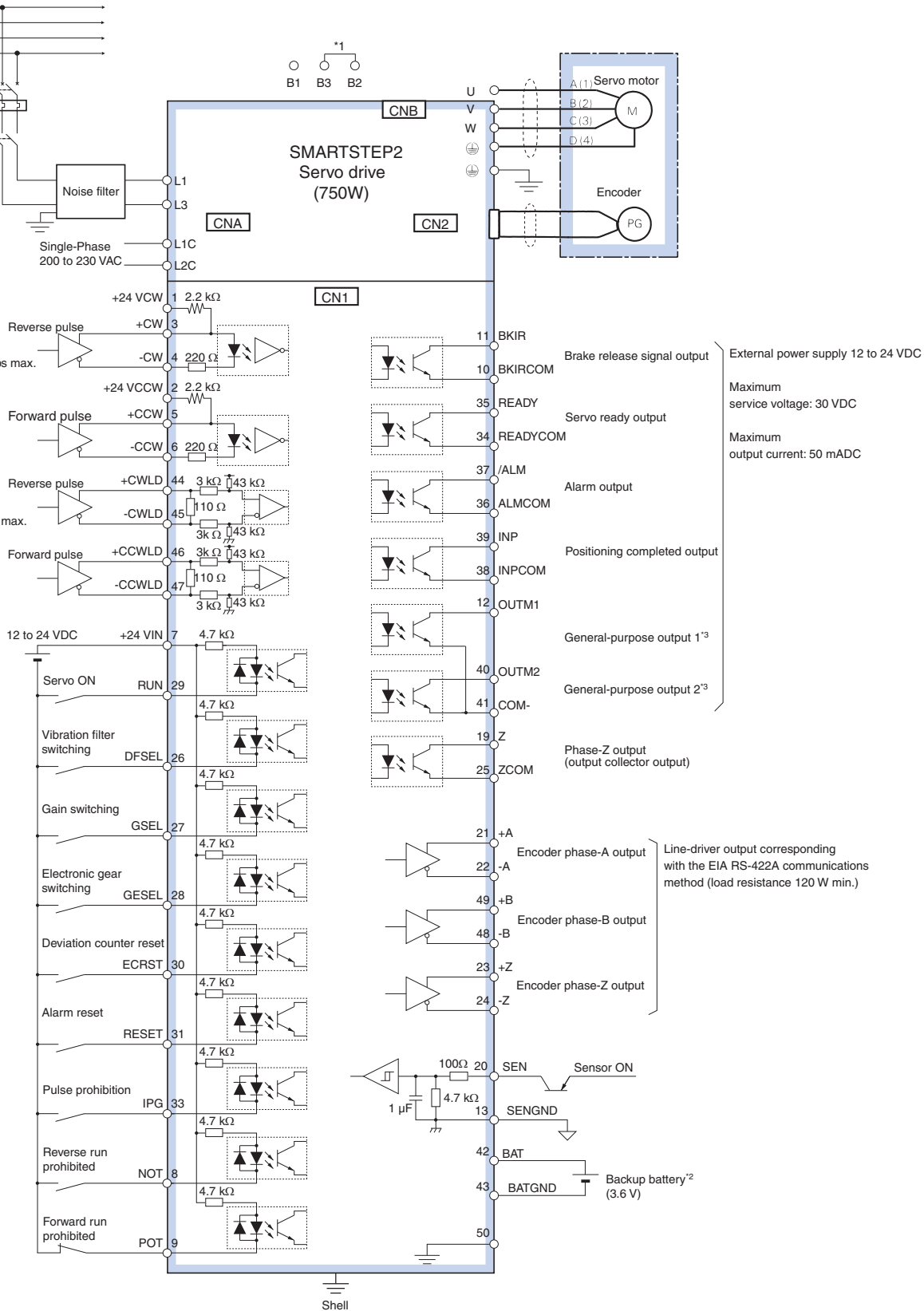

connected. If the internal regenerative resistor is insufficient, remove the wire between B2 and B3 and connect an external regenerative resistor between B1 and B2.

tion

ve Configuration (100-400 W)

(motors chapter)

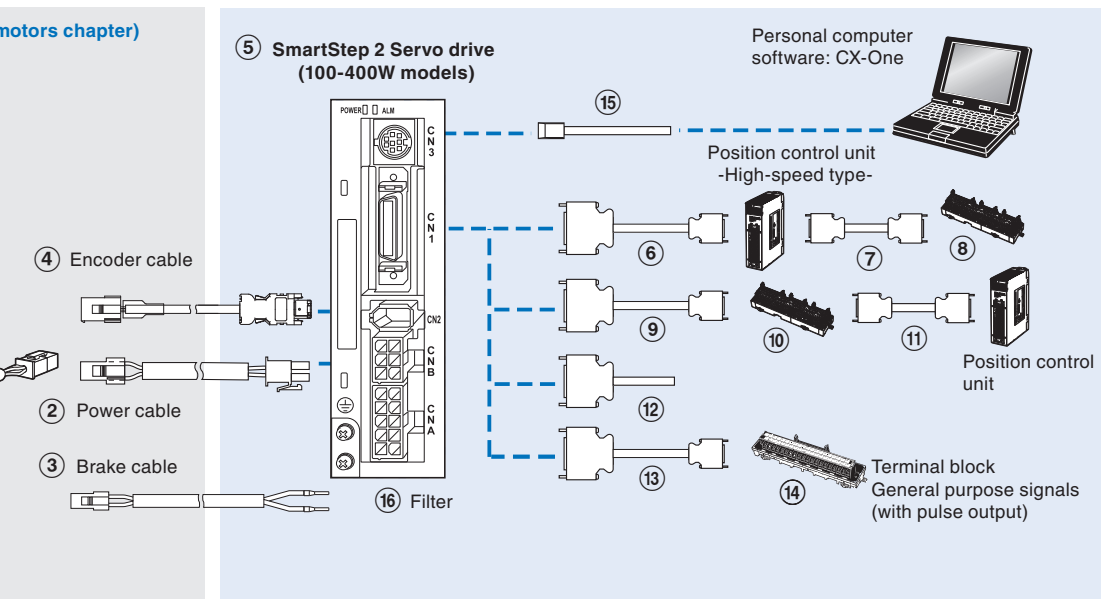

①④⑤... show the recommended sequence to select the components in a SmartStep 2 servo system

g-Series motor chapter for detailed motor specifications and selection.

	SmartStep 2 drive model	Compatible servo motors ①	
		Cylindrical type	Flat type
100 W	R7D-BP01H	R88M-G05030H-□	-
200 W	R7D-BP02HH	R88M-G10030H-□	R88M-GP10030H-□
400 W	R7D-BP04H	R88M-G20030H-□	R88M-GP20030H-□
		R88M-G40030H-□	R88M-GP40030H-□

(for CNA)

	Model	Appearance
Cable for Single-Phase Power (connectors at-	R7A-CLB002S2	

①①)

	Connect to		Model
or 1 axis)	Position control unit (high-speed type) CJ1W-NC234 CJ1W-NC434	1 m	XW2Z-100J-G12
		5 m	XW2Z-500J-G12
		10 m	XW2Z-10MJ-G12
out for 1 axis)	Position control unit (high-speed type) CJ1W-NC214 CJ1W-NC414	1 m	XW2Z-100J-G16
		3 m	XW2Z-300J-G16
or 2 axis)	Position control unit (high-speed type) CJ1W-NC234 CJ1W-NC434	1 m	XW2Z-100J-G4
		5 m	XW2Z-500J-G4
		10 m	XW2Z-10MJ-G4
out for 2 axis)	Position control unit (high-speed type) CJ1W-NC214 CJ1W-NC414	1 m	XW2Z-100J-G8
		3 m	XW2Z-300J-G8
e for external signals forward/reverse run prohibited inputs, ut, origin proximity input and interrupt input)	Position control units (high-speed type) CJ1W-NC234 CJ1W-NC434 CJ1W-NC214 CJ1W-NC414	0.5 m	XW2Z-C50X
		1 m	XW2Z-100X
		2 m	XW2Z-200X
		3 m	XW2Z-300X
		5 m	XW2Z-500X
		10 m	XW2Z-010X

	Connect to	Length	Model
Servo relay unit to servo drive	CS1W-NC1□3, CJ1W-NC1□3, C200HW-NC113, CS1W-NC2□3/4□3, CJ1W-NC2□3/4□3, C200HW-NC213/413, CQM1H-PLB21 or CQM1-CPU43-V1	1 m	XW2Z-100J-B29
		2 m	XW2Z-200J-B29
	CJ1M-CPU21/22/23	1 m	XW2Z-100J-B32
		2 m	XW2Z-200J-B32
Positioning unit	CS1W-NC1□3, CJ1W-NC1□3 or C200HW-NC113 position control unit	-	XW2B-20J6-1B (1 axis)
		-	XW2B-40J6-2B (2 axes)
	CQM1H-PLB21 or CQM1-CPU43-V1	-	XW2B-20J6-3B (1 axis)
		-	XW2B-20J6-8A (1 axis) XW2B-40J6-9A (2 axes)
Control unit connecting cable	CJ1W-NC133	0.5 m	XW2Z-050J-A18
		1 m	XW2Z-100J-A18
	CJ1W-NC233/433	0.5 m	XW2Z-050J-A19
		1 m	XW2Z-100J-A19
	CS1W-NC133	0.5 m	XW2Z-050J-A10
		1 m	XW2Z-100J-A10
	CS1W-NC233/433	0.5 m	XW2Z-050J-A11
		1 m	XW2Z-100J-A11
	CJ1W-NC113	0.5 m	XW2Z-050J-A14
		1 m	XW2Z-100J-A14
	CJ1W-NC213/413	0.5 m	XW2Z-050J-A15
		1 m	XW2Z-100J-A15
	CS1W-NC113 C200HW-NC113	0.5 m	XW2Z-050J-A6
		1 m	XW2Z-100J-A6
	CS1W-NC213/413 C200HW-NC213/413	0.5 m	XW2Z-050J-A7
		1 m	XW2Z-100J-A7
	CJ1M-CPU21/22/23	0.5 m	XW2Z-050J-A33
		1 m	XW2Z-100J-A33
	CQM1H-PLB21 CQM1-CPU43-V1	0.5 m	XW2Z-050J-A3
		1 m	XW2Z-100J-A3
Sense cable	For general purpose controllers	1 m	R7A-CPB001S
		2 m	R7A-CPB002S
Sense cable	For general purpose controllers	1 m	XW2Z-100J-B28
		2 m	XW2Z-200J-B28
		-	XW2B-34G4
		-	XW2B-34G5
1 m	-	XW2D-34G6	

	Length	Model
Computer Monitor Cable	2 m	R88A-CCG002P2

Servo drive	Rated current	Rated voltage	Filter model
Q2HH/ 04H	4 A	1 pH, 230 V	R7A-FIB104-RE

External regeneration resistor cable

	Model
(CNA)	R7A-CNB01P
(CNB)	R7A-CNB01A
(CN1)	R88A-CNW01C
(CN2)	R88A-CNW01R
for Encoder Cable	R88A-CNG02R
for Servomotor Power Cable	R88A-CNG01A R88A-CNG01B

Specifications	Model
External Regenerative Resistor Connection Cable, 2 meters	R7A-CLB002RG

Parameter unit & computer software

Specifications	Model
Parameter copy unit (with cable)	R88A-PR02G
Configuration and monitoring software tool for servo drives and inverters. (CX-drive version 1.8 or higher)	CX-drive

Positioning resistor

	Model
	R88A-RR08050S
	R88A-RR080100S
	R88A-RR22047S

System Configuration (750W)

(see Servo motors chapter)

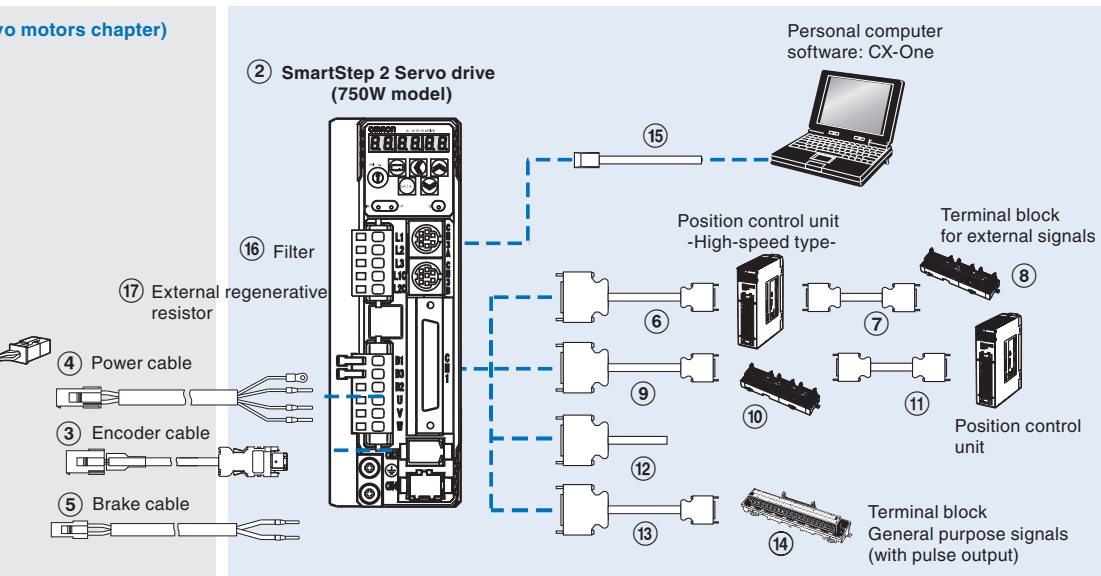

③④⑤... show the recommended sequence to select the components in a SmartStep 2 servo system.

(see S-Series motor chapter for detailed motor specifications and selection.)

AC		Servo drive model	① Compatible rotary servo motors
			Cylindric type
AC	750 W	R88D-GP08H	R88M-G75030H-□

(1)

	Connect to	Model
Output for 1 axis)	Position control units (high-speed type)	1 m XW2Z-100J-G9
	CJ1W-NC234	5 m XW2Z-500J-G9
	CJ1W-NC434	10 m XW2Z-10MJ-G9
or output for 1 axis)	Position control units (high-speed type)	1 m XW2Z-100J-G13
	CJ1W-NC214	3 m XW2Z-300J-G13
Output for 2 axis)	Position control units (high-speed type)	1 m XW2Z-100J-G1
	CJ1W-NC234	5 m XW2Z-500J-G1
	CJ1W-NC434	10 m XW2Z-10MJ-G1
or output for 2 axis)	Position control units (high-speed type)	1 m XW2Z-100J-G5
	CJ1W-NC214	3 m XW2Z-300J-G5
Cable for external signals (Common, forward/reverse run prohibited inputs, stop input, origin proximity input and interrupt)	Position control units (high-speed type)	0.5 m XW2Z-C50X
	CJ1W-NC234	1 m XW2Z-100X
	CJ1W-NC434	2 m XW2Z-200X
	CJ1W-NC214	3 m XW2Z-300X
	CJ1W-NC414	5 m XW2Z-500X
		10 m XW2Z-010X
Cable for external signals (M3 screw, pin terminals)		- XW2B-20G4
Cable for ext. signals (M3.5 screw, fork/round terminals)		- XW2B-20G5
Cable for ext. signals (M3 screw, fork/round terminals)		- XW2D-20G6
Servo relay unit to servo drive	CS1W-NC1□□3, CJ1W-NC1□□3, C200HW-NC113/213/413, CS1W-NC2□□3/4□□3, CJ1W-NC2□□3/4□□3 or CQM1H-PLB21	1 m XW2Z-100J-B25
		2 m XW2Z-200J-B25
	CJ1M-CPU21/22/23	1 m XW2Z-100J-B31
		2 m XW2Z-200J-B31
Unit	CS1W-NC1□□3, CJ1W-NC1□□3 or C200HW-NC113 position control unit	- XW2B-20J6-1B (1 axis)
	CS1W-NC2□□3/4□□3, CJ1W-NC2□□3/4□□3 or C200HW-NC213/413 position control unit	- XW2B-40J6-2B (2 axes)
	CQM1H-PLB21	- XW2B-20J6-3B (1 axis)
	CJ1M-CPU21/22/23	- XW2B-20J6-8A (1 axis)
		-

Application	Connect to	Length	Model
Control unit connecting cable	CQM1H-PLB21	0.5 m	XW2Z-050J-A3
		1 m	XW2Z-100J-A3
	CS1W-NC113 or C200HW-NC113	0.5 m	XW2Z-050J-A6
		1 m	XW2Z-100J-A6
	CS1W-NC213/413 or C200HW-NC213/413	0.5 m	XW2Z-050J-A7
		1 m	XW2Z-100J-A7
	CS1W-NC133	0.5 m	XW2Z-050J-A10
		1 m	XW2Z-100J-A10
	CS1W-NC233/433	0.5 m	XW2Z-050J-A11
		1 m	XW2Z-100J-A11
	CJ1W-NC113	0.5 m	XW2Z-050J-A14
		1 m	XW2Z-100J-A14
	CJ1W-NC213/413	0.5 m	XW2Z-050J-A15
		1 m	XW2Z-100J-A15
	CJ1W-NC133	0.5 m	XW2Z-050J-A18
		1 m	XW2Z-100J-A18
CJ1W-NC233/433	0.5 m	XW2Z-050J-A19	
	1 m	XW2Z-100J-A19	
CJ1M-CPU21/22/23	0.5 m	XW2Z-050J-A33	
	1 m	XW2Z-100J-A33	
General purpose cable	For general purpose controllers	1 m	R88A-CPG001S
		2 m	R88A-CPG002S
Terminal block cable	For general purpose controllers	1 m	XW2Z-100J-B24
		2 m	XW2Z-200J-B24
Terminal block (M3 screw and for pin terminals)		-	XW2B-50G4
Terminal block (M3.5 screw and for fork/round terminals)		-	XW2B-50G5
Terminal block (M3 screw and for fork/round terminals)		-	XW2D-50G6

For CN3)

Application	Length	Model
Power cable RS232	2 m	R88A-CCG002P2

Connectors

Specifications	Model
I/O connector kit -50 pins- (for CN1)	R88A-CNU11C
Power cable connector (motor side)	R88A-CNG01A
Encoder connector (Servo drive side CN2)	R88A-CNW01R
Incremental encoder cable connector (motor side)	R88A-CNG02R

Filter model	Rated current	Leakage current	Rated voltage
R88A-FIK107-RE	6.6 A	3.5 mA	250 VAC single-phase

Computer software

Specifications	Model
Configuration and monitoring software tool for servo drives and inverters (CX-drive version 1.91 or higher).	CX-Drive

Resistive resistor

Resistive resistor unit model	Specifications
R08050S	50 Ω, 80 W
R080100S	100 Ω, 80 W
R22047S	47 Ω, 220 W
R50020S	20 Ω, 500 W

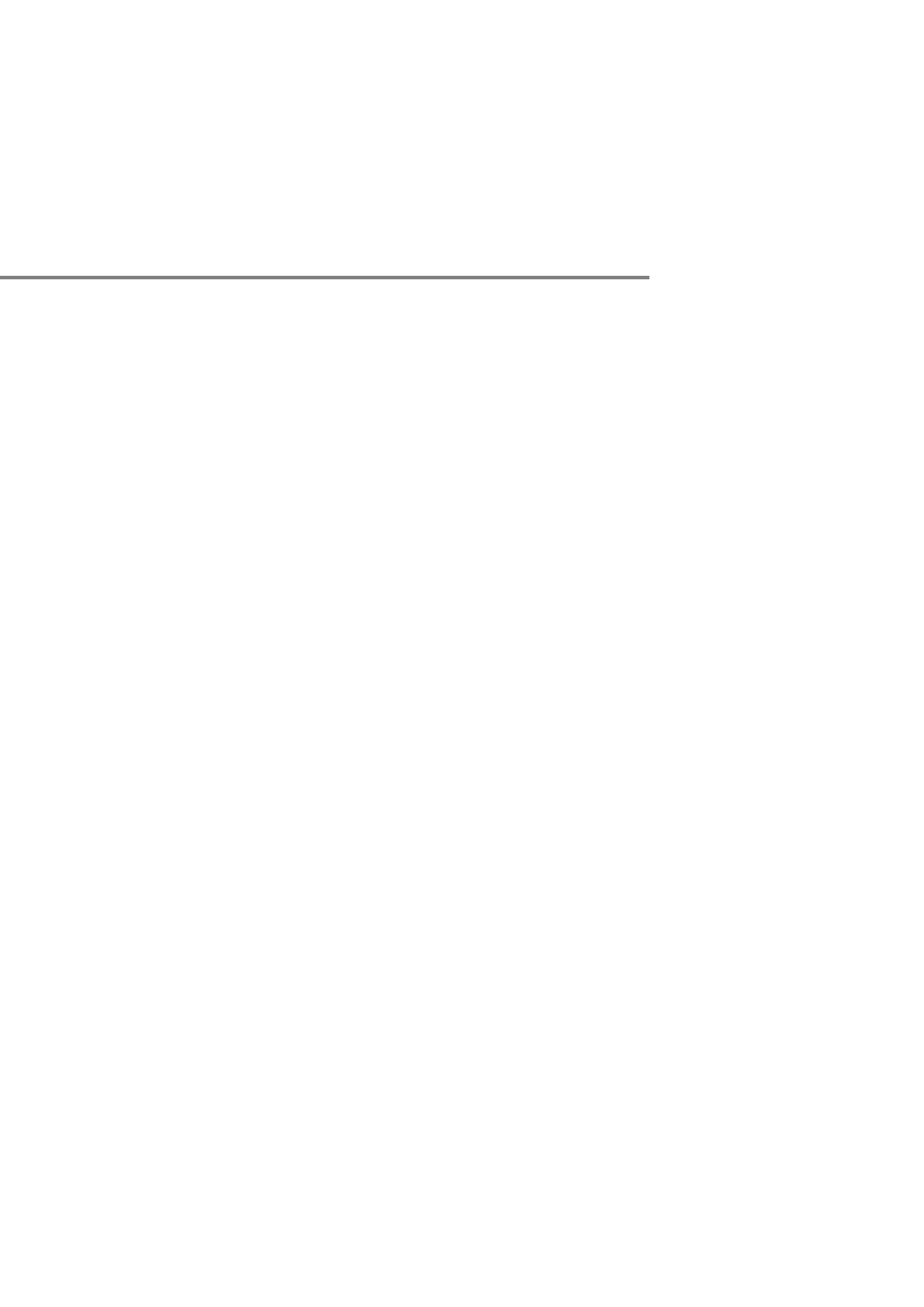

X-ON Electronics

Largest Supplier of Electrical and Electronic Components

Click to view similar products for [Development Tools](#) category:

Click to view products by [Omron](#) manufacturer:

Other Similar products are found below :

[ED430-0040-PA-K-000](#) [ENCCA-03-KH](#) [ENCCA-05-KH](#) [ENCE-03-KH](#) [ENCE-05-KH](#) [FD422-AA-000](#) [FD422S-LA-000](#) [MOT-005-05-KL](#)

[MOTE-005-03-KL](#) [MOTE-005-05-KL](#) [CX-DRIVE 2.9](#)