

FEATURES

- 8th Order Filter in a 14-Pin Package
- 80dB or More Stopband Attenuation at $2 \times f_{\text{CUTOFF}}$
- 50:1, f_{CLK} to f_{CUTOFF} Ratio (Cauer)
100:1, f_{CLK} to $f_{-3\text{dB}}$ Ratio (Transitional)
- 135 μV_{RMS} Total Wideband Noise
- 0.03% THD or Better
- 100kHz Maximum f_{CUTOFF} Frequency
- Operates up to $\pm 8\text{V}$ Power Supplies
- Input Frequency Range up to 50 Times the Filter Cutoff Frequency

APPLICATIONS

- Antialiasing Filters
- Telecom Filters
- Sinewave Generators

 LTC and LT are registered trademarks of Linear Technology Corporation.
LTCMOS is a trademark of Linear Technology Corporation.

DESCRIPTION

The LTC[®]1064-4 is an 8th order, clock sweepable Cauer lowpass switched capacitor filter. An external TTL or CMOS clock programs the value of the filter's cutoff frequency. With Pin 10 at V^+ , the f_{CLK} to f_{CUTOFF} ratio is 50:1; the filter has a Cauer response and with compensation the passband ripple is $\pm 0.1\text{dB}$. The stopband attenuation is 80dB at $2 \times f_{\text{CUTOFF}}$. Cutoff frequencies up to 100kHz can be achieved. With Pin 10 at V^- , the f_{CLK} to $f_{-3\text{dB}}$ ratio is 100:1, the filter has a transitional Butterworth-Cauer response with lower noise and lower delay nonlinearity than the Cauer response. The stopband attenuation at $2.5 \times f_{-3\text{dB}}$ is 92dB. Cutoff frequencies up to 50kHz can be achieved.

The LTC1064-4 features low noise and low harmonic distortion even when input voltages up to $3V_{\text{RMS}}$ are applied. The LTC1064-4 overall performance competes with equivalent multiple op amp active realizations. The LTC1064-4 is pin compatible with the LTC1064-1, LTC1064-2 and LTC1064-3.

The LTC1064-4 is manufactured using Linear Technology's enhanced LTCMOS[™] silicon gate process.

TYPICAL APPLICATION

8th Order Clock Sweepable Lowpass Elliptic Filter

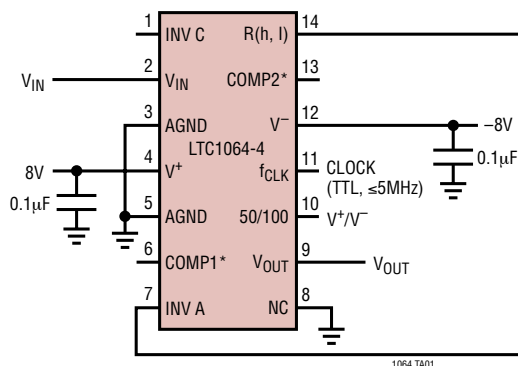

* FOR FREQUENCIES ABOVE 20kHz AND MINIMUM PASSBAND RIPPLE REFER TO THE PIN DESCRIPTION SECTION FOR COMPENSATION GUIDELINES.
NOTE: THE POWER SUPPLIES SHOULD BE BYPASSED BY A 0.1 μF CAPACITOR CLOSE TO THE PACKAGE. BYPASSING PIN 10 WITH 0.1 μF CAPACITOR REDUCES CLOCK FEEDTHROUGH. THE CONNECTION BETWEEN PINS 7 AND 14 SHOULD BE PHYSICALLY DONE UNDER THE PACKAGE.

Frequency Response

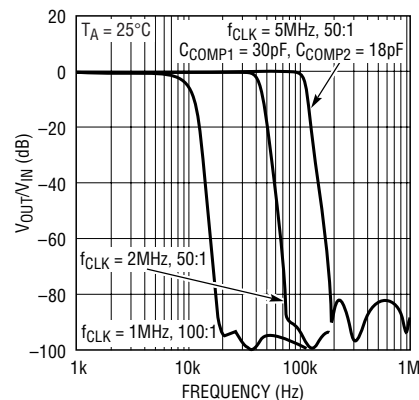

1064-4 TA01b

LTC1064-4

ABSOLUTE MAXIMUM RATINGS (Note 1)

Total Supply Voltage (V^+ to V^-)	16.5V	Lead Temperature (Soldering, 10 sec)	300°C
Input Voltage at Any Pin $V^- - 0.3V \leq V_{IN} \leq V^+ + 0.3V$		Operating Temperature Range	
Power Dissipation	400mW	LTC1064-4M (OBSELETE)	-55°C to 125°C
Storage Temperature Range	-65°C to 150°C	LTC1064-4C	-40°C to 85°C

PACKAGE/ORDER INFORMATION

<p>N PACKAGE 14-LEAD PDIP $T_{JMAX} = 110^\circ\text{C}$, $\theta_{JA} = 70^\circ\text{C/W}$</p>	<p>ORDER PART NUMBER</p> <p>LTC1064-4CN</p>	<p>SW PACKAGE 16-LEAD PLASTIC (WIDE) SO $T_{JMAX} = 150^\circ\text{C}$, $\theta_{JA} = 90^\circ\text{C/W}$</p>	<p>ORDER PART NUMBER</p> <p>LTC1064-4CSW</p>
<p>J PACKAGE 14-LEAD CERDIP</p> <p>OBSELETE PACKAGE Consider the N14 Package for Alternate Source</p>	<p>LTC1064-4MJ LTC1064-4CJ</p>		

Consult LTC Marketing for parts specified with wider operating temperature ranges.

ELECTRICAL CHARACTERISTICS

The ● denotes the specifications which apply over the full operating temperature range, otherwise specifications are at $T_A = 25^\circ\text{C}$. $V_S = \pm 7.5\text{V}$, 50:1, $f_{CLK} = 1\text{MHz}$, $f_C = 20\text{kHz}$, $R_1 = 10\text{k}$, TTL clock input level unless otherwise specified.

PARAMETER	CONDITIONS	MIN	TYP	MAX	UNITS
Passband Gain	Referenced to 0dB, 1Hz to $0.05f_{CUTOFF}$	● -0.5		0.1	dB
Gain TempCo			0.0002		dB/°C
Passband Edge Frequency, f_C			$20 \pm 1\%$		kHz
Gain at f_C	Referenced to Passband Gain, $f_C = 20\text{kHz}$	● -0.4		0.7	dB
-3dB Frequency	50:1 (Cauer Response)		21.5		kHz
	100:1 (Transitional Response)		10		kHz
Passband Ripple (Note 2)	$0.1f_C$ to $0.95f_C$ Referenced to Passband Gain	● -0.15		0.6	dB
Stopband Attenuation	At $1.7f_{CUTOFF}$	● -56	-60		dB
Stopband Attenuation	At $2f_{CUTOFF}$		-80		dB
Input Frequency Range	50:1, Pin 10 at V^+	0		f_{CLK}	kHz
	100:1, Pin 10 at V^-	0		$f_{CLK}/2$	kHz
Output Voltage Swing and Operating Input Voltage Range	$V_S = \pm 2.37\text{V}$	● ± 1.1			V
	$V_S = \pm 5\text{V}$	● ± 3.1			V
	$V_S = \pm 7.5\text{V}$	● ± 5.0			V
Total Harmonic Distortion	$V_S = \pm 5\text{V}$, Input = $1V_{RMS}$ at 1kHz		0.015		%
	$V_S = \pm 7.5\text{V}$, Input = $3V_{RMS}$ at 1kHz		0.03		%
Wideband Noise	$V_S = \pm 5\text{V}$, Input = GND 1Hz to 999kHz		120		μV_{RMS}
	$V_S = \pm 7.5\text{V}$, Input = GND 1Hz to 999kHz		135		μV_{RMS}

10644fb

ELECTRICAL CHARACTERISTICS The ● denotes the specifications which apply over the full operating temperature range, otherwise specifications are at $T_A = 25^\circ\text{C}$. $V_S = \pm 7.5\text{V}$, 50:1, $f_{\text{CLK}} = 1\text{MHz}$, $f_c = 20\text{kHz}$, $R_1 = 10\text{k}$, TTL clock input level unless otherwise specified.

PARAMETER	CONDITIONS	MIN	TYP	MAX	UNITS
Output DC Offset	$V_S = \pm 7.5\text{V}$		±50	±160	mV
Output DC Offset TempCo	$V_S = \pm 5\text{V}$ $V_S = \pm 7.5\text{V}$		-100 -200		$\mu\text{V}/^\circ\text{C}$ $\mu\text{V}/^\circ\text{C}$
Input Impedance		9	13		$\text{k}\Omega$
Output Impedance	$f_{\text{OUT}} = 10\text{kHz}$		2		Ω
Output Short-Circuit Current	Source/Sink		3/1		mA
Clock Feedthrough	Input = GND		200		μV_{RMS}
Maximum Clock Frequency	$V_S = \pm 7.5\text{V}$, 50% Duty Cycle (Note 3)			5	MHz
Power Supply Current	$V_S = \pm 2.37\text{V}$, $f_{\text{CLK}} = 1\text{MHz}$	●	11	22	mA
	$V_S = \pm 5\text{V}$, $f_{\text{CLK}} = 1\text{MHz}$	●	14	23	mA
	$V_S = \pm 7.5\text{V}$, $f_{\text{CLK}} = 1\text{MHz}$	●	17	28	mA
		●		32	mA
Power Supply Voltage Range		●	±2.37	±8	V

Note 1: Absolute Maximum Ratings are those values beyond which the life of a device may be impaired.

Note 2: For tighter passband ripple specifications please consult with LTC's marketing.

Note 3: Not tested, guaranteed by design.

TYPICAL PERFORMANCE CHARACTERISTICS

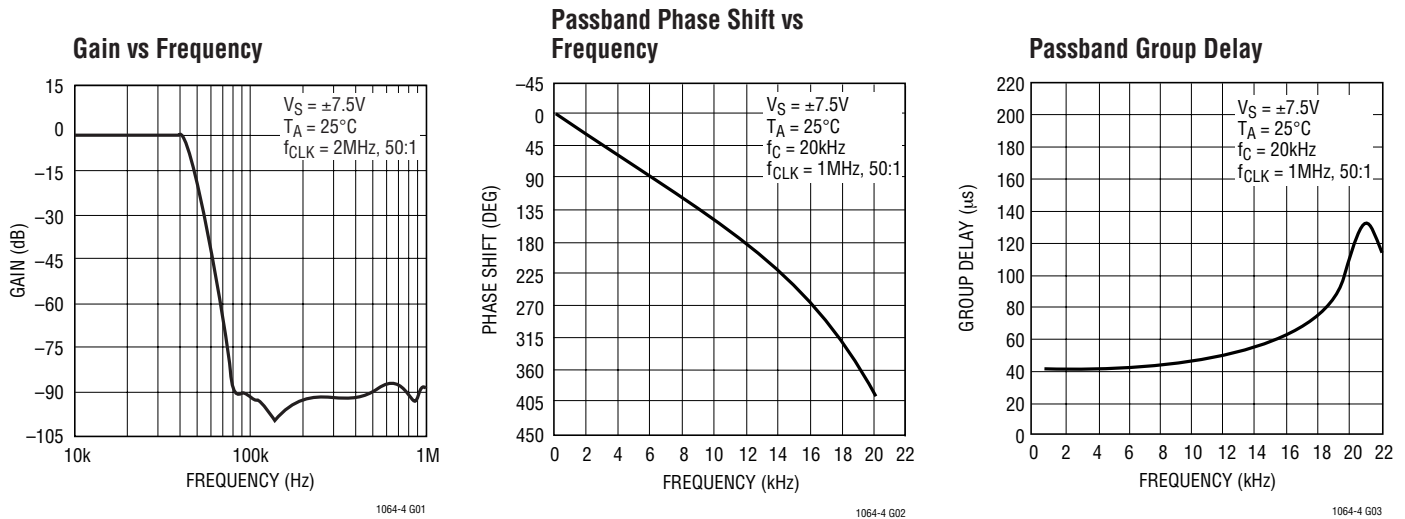

TYPICAL PERFORMANCE CHARACTERISTICS

Gain vs Frequency with Compensation

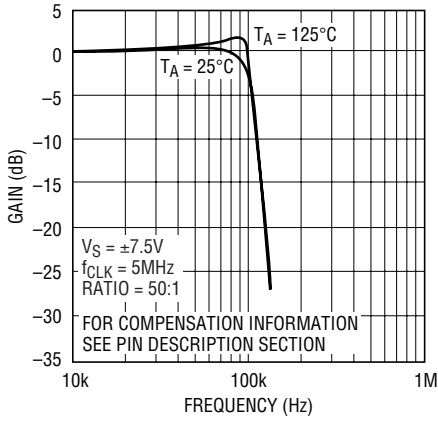

1064-4 G04

Device to Device Phase Matching

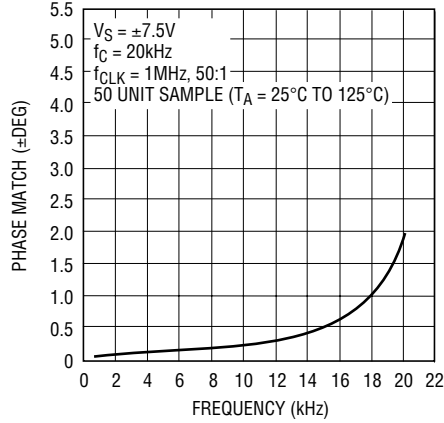

1064-4 G05

Total Harmonic Distortion

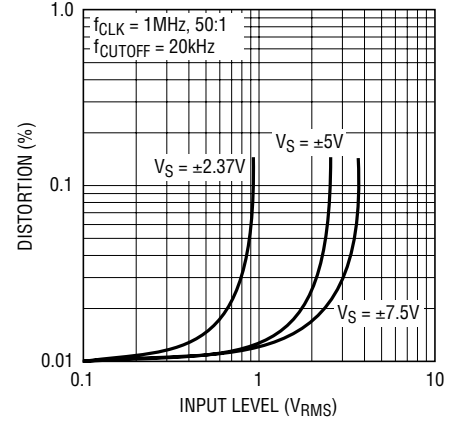

1064-4 G06

Power Supply Current vs Power Supply Voltage

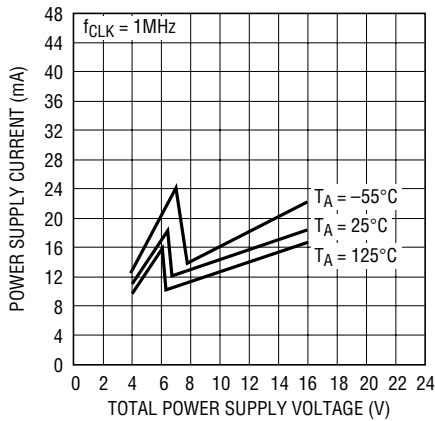

1064-4 G07

Transient Response
 $f_{CLK} = 1\text{MHz}$, Ratio = 50:1,
 $f_C = 20\text{kHz}$, $V_S = \pm 7.5\text{V}$, 1kHz
 Square Wave Input

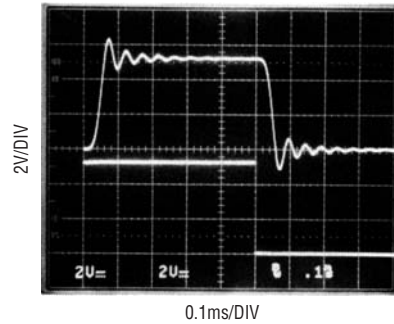

Table 1. Wideband Noise (μVRMS). Input Grounded, $f_{CLK} = 1\text{MHz}$

		$V_S = \pm 2.37\text{V}$	$V_S = \pm 5\text{V}$	$V_S = \pm 7.5\text{V}$
Pin 10 to	f_{CLK}/f_{CUTOFF}	Noise μVRMS	Noise μVRMS	Noise μVRMS
V^+	50:1	120	135	145
V^-	100:1	100	120	130

TYPICAL PERFORMANCE CHARACTERISTICS

Table 2. Gain/Phase, Pin 10 at V⁺, Typical Response
 $f_{\text{CUTOFF}} = 1\text{kHz}$, $V_S = \pm 5\text{V}$, $T_A = 25^\circ\text{C}$, $f_{\text{CLK}} = 50\text{kHz}$, Ratio = 50:1

FREQUENCY(kHz)	GAIN (dB)	PHASE (deg)
0.200	-0.075	-59.990
0.400	-0.050	-122.400
0.600	0.020	169.300
0.800	0.060	88.500
1.000	0.090	-26.100
1.200	-15.640	-175.100
1.400	-34.700	126.500
1.600	-51.700	87.600
1.800	-68.600	38.400
2.000	-84.110	-47.860

Table 3. Gain/Delay, Pin 10 at V⁺, Typical Response
 $f_{\text{CUTOFF}} = 1\text{kHz}$, $V_S = \pm 5\text{V}$, $T_A = 25^\circ\text{C}$, $f_{\text{CLK}} = 50\text{kHz}$, Ratio = 50:1

FREQUENCY(kHz)	GAIN (dB)	DELAY (ms)
0.200	-0.074	0.844
0.300	-0.070	0.867
0.400	-0.050	0.899
0.500	-0.020	0.949
0.600	0.020	1.021
0.700	0.050	1.122
0.800	0.060	1.275
0.900	0.120	1.592
1.000	0.090	2.160
1.100	-5.020	2.070
1.200	-15.650	1.288

Table 4. Gain/Phase, Pin 10 at V⁻, Typical Response
 $f_{-3\text{dB}} = 1\text{kHz}$, $V_S = \pm 5\text{V}$, $T_A = 25^\circ\text{C}$, $f_{\text{CLK}} = 100\text{kHz}$, Ratio = 100:1

FREQUENCY(kHz)	GAIN (dB)	PHASE (deg)
0.200	-0.179	-60.090
0.400	-0.440	-122.000
0.600	-0.810	170.800
0.800	-1.480	91.900
1.000	-3.500	-16.300
1.200	-17.720	-140.500
1.400	-35.700	164.800
1.600	-52.700	135.000
1.800	-71.900	114.000
2.000	-96.160	-49.670

Table 5. Gain/Delay, Pin 10 at V⁻, Typical Response
 $f_{-3\text{dB}} = 1\text{kHz}$, $V_S = \pm 5\text{V}$, $T_A = 25^\circ\text{C}$, $f_{\text{CLK}} = 100\text{kHz}$, Ratio = 100:1

FREQUENCY(kHz)	GAIN (dB)	DELAY (ms)
0.200	-0.174	0.842
0.300	-0.300	0.861
0.400	-0.440	0.888
0.500	-0.610	0.933
0.600	-0.810	0.999
0.700	-1.090	1.095
0.800	-1.480	1.242
0.900	-2.080	1.503
1.000	-3.500	1.832
1.100	-8.720	1.724
1.200	-17.720	1.183

Table 6. Gain/Phase, Pin 10 at GND
 $V_S = \pm 5\text{V}$, $T_A = 25^\circ\text{C}$

FREQUENCY(kHz)	GAIN (dB)	PHASE (deg)
0.200	-0.383	-47.140
0.400	-1.000	-92.000
0.600	-1.300	-134.300
0.800	-0.280	-178.800
1.000	2.670	109.200
1.200	-3.500	6.000
1.400k	-12.510	-47.400
1.600	-20.000	-88.800
1.800	-27.300	-127.800
2.000	-35.000	-164.200

TYPICAL PERFORMANCE CHARACTERISTICS

Table 7. Gain/Phase for Figure 6.
 Typical Response, Pin 10 at V⁺, f_{CUTOFF} = 40kHz,
 V_S = ±7.5V, f_{CLK} = 2MHz, Ratio = 50:1

FREQUENCY (kHz)	GAIN (dB)	PHASE (deg)
10.000	-0.094	-75.900
12.000	-0.100	-91.400
14.000	-0.090	-107.200
16.000	-0.080	-123.300
18.000	-0.060	-139.600
20.000	-0.040	-156.500
22.000	-0.020	-173.800
24.000	0.000	168.200
26.000	0.020	149.400
28.000	0.030	130.000
30.000	0.020	109.400
32.000	0.010	87.700
34.000	-0.020	64.600
36.000	-0.030	39.500
38.000	-0.010	11.400
40.000	-0.070	-22.000
42.000	-0.920	-64.100
44.000	-4.000	-110.100
46.000	-8.970	-147.000
48.000	-14.320	-173.500
50.000	-19.460	166.800

Table 8. Gain/Phase for Figure 7.
 Typical Response, Pin 10 at V⁺, f_{CUTOFF} = 100kHz,
 V_S = ±7.5V, T_A = 25°C, f_{CLK} = 5MHz, Ratio = 50:1

FREQUENCY (kHz)	GAIN (dB)	PHASE (deg)
10.000	-0.096	-32.390
20.000	-0.100	-64.900
30.000	-0.080	-98.100
40.000	-0.040	-132.300
50.000	0.020	-168.200
60.000	0.070	153.600
70.000	0.040	112.100
80.000	-0.120	66.400
90.000	-0.460	14.600
100.000	-1.310	-49.300
110.000	-5.640	-129.000
120.000	-14.530	167.800
130.000	-23.800	126.700
140.000	-32.600	96.200
150.000	-41.000	71.300
160.000	-49.200	49.200
170.000	-57.500	29.000
180.000	-66.500	9.800
190.000	-77.770	-2.320
200.000	-92.050	76.740

Table 9. Gain/Phase for Figure 7.
 Typical Response, Pin 10 at V⁺, f_{CUTOFF} = 100kHz,
 V_S = ±7.5V, T_A = 125°C, f_{CLK} = 5MHz, Ratio = 50:1

FREQUENCY (kHz)	GAIN (dB)	PHASE (deg)
10.000	-0.071	-33.800
20.000	-0.040	-67.800
30.000	0.050	-102.500
40.000	0.190	-138.300
50.000	0.410	-176.100
60.000	0.670	143.100
70.000	0.920	98.400
80.000	1.150	48.200
90.000	1.530	-10.900
100.000	1.110	-96.500

FREQUENCY (kHz)	GAIN (dB)	PHASE (deg)
110.000	-7.420	172.100
120.000	-18.240	119.400
130.000	-28.000	83.300
140.000	-37.000	54.000
150.000	-45.700	-27.600
160.000	-54.300	2.100
170.000	-63.300	-24.900
180.000	-73.610	-60.210
190.000	-85.300	-138.990
200.000	-83.390	129.580

PIN FUNCTIONS (Pin Numbers Refer to the 14-Pin Package)

INV C, COMP1, INV A, COMP2 (Pins 1, 6, 7 and 13): To obtain a Cauer response with minimum passband ripple and cutoff frequencies above 20kHz, compensating components are required. Figure 6 uses $\pm 7.5V$ power supplies and compensation components to achieve up to 40kHz *sweepable* cutoff frequencies and $\pm 0.1dB$ passband ripple. Table 7 lists the typical amplitude response of Figure 6. Figure 7 illustrates the compensation scheme required to obtain a 100kHz cutoff frequency; Graph 4 and Tables 8 and 9 list the typical response of Figure 7 for 25°C and 125°C ambient temperature. As shown the ripple increases at high temperatures but still a $\pm 0.25dB$ figure can be obtained for ambient temperatures below 70°C.

V_{IN}, V_{OUT} (Pins 2, 9): The input Pin 2 is connected to a 12k resistor tied to the inverting input of an op amp. Pin 2 is protected against static discharge. The device's output, Pin 9, is the output of an op amp which can typically source/sink 3mA/1mA. Although the internal op amps are unity gain stable, driving long coax cables is not recommended.

When testing the device for noise and distortion, the output, Pin 9, should be buffered (Figure 4). *The op amp power supply wire (or trace) should be connected directly to the power source.* To eliminate any output clock feedthrough, Pin 9 should be buffered with a simple R, C lowpass filter (Figure 5). The cutoff frequency of the output filter should be $f_{CLK}/3$.

AGND (Pins 3, 5): For dual supply operation these pins should be connected to a ground plane. For single supply operation both pins should be tied to one half supply (Figure 2).

V⁺, V⁻ (Pins 4, 12): Should be bypassed with a 0.1 μF capacitor to an adequate analog ground. Low noise, nonswitching power supplies are recommended. *To avoid latchup when the power supplies exhibit high turn-on transients, a 1N5817 Schottky diode should be added from the V⁺ and V⁻ pins to ground (Figures 1 and 2).*

INV A, R(h, l) (Pins 7, 14): A very short connection between Pin 7 and Pin 14 is recommended. This connection should be preferably done under the IC package. In a breadboard, use a one inch, or less, shielded coaxial cable; the shield should be grounded. In a PC board, use a one inch trace or less; surround the trace by a ground plane.

NC (Pin 8): Pin 8 is not internally connected, it should be preferably grounded.

50/100 Ratio (Pin 10): For an f_{CLK}/f_C ratio of 50:1, Pin 10 should be tied to V⁺. For an f_{CLK}/f_{-3dB} ratio of 100:1, Pin 10 should be tied to V⁻. When Pin 10 is at midsupplies (i.e. ground), the filter response is neither Cauer nor transitional. Table 6 illustrates this response. Bypassing Pin 10 with a 0.1 μF capacitor reduces the already small clock feedthrough.

TYPICAL APPLICATIONS

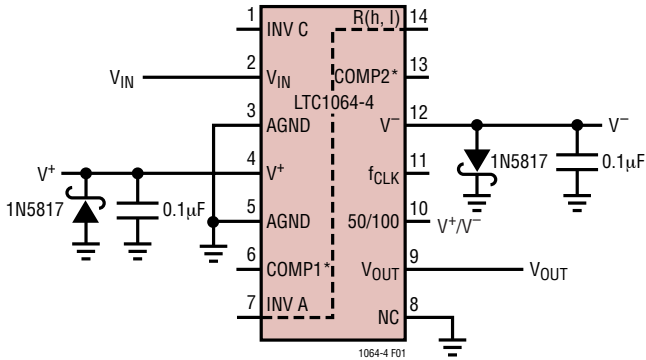

Figure 1. Using Schottky Diodes to Protect the IC from Power Supply Spikes

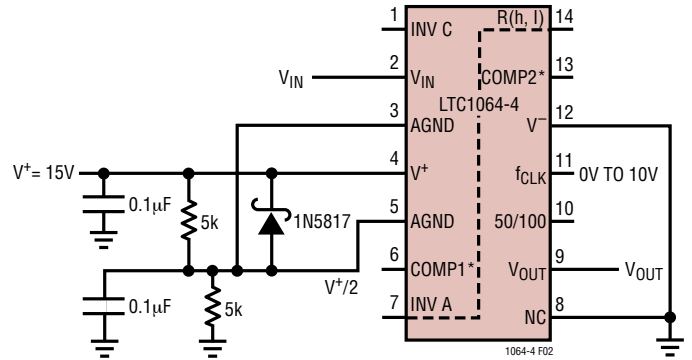

Figure 2. Single Supply Operation. If Fast Power Up or Down Transients are Expected, Use a 1N5817 Schottky Diode Between Pin 4 and Pin 5.

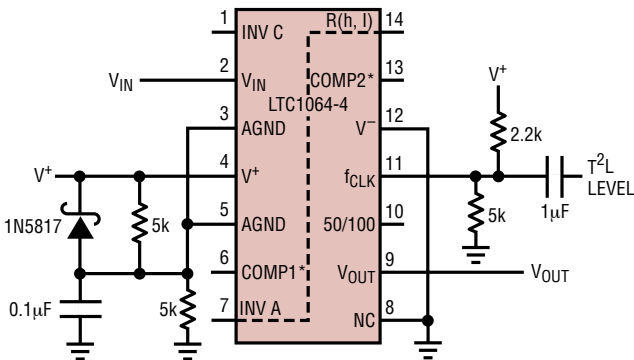

Figure 3. Level Shifting the Input T²L Clock for Single Supply Operation ≥6V.

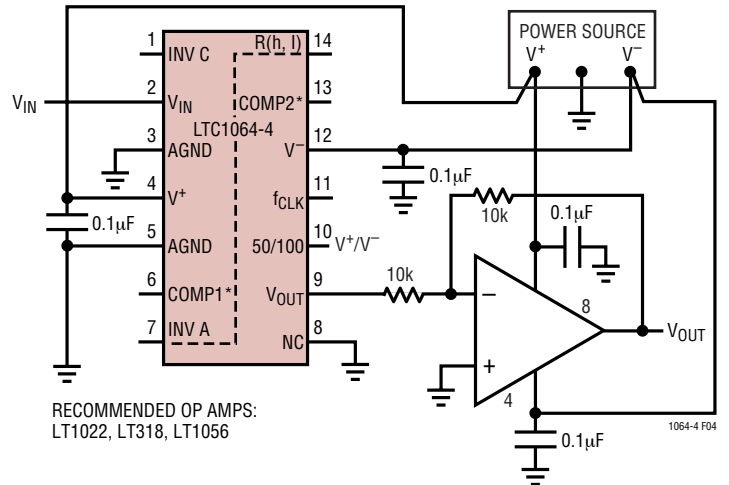

Figure 4. Buffering the Filter Output. The Buffer Op Amp Should Not Share the LTC1064-4 Power Lines.

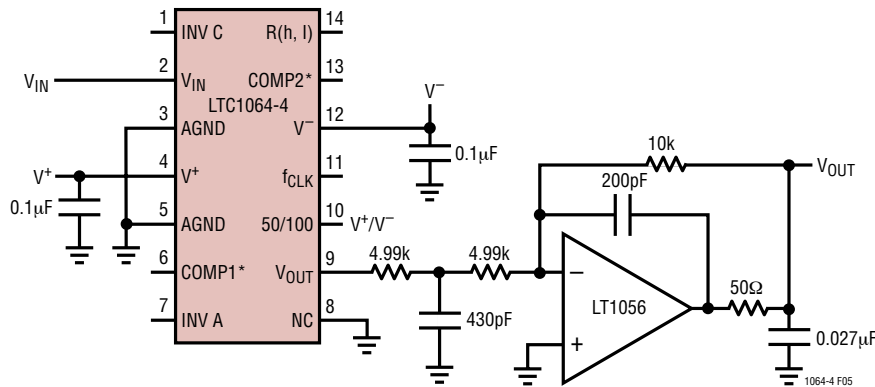
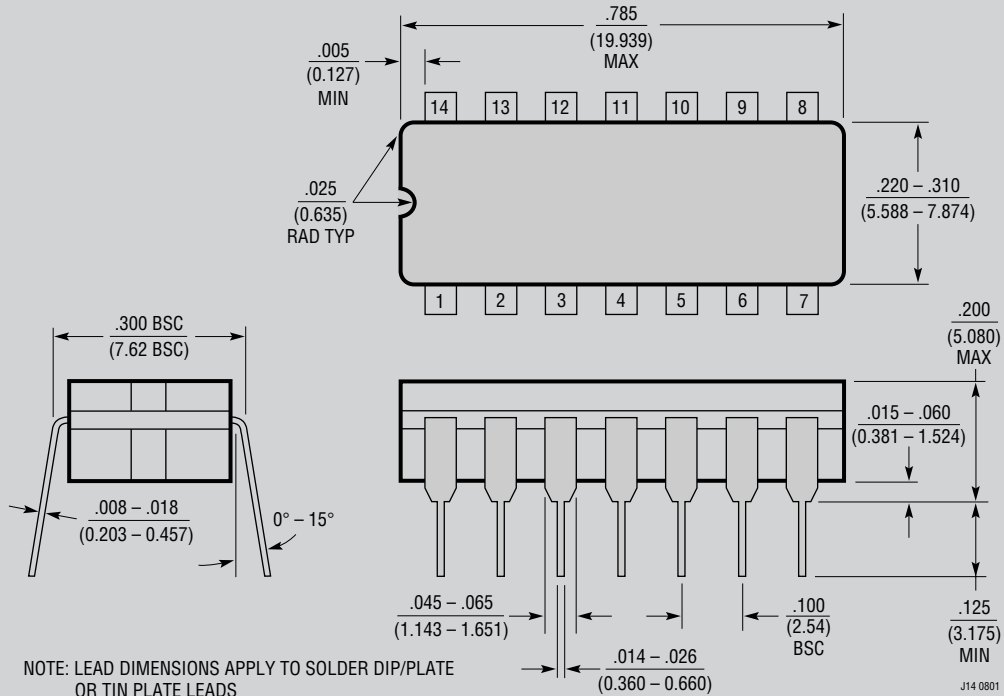

Figure 5. Adding an Output Buffer-Filter to Eliminate Any Clock Feedthrough. Passband Error of Output Buffer is ±0.1dB to 50kHz, -3dB at 94kHz.

PACKAGE DESCRIPTION

J Package
14-Lead CERDIP (Narrow 0.300, Hermetic)
 (LTC DWG # 05-08-1110)



OBsolete PACKAGE

J14 0801

PACKAGE DESCRIPTION

N Package
14-Lead PDIP (Narrow 0.300)
 (LTC DWG # 05-08-1510)

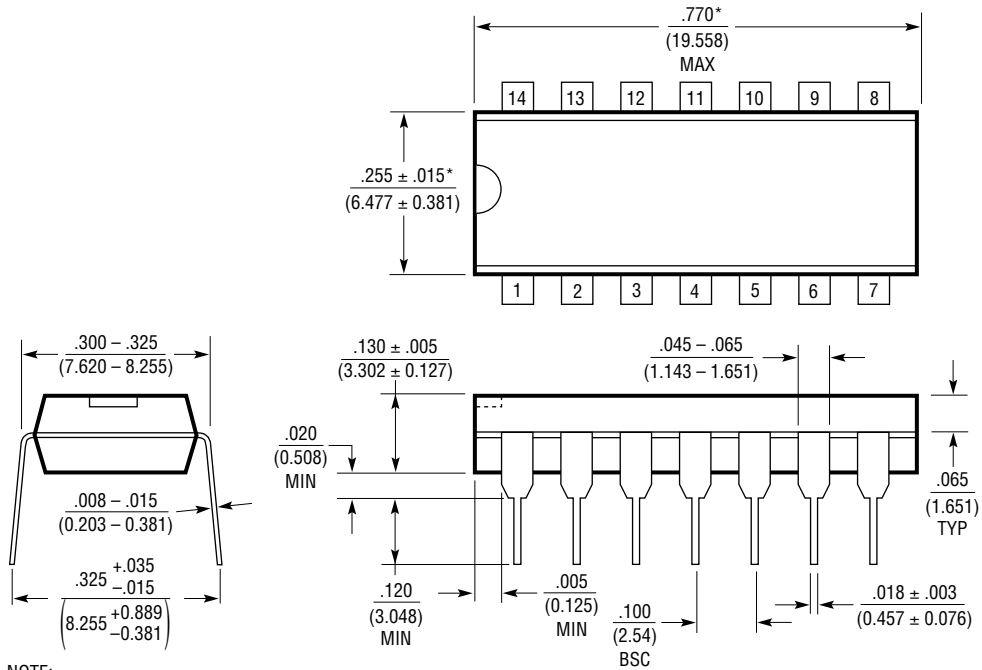

NOTE:
 1. DIMENSIONS ARE $\frac{\text{INCHES}}{\text{MILLIMETERS}}$

*THESE DIMENSIONS DO NOT INCLUDE MOLD FLASH OR PROTRUSIONS.
 MOLD FLASH OR PROTRUSIONS SHALL NOT EXCEED .010 INCH (0.254mm)

N14 1002

PACKAGE DESCRIPTION

SW Package 16-Lead Plastic Small Outline (Wide .300 Inch) (Reference LTC DWG # 05-08-1620)

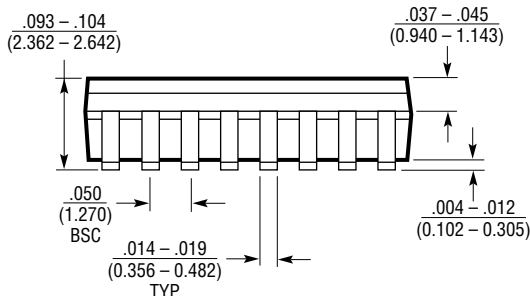
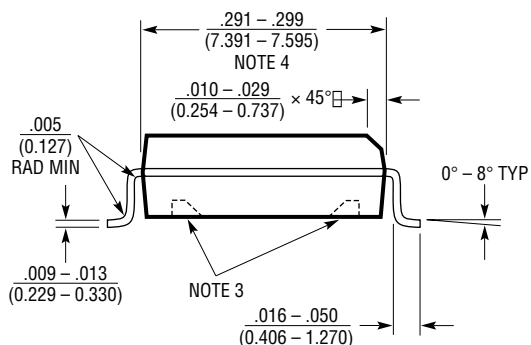
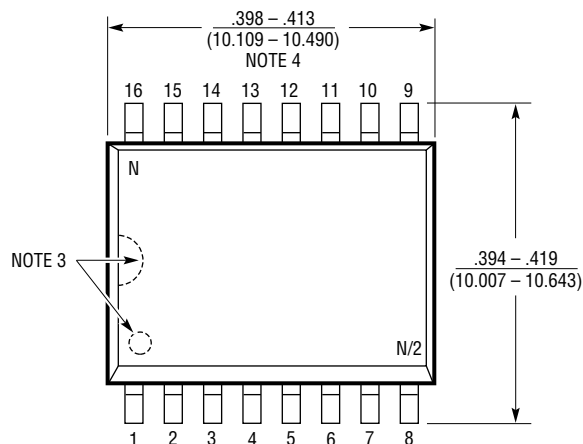
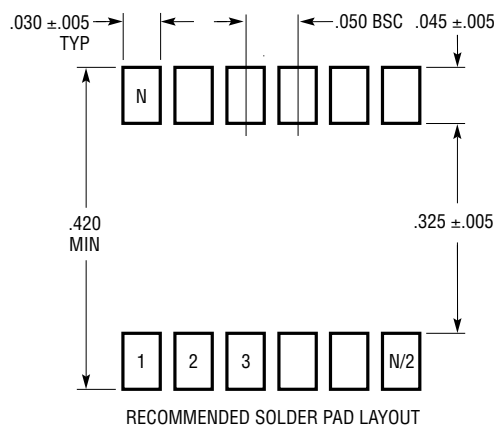

- NOTE:
1. DIMENSIONS IN $\frac{\text{INCHES}}{\text{(MILLIMETERS)}}$
 2. DRAWING NOT TO SCALE
 3. PIN 1 IDENT, NOTCH ON TOP AND CAVITIES ON THE BOTTOM OF PACKAGES ARE THE MANUFACTURING OPTIONS. THE PART MAY BE SUPPLIED WITH OR WITHOUT ANY OF THE OPTIONS
 4. THESE DIMENSIONS DO NOT INCLUDE MOLD FLASH OR PROTRUSIONS. MOLD FLASH OR PROTRUSIONS SHALL NOT EXCEED .006" (0.15mm)

S16 (WIDE) 0502

TYPICAL APPLICATIONS

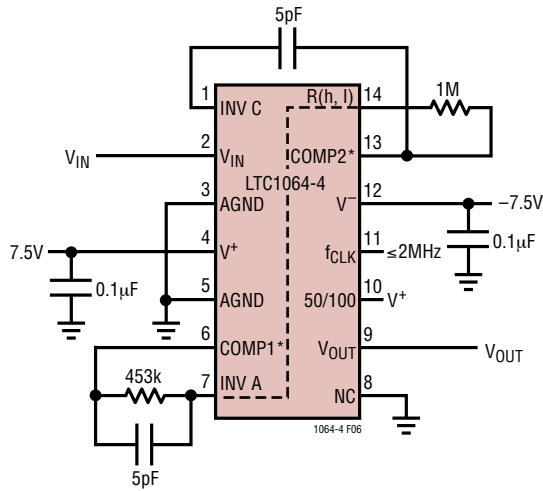

Figure 6. Compensating LTC1064-4 for Passband Ripple of $\pm 0.1\text{dB}$ and f_{CUTOFF} Sweeps to 40kHz.

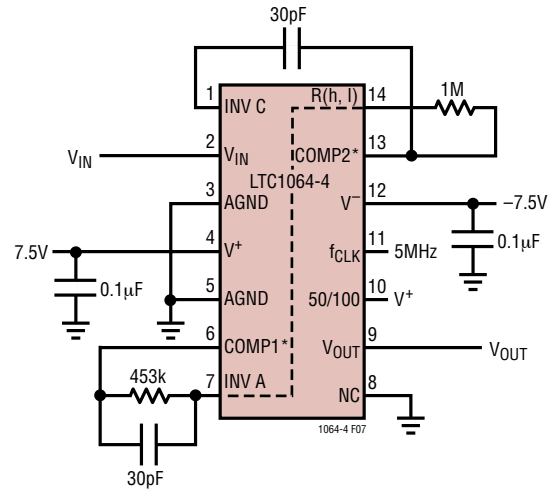

Figure 7. Compensating LTC1064-4 for $f_{\text{CUTOFF}} = 100\text{kHz}$, Gain at $f_{\text{CUTOFF}} = -1.3\text{dB}$, Table 8.

RELATED PARTS

PART NUMBER	DESCRIPTION	COMMENTS
LTC1069-1	8th Order Elliptic Lowpass	S0-8 Package, Low Power
LTC1069-6	Single Supply, 8th Order Elliptic Lowpass	S0-8 Package, Very Low Power
LTC1569-6	DC Accurate, 10th Order Lowpass	Internal Precision Clock, Low Power, S0-8 Package
LTC1569-7	DC Accurate, 10th Order Lowpass	Internal Precision Clock, Delay Equalized, S0-8 Package

X-ON Electronics

Largest Supplier of Electrical and Electronic Components

Click to view similar products for [Active Filter](#) category:

Click to view products by [Analog Devices](#) manufacturer:

Other Similar products are found below :

[1D38810GQ2](#) [1D73312GQ22](#) [1D38830GQ3](#) [D51510GQ1](#) [D45015GQ42](#) [HMC894LP5ETR](#) [HMC896LP4ETR](#) [HMC891LP5ETR](#)
[MAX7491CEE+](#) [MAX7415CUA+](#) [MAX7413CPA+](#) [MAX7411CPA+](#) [MAX7410CPA+](#) [MAX7405EPA+](#) [MAX7413CUA+](#) [MAX7411CUA+](#)
[MAX7408CPA+](#) [MAX7405CPA+](#) [MAX7401EPA+](#) [MAX293CWE+](#) [MAX281AEWE+](#) [MAX275ACPP+](#) [MAX264BEPI+](#) [MAX263BEPI+](#)
[MAX293ESA+](#) [MAX280EPA+](#) [MAX275AEPP+](#) [MAX268BCWG+](#) [MAX263AEPI+](#) [MAX7423EUA+T](#) [LT1568CGN#PBF](#)
[LTC1062CSW#PBF](#) [LTC1562CG-2#PBF](#) [HMC881LP5ETR](#) [HMC882LP5ETR](#) [HMC1000LP5ETR](#) [LTC1569CS8-6#PBF](#) [LTC1563-](#)
[2IGN#PBF](#) [MAX7426EPA+](#) [MAX7426CPA+](#) [MAX7410EPA+](#) [MAX7407EPA+](#) [MAX7407CPA+](#) [MAX7427CPA+](#) [MAX7412CPA+](#)
[MAX7404EPA+](#) [MAX7404CPA+](#) [MAX7400EPA+](#) [MAX7400CPA+](#) [MAX296EPA+](#)