

**SPECIFICATION AND USER'S MANUAL**

type of the device: 1-channel RSU KO1/2 set

the set contains: 1-channel RSU KO1/2 receiver and two 1-button PUK 101 remote controls

**TECHNICAL PARAMETERS OF THE RECEIVER**

- type of receiving module: heterodyne H1
- sensitivity: -108 dBm
- frequency: 433,92 MHz
- radio transmission: KeeLoq hopping code by Microchip Technology
- memory capacity: 113
- voltage supply:
  - nominal: 12 V DC
  - allowable: 10-15 V DC
- power consumption:
  - static: 17 mA
  - maximal: 40 mA
- capacity:
  - relay output: 1A/ 30 V DC
  - S transistor output: 0,5A/ 12 V DC
  - sabotage output: 50mA/ 12 V DC
- number of relays: 1
- relay's operating mode: mono or bistable
- time scope for the mono mode: ~1s-4min20s
- operating temperature range: -10 to +55°C
- dimensions (mm): 48\*68\*26
- cooperation: any GE sender
- operating range (m)\*: 100-500
- colour: white

\* the range depends on the type of the sender

**TECHNICAL PARAMETERS OF THE REMOTE CONTROL**

- frequency: 433,92 MHz
- transmission: coded (KeeLoq hopping code by Microchip Technology)
- number of buttons: 1
- sending power: <5mW
- power supply: 1 battery 12V
- dimensions (mm): 29\*61\*11
- colour: black
- cooperation: any GE receiver
- work range (m):
  - with H1 receiver: 150
  - with H2 receiver: 200

The operating range: the range concerns the open space (without any obstacles, when the receiver and the remote control can "see each other"). If there are any obstacles between the receiver and the sender, one must assume that the range would be reduced: for wood and plaster it would be 5-20% lower, for bricks 20-40% lower, and for reinforced concrete 40-80% lower. If there are many obstacles we advise to configure sets using the receivers of the SH class, to use retransmitters or stronger remote controls. If there are metal obstacles, using the radio systems is not recommended. In such situation, one should consider installing WLC 201 module, which helps to avoid the problem.

**USER'S MANUAL**

The purpose of the elements:

**Diode SUPPLY** control (green ZAS) – it indicates connection of the power supply

**Diode CHANNEL 1** control (red K1) – it signals that the relay is open

**Diode K2** (red) – it signals the programming procedure

**LEARNING button** – launches the programming procedures

**ANTISABOTAGE** – allows for connecting the device to the antisabotage circuit

S output – it is used to connect an acoustic signalling device which informs with short signals whether the relay is opened or closed, for example while opening the access path to the encryptor or by arming a simple alarm circuit. On opening the relay on the S output it emits one short signal, and on closing it – two signals. The maximal capacity of this output is 0,5A/12V DC, which is enough even for using sirens with a high level of audibility. The positive terminal should be connected to +12V and the negative terminal – to the S output on the terminal strip.

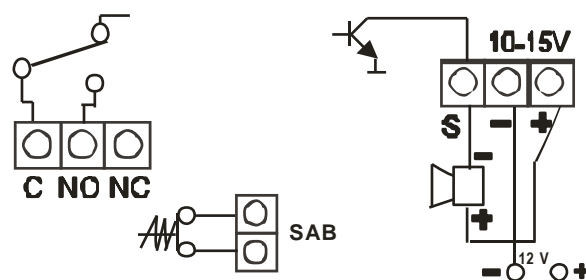
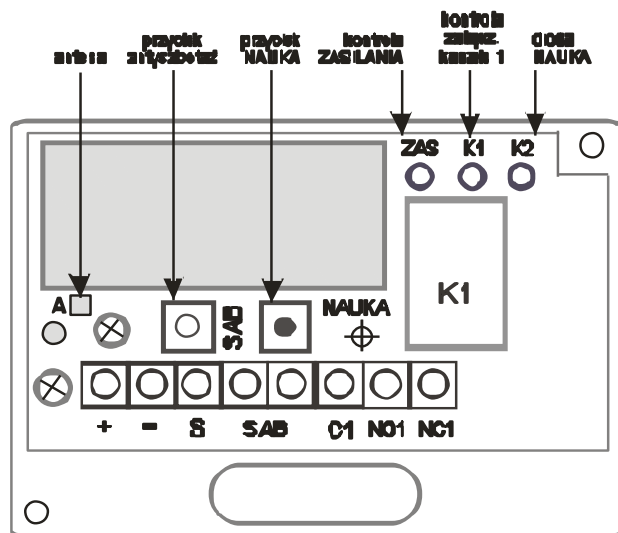

### The receiver installation conditions.

We recommend installing the receiver as high as possible, far from any metal or electric devices. The RSU-KO1 receiver requires dry and closed places.

### The transmission code.

The radio transmission, based on the hopping code (KeeLoq by Microchip Technology Inc. USA) guarantees the high safety of using. Each transmission is different from the previous one. To make the receiver work, you must enter a remote control into its memory – it is the basic condition.

The control can be programmed to unlimited number of receivers. "Loosing" 15 successive transmissions (using the control beyond the receiver's range) requires sending the signal twice (press the control button twice).

### The principal use.

The receiver can be used as equipment which controls remotely the work of the following devices: gates and barriers, electromagnetic locks, lights etc. In alarm systems it is used:

- as a panic button
- as a unit which controls the work of other devices of the system, for example, sensors
- to arm or disarm the system, zones, etc.

### Frequency.

The device works on the frequency 433,92 MHz. In majority of the European Union countries (including Poland) this bandwidth does not require any special permissions and concessions for using it.

Important! You can enter the programming mode ONLY when the relay is closed (diode K1 is off). In order to close the relay, one must press the remote control button or temporarily disconnect the supply voltage.

### **1. REGISTERING A NEW REMOTE CONTROL**

- a) press the LEARNING button for more than 0,5 but less than 4 seconds – the K2 diode will light
- b) press the button – the diode K2 will fade
- c) press the button once more – the diode K2 will light for 3 seconds, then it will start to pulse and will fade
- d) the process of registering a new remote control is finished

If the registering fails, the diode K2 will blink once and then fade. In this case, you need to start the process from the beginning. If the receiver's memory is full (113 remote controls were programmed), programming next control will delete the one which was programmed as the first. If the number of users is larger than 113, you need to use a receiver with an extended memory.

### **2. SETTING THE RECEIVER'S OPERATING MODE**

To set the receiver's operating mode, one needs to have a remote control which was previously entered into the receiver's memory (point 1.). Manufacturing settings – the bistable mode.

The monostable mode (timer) – after sending the transmission from the control, the receiver's relay will switch on pre-programmed time.

Press the LEARNING button (the diode K2 will light) and keep it pressed until the K2 diode starts to pulse – then you need to release the button. After releasing the button, the K2 diode will light with continuous light for about 4 seconds and then, slowly pulse. Each blink corresponds to one second.

For example, in order to set 20 seconds, you need to count 20 blinks of the K2 diode and press the remote control button, thus confirming the length of time. The maximal time available to set is 260s (4 min 20 s). If no button is pressed during the diode pulsing (time countdown), after counting to 260s, the K2 diode will emit continuous light for 1 minute. If during this time (the continuous lighting) the control button is pressed (confirming), the receiver will set time on the maximum, that is, about 260s. If during this time the button is NOT pressed, the receiver will quit the programming mode and will save the previous setting.

The bistable mode (flip-flop) –after receiving the transmission from the remote control, the relay flips on the other state.

Press the LEARNING button (the K2 diode will light) and keep it pressed until the K2 diode starts to pulse – then release the LEARNING button. After releasing the LEARNING button the K2 diode will emit the continuous light for about 2s and during this period one must press the control button.

### **3. DELETING THE REMOTE CONTROLS FROM THE MEMORY**

Keep the LEARNING button pressed.

Phase one: the LED K2 will light for about 4s.

Phase two: LED K2 will start to pulse and then it will fade, which means that the deletion is finished. Release the LEARNING button.

1. one must remember that deleting concerns the whole capacity of the memory. If you want to remove only one or several remote controls, you must re-enter those remote controls which are supposed to be saved.
2. If there are many users and you want to avoid the toilsome process of programming the remote controls individually, you can use one of the identifying receivers (their parameters allow for deleting the controls individually)
3. deleting the senders does not change the operating mode of the receiver
4. disconnecting the supply voltage does not cause losing the information about programmed remote controls or the operating mode of the receiver.

**The device meets the requirements of the directive EMC 89/ 336/ EEC and RTTE 1999/ 5/ EC.**



## X-ON Electronics

Largest Supplier of Electrical and Electronic Components

*Click to view similar products for [Power Management IC Development Tools](#) category:*

*Click to view products by [GORKE](#) manufacturer:*

Other Similar products are found below :

[EVAL6482H-DISC](#) [EVAL-AD5522EBUZ](#) [EVAL-ADM1060EBZ](#) [EVAL-ADM1073MEBZ](#) [EVAL-ADM1166TQEBZ](#) [EVAL-ADM1168LQEBZ](#) [EVAL-ADM1171EBZ](#) [EVAL-ADM1276EBZ](#) [EVB-EN5319QI](#) [EVB-EN5365QI](#) [EVB-EN6347QI](#) [EVB-EP5348UI](#) [MIC23158YML EV](#) [MIC23451-AAAYFL EV](#) [MIC5281YMME EV](#) [ADM00513](#) [ADM8611-EVALZ](#) [ADM8612-EVALZ](#) [ADM8613-EVALZ](#) [ADM8615-EVALZ](#) [ADP1046ADC1-EVALZ](#) [ADP1055-EVALZ](#) [ADP122-3.3-EVALZ](#) [ADP130-0.8-EVALZ](#) [ADP130-1.2-EVALZ](#) [ADP130-1.5-EVALZ](#) [ADP130-1.8-EVALZ](#) [ADP160UJZ-REDYKIT](#) [ADP166UJ-EVALZ](#) [ADP1712-3.3-EVALZ](#) [ADP1714-3.3-EVALZ](#) [ADP1715-3.3-EVALZ](#) [ADP1716-2.5-EVALZ](#) [ADP1740-1.5-EVALZ](#) [ADP1752-1.5-EVALZ](#) [ADP1754-1.5-EVALZ](#) [ADP1828LC-EVALZ](#) [ADP1870-0.3-EVALZ](#) [ADP1871-0.6-EVALZ](#) [ADP1873-0.6-EVALZ](#) [ADP1874-0.3-EVALZ](#) [ADP1876-EVALZ](#) [ADP1879-1.0-EVALZ](#) [ADP1882-1.0-EVALZ](#) [ADP1883-0.6-EVALZ](#) [ADP197CB-EVALZ](#) [ADP199CB-EVALZ](#) [ADP2102-1.25-EVALZ](#) [ADP2102-1.2-EVALZ](#) [ADP2102-1.875EVALZ](#)