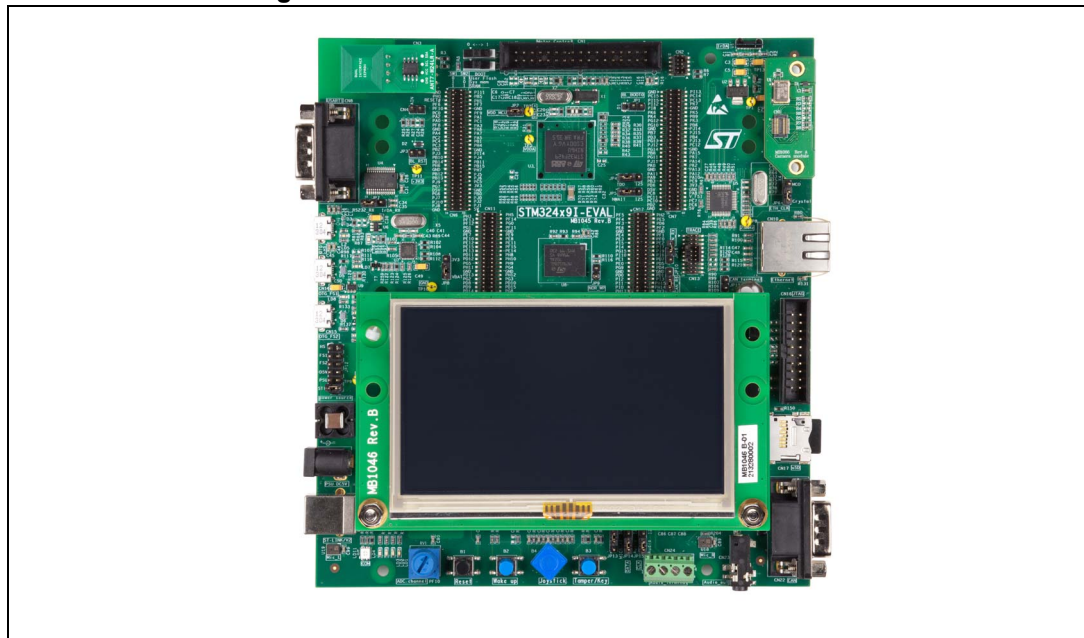

STM32429I-EVAL evaluation board for the STM32F429 line

Introduction

The STM32429I-EVAL evaluation board is a complete demonstration and development platform for STMicroelectronics ARM[®] Cortex[®]-M4 core-based STM32F429NIH6 microcontrollers. It features three I²C, six SPIs with two muxed full-duplex I²S, SDIO, four USART, four UART, two CAN, three 12-bit ADC, two 12-bit DAC, one SAI, 8- to 14-bit digital camera module interface, internal 256+4 KB SRAM and 2 MB Flash, USB HS OTG and USB FS OTG, Ethernet MAC, FMC interface, JTAG debugging support. This evaluation board can be used as a reference design for user application development but it is not considered as a final application.

The full range of hardware features on the board helps the user to evaluate all peripherals (USB OTG HS, USB OTG FS, Ethernet, Motor Control, CAN, MicroSD Card, USART, Audio DAC and ADC, digital microphone, IrDA, CAN, RF-EEPROM, SRAM, Nor Flash, SDRAM, 4.3" TFT LCD with a resistive touch panel etc.) and develop his own applications. Extension headers make it possible to easily connect a daughterboard for specific applications development.

The integrated ST-LINK/V2 provides an embedded in-circuit debugger and programmer for the STM32 MCU.

Figure 1. STM32429I-EVAL evaluation board (a)

a. Picture not contractual

Contents

- 1 Overview 6**
 - 1.1 Features 6
 - 1.2 Demonstration software 6
 - 1.3 Order code 7
 - 1.4 Delivery recommendations 7

- 2 Hardware layout and configuration 8**
 - 2.1 Development and debug support 10
 - 2.2 Power supply 11
 - 2.3 Clock source 13
 - 2.4 Reset source 13
 - 2.5 Boot option 14
 - 2.6 Audio 14
 - 2.7 USB OTG1 FS 15
 - 2.8 USB OTG2 HS & FS 16
 - 2.9 RS-232 & IrDA 16
 - 2.10 MicroSD Card 17
 - 2.11 RF-EEPROM 17
 - 2.12 CAN 17
 - 2.13 Ethernet 18
 - 2.14 Extension connector 18
 - 2.15 Memories 19
 - 2.16 Analog input 19
 - 2.17 Camera module 19
 - 2.18 Display and input devices 20
 - 2.19 Motor control 21

- 3 Connectors 24**
 - 3.1 Motor control connector CN1 24
 - 3.2 Extension connector CN2 25
 - 3.3 RF-EEPROM daughterboard connector CN3 26

3.4	Analog input connector CN4	26
3.5	Camera module connector CN5	27
3.6	Daughterboard extension connector CN6 and CN7	28
3.7	RS-232 connector CN8	33
3.8	USB OTG2 HS Micro-AB connector CN9	33
3.9	Ethernet RJ45 connector CN10	34
3.10	Memory connectors CN11 and CN12	34
3.11	ETM trace debugging connector CN13	37
3.12	USB OTG1 FS Micro-AB connector CN14	38
3.13	USB OTG2 FS Micro-AB connector CN15	38
3.14	JTAG/SWD connector CN16	39
3.15	MicroSD connector CN17	39
3.16	Power connector CN18	40
3.17	ST-LINK/V2 programming connector CN19	40
3.18	TFT LCD connector CN20	40
3.19	ST-LINK/V2 USB Type B connector CN21	41
3.20	CAN D-type 9-pin male connector CN22	41
3.21	Audio jack CN23	41
3.22	Audio terminal CN24	42
3.23	ST-LINK/V2 programming Tag-connector CN25	42
4	Schematics	43
	Appendix A STM32429I-EVAL I/O assignment	61
	Appendix B Mechanical dimensions	68
	Revision history	69

List of tables

Table 1.	Third-party toolchains	10
Table 2.	Power related jumpers	11
Table 3.	32.786 KHz crystal X1 related solder bridges.	13
Table 4.	25 MHz crystal X2 related solder bridges	13
Table 5.	Boot related switches	14
Table 6.	Audio related jumpers	15
Table 7.	USB OTG2 configuration	16
Table 8.	RS-232 & IrDA related jumper	16
Table 9.	CAN related jumpers	17
Table 10.	Ethernet related jumper	18
Table 11.	Ethernet related solder bridges.	18
Table 12.	NOR Flash related jumpers	19
Table 13.	LCD modules connector (CN20).	20
Table 14.	Motor control related solder bridges	23
Table 15.	Motor control connector CN1	24
Table 16.	Extension connector CN2.	25
Table 17.	RF-EEPROM daughterboard connector CN3.	26
Table 18.	Analog input-output connector CN4	26
Table 19.	Camera module connector CN5	27
Table 20.	Daughterboard extension connector CN6	28
Table 21.	Daughterboard extension connector CN7	30
Table 22.	RS-232 connector CN8 with ISP support	33
Table 23.	USB OTG HS Micro-AB connector CN9.	33
Table 24.	RJ45 connector CN10	34
Table 25.	Memory connector CN11	34
Table 26.	Memory connector CN12	36
Table 27.	ETM trace debugging connector CN13	37
Table 28.	USB OTG1 FS Micro-AB connector CN14	38
Table 29.	USB OTG2 FS Micro-AB connector CN15	38
Table 30.	JTAG/SWD debugging connector CN15	39
Table 31.	MicroSD connector CN17	40
Table 32.	USB type B connector CN21	41
Table 33.	CAN D-type 9-pin male connector CN22	41
Table 34.	Audio terminal CN24.	42
Table 35.	STM32429I-EVAL I/O assignment	61
Table 36.	Mechanical dimensions	68
Table 37.	Document revision history	69

List of figures

Figure 1.	STM32429I-EVAL evaluation board	1
Figure 2.	Hardware block diagram	8
Figure 3.	Evaluation board layout	9
Figure 4.	Orientation setting of 4.3 inch LCD daughterboard	21
Figure 5.	PCB underside rework for motor control	22
Figure 6.	PCB topside rework for motor control	22
Figure 7.	Motor control connector CN1 (top view)	24
Figure 8.	Extension connector CN2 top view	25
Figure 9.	RF-EEPROM daughterboard connector CN3 (front view)	26
Figure 10.	Analog input-output connector CN4 (top view)	26
Figure 11.	Camera module connector CN5 (top view)	27
Figure 12.	RS-232 connector (front view)	33
Figure 13.	USB OTG2 HS Micro-AB connector CN9 (front view)	33
Figure 14.	Ethernet RJ45 connector CN10 (front view)	34
Figure 15.	ETM trace debugging connector CN13 (top view)	37
Figure 16.	USB OTG1 FS Micro-AB connector CN14 (front view)	38
Figure 17.	USB OTG2 FS Micro-AB connector CN15 (front view)	38
Figure 18.	JTAG/SWD debugging connector CN16 (top view)	39
Figure 19.	MicroSD connector CN17 (front view)	39
Figure 20.	Power supply connector CN18	40
Figure 21.	USB type B connector CN21 (front view)	41
Figure 22.	CAN D-type 9-pin male connector CN22 (front view)	41
Figure 23.	Audio terminal CN24 (front view)	42
Figure 24.	STM32429I-EVAL	43
Figure 25.	MCU	44
Figure 26.	Power	45
Figure 27.	SRAM, Flash and SDRAM	46
Figure 28.	Audio	47
Figure 29.	LCD, camera and connectors	48
Figure 30.	Ethernet	49
Figure 31.	USB OTG HS	50
Figure 32.	USB OTG FS	51
Figure 33.	RS-232 and IrDA	52
Figure 34.	CAN, MicroSD Card and IO expander	53
Figure 35.	Peripherals	54
Figure 36.	Motor control	55
Figure 37.	Extension connector	56
Figure 38.	ST-LINK/V2	57
Figure 39.	JTAG and trace	58
Figure 40.	4.3' TFT LCD daughter board MB1046	59
Figure 41.	Camera daughterboard MB1066	60
Figure 42.	Mechanical dimensions	68

1 Overview

1.1 Features

- STM32F429NIH6 microcontroller
- Six 5 V power supply options:
 - Power jack
 - ST-LINK/V2 USB connector
 - User USB HS connector
 - User USB FS1 connector
 - User USB FS2 connector
 - Daughterboard
- SAI Audio DAC, stereo audio jack which supports headset with microphone
- Stereo digital microphone, audio terminal connector used to connect external speakers
- 2 GByte (or more) SDIO interface MicroSD Card
- RF-EEPROM on I2C compatible serial interface
- RS-232 communication
- IrDA transceiver
- JTAG/SWD and ETM trace debug support, ST-LINK/V2 embedded
- IEEE-802.3-2002 compliant Ethernet connector
- Camera module
- 8 M x 32-bit SDRAM, 1 M x 16-bit SRAM & 8 M x 16-bit NOR Flash
- 4.3 inch 480 x 272 pixel TFT LCD with resistive touch panel
- Joystick with 4-direction control and selector
- Reset, WakeUp, Tamper or key button
- 4 user color LEDs
- Extension connectors & memory connectors for daughterboard or wrapping board
- USB OTG HS and FS with Micro-AB connectors
- RTC with backup battery
- CAN2.0A/B compliant connection
- Potentiometer
- Motor control connector

1.2 Demonstration software

Demonstration software is preloaded in the Flash memory of the board for easy demonstration of the device peripherals in stand-alone mode. For more information and to download the latest version, refer to the STM32429I-EVAL demonstration software on www.st.com.

1.3 Order code

To order the evaluation board based on STM32F429NIH6 MCU and 4.3" TFT LCD, use the order code:STM32429I-EVAL1.

1.4 Delivery recommendations

Some verifications are needed before using the board for the first time to make sure that nothing was damaged during shipment and that no components are unplugged or lost.

When the board is extracted from its plastic bag, please check that no component remains in the bag.

The main components to verify are:

1. The 25 MHz crystal (X2) & 25 MHz crystal (X4) which may have been removed by a shock from its socket.
2. The MicroSD Card which may have been ejected from the connector CN17 (right side of the board).
3. The dual-interface EEPROM board (ANT7-M24LR-A) which may have been unplugged from the connector CN3 (top left corner of the board).
4. The camera module on the camera daughterboard (MB1066) which may have been unplugged.

Warning: There is an explosion risk if the battery is replaced by an incorrect one.
Make sure to dispose of used batteries according to the instructions.

2 Hardware layout and configuration

The STM32429I-EVAL evaluation board is designed around the STM32F429NIH6 (216-pin TFBGA package).

The hardware block diagram *Figure 2* illustrates the connection between the STM32F429NIH6 and peripherals (SDRAM, SRAM, NOR Flash, camera module, color LCD, USB OTG connectors, motor control connector, USART, IrDA, ethernet, audio, CAN, RF-EEPROM, MicroSD Card and embedded ST-LINK) and *Figure 3* will help the user to locate these features on the actual evaluation board.

Figure 2. Hardware block diagram

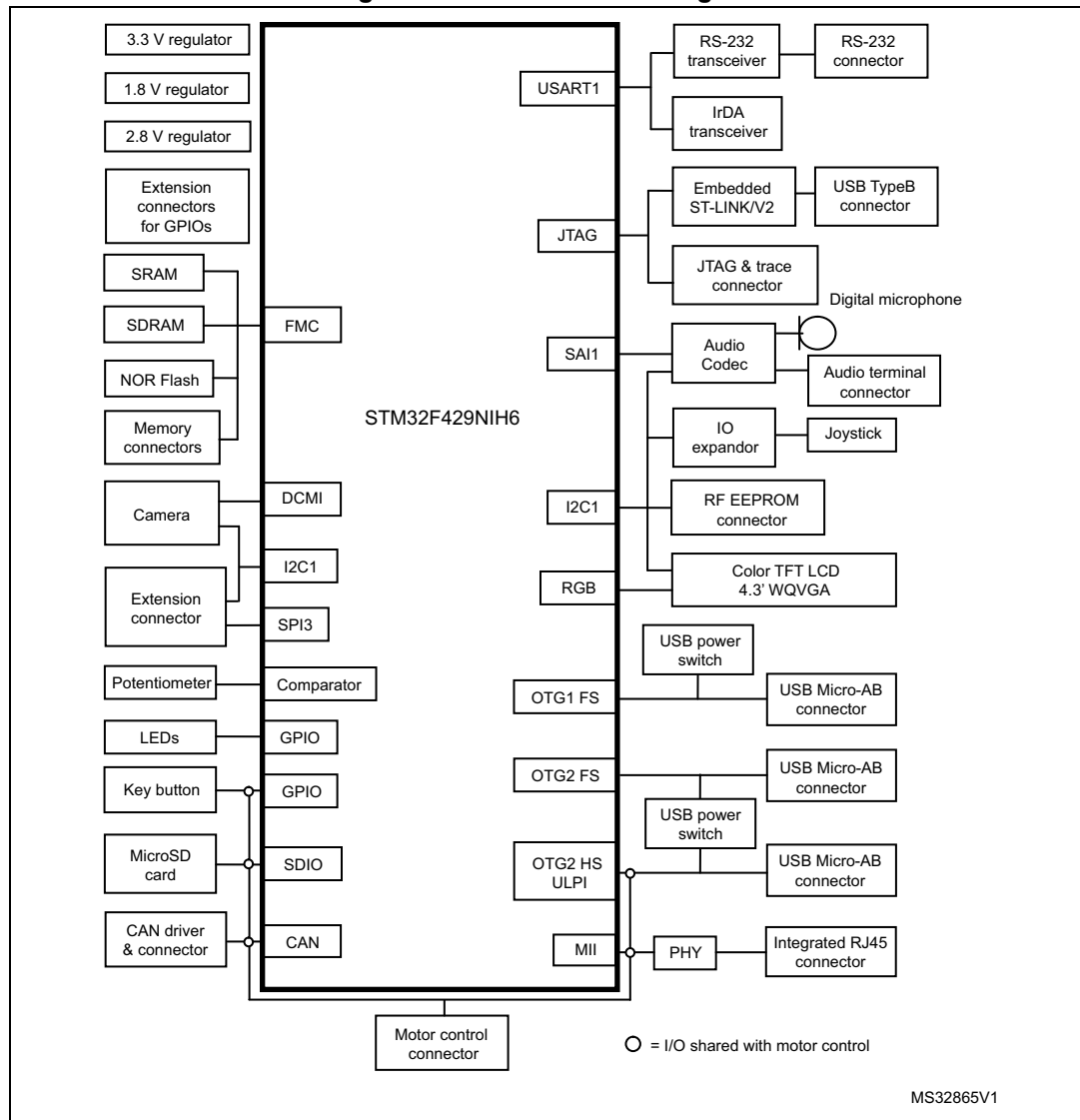
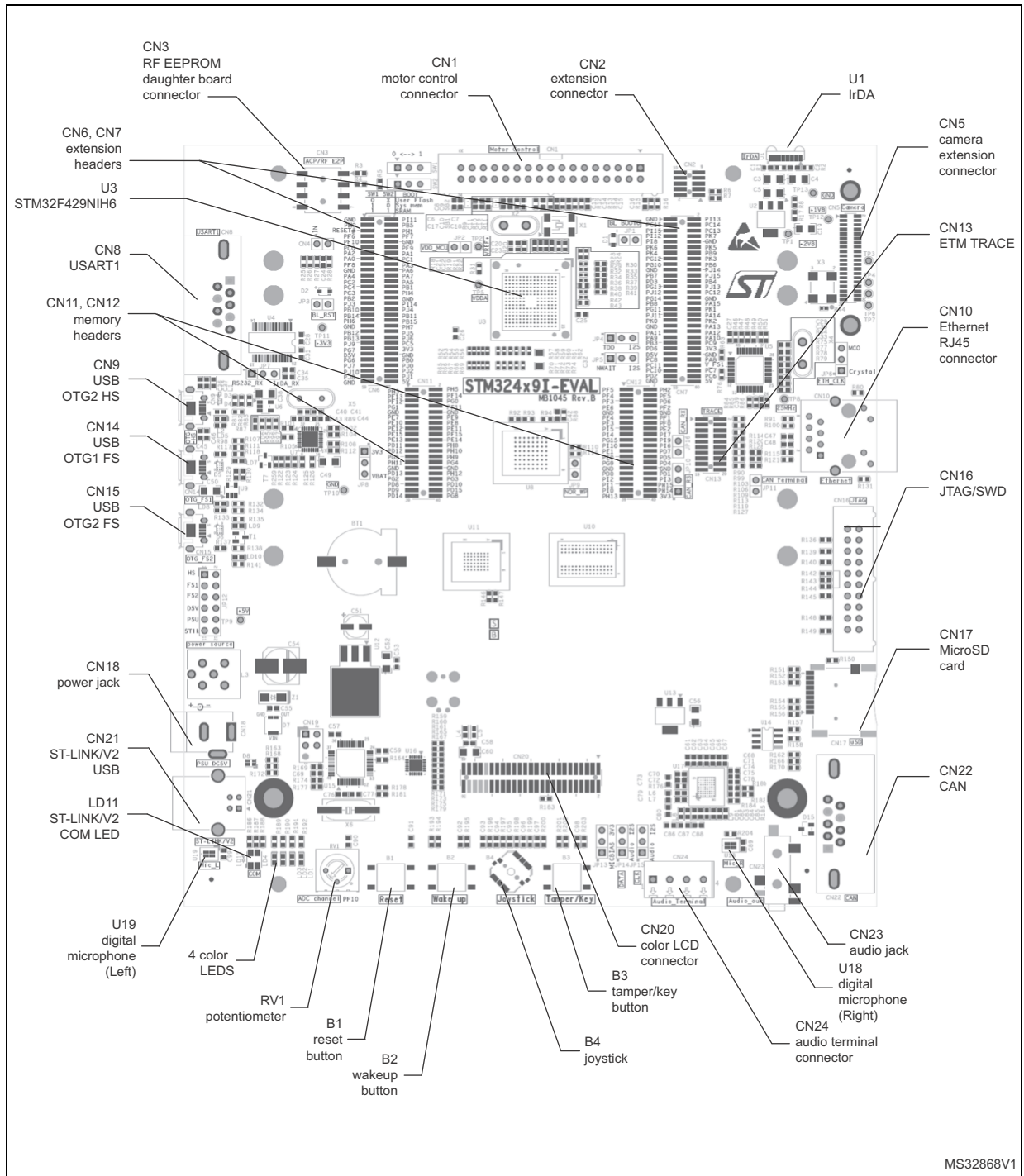

Figure 3. Evaluation board layout



2.1 Development and debug support

Version 2 of the ST-LINK (ST-LINK/V2) is embedded on the board. This tool allows on-board program loading and debugging of the STM32 using a JTAG or SWD interface. Third-party debug tools are also supported by the JTAG/SWD connector, CN16, and ETM Trace connector, CN13.

A specific driver must be installed by the user on his PC to communicate with the embedded ST-LINK/V2. An install shield called *ST-LINK_V2_USBdriver.exe* is available on the web. To download and install this driver, refer to the Software and development tools page for STM32 on www.st.com.

Third-party toolchains, ARM[®], Atollic[®] TrueSTUDIO[®], KEIL[™] MDK-ARM[™], IAR EWARM[®] and Altium[®], TASKING[™] VX-Toolset support ST-LINK/V2 according to the following table:

Table 1. Third-party toolchains

Third-party	Toolchain	Version
ARM	Atollic TrueSTUDIO	2.1
IAR	EWARM	6.20
Keil	MDK-ARM	4.20
Altium	Tasking VX-Toolset	4.0.1

The embedded ST-LINK/V2 is connected to the PC via a standard USB cable connected to connector CN21. The bicolor LED LD11 (COM) indicates the status of the communication as follows:

- Red LED slow blinking/Off: At power on before USB initialization
- Red LED fast blinking/Off: After the first correct communication between PC and ST-Link/V2 (enumeration)
- Red LED On: When initialization between PC and ST-LINK/V2 is successfully finished
- Green LED On: After successful target communication initialization
- Red/Green LED blinking: During communication with target
- Red LED On: Communication finished and OK
- Orange LED On: Communication failure

Note: *The board can be powered via CN21 (embedded ST-LINK/V2 USB connector) even if an external tool is connected to CN13 (ETM trace connector) or CN16 (external JTAG & SWD connector).*

By default ETM only works at 50 MHz clock because ETM signals are shared with other peripherals.

If best performance of ETM is required (90 MHz), then R29, R32, R34, R36, R40, R114 and R120 must be removed to reduce the stub on ETM signals. In this case SAI and camera are not functional and NOR Flash and SRAM's addresses are limited on A18.

Caution: When an external high speed debug tool connected to CN13 or CN16 is used for program loading or debugging, it is recommended to remove ESD protections D9 to D13 connected on JTAG signals.

2.2 Power supply

The STM32429I-EVAL evaluation board is designed to be powered by a 5 V DC power supply and is protected by PolyZen from a wrong power plug-in event. It is possible to configure the evaluation board to use any of following six sources for the power supply:

- 5 V DC power adapter connected to CN18, the power jack on the board (Power Supply Unit on silk screen of JP12(E5V)).
- 5 V DC power with 500 mA limitation from CN21, the USB type B connector of ST-LINK/V2 (USB 5 V power source on silkscreen of JP12(STIk)).
- 5 V DC power with 500 mA limitation from CN9, the USB OTG2 HS Micro-AB connector (USB 5V power source on silkscreen of JP12 (HS)).
- 5 V DC power with 500 mA limitation from CN14, the USB OTG1 FS Micro-AB connector (USB 5V power source on silkscreen of JP12 (FS1)).
- 5 V DC power with 500 mA limitation from CN15, the USB OTG2 FS Micro-AB connector (USB 5 V power source on silkscreen of JP12 (FS2)).
- 5 V DC power from CN6 & CN7, the extension connectors for daughterboard (Daughterboard power source on silkscreen of JP12 (D5V)).

The power supply is configured by setting the related jumpers JP2, JP8 and JP12 as described in [Table 2](#).

Table 2. Power related jumpers







Jumper	Description													
JP2	JP2 is used to measure MCU current consumption manually by multimeter. Default setting: Fitted													
JP8	Vbat is connected to +3.3V when JP8 is set as shown to the right: (Default setting)													
	Vbat is connected to battery when JP8 is set as shown to the right:													
JP12 (continued on next page)	JP12 is used to select one of the six possible power supply resources. For power supply from USB connector of ST-LINK/V2 (CN21) to STM32429I-EVAL only, JP12 is set as shown to the right: (Default setting)	<table style="border: none;"> <tr><td>HS</td><td>● ●</td></tr> <tr><td>FS1</td><td>● ●</td></tr> <tr><td>FS2</td><td>● ●</td></tr> <tr><td>D5V</td><td>● ●</td></tr> <tr><td>PSU</td><td>● ●</td></tr> <tr><td>STIk</td><td>● ●</td></tr> </table>	HS	● ●	FS1	● ●	FS2	● ●	D5V	● ●	PSU	● ●	STIk	● ●
	HS	● ●												
	FS1	● ●												
FS2	● ●													
D5V	● ●													
PSU	● ●													
STIk	● ●													
For power supply jack (CN18) to the STM32429I-EVAL only, JP12 is set as shown to the right:	<table style="border: none;"> <tr><td>HS</td><td>● ●</td></tr> <tr><td>FS1</td><td>● ●</td></tr> <tr><td>FS2</td><td>● ●</td></tr> <tr><td>D5V</td><td>● ●</td></tr> <tr><td>PSU</td><td>● ●</td></tr> <tr><td>STIk</td><td>● ●</td></tr> </table>	HS	● ●	FS1	● ●	FS2	● ●	D5V	● ●	PSU	● ●	STIk	● ●	
HS	● ●													
FS1	● ●													
FS2	● ●													
D5V	● ●													
PSU	● ●													
STIk	● ●													
For power supply from the daughterboard connectors (CN6 & CN7) to STM32429I-EVAL only, JP12 is set as shown to the right:	<table style="border: none;"> <tr><td>HS</td><td>● ●</td></tr> <tr><td>FS1</td><td>● ●</td></tr> <tr><td>FS2</td><td>● ●</td></tr> <tr><td>D5V</td><td>● ●</td></tr> <tr><td>PSU</td><td>● ●</td></tr> <tr><td>STIk</td><td>● ●</td></tr> </table>	HS	● ●	FS1	● ●	FS2	● ●	D5V	● ●	PSU	● ●	STIk	● ●	
HS	● ●													
FS1	● ●													
FS2	● ●													
D5V	● ●													
PSU	● ●													
STIk	● ●													

Table 2. Power related jumpers (continued)

Jumper	Description												
JP12 (continued)	For power supply from USB OTG2 FS (CN15) to STM32429I-EVAL only, JP12 is set as shown to the right: <div style="float: right; text-align: right;"> <table style="border-collapse: collapse;"> <tr><td>HS</td><td>●●</td></tr> <tr><td>FS1</td><td>●●</td></tr> <tr><td>FS2</td><td>●●</td></tr> <tr><td>D5V</td><td>●●</td></tr> <tr><td>PSU</td><td>●●</td></tr> <tr><td>STIk</td><td>●●</td></tr> </table>  </div>	HS	●●	FS1	●●	FS2	●●	D5V	●●	PSU	●●	STIk	●●
	HS	●●											
	FS1	●●											
	FS2	●●											
D5V	●●												
PSU	●●												
STIk	●●												
For power supply from USB OTG1 FS (CN14) to STM32429I-EVAL only, JP12 is set as shown to the right: <div style="float: right; text-align: right;"> <table style="border-collapse: collapse;"> <tr><td>HS</td><td>●●</td></tr> <tr><td>FS1</td><td>●●</td></tr> <tr><td>FS2</td><td>●●</td></tr> <tr><td>D5V</td><td>●●</td></tr> <tr><td>PSU</td><td>●●</td></tr> <tr><td>STIk</td><td>●●</td></tr> </table>  </div>	HS	●●	FS1	●●	FS2	●●	D5V	●●	PSU	●●	STIk	●●	
HS	●●												
FS1	●●												
FS2	●●												
D5V	●●												
PSU	●●												
STIk	●●												
For power supply from USB OTG2 HS (CN9) to STM32429I-EVAL only, JP12 is set as shown to the right: <div style="float: right; text-align: right;"> <table style="border-collapse: collapse;"> <tr><td>HS</td><td>●●</td></tr> <tr><td>FS1</td><td>●●</td></tr> <tr><td>FS2</td><td>●●</td></tr> <tr><td>D5V</td><td>●●</td></tr> <tr><td>PSU</td><td>●●</td></tr> <tr><td>STIk</td><td>●●</td></tr> </table>  </div>	HS	●●	FS1	●●	FS2	●●	D5V	●●	PSU	●●	STIk	●●	
HS	●●												
FS1	●●												
FS2	●●												
D5V	●●												
PSU	●●												
STIk	●●												
For power supply from power supply jack(CN18) to both STM32429I-EVAL and daughterboard connected on CN6 & CN7, JP12 is set as shown to the right (daughterboard must not have its own power supply connected) <div style="float: right; text-align: right;"> <table style="border-collapse: collapse;"> <tr><td>HS</td><td>●●</td></tr> <tr><td>FS1</td><td>●●</td></tr> <tr><td>FS2</td><td>●●</td></tr> <tr><td>D5V</td><td>●●</td></tr> <tr><td>PSU</td><td>●●</td></tr> <tr><td>STIk</td><td>●●</td></tr> </table>  </div>	HS	●●	FS1	●●	FS2	●●	D5V	●●	PSU	●●	STIk	●●	
HS	●●												
FS1	●●												
FS2	●●												
D5V	●●												
PSU	●●												
STIk	●●												

The LED LD10 is lit when the STM32429I-EVAL evaluation board is powered by the 5 V correctly.

Note:

In order to avoid the impact of USB PHY and Ethernet PHY and get precise results of current consumption on JP2, the following configurations must be implemented:

- Configure Ethernet PHY in Power Down Mode by setting low level of IO_Expander (EXP_IO1).
- Configure USB HS PHY in Low Power Mode (Register Address=04,bit 6 in USB PHY).

2.3 Clock source

Two clock sources are available on the STM32429I-EVAL evaluation board for the STM32F429NIH6 and embedded RTC.

The camera module, ethernet PHY and USB PHY on the STM32429I-EVAL evaluation board have their own clock sources.

- X1, 32.768 KHz crystal for embedded RTC.
- X2, 25 MHz crystal with socket for STM32F429NIH6 microcontroller, it can be removed from the socket when an internal RC clock is used.
- X3, 24 MHz oscillator for camera module.
- X4, 25 MHz crystal with socket for ethernet PHY.
- X5, 24 MHz crystal for USB OTG2 HS PHY.

Table 3. 32.786 KHz crystal X1 related solder bridges

Solder bridge	Description
SB3	PC14 is connected to 32.786 KHz crystal when SB3 is open. (Default setting)
	PC14 is connected to extension connector CN7 when SB3 is closed. In such case R19 must be removed to avoid disturbance due to the 32.786 KHz quartz.
SB4	PC15 is connected to 32.786 KHz crystal when SB4 is open. (Default setting)
	PC15 is connected to extension connector CN7 when SB4 is closed. In such case R18 must be removed to avoid disturbance due to the 32.786 KHz quartz.

Table 4. 25 MHz crystal X2 related solder bridges

Solder bridge	Description
SB5	PH0 is connected to 25 MHz crystal when SB5 is open. (Default setting)
	PH0 is connected to extension connector CN6 when SB5 is closed. In such case R20 must be removed to avoid disturbance due to the 25 MHz quartz
SB6	PH1 is connected to 25 MHz crystal when SB6 is open (Default setting).
	PH1 is connected to extension connector CN7 when SB6 is closed. In such case C23 & X2 must be removed to avoid disturbance due to the 25 MHz quartz.

Jumper JP6 for Ethernet clock refer to [Section 2.13](#).

2.4 Reset source

The reset signal of STM32429I-EVAL evaluation board is low active. Reset sources include:

- Reset button B1
- Debugging tools from JTAG/SWD connector CN16 and ETM trace connector CN13
- Daughterboard from CN6
- Embedded ST-LINK/V2





2.5 Boot option

The STM32429I-EVAL evaluation board can boot from:

- Embedded user Flash
- System memory with boot loader for ISP
- Embedded SRAM for debugging

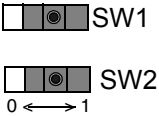
The boot option is configured by setting switch SW1 (BOOT0) and SW2 (BOOT1).

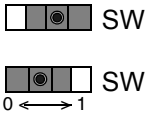
Table 5. Boot related switches

Switch	Boot description	Switch configuration
SW1 & SW2	STM32429I-EVAL boots from User Flash when SW1 is set as shown to the right. SW2 is not required in this configuration. (Default setting)	 SW1 0 ←→ 1
	STM32429I-EVAL boots from Embedded SRAM when SW1 and SW2 are set as shown to the right.	 SW1  SW2 0 ←→ 1
	STM32429I-EVAL boots from System Memory when SW1 and SW2 are set as shown to the right.	 SW1  SW2 0 ←→ 1

Note: The RS-232 boot loader mechanism is not supported on the STM32429I-EVAL.

2.6 Audio











An audio codec WM8994ECS/R with 4 DACs and 2 ADCs inside is connected to the SAI interface of the STM32F429NIH6 to support the TDM feature on the SAI port. This feature implements audio recording on digital and analog microphone, and audio playback of different audio streams on headphone and line-out at the same time.

It communicates with the STM32F429NIH6 via the I2C1 bus which is shared with the LCD, camera module, RF-EEPROM, IO expander and CN2 connector.

The analog microphone on the headset is connected to the ADC of WM8994ECS/R. External speakers can be connected to WM8994ECS/R via audio terminal connector CN24.

There are two digital microphones (MEMs microphone) MP34DT01TR on the STM32429I-EVAL evaluation board. They can be connected to either audio codec or the I2S port of STM32F429NIH6 by setting jumpers as shown in [Table 6](#).

Table 6. Audio related jumpers

Jumper	Description	
JP14	Data signal on digital microphone is connected to audio codec when JP14 is set as shown to the right (Default setting)	
	Data signal on digital microphone is connected to I2S port of STM32F429NIH6 when JP14 is set as shown to the right (also need to set JP5 according to this table)	
JP15	Clock signal on digital microphone is connected to audio codec when JP15 is set as shown to the right (Default setting)	
	Clock signal on digital microphone is connected to Timer output (PC7) of STM32F429NIH6 when JP15 is set as shown to the right (also need to set JP4 according to this table)	
JP4	PB4 is as TDO/SWO signal when JP4 is set as shown to the right (Default setting)	
	PB4 is connected to Timer input(PC6) of STM32F429NIH6 as I2S clock signal when JP4 is set as shown to the right (also need to set JP15 according to this table)	
JP5	PD6 is as FMC_NWAIT signal when JP5 is set as shown to the right (Default setting)	
	PD6 is connected to digital microphone as I2S data signal when JP5 is set as shown to the right (also need to set JP14 according to this table):	
JP13	Digital microphone power source is connected to +3.3V power when JP13 is set as shown to the right	
	Digital microphone power source is connected to MICBIAS1 from WM8994ECS/R when JP13 is set as shown to the right. MICBIAS1 setting is requested by digital microphone connected to Codec. (Default setting)	

Note: The I2C address of WM8994ECS/R is 0b0011010.

2.7 USB OTG1 FS

The STM32429I-EVAL evaluation board supports USB OTG1 full speed communication via a USB Micro-AB connector (CN14) and USB power switch (U9) connected to VBUS. The evaluation board can be powered by this USB connection at 5 V DC with a 500 mA current limitation.

Green LED LD7 will be lit in one of these cases:

- Power switch (U9) is ON and the STM32429I-EVAL is acting as a USB host.
- VBUS is powered by another USB host and the STM32429I-EVAL is acting as a USB device.

Red LED LD8 will be lit when over-current occurs.

JP16 must be removed when using USB OTG FS as mentioned in [Table 9](#).

2.8 USB OTG2 HS & FS

The STM32429I-EVAL evaluation board supports USB OTG2:

- High speed communication via USB Micro-AB connector (CN9), USB high speed PHY (U7) for high speed function
- Full speed communication via USB Micro-AB connector (CN15)

The evaluation board can be powered by these USB connectors (CN9 or CN15) at 5 V DC with a 500 mA current limitation.

Some OTG2 FS signals are shared with the OTG2 HS ULPI bus, so some PCB rework is needed when using OTG2 FS (CN15) as shown in [Table 7](#).

Table 7. USB OTG2 configuration

Function	Mount	Remove
OTG2 HS-CN9 (Default)	R108, R112, R81,R97	R260, R264, R83,R95
OTG2 FS-CN15	R260, R264, R83,R95	R108, R112, R81,R97

A USB power switch (U6) is connected on VBUS and provides power to either:

- CN9 (with R81 & R97 mounted and R83 & R95 un-mounted)
- CN15 (with R83 & R95 mounted and R81& R97 un-mounted)

Green LED LD5 (for CN9) or LD9 (for CN15) will be lit when either:

- Power switch (U6) is ON and STM32429I-EVAL is acting as a USB host.
- VBUS is powered by another USB host, and STM32429I-EVAL is acting as a USB device.

Red LED LD6 is lit if over-current occurs.

2.9 RS-232 & IrDA

RS-232 and IrDA communication is supported by 9-pin RS-232 D-type connector, CN8, and IrDA transceiver, U1, which is connected to USART1 of the STM32F429NIH6 on the STM32429I-EVAL evaluation board.

Table 8. RS-232 & IrDA related jumper

Jumper	Description
JP7	USART1_RX is connected to RS-232 transceiver and RS-232 communication is enabled when JP7 is set as shown to the right (Default setting):
	USART1_RX is connected to IrDA transceiver and IrDA communication is enabled when JP7 is set as shown to the right:



2.10 MicroSD Card

A 2 GB (or more) MicroSD Card can be connected to the STM32F429NIH6 SDIO port. MicroSD Card detection is managed by I/O expander GPIO15.

2.11 RF-EEPROM

An RF-EEPROM daughterboard ANT7-M24LR-A is mounted on CN3 of the STM32429I-EVAL board via the I2C1 bus. The RF-EEPROM can be accessed by the microcontroller via the I2C1 bus or by radio frequency (RF) using a 13.56 MHz reader (for example, CR95HF).



The I2C address of RF-EEPROM is 0b1010000.

2.12 CAN

The STM32429I-EVAL evaluation board supports one channel of CAN2.0A/B complaint CAN bus communication based on 3.3 V CAN transceiver.

High-speed mode, standby mode and slope control mode are available and are selected by setting JP10.

Table 9. CAN related jumpers

Jumper	Description
JP10	CAN transceiver is working in standby mode when JP10 is set as shown to the right: 
	CAN transceiver is working in high-speed mode when JP10 is set as shown to the right: (default setting) 
	CAN transceiver is working in slope control mode when JP10 is open.
JP11	CAN terminal resistor is enabled when JP11 is fitted. Default setting: Not fitted
JP16	PA11 is only connected with USB FS1 DM signal when JP16 is fitted. (default setting)
	PA11 is connected with CAN RX signal when JP16 is fitted. If the CAN function is being used, USB connector CN14 should be disconnected to leave USB FS1_DM signal floating.

2.13 Ethernet

The STM32429I-EVAL evaluation board supports 10M/100M Ethernet communication by a PHY DP83848CVV (U5) and integrated RJ45 connector (CN10). Ethernet PHY is connected to the STM32F429NIH6 via the MII interface.

A 25 MHz clock can be generated by PHY or provided by MCO from the STM32F429NIH6 by setting jumper JP6 as shown in [Table 10](#).

Table 10. Ethernet related jumper



Jumper	Description
JP6	25 MHz clock is provided by external Crystal X4 when JP5 is set as shown to the right: (Default setting) 
	25 MHz clock for MII is provided by MCO at PA8 when JP5 is set as shown to the right: 

Table 11. Ethernet related solder bridges

Solder bridges	Description
SB7	MII CRS on DP83848CVV is connected to PA0 when SB7 is closed. PA0 is shared with Wakeup button and MC_ENA. Default setting: Open
SB8	MII COL on DP83848CVV is connected to PH3 when SB8 is closed. PH3 is shared with SDRAM chip select SDNE0. Default setting: Open

Note: Ethernet works properly in the default setting (which RX_ER is not connected to P110 of STM32F429NIH6) because P110 is shared with data signal of SDRAM. If RX_ER signal is needed, remove R244 and solder R43.

2.14 Extension connector

An extension connector (CN2) is intended for external board connection to the STM32429I-EVAL evaluation board using cable FFSD-05-D-04.00-01-N.

The external board can exchange data with the STM32F429NIH6 via the I2C1 or SPI3 ports.

2.15 Memories

8 M x 32-bit SDRAM is connected to SDRAM Bank1 of the STM32F429NIH6 FMC interface.

1 Mbit x 16 SRAM is connected to bank1 NOR/PSRAM2 of the FMC interface and both 8-bit and 16-bit access is allowed by BLN0 & BLN1 connected to BLE & BHE of SRAM respectively.

128 Mbit NOR Flash is connected to bank1 NOR/PSRAM1 of the FMC interface. The 16-bit operation mode is selected by the pull-up resistor connected to BYTE pin of NOR Flash. Write protection is enabled or disabled by the setting of jumper JP9:

Table 12. NOR Flash related jumpers

Jumper	Description
JP9	Write protection is enabled when JP9 is fitted while write protection is disabled when JP9 is not fitted. Default Setting: Not fitted
JP5	Description of JP5 is in Section 1.6: Audio

All memory signals are also connected on memory connectors CN11 and CN12 for memory daughterboards.

Some limitations occur when using other peripherals:

1. FMC addressing limitation depending on number of trace data buses used (A18 max for 4-bit ETM to A21 max for 1-bit ETM).
2. NOR Flash addresses limited to A21 when SAI or camera module is used.

In such cases, memory addresses A18 to A21 not connected to FMC are pulled down so memories can be addressed within a limited address range. If A22 is required, the camera board should be removed and SAI1_SDA should be tri-stated. AIF1_TRI (address: 0x300) bit 13 of the W8994 can be used to tri-state ADCDAT1 pin (SAI1_SDA) when it is set to 1.

2.16 Analog input

The two-pin header CN4, and 10 Kohm potentiometer RV1, are connected to PF10 of the STM32F429NIH6 as analog input. A low pass filter can be implemented by replacing R27 and C24 with the resistor and capacitor requested by end user's application.

2.17 Camera module

Connector CN5 (for DCMI signals) on the STM32429I-EVAL evaluation board connects to the camera module daughterboard MB1066.

DCMI signals are duplicated with other peripherals (SAI, I2S, NOR Flash, MicroSD Card, Trace, Ethernet).

These peripherals may not function correctly when the camera module is being used. To avoid SAI1_SDA signal impacting D7, SAI1_SDA should be tri-stated.

Refer to [Section 2.15](#) to see how to tri-state SAI1_SDA.

2.18 Display and input devices

A 4.3 inch 480x272 TFT color LCD with resistive touch panel can be connected to the RGB LCD interface of STM32F429NIH6.

4 general purpose color LED's (LD 1,2,3,4) are available as display devices.

The 4-direction joystick (B4), Wakeup (B2) and Tamper/key button (B3) are available as input devices.

Table 13. LCD modules connector (CN20)

Pin No.	Description	Pin connection	Pin No.	Description	Pin connection
1	GND	-	2	GND	-
3	R0	PI15	4	G0	PJ7
5	R1	PJ0	6	G1	PJ8
7	R2	PJ1	8	G2	PJ9
9	R3	PJ2	10	G3	PJ10
11	R4	PJ3	12	G4	PJ11
13	R5	PJ4	14	G5	PK0
15	R6	PJ5	16	G6	PK1
17	R7	PJ6	18	G7	PK2
19	GND	-	20	GND	-
21	B0	PJ12	22	ENB	PK7
23	B1	PJ13	24	-	-
25	B2	PJ14	26	HSYNC	PI12
27	B3	PJ15	28	VSYNC	PI13
29	B4	PK3	30	GND	-
31	B5	PK4	32	CLK	PI14
33	B6	PK5	34	GND	-
35	B7	PK6	36	RESET#	-
37	GND	-	38	I2C1_SDA	PB9
39	INT	IO EXPANDER GPIO4	40	I2C1_SCL	PB6
41	-	-	42	-	-
43	BL_CTRL	PA8	44	-	-
45	5V	-	46	-	-
47	BLGND	-	48	-	-
49	BLGND	-	50	3.3V	-

Note: On 4.3-inch daughterboard, `BL_CTRL` (PA8) can be used to manage on/off of backlight if needed.

Because `BL_CTRL` is shared with `MII_MCO` which is in default setting, `R279` must be removed and `R283` must be soldered with a 0 ohm resistor.

The orientation setting of 4.3 inch LCD daughterboard can be changed by hinged standoffs and pillars. There are two possible orientations according to holes on the motherboard and LCD daughterboard. Refer to [Figure 4](#) for details.

Figure 4. Orientation setting of 4.3 inch LCD daughterboard

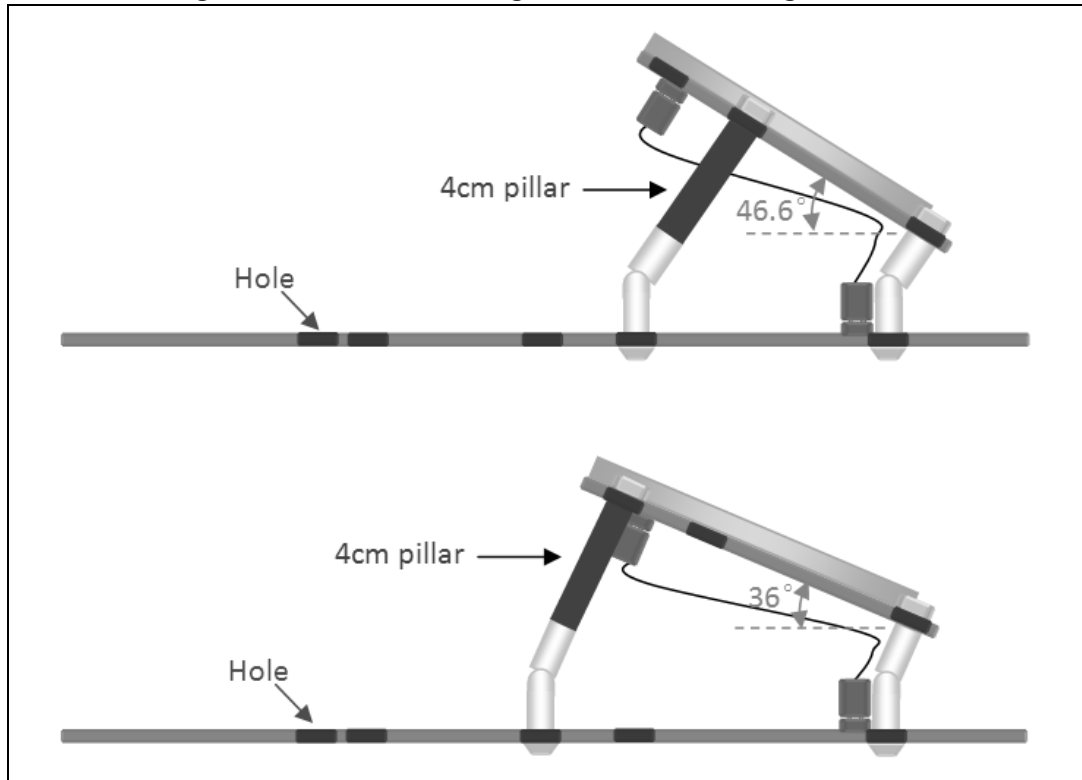

2.19 Motor control

The STM32429I-EVAL evaluation board supports both asynchronous and synchronous three-phase brushless motor control via a 34-pin connector, CN1, which provides all required control and feedback signals to and from motor power-driving board.

Available signals on this connector include emergency stop, motor speed, 3 phase motor current, bus voltage, heatsink temperature coming from the motor driving board and 6 channels of PWM control signal going to the motor driving circuit.

Some PCB rework is needed for motor control application to disconnect peripherals which share I/Os with motor control connector and connect these I/Os to Motor control connector.

- Remove R219, R214, R211, R227, R283, R279, R256, R261, R102, R104, R243, R222, R228, R238, R239, R267, R281, R249, SB7, JP4 (no jumper on pin 2-3), JP15 (no jumper on pin 2-3), JP16.
- Mount R16, R223, R210, R215, R225, R268, R255, R252, R282, R234, R240, R218, R232, R242, R235, R263, R292, R280, R246 with 0 ohm resistors.

All resistors to be removed on the underside of the board are marked in red, while resistors to be soldered are marked in green in *Figure 5*.

Figure 6 shows all resistors to be removed on the topside of the board marked in red, while resistors to be soldered are marked in green (removal of R102 and R104, and mounting of R16).

Figure 5. PCB underside rework for motor control

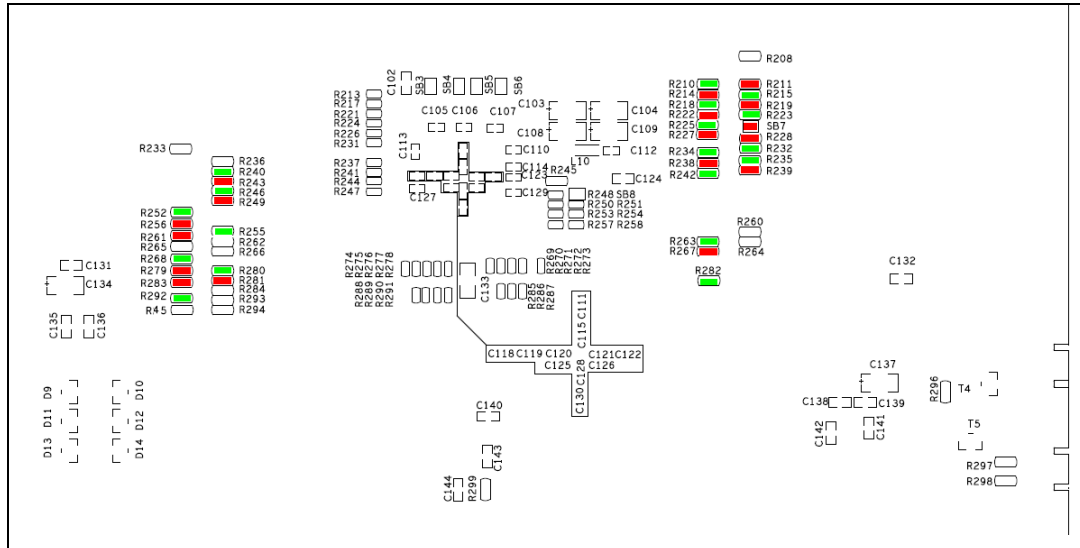

Figure 6. PCB topside rework for motor control

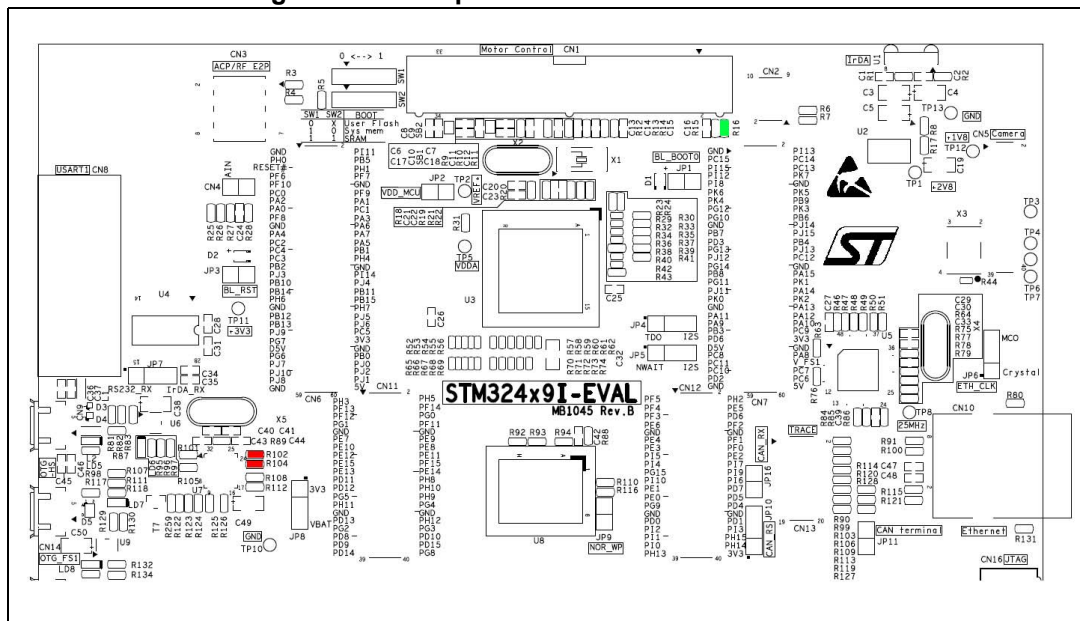

Table 14. Motor control related solder bridges

Solder bridges	Description
SB1	The special motor current sampling operation is enabled when SB1 is closed (PA12 connected to PA8). The I/O pins PA12 and PA8 are disconnected and can be used by a daughterboard when SB1 is not fitted. Default setting: Open
SB2	SB2 should be kept on open when encoder signal is from pin31 of motor control connector CN1, while it should be kept on close when analog signal is from pin31 of CN1 for a special motor. Default setting: Open

3 Connectors

3.1 Motor control connector CN1

Figure 7. Motor control connector CN1

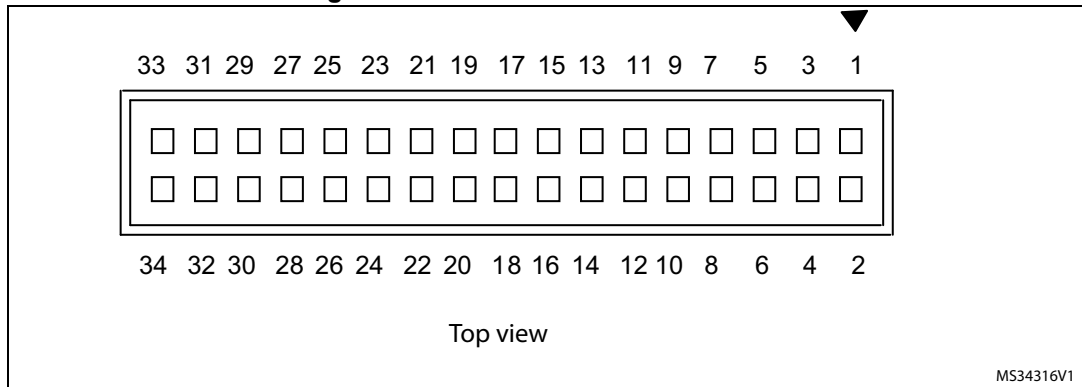

Table 15. Motor control connector CN1

Description	STM32F429NIH6 pin	CN1 pin number	CN1 pin number	STM32F429NIH6 pin	Description
Emergency stop	PA6	1	2	-	GND
MC_UH	PC6	3	4	-	GND
MC_UL	PA7	5	6	-	GND
MC_VH	PC7	7	8	-	GND
MC_VL	PB0	9	10	-	GND
MC_WH	PC8	11	12	-	GND
MC_WL	PB1	13	14	PC4	Bus voltage
current A	PC1	15	16	-	GND
current B	PC2	17	18	-	GND
current C	PC3	19	20	-	GND
NTC bypass relay	PG11	21	22	-	GND
Dissipative brake PWM	PB8	23	24	-	GND
+5V power	-	25	26	PC5	Heatsink temperature
PFC sync	PA12 & PA8. See Table 14 for detail	27	28	-	3.3V power
PFC PWM	PA11	29	30	-	GND
Encoder A	PA0	31	32	-	GND
Encoder B	PA1	33	34	PA2	Encoder Index

3.2 Extension connector CN2

Figure 8. Extension connector CN2 top view

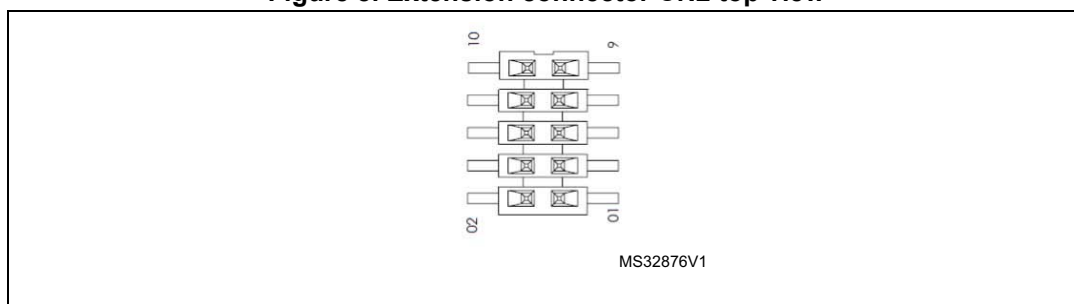

Table 16. Extension connector CN2

Pin number	Pin name	I2C interface description	SPI interface description
1	PB9	I2C1_SDA	SPI3_CS
2	PC11	-	SPI3_MISO
3	PB6	I2C1_SCL	EXT_RESET
4	PC10	EXT_RESET	SPI3_SCK
5	NC	-	-
6	PC12	-	SPI3_MOSI
7	GND	-	-
8	+5V	-	-
9	NC	-	-
10	NC	-	-

3.3 RF-EEPROM daughterboard connector CN3

Figure 9. RF-EEPROM daughterboard connector CN3 (front view)

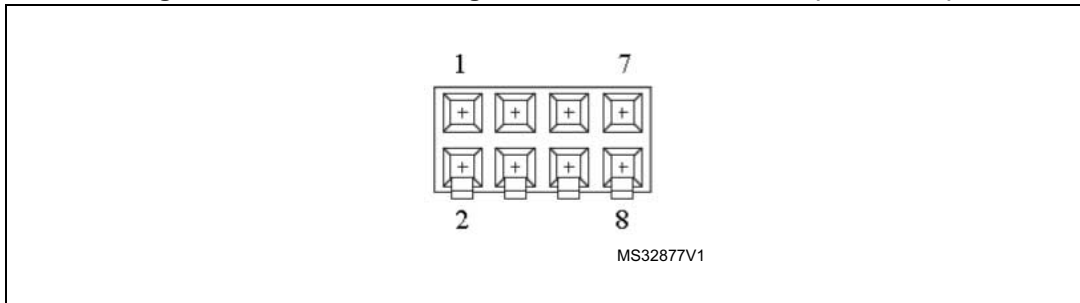

Table 17. RF-EEPROM daughterboard connector CN3

Pin number	Description	Pin number	Description
1	I2C1_SDA (PB9)	5	+3V3
2	SPI3_MISO (PC11)	6	Reserved for future use (PC12)
3	I2C1_SCL (PB6)	7	GND
4	RESET(PC10)	8	+5V

3.4 Analog input connector CN4

Figure 10. Analog input-output connector CN4 (top view)

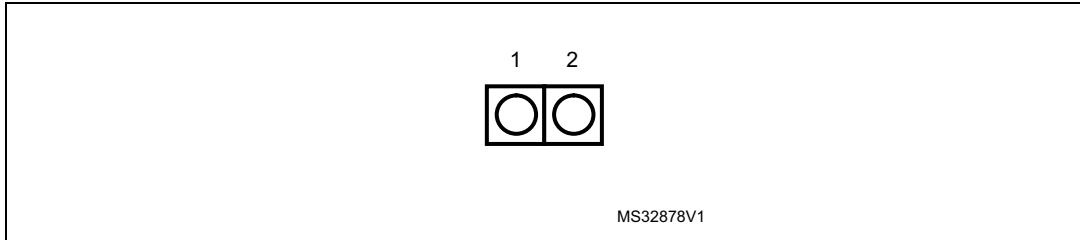

Table 18. Analog input-output connector CN4

Pin number	Description	Pin number	Description
1	Analog input-output (PF10)	2	GND

3.5 Camera module connector CN5

Figure 11. Camera module connector CN5 (top view)

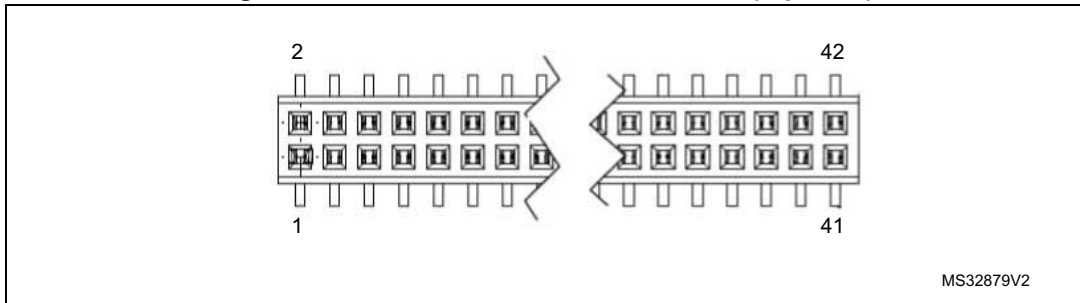

Table 19. Camera module connector CN5

Pin number	Description	Pin number	Description
1	+1.8 V	22	GND
2	+1.8 V	23	D0 (PC6)
3	GND	24	D1 (PC7)
4	GND	25	D2 (PC8)
5	D10 (PD6)	26	D3 (PC9)
6	D11 (PD2)	27	D4 (PC11)
7	GND	28	D5(PD3)
8	GND	29	D6(PB8)
9	D8(PC10)	30	D7(PE6)
10	D9(PC12)	31	HSYNC(PA4)
11	GND	32	VSYNC(PB7)
12	GND	33	PCLK(PA6)
13	I2C1_SCL(PB6)	34	Test point4
14	I2C1_SDA(PB9)	35	Test point7
15	Camera_PLUG(GPIO3)	36	Test point6
16	GND	37	GND
17	RST IN(GPIO2)	38	GND
18	Test point 3	39	+2.8V
19	XSDN(GPIO0)	40	+2.8V
20	Camera clock	41	GND
21	GND	42	GND

Note: GPIOx are I/O expander (U16) signals.

3.6 Daughterboard extension connector CN6 and CN7

Two 60-pin male headers CN6 and CN7 can connect a daughterboard or standard wrapping board to the STM32429I-EVAL evaluation board. All GPIOs are available on them and memory connectors (CN11 & CN12).

The space between these two connectors is defined as a standard which allows common daughterboards to be developed for several evaluations boards.

The standard width between the CN6 pin1 and CN7 pin1 is 2700 mils (68.58 mm).

Each pin on CN6 and CN7 can be used by a daughterboard after it has been disconnected from the corresponding function block on the STM32429I-EVAL evaluation board. Refer to [Table 20](#) and [Table 21](#) for details.

Table 20. Daughterboard extension connector CN6

Pin	Description	Alternative function	How to disconnect with function block on STM32429I-EVAL board
1	GND	-	-
3	PH0	OSC_IN	Remove R20, Close SB5
5	RESET#	-	-
7	PF6	SAI1_SD_B	-
9	PF10	Potentiometer	Remove R28
11	PC0	ULPI_STP	-
13	PA2	MII_MDIO/ MC_EnIndex	Remove R211, R215
15	PA0	KEY_WKUP/ MII_CRS/ MC_ENA	Remove R219, R223, SB7
17	PF8	SAI1_SCK_B	-
19	GND	-	-
21	PA4	PAR_HSYNC	Disconnect CN5
23	PC2	MII_TXD2/ MC_CurrentB	Remove R228, R232
25	PC4	MII_RXD0/ MC_BUSVOLTAGE	Remove R235, R239
27	PC3	MII_TX_CLK/ MC_CurrentC	Remove R238, R242
29	PB2	BOOT1	Remove R5
31	PJ3	LCD_R4	-
33	PB10	ULPI_D3	-
35	PB14	USB_FS2_DM	Remove R302, Disconnect CN15
37	PH6	MII_RXD2	Remove R47
39	GND	-	-

Table 20. Daughterboard extension connector CN6 (continued)

Pin	Description	Alternative function	How to disconnect with function block on STM32429I-EVAL board
41	PB12	ULPI_D5/ USB_FS2_ID	Remove R108, R260, Disconnect CN15
43	PB13	ULPI_D6/ USB_FS2_VBUS	Remove R112, R264, Disconnect CN15
45	PJ9	LCD_G2	-
47	PG7	LED2	Remove R191
49	D5V	-	-
51	PG6	LED1	Remove R192
53	PJ7	LCD_G0	-
55	PJ10	LCD_G3	-
57	PJ8	LCD_G1	-
59	GND	-	-
2	PI11	ULPI_DIR	-
4	PB5	ULPI_D7	-
6	PH1	OSC_OUT	Remove C23, X2, Close SB6
8	PF7	SAI1_MCLK_B	-
10	GND	-	-
12	PF9	SAI1_FS_B	-
14	PA1	MII_RX_CLK/ MC_ENB	Remove R210, R214
16	PC1	MII_MDC/ MC_CurrentA	Remove R218, R222
18	PA3	ULPI_D0	-
20	PA6	MC_EmergencySTOP/ PAR_PCLK	Remove R16, Disconnect CN5
22	PA7	MII_RX_DV/ MC_UL	Remove R225, R227
24	PA5	ULPI_CK	Remove R126
26	PB1	ULPI_D2/ MC_WL	Remove R104, R234
28	PH4	ULPI_NXT	-
30	GND	-	-
32	PI14	LCD_CLK	-
34	PJ4	LCD_R5	-
36	PB11	ULPI_D4	-
38	PB15	USB_FS2_DP	Remove R300, Disconnect CN15
40	PH7	MII_RXD3	Remove R46

Table 20. Daughterboard extension connector CN6 (continued)

Pin	Description	Alternative function	How to disconnect with function block on STM32429I-EVAL board
42	PJ5	LCD_R6	-
44	PJ6	LCD_R7	-
46	PC5	MII_RXD1/ MC_HEATSINK	Remove R263, R267
48	+3V3	-	-
50	GND	-	-
52	PB0	ULPI_D1/MC_VL	Remove R102, R282
54	PJ0	LCD_R1	-
56	PJ2	LCD_R3	-
58	PJ1	LCD_R2	-
60	+5V	-	-

Table 21. Daughterboard extension connector CN7

Pin	Description	Alternative function	How to disconnect with function block on STM32429I-EVAL board
1	GND	-	-
3	PC15	OSC32_OUT	Remove R18, Close SB4
5	PI15	LCD_R0	-
7	PI12	LCD_HSYNC	-
9	PI8	EXPANDER_INT	Remove R167
11	PK6	LCD_B7	-
13	PK4	LCD_B5	-
15	PG12	LED4	Remove R189
17	PG10	LED3	Remove R190
19	GND	-	-
21	PB7	PAR_VSYNC	Disconnect CN5
23	PD3	PAR_D5	Disconnect CN5
25	PG13	MII_TXD0	Remove R233
27	PJ12	LCD_B0	-
29	PG14	MII_TXD1	Remove R236
31	PB8	MII_TXD3/ MC_Dissipative Brake/ PAR_D6	Remove R240, R243, Disconnect CN5
33	PG11	MII_TX_EN/ MC_NTC	Remove R246, R249
35	PJ11	LCD_G4	-

Table 21. Daughterboard extension connector CN7 (continued)

Pin	Description	Alternative function	How to disconnect with function block on STM32429I-EVAL board
37	PK0	LCD_G5	-
39	GND	-	-
41	PA11	CAN1_RX/ USB_FS1_DM/ MC_PFCpwm	Remove R255, R298, Keep JP16 on open
43	PA9	RS232_IRDA_TX/ USB_FS1_VBUS	Remove R262, R266
45	PB3	JTDO- SWO/ I2S3_CK	Keep JP4 on open
47	PD6	NWAIT/ I2S3_SD/ PAR_D10	Keep JP5 on open, Disconnect CN5
49	D5V	-	-
51	PC8	SDCARD_D0/ MC_WH/ PAR_D2	Remove R280, R281, Disconnect CN5
53	PC11	SDCARD_D3/ SPI3_MISO/ PAR_D4	Remove R284, Disconnect CN2, CN3, CN5
55	PC10	SDCARD_D2/ SPI3_SCK/ PAR_D8	Remove R293, Disconnect CN2, CN3, CN5
57	PD2	SDCARD_CMD/ PAR_D11	Remove R294, Disconnect CN5
59	GND	-	-
2	PI13	LCD_B1	-
4	PC14	OSC32_IN	Remove R19, Close SB3
6	PC13	TAMPER_KEY	Remove R202
8	PK7	LCD_ENB	Remove R183
10	GND	-	-
12	PK5	LCD_B6	-
14	PB9	I2C1_SDA	Remove R3, R7, R171
16	PK3	LCD_B4	-
18	PB6	I2C1_SCL	Remove R4, R6, R173
20	PJ14	LCD_B2	-
22	PJ15	LCD_B3	-
24	PB4	JTRST	Remove R127
26	PJ13	LCD_B1	-

Table 21. Daughterboard extension connector CN7 (continued)

Pin	Description	Alternative function	How to disconnect with function block on STM32429I-EVAL board
28	PC12	SDCARD_CK/ SPI3_MOSI/ PAR_D9	Disconnect CN2, CN3, CN5, CN17
30	GND	-	-
32	PA15	JTDI	Remove R106
34	PK1	LCD_G6	-
36	PA14	JTCK-SWCLK	Remove R99
38	PK2	LCD_G7	-
40	PA13	JTMS-SWDIO	Remove R90
42	PA12	CAN1_TX/ USB_FS1_DP	Remove R252, R256, R261
44	PA10	RS232_IRDA_RX/ USB_FS1_ID	Remove R117, Keep JP7 on open
46	PC9	SDCARD_D1/ PAR_D3	Remove R265, Disconnect CN5
48	+3.3V	-	-
50	GND	-	-
52	PA8	LCD_BL_CTRL/ MII_MCO/ MC_PFCsync1	Remove R268, R279, R283
54	VBUS_FS1	-	-
56	PC7	MC_VH/PAR_D1/ MIC_CK	Disconnect CN1, CN5, Remove R45
58	PC6	MC_UH/PAR_D0/ I2S3_CK	Remove R292, Disconnect CN5, Keep JP4 on open
60	+5V	-	-

3.7 RS-232 connector CN8

Figure 12. RS-232 connector (front view)

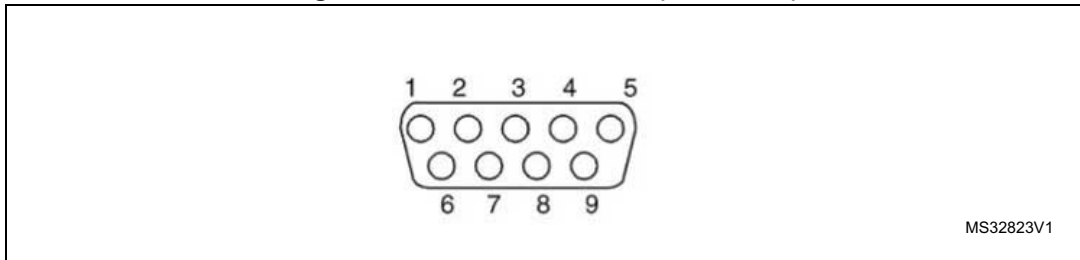

Table 22. RS-232 connector CN8 with ISP support

Pin number	Description	Pin number	Description
1	NC	6	NC
2	RS232_RX (PA10)	7	NC
3	RS232_TX (PA9)	8	NC
4	NC	9	NC
5	GND	-	-

3.8 USB OTG2 HS Micro-AB connector CN9

Figure 13. USB OTG2 HS Micro-AB connector CN9 (front view)

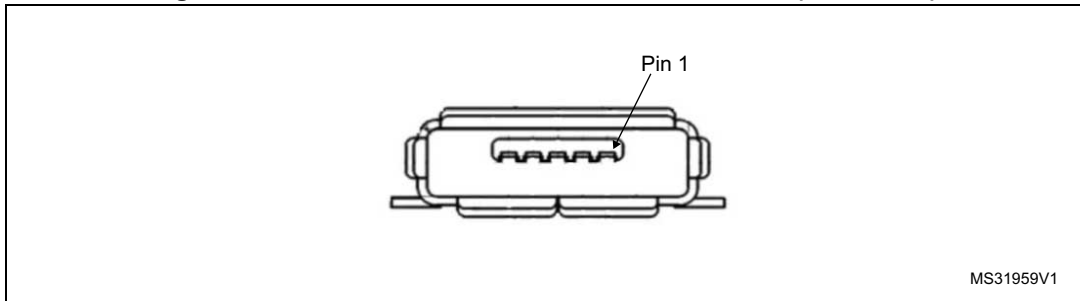

Table 23. USB OTG HS Micro-AB connector CN9

Pin number	Description	Pin number	Description
1	VBUS	4	ID
2	D-	5	GND
3	D+	-	-

3.9 Ethernet RJ45 connector CN10

Figure 14. Ethernet RJ45 connector CN10 (front view)

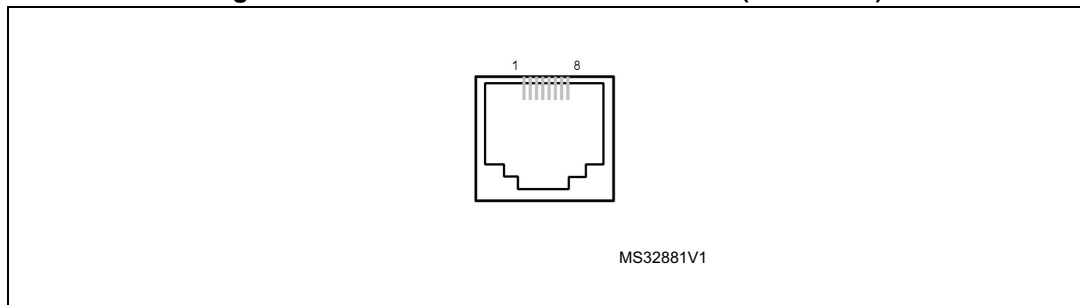

Table 24. RJ45 connector CN10

Pin number	Description	Pin number	Description
1	TxData+	2	TxData-
3	RxData+	4	Shield
5	Shield	6	RxData-
7	Shield	8	Shield

3.10 Memory connectors CN11 and CN12

Two 40-pin male headers CN11 and CN12 can connect to a memory daughterboard. GPIOs (which work as FMC memory signals) not present on CN6 and CN7 are available on these two connectors. The space between these two connectors is defined as a standard which allows common daughterboards to be developed.

The standard width between the CN11 pin1 and CN12 pin1 is 1914 mils (48.62 mm).

For signal assignments refer to [Table 25](#) and [Table 26](#) for detail.

Table 25. Memory connector CN11

Pin	Description	Alternative function	How to disconnect with function block on STM32429I-EVAL board
1	PH3	SDNE0/ MII_COL	Remove SB8
3	PF13	A7	-
5	PF12	A6	-
7	PG1	A11	-
9	GND	-	-
11	PE7	D4	-
13	PE10	D7	-
15	PE12	D9	-
17	PE15	D12	-

Table 25. Memory connector CN11 (continued)

Pin	Description	Alternative function	How to disconnect with function block on STM32429I-EVAL board
19	PE13	D10	-
21	PD11	A16	-
23	PD12	A17	-
25	PG5	A15/ BA1	-
27	PH11	D19	-
29	GND	-	-
31	PD13	A18	-
33	PG2	A12	-
35	PD8	D13	-
37	PD9	D14	-
39	PD14	D0	-
2	PH5	SDNWE	-
4	PF14	A8	-
6	PG0	A10	-
8	PF11	SDNRAS	-
10	GND	-	-
12	PE9	D6	-
14	PE8	D5	-
16	PE11	D8	-
18	PF15	A9	-
20	PE14	D11	-
22	PH8	D16	-
24	PH10	D18	-
26	PH9	D17	-
28	PG4	A14/ BA0	-
30	GND	-	-
32	PH12	D20	-
34	PG3	A13	-
36	PD10	D15	-
38	PD15	D1	-
40	PG8	SDCLK/ MII_PPS_OUT	-

Table 26. Memory connector CN12

Pin	Description	Alternative function	How to disconnect with function block on STM32429I-EVAL board
1	PF5	A5	-
3	PF4	A4	-
5	PF3	A3	-
7	PE6	A22/ SAI1_SD_A/ TRACED3/ PAR_D7	Remove R114, R120, R128
9	GND	-	-
11	PE4	A20/ TRACED1	Remove R33
13	PE3	A19/ TRACED0	Remove R39
15	PI5	NBL3	-
17	PI4	NBL2	-
19	PG15	SDNCAS	-
21	PI10	D31/ MII_RX_ER	Remove R43
23	PE1	NBL1	-
25	PE0	NBL0	-
27	PG9	NE2	-
29	GND	-	-
31	PD0	D2	-
33	PI2	D26	-
35	PI1	D25	-
37	PI0	D24	-
39	PH13	D21	-
2	PH2	SDCKE0	-
4	PE5	A21/ TRACED2	Remove R23
6	PD6	NWAIT / I2S3_SD	Set JP5 on pin1-2
8	PF2	A2	-
10	GND	-	-
12	PF1	A1	-
14	PF0	A0	-
16	PE2	A23/ TRACECLK	Remove R38

Table 26. Memory connector CN12 (continued)

Pin	Description	Alternative function	How to disconnect with function block on STM32429I-EVAL board
18	PI7	D29	-
20	PI9	D30	-
22	PI6	D28	-
24	PD7	NE1	-
26	PD5	NWE	-
28	PD4	NOE	-
30	GND	-	-
32	PD1	D3	-
34	PI3	D27	-
36	PH15	D23	-
38	PH14	D22	-
40	+3.3V	-	-

3.11 ETM trace debugging connector CN13

Figure 15. ETM trace debugging connector CN13 (top view)

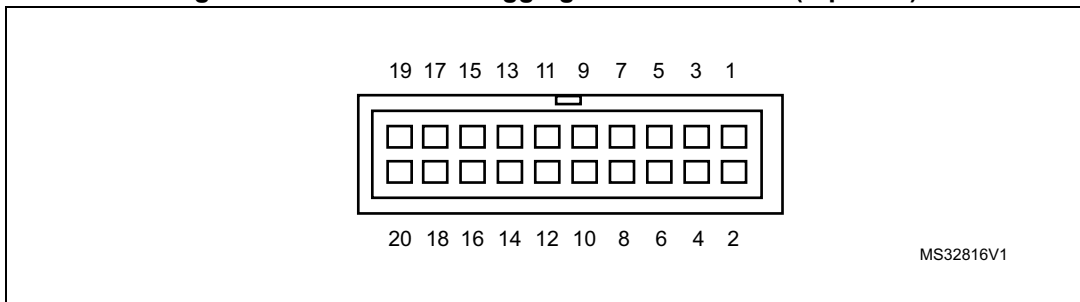

Table 27. ETM trace debugging connector CN13

Pin number	Description	Pin number	Description
1	+3.3V	2	TMS/PA13
3	GND	4	TCK/PA14
5	GND	6	TDO/PB3
7	KEY	8	TDI/PA15
9	GND	10	RESET#
11	GND	12	TraceCLK/PE2
13	GND	14	TraceD0/PE3 or SWO/PB3
15	GND	16	TraceD1/PE4 or nTRST/PB4

Table 27. ETM trace debugging connector CN13

Pin number	Description	Pin number	Description
17	GND	18	TraceD2/PE5
19	GND	20	TraceD3/PE6

3.12 USB OTG1 FS Micro-AB connector CN14

Figure 16. USB OTG1 FS Micro-AB connector CN14 (front view)

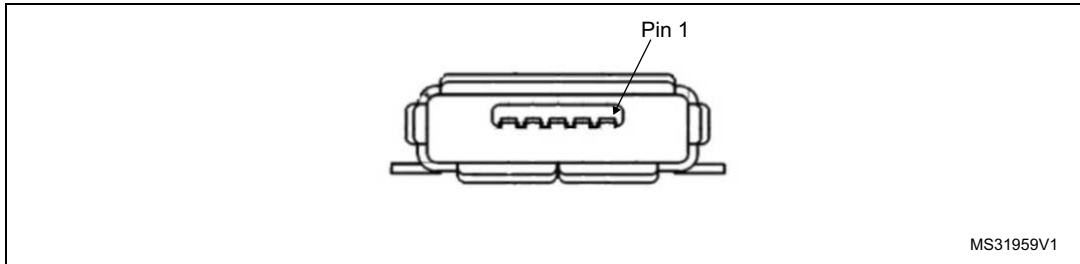

Table 28. USB OTG1 FS Micro-AB connector CN14

Pin number	Description	Pin number	Description
1	VBUS (PA9)	4	ID (PA10)
2	D- (PA11)	5	GND
3	D+ (PA12)	-	-

3.13 USB OTG2 FS Micro-AB connector CN15

Figure 17. USB OTG2 FS Micro-AB connector CN15 (front view)

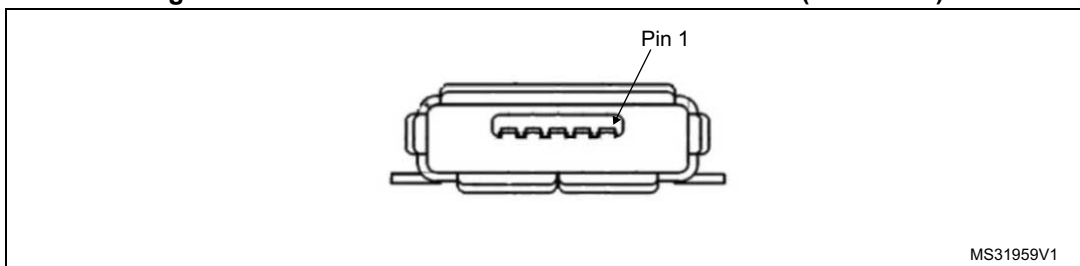

Table 29. USB OTG2 FS Micro-AB connector CN15

Pin number	Description	Pin number	Description
1	VBUS (PB13)	4	ID (PB12)
2	D- (PB14)	5	GND
3	D+ (PB15)	-	-

3.14 JTAG/SWD connector CN16

Figure 18. JTAG/SWD debugging connector CN16 (top view)

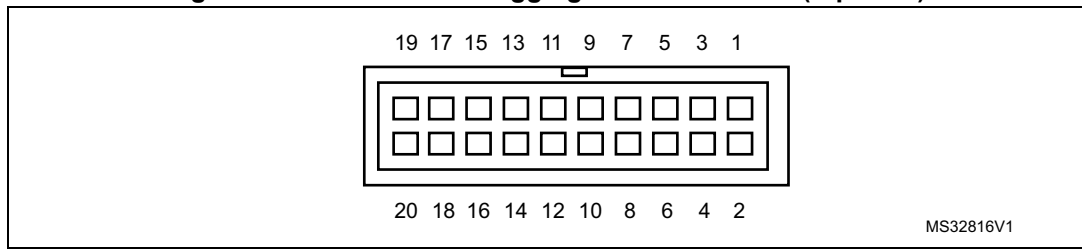

Table 30. JTAG/SWD debugging connector CN15

Pin number	Description	Pin number	Description
1	+3.3V	2	+3.3V
3	PB4	4	GND
5	PA15	6	GND
7	PA13	8	GND
9	PA14	10	GND
11	RTCK	12	GND
13	PB3	14	GND
15	RESET#	16	GND
17	DBGRRQ	18	GND
19	DBGACK	20	GND

3.15 MicroSD connector CN17

Figure 19. MicroSD connector CN17 (front view)

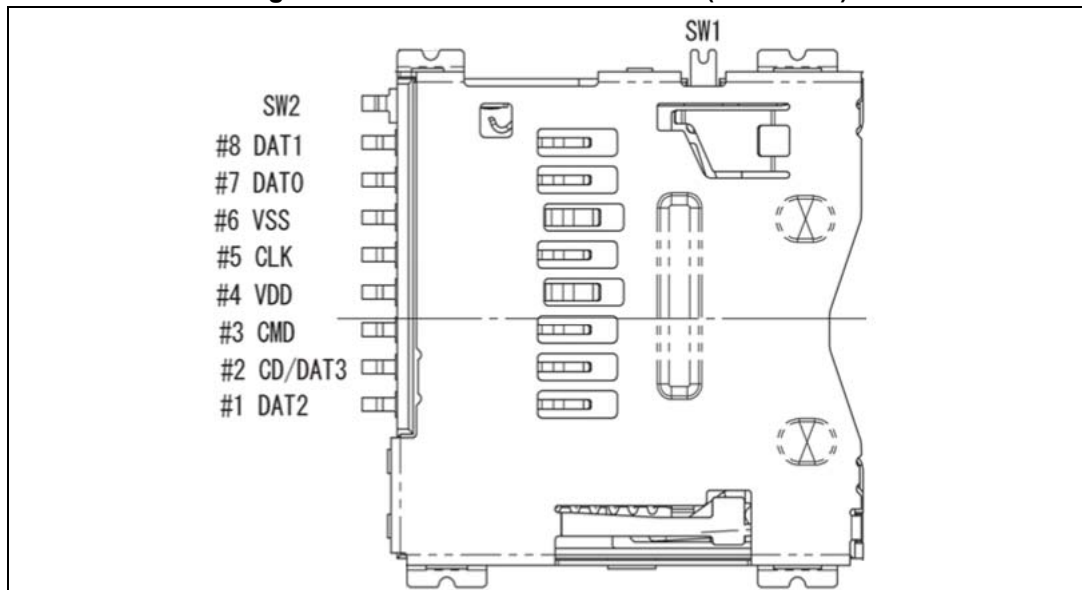

Table 31. MicroSD connector CN17

Pin number	Description	Pin number	Description
1	SDIO_D2(PC10)	6	Vss/GND
2	SDIO_D3(PC11)	7	SDIO_D0(PC8)
3	SDIO_CMD(PD2)	8	SDIO_D1(PC9)
4	+3.3V	9	GND
5	SDIO_CLK(PC12)	10	MicroSDcard_detect (GPIO15)

Note: GPIOx are I/O expander (U16) signals.

3.16 Power connector CN18

The STM32429I-EVAL evaluation board can be powered from a DC 5 V power supply via the external power supply jack (CN18) shown in [Figure 20](#). The central pin of CN18 must be positive.

Figure 20. Power supply connector CN18

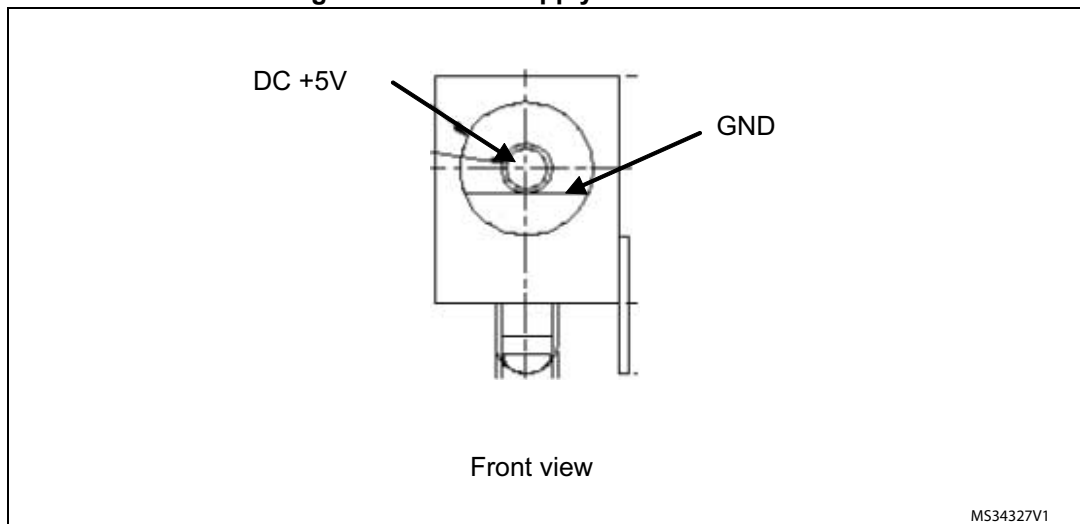

3.17 ST-LINK/V2 programming connector CN19

The connector CN19 is used only for embedded ST-LINK/V2 programming during board manufacture. It is not populated by default and not for end-user usage.

3.18 TFT LCD connector CN20

A TFT color LCD board is mounted on CN20. Refer to [Section 2.18](#) for detail.

3.19 ST-LINK/V2 USB Type B connector CN21

USB connector CN21 connects the embedded ST-LINK/V2 to PC for board debugging.

Figure 21. USB type B connector CN21 (front view)

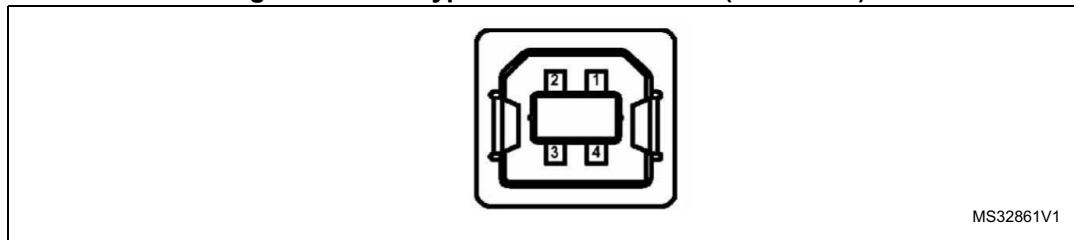

MS32861V1

Table 32. USB type B connector CN21

Pin number	Description	Pin number	Description
1	VBUS (power)	4	GND
2	DM	5,6	Shield
3	DP	-	-

3.20 CAN D-type 9-pin male connector CN22

Figure 22. CAN D-type 9-pin male connector CN22 (front view)

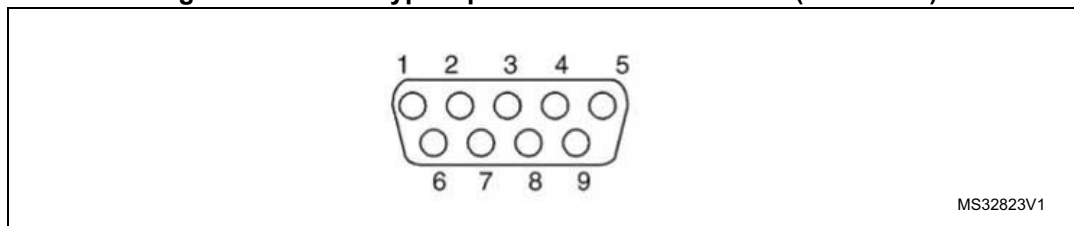

MS32823V1

Table 33. CAN D-type 9-pin male connector CN22

Pin number	Description	Pin number	Description
1,4,8,9	NC	7	CANH
2	CANL	3,5,6	GND

3.21 Audio jack CN23

A 3.5 mm stereo audio jack CN23 is available on the STM32429I-EVAL evaluation board to support a headset (headphone & microphone integrated).

3.22 Audio terminal CN24

Figure 23. Audio terminal CN24 (front view)

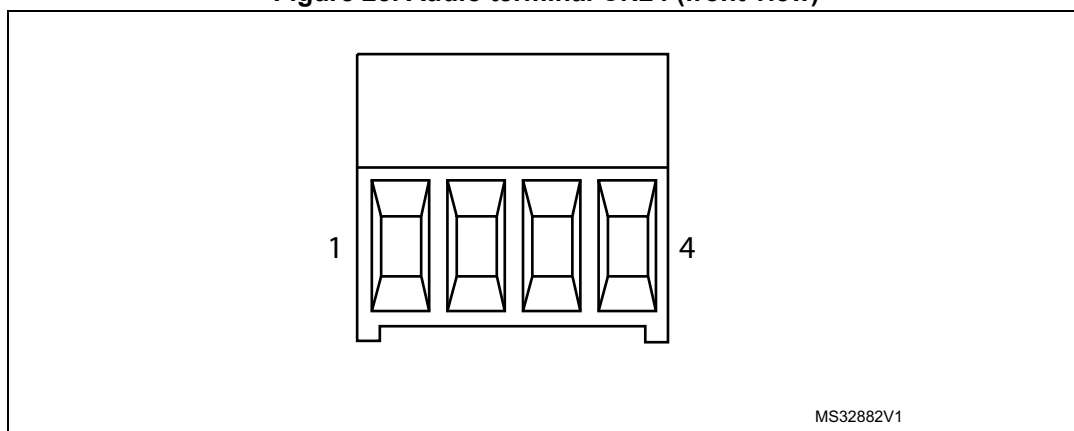

Table 34. Audio terminal CN24

Pin number	Description	Pin number	Description
1	SPKOUT_L_N	3	SPKOUT_R_N
2	SPKOUT_L_P	4	SPKOUT_R_P

3.23 ST-LINK/V2 programming Tag-connector CN25

The connector CN25 is used only by the embedded ST-LINK/V2 programming during board manufacture with Tag-connector (TC2050-IDC).

Figure 25. MCU

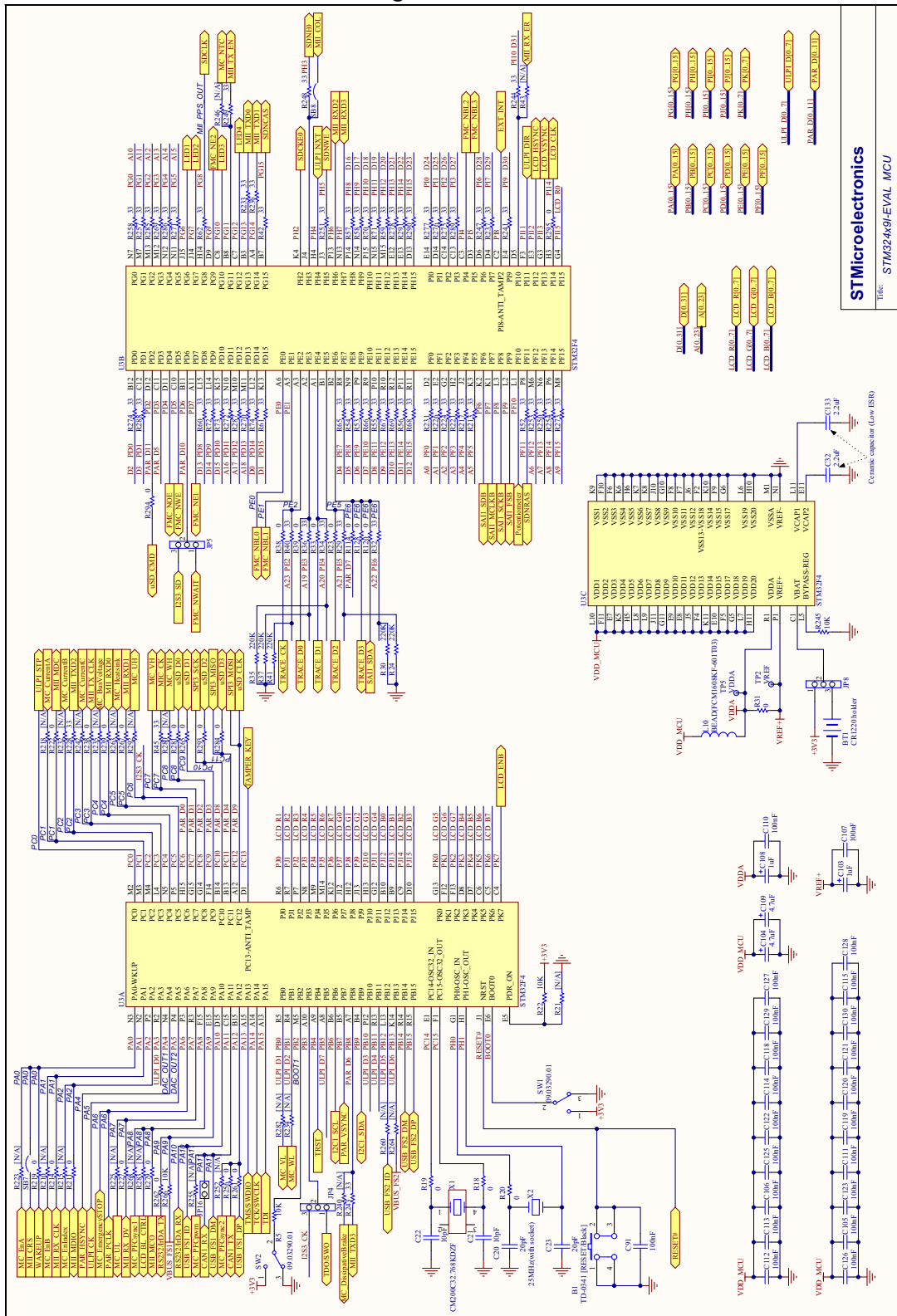

STMicroelectronics
Title: STM32469I-EVAL MCU



Figure 26. Power

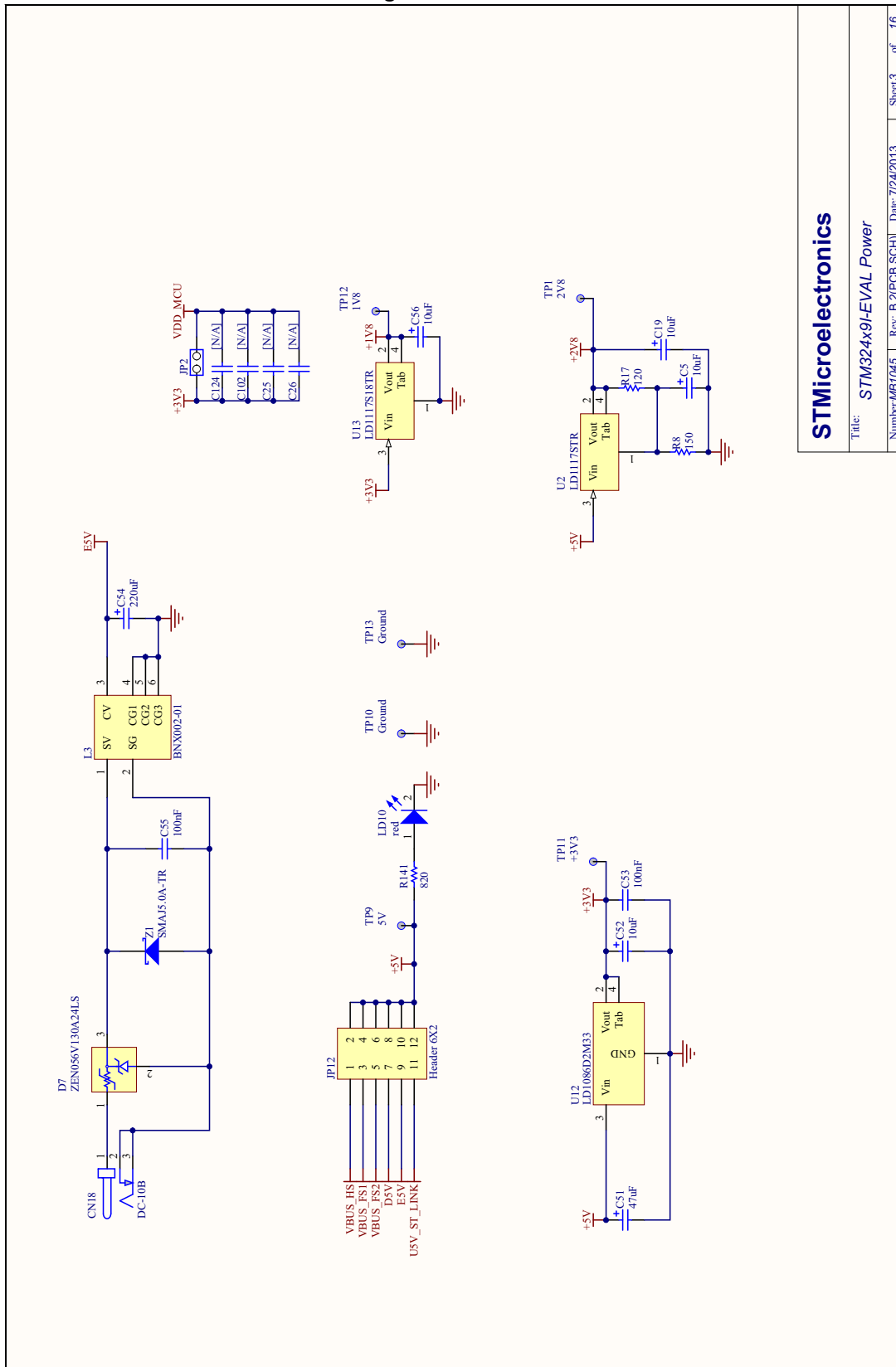

STMicroelectronics

Title: STM324x9I-EVAL Power

Number: MB1045 Rev. B.2 (PCB.SCH) Date: 7/24/2013 Sheet 3 of 16

Figure 27. SRAM, Flash and SDRAM

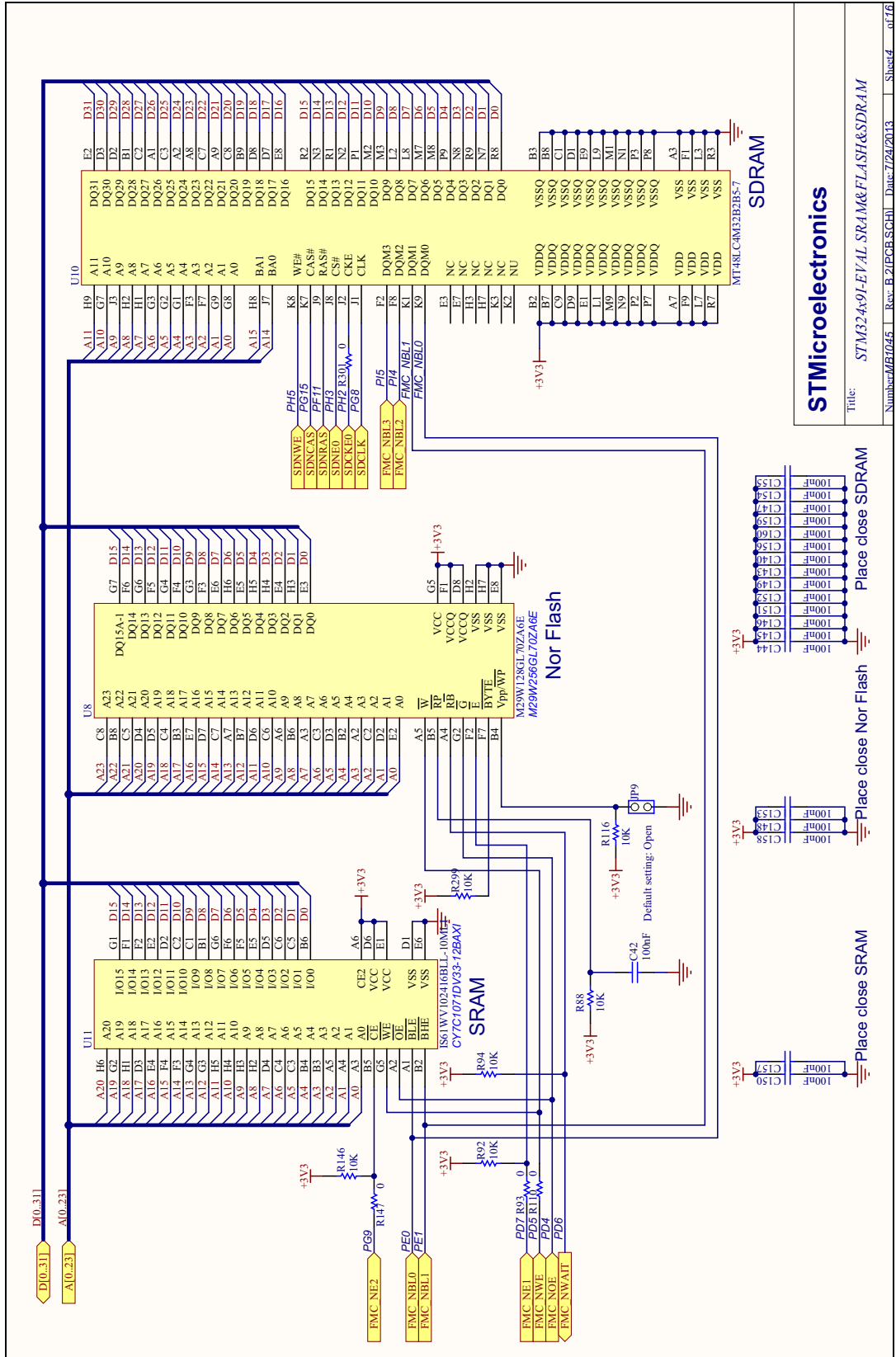

STMicroelectronics
Title: STM3249-EVAL SRAM&FLASH&SDRAM
Number: M1045 Rev: B-2/PCB.SCH1 Date: 7/24/2013 Sheet4 of 16



Figure 29. LCD, camera and connectors

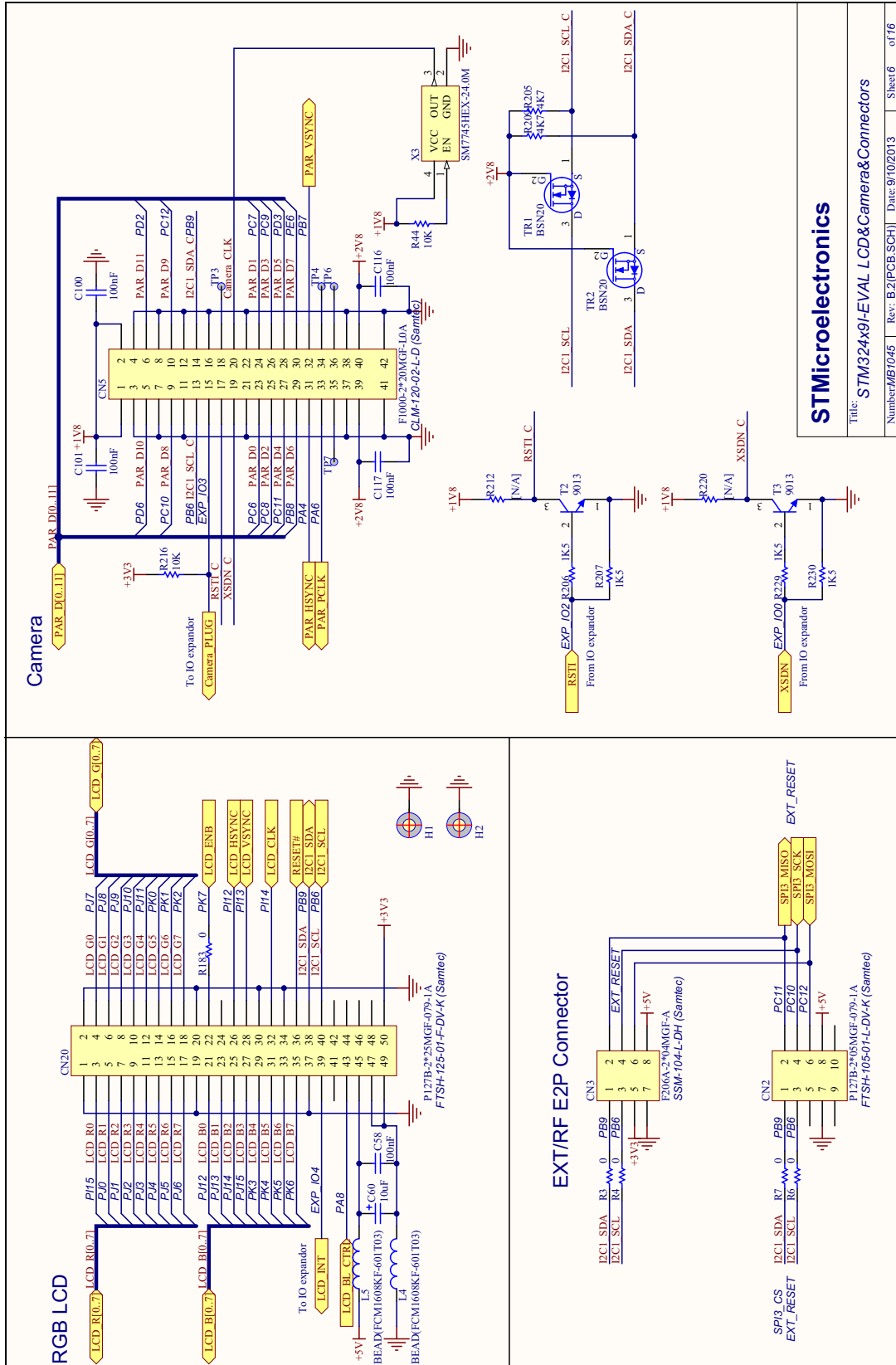
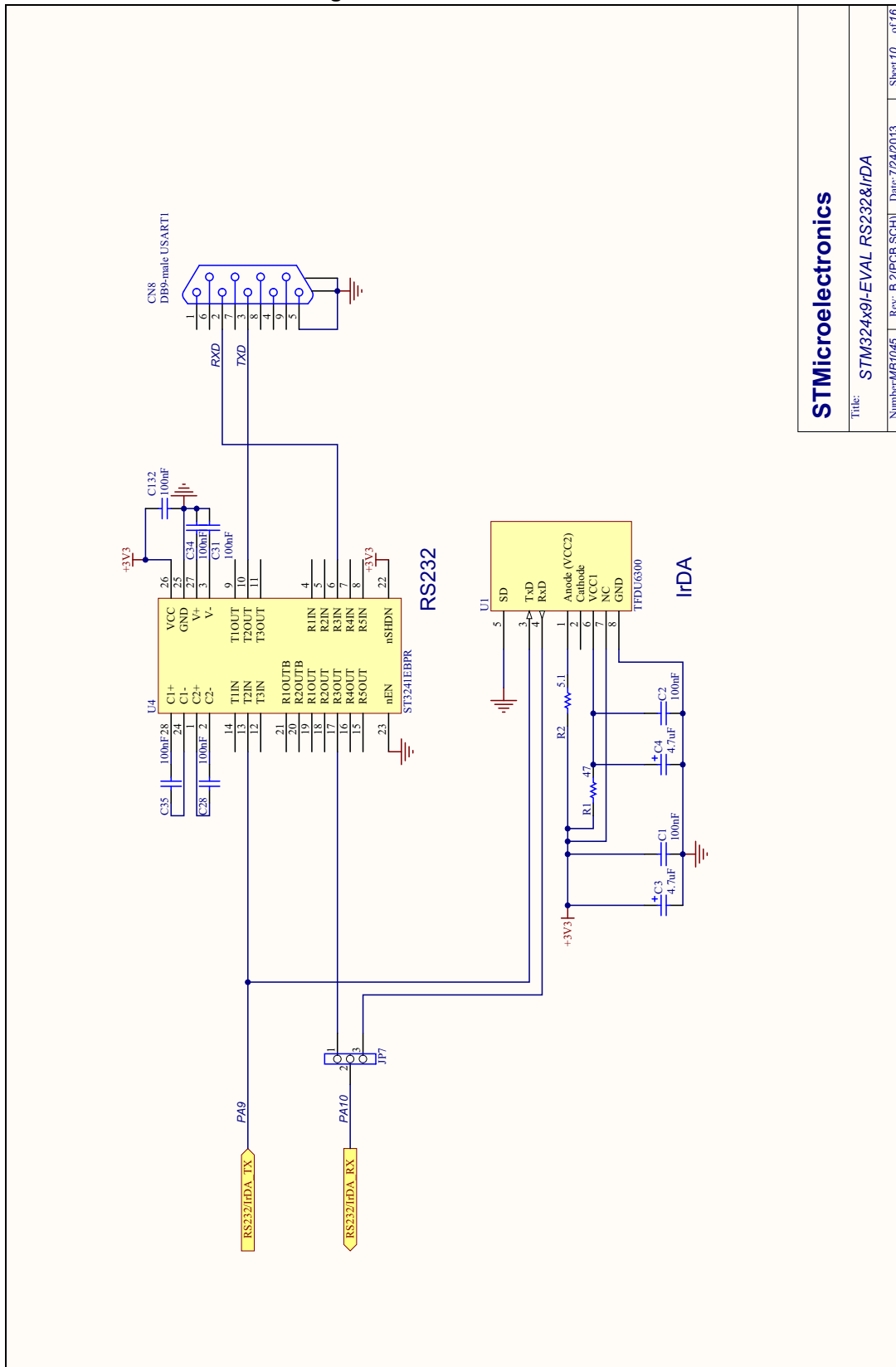

Figure 33. RS-232 and IrDA



STMicroelectronics

Title: STM324x91-EVAL RS232&IrDA

Number: MB1045 Rev. B: 2/PCB SCH1 Date: 7/24/2013 Sheet 10 of 16



Figure 34. CAN, MicroSD Card and IO expander

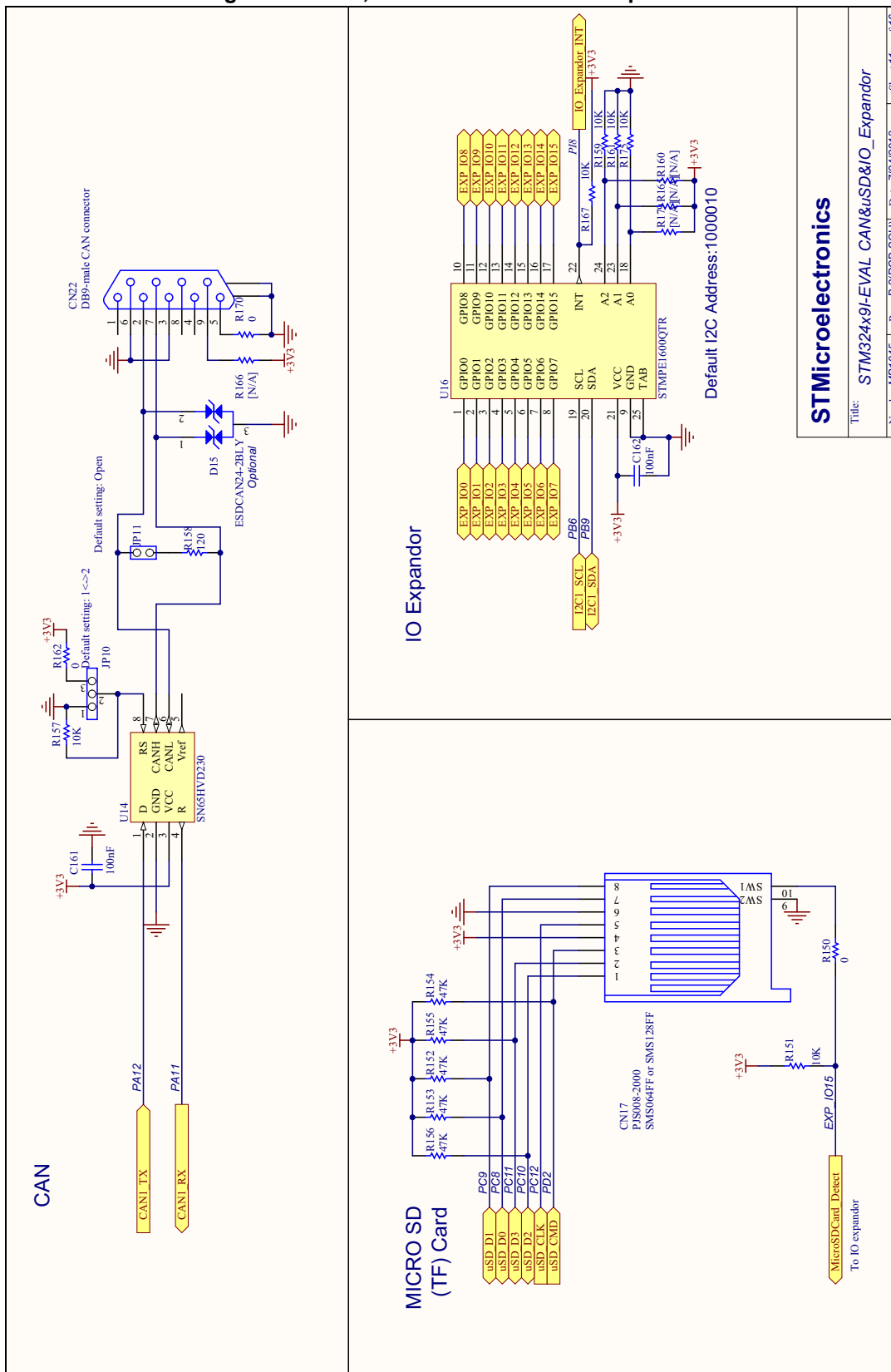
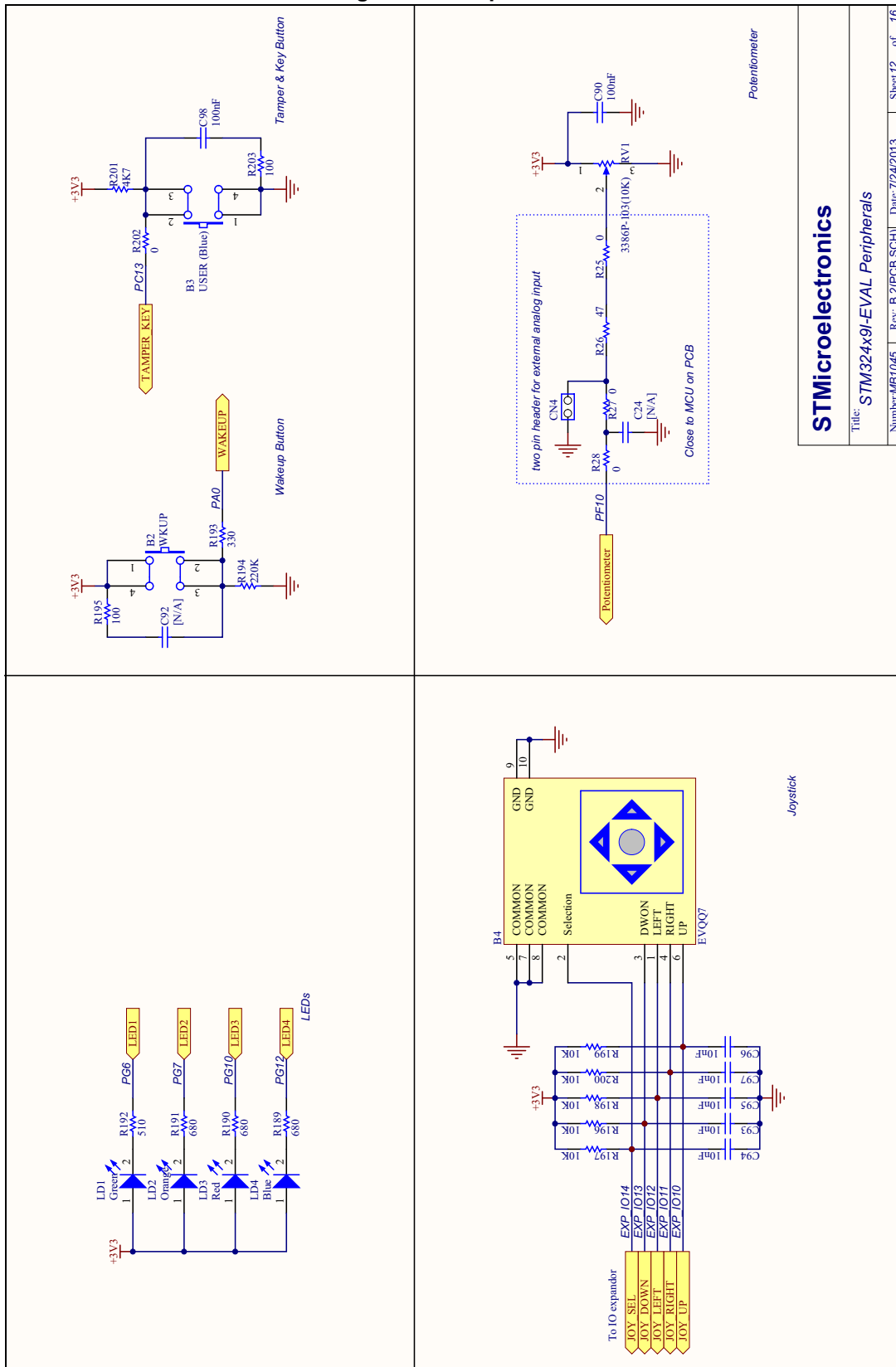

Figure 35. Peripherals



STMicroelectronics

Title: STM324x91-EVAL Peripherals

Number: MB1045 Rev. B: PCB.SCH1 Date: 7/24/2013 Sheet 12 of 16



Figure 36. Motor control

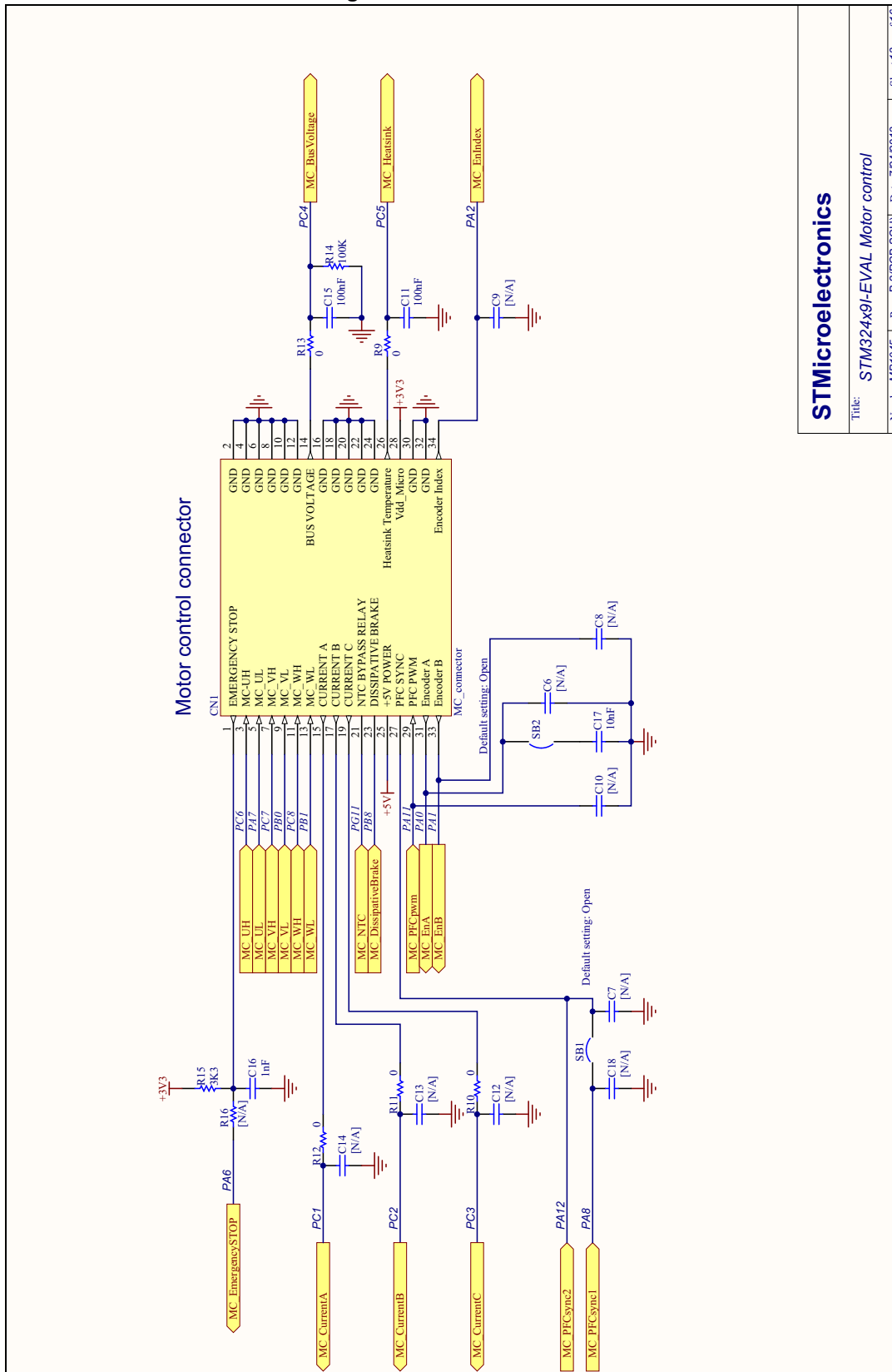

STMicroelectronics

Title: STM324x91-EVAL Motor control

Number: MB1045 Rev: B2[PCB:SCH] Date: 7/24/2013 Sheet 13 of 16

Figure 37. Extension connector

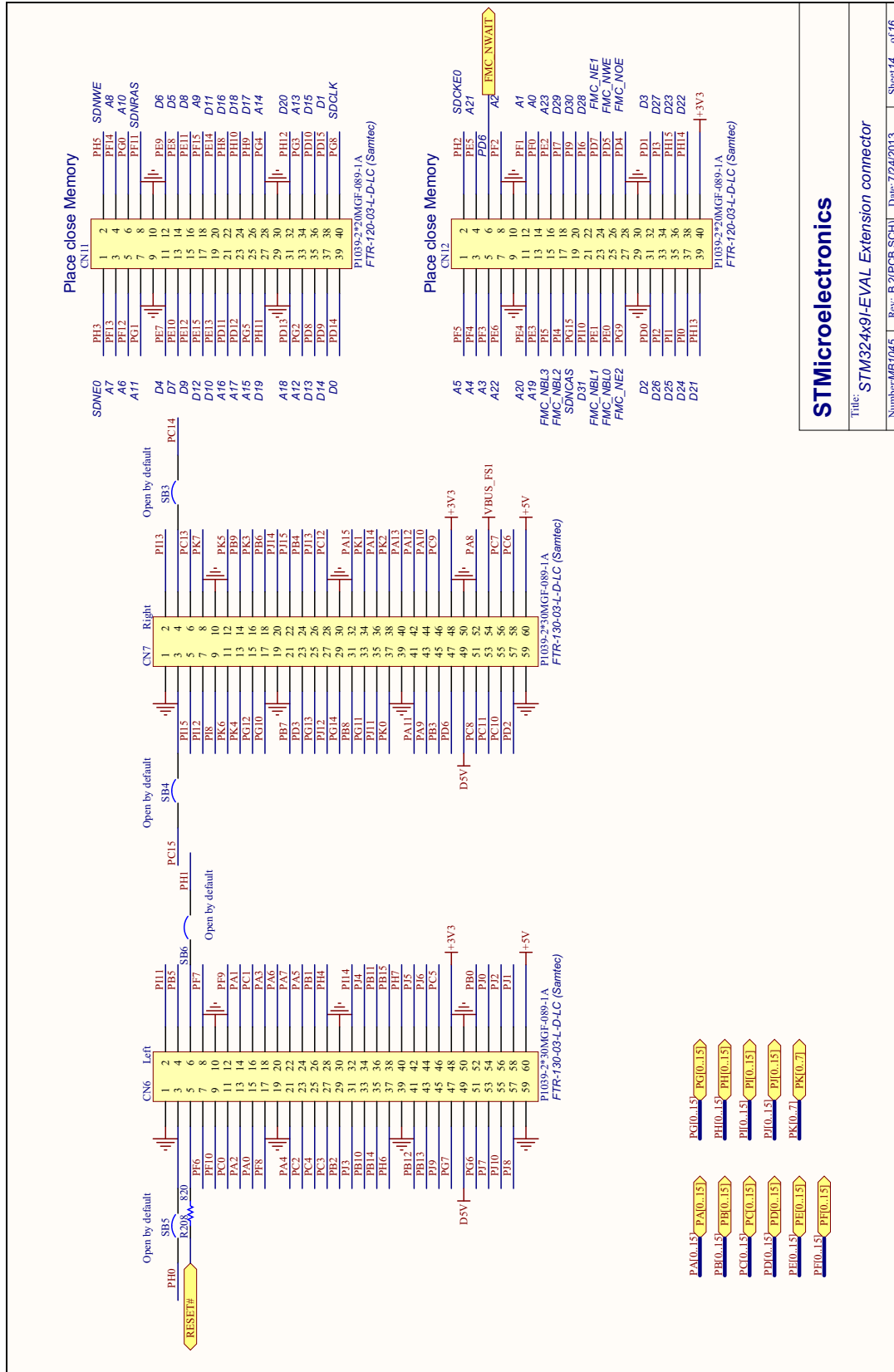

STMicroelectronics
 Title: STM324x9I-EVAL Extension connector
 Number: MB1045 Rev.: B 2(PCB_SCH) Date: 7/24/2013 Sheet 14 of 16



Figure 38. ST-LINK/V2

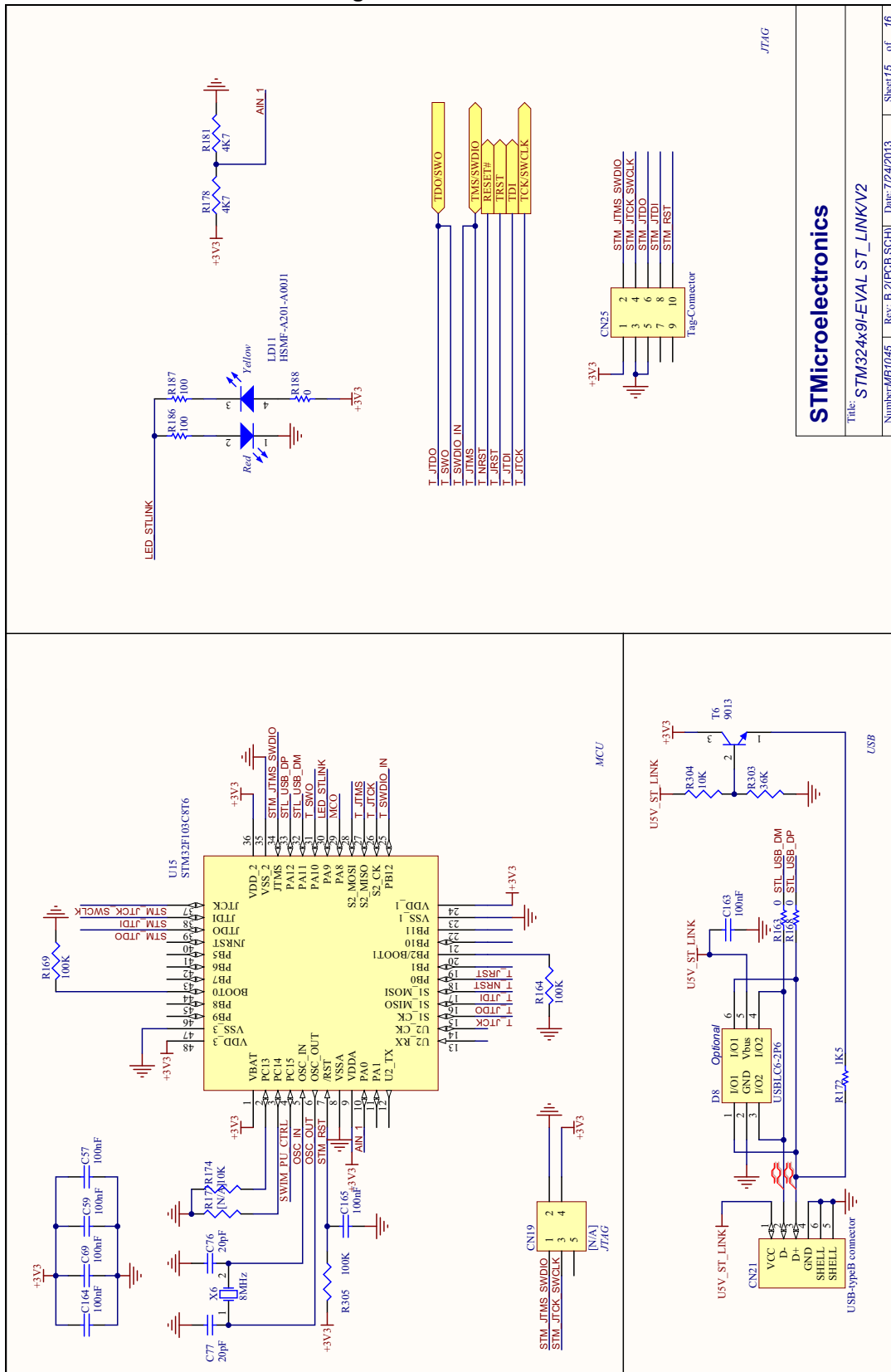

STMicroelectronics

Title: STM324x9I-EVAL_ST_LINKV2

Number: MB1045 Rev: B.2(PCB.SCH) Date: 7/24/2013 Sheet 15 of 16

Figure 39. JTAG and trace

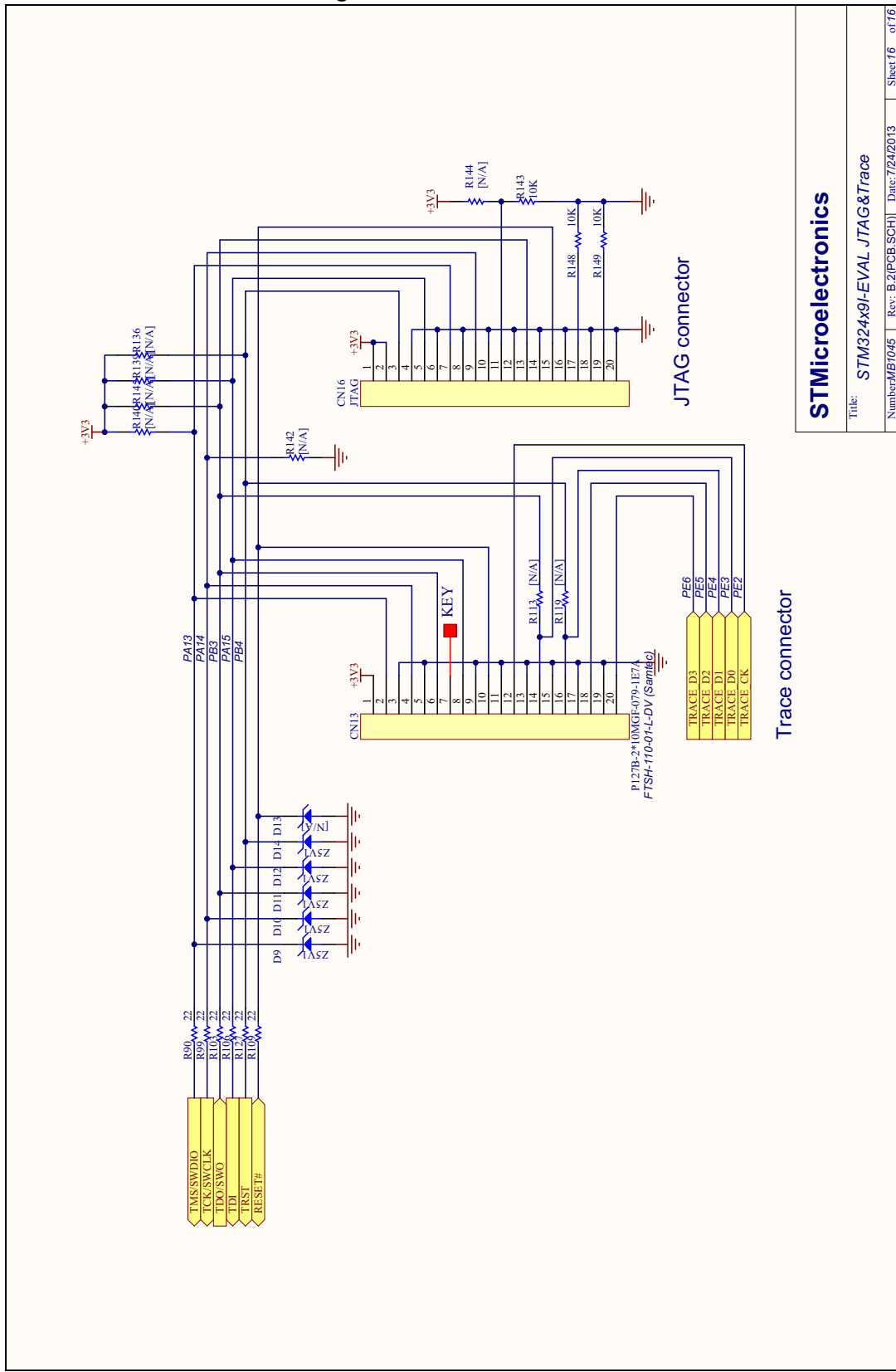

STMicroelectronics

Title: STM324x9I-EVAL JTAG&Trace

Number: MB7045 Rev: B2[PCB_SCH] Date: 7/24/2013 Sheet 16 of 16



Figure 40. 4.3' TFT LCD daughter board MB1046

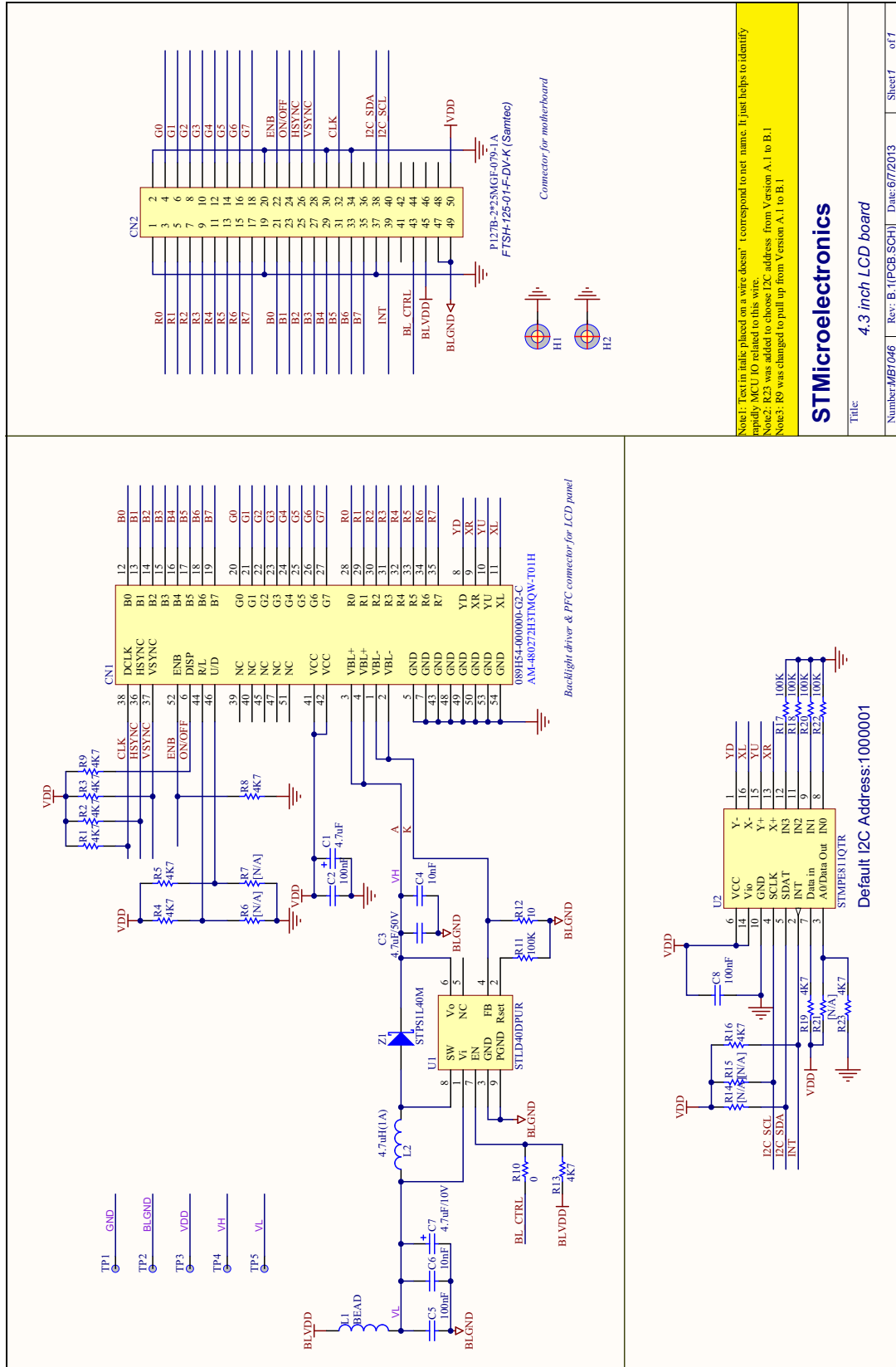

Appendix A STM32429I-EVAL I/O assignment

Table 35. STM32429I-EVAL I/O assignment

Pin number	Pin name	STM32429I-EVAL standard	Motor control variant	Camera variant
A1	PE4	A20/ TRACED1	-	-
A2	PE3	A19/ TRACED0	-	-
A3	PE2	TRACECLK	-	-
A4	PG14	MII_TXD1	-	-
A5	PE1	NBL1	-	-
A6	PE0	NBL0	-	-
A7	PB8	MII_TXD3	DISSIPATIVE_BRAKE	D6
A8	PB5	ULPI_D7	-	-
A9	PB4	JTRST	-	-
A10	PB3	JTDO-SWO/ I2S3_CK	-	-
A11	PD7	NE1	-	-
A12	PC12	SDCARD_CK/ SPI3_MOSI	-	D9
A13	PA15	JTDI	-	-
A14	PA14	JTCK-SWCLK	-	-
A15	PA13	JTMS-SWDIO	-	-
B1	PE5	A21/ TRACED2	-	-
B2	PE6	A22/ SAI1_SD_A/ TRACED3	-	D7
B3	PG13	MII_TXD0	-	-
B4	PB9	I2C1_SDA	-	-
B5	PB7		-	VSYNC
B6	PB6	I2C1_SCL	-	-
B7	PG15	SDNCAS	-	-
B8	PG11	MII_TX_EN	NTC_BYPASS_IO	-
B9	PJ13	LCD_B1	-	-
B10	PJ12	LCD_B0	-	-
B11	PD6	NWAIT/ I2S3_SD	-	D10

Table 35. STM32429I-EVAL I/O assignment (continued)

Pin number	Pin name	STM32429I-EVAL standard	Motor control variant	Camera variant
B12	PD0	D2	-	-
B13	PC11	SDCARD_D3/ SPI3_MISO	-	D4
B14	PC10	SDCARD_D2/ SPI3_SCK	-	D8
B15	PA12	CAN1_TX/ USB_FS1_DP	PFC_SYNC2	-
C1	VBAT	VBAT	-	-
C2	PI8- ANTI TAMP2	EXPANDER_INT	-	-
C3	PI4	NBL2	-	-
C4	PK7	LCD_DE	-	-
C5	PK6	LCD_B7	-	-
C6	PK5	LCD_B6	-	-
C7	PG12	LED4	-	-
C8	PG10	LED3	-	-
C9	PJ14	LCD_B2	-	-
C10	PD5NWE	-	-	-
C11	PD3	-	-	D5
C12	PD1	D3	-	-
C13	PI3	D27	-	-
C14	PI2	D26	-	-
C15	PA11	CAN1_RX/ USB_FS1_DM	PFC_PWM	
D1	PC13	KEY_TAMP_1	-	-
D2	PF0	A0	-	-
D3	PI5	NBL3	-	-
D4	PI7	D29	-	-
D5	PI10	D31/ MII_RX_ER	-	-
D6	PI6	D28	-	-
D7	PK4	LCD_B5	-	-
D8	PK3	LCD_B4	-	-
D9	PG9	NE2	-	-
D10	PJ15	LCD_B3	-	-
D11	PD4	NOE	-	-

Table 35. STM32429I-EVAL I/O assignment (continued)

Pin number	Pin name	STM32429I-EVAL standard	Motor control variant	Camera variant
D12	PD2	SDCARD_CMD	-	D11
D13	PH15	D23	-	-
D14	PI1	D25	-	-
D15	PA10	RS232_IRDA_RX/ USB_FS1_VBUS/ USB_FS1_ID	-	-
E1	PC14	OSC32_IN	-	-
E2	PF1	A1	-	-
E3	PI12	LCD_HSYNC	-	-
E4	PI9	D30	-	-
E5	PDR_ON	-	-	-
E6	BOOT0	BOOT0	-	-
E7	VDD_3	-	-	-
E8	VDD_11	-	-	-
E9	VDD_10	-	-	-
E10	VDD_15	-	-	-
E11	VCAP2	-	-	-
E12	PH13	D21	-	-
E13	PH14	D22	-	-
E14	PI0	D24	-	-
E15	PA9	RS232/ IRDA_USART1_TX/ USB_FS1_VBUS	-	-
F1	PC15	OSC32_OUT	-	-
F2	VSS_13_18	-	-	-
F3	PI11	ULPI_DIR		
F4	VDD_13	-	-	-
F5	VDD_17	-	-	-
F6	VSS_3	-	-	-
F7	VSS_11	-	-	-
F8	VSS_10	-	-	-
F9	VSS_15	-	-	-
F10	VSS_2	-	-	-
F11	VDD_2	-	-	-
F12	PK1	LCD_G6	-	-

Table 35. STM32429I-EVAL I/O assignment (continued)

Pin number	Pin name	STM32429I-EVAL standard	Motor control variant	Camera variant
F13	PK2	LCD_G7	-	-
F14	PC9	SDCARD_D1	-	D3
F15	PA8	LCD_BL_CTRL	PFC_SYNC1	-
G1	PH0	OSC_IN	-	-
G2	PF2	A2	-	-
G3	PI13	LCD_VSYNC	-	-
G4	PI15	LCD_R0	-	-
G5	VDD_18	-	-	-
G6	VSS_17	-	-	-
G10	VSS_9	-	-	-
G11	VDD_9	-	-	-
G12	PJ11	LCD_G4	-	-
G13	PK0	LCD_G5	-	-
G14	PC8	SDCARD_D0	WH	D2
G15	PC7	-	VH	D1
H1	PH1	OSC_OUT	-	-
H2	PF3	A3	-	-
H3	PI14	LCD_CLK	-	-
H4	PH4	ULPI_NXT	-	-
H5	VDD_5	-	-	-
H6	VSS_5	-	-	-
H10	VSS_20	-	-	-
H11	VDD_20	-	-	-
H12	PJ8	LCD_G1	-	-
H13	PJ10	LCD_G3	-	-
H14	PG8	SDCLK/ MII_PPS_OUT	-	-
H15	PC6	LCD_ON_OFF	UH	D0
J1	NRST	NRST	-	-
J2	PF4	A4	-	-
J3	PH5	SDNWE	-	-
J4	PH3	SDNE0/ MII_COL	-	-
J5	VDD_12	-	-	-
J6	VSS_12	-	-	-

Table 35. STM32429I-EVAL I/O assignment (continued)

Pin number	Pin name	STM32429I-EVAL standard	Motor control variant	Camera variant
J10	VSS_8	-	-	-
J11	VDD_8	-	-	-
J12	PJ7	LCD_G0	-	-
J13	PJ9	LCD_G2	-	-
J14	PG7	LED2	-	-
J15	PG6	LED1	-	-
K1	PF7	SAI1_MCLK_B	-	-
K2	PF6	SAI1_SD_B	-	-
K3	PF5	A5	-	-
K4	PH2	SDCKE0	-	-
K5	VDD_4	-	-	-
K6	VSS_4	-	-	-
K7	VSS_6	-	-	-
K8	VSS_7	-	-	-
K9	VSS_1	-	-	-
K10	VSS_14	-	-	-
K11	VDD_14	-	-	-
K12	PJ6	LCD_R7		
K13	PD15	D1	-	-
K14	PB13	ULPI_D6/ USB_FS2_VBUS	-	-
K15	PD10	D15	-	-
L1	PF10	Potentiometer	-	-
L2	PF9	SAI1_FS_B	-	-
L3	PF8	SAI1_SCK_B	-	-
L4	PC3	MII_TX_CLK	CURRENT_C	-
L5	BYPASS_REG	-	-	-
L6	VSS_19	-	-	-
L7	VDD_19	-	-	-
L8	VDD_6	-	-	-
L9	VDD_7	-	-	-
L10	VDD_1	-	-	-
L11	VCAP1	-	-	-
L12	PD14	D0	-	-

Table 35. STM32429I-EVAL I/O assignment (continued)

Pin number	Pin name	STM32429I-EVAL standard	Motor control variant	Camera variant
L13	PB12	ULPI_D5/ USB_FS2_ID	-	-
L14	PD9	D14	-	-
L15	PD8	D13	-	-
M1	VSSA	-	-	-
M2	PC0	ULPI_STP	-	-
M3	PC1	MII_MDC	-	-
M4	PC2	MII_TXD2	CURRENT_B	-
M5	PB2	BOOT1	-	-
M6	PF12	A6	-	-
M7	PG1	A11	-	-
M8	PF15	A9	-	-
M9	PJ4	LCD_R5	-	-
M10	PD12	A17	-	-
M11	PD13	A18	-	-
M12	PG3	A13	-	-
M13	PG2	A12	-	-
M14	PJ5	LCD_R6	-	-
M15	PH12	D20	-	-
N1	VREF-	-	-	-
N2	PA1	MII_RX_CLK	ENCODER_B	-
N3	PA0	KEY_WKUP/ MII_CR5	ENCODER_A	-
N4	PA4	-	DAC_OUT1	HSYNC
N5	PC4	MII_RXD0	BUSVOLTAGE	-
N6	PF13	A7	-	-
N7	PG0	A10	-	-
N8	PJ3	LCD_R4	-	-
N9	PE8	D5	-	-
N10	PD11	A16	-	-
N11	PG5	A15/ BA1	-	-
N12	PG4	A14/ BA0	-	-
N13	PH7	MII_RXD3	-	-

Table 35. STM32429I-EVAL I/O assignment (continued)

Pin number	Pin name	STM32429I-EVAL standard	Motor control variant	Camera variant
N14	PH9	D17	-	-
N15	PH11	D19	-	-
P1	VREF+	-	-	-
P2	PA2	MII_MDIO	INDEX	-
P3	PA6	-	STOP	PIXCK
P4	PA5	ULPI_CK	DAC_OUT2	-
P5	PC5	MII_RXD1	HEATSINK	-
P6	PF14	A8	-	-
P7	PJ2	LCD_R3	-	-
P8	PF11	SDNRAS	-	-
P9	PE9	D6	-	-
P10	PE11	D8	-	-
P11	PE14	D11	-	-
P12	PB10	ULPI_D3	-	-
P13	PH6	MII_RXD2	-	-
P14	PH8	D16	-	-
P15	PH10	D18	-	-
R1	VDDA	-	-	-
R2	PA3	ULPI_D0	-	-
R3	PA7	MII_RX_DV	UL	-
R4	PB1	ULPI_D2	WL	-
R5	PB0	ULPI_D1	VL	-
R6	PJ0	LCD_R1	-	-
R7	PJ1	LCD_R2	-	-
R8	PE7	D4	-	-
R9	PE10	D7	-	-
R10	PE12	D9	-	-
R11	PE15	D12	-	-
R12	PE13	D10	-	-
R13	PB11	ULPI_D4	-	-
R14	PB14	USB_FS2_DM	-	-
R15	PB15	USB_FS2_DP	-	-

Appendix B Mechanical dimensions

Figure 42. Mechanical dimensions

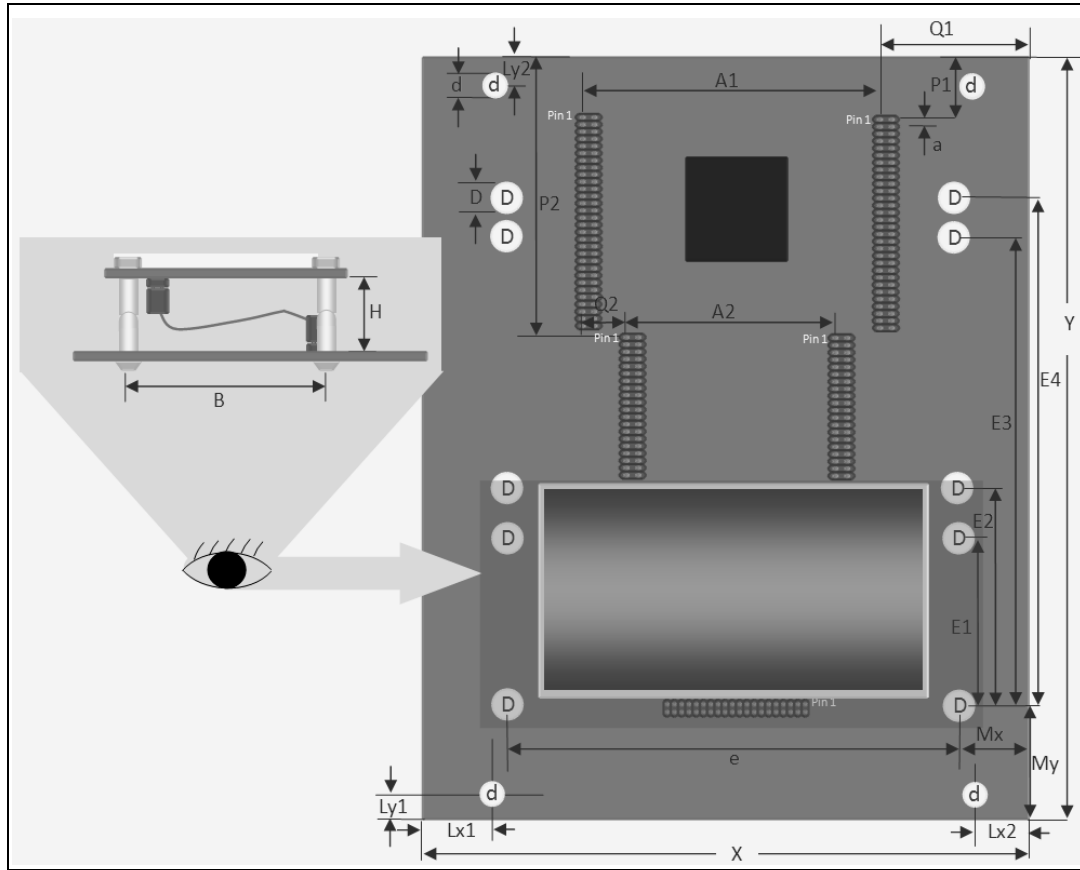

Table 36. Mechanical dimensions

Symbol	Size (mm)	Symbol	Size (mm)	Symbol	Size (mm)
A1	68.58	E3	114.18	Mx	20.1
A2	48.62	E4	122	My	24.43
a	1.27	e	116.5	P1	16.94
D	4.5	H	25	P2	55.37
d	3.5	Lx1	21.36	Q1	46.77
E1	55	Lx2	32.64	Q2	9.98
E2	68	Ly1	5	X	157
		Ly2	6.4	Y	172.72

Revision history

Table 37. Document revision history

Date	Revision	Changes
12-Sept-2013	1	Initial release
06-Mar-2015	2	Updated document title, Table 7: USB OTG2 configuration , Figure 24: STM32429I-EVAL

IMPORTANT NOTICE – PLEASE READ CAREFULLY

STMicroelectronics NV and its subsidiaries ("ST") reserve the right to make changes, corrections, enhancements, modifications, and improvements to ST products and/or to this document at any time without notice. Purchasers should obtain the latest relevant information on ST products before placing orders. ST products are sold pursuant to ST's terms and conditions of sale in place at the time of order acknowledgement.

Purchasers are solely responsible for the choice, selection, and use of ST products and ST assumes no liability for application assistance or the design of Purchasers' products.

No license, express or implied, to any intellectual property right is granted by ST herein.

Resale of ST products with provisions different from the information set forth herein shall void any warranty granted by ST for such product.

ST and the ST logo are trademarks of ST. All other product or service names are the property of their respective owners.

Information in this document supersedes and replaces information previously supplied in any prior versions of this document.

© 2015 STMicroelectronics – All rights reserved

X-ON Electronics

Largest Supplier of Electrical and Electronic Components

Click to view similar products for [Development Boards & Kits - ARM category](#):

Click to view products by [STMicroelectronics manufacturer](#):

Other Similar products are found below :

[CWH-CTP-VSPA-YE](#) [CY4541](#) [EVAL-ADUCM320IQSPZ](#) [FRDM-KV31F](#) [POLYPOD-BGA324](#) [POLYPOD-TQ144](#) [POLYPOD-TQ176](#)
[KEA128LEDLIGHTRD](#) [KIT_XMC42_EE1_001](#) [SAFETI-HSK-RM48](#) [LS1024A-RDB](#) [ADM00573](#) [FRDM-KL28Z](#) [PICOHOBBITFL](#)
[MCIMX53-START-R](#) [TWR-K65F180M](#) [KEA128BLDCRD](#) [CC-ACC-MMK-2443](#) [STM8L1528-EVAL](#) [YSPKS5D9E10](#) [YGRPEACHFULL](#)
[TWR-MC-FRDMKE02Z](#) [TWR-K80F150M](#) [CY14NVSRAMKIT-001](#) [EVALSPEAR320CPU](#) [EVB-SCMIMX6SX](#) [MAXWSNENV#](#) [FM0-64L-S6E1C3](#) [MAX32600-KIT#](#) [TMDX570LS04HDK](#) [Z32F3840100KITG](#) [LS1021A-IOT-B](#) [SK-FM3-100PMC-MB9BF516N](#) [TXSD-SV70](#)
[YSTBS3A3E10](#) [YR8A77430HA02BG](#) [STM3240G-USB/NMF](#) [OM13080UL](#) [EVAL-ADUC7120QSPZ](#) [CYDP-KIT-13638](#) [OM13063UL](#)
[ATAVRPARROT](#) [OM13090UL](#) [YSPEHMI1S20](#) [TXSD-SV71](#) [YGRPEACHNORMAL](#) [SK-FM3-176PMC-ETHERNET](#) [HVP-KV11Z75M](#)
[OM13076UL](#) [LX2RDBKIT2-25G](#)