



Thyristors type T51 are of modern design with internal spring loaded contacts, high alumina ceramic insulator and pressure welding encapsulation. Designed for use in power electronic circuits and equipment under normal operating conditions.

KEY PARAMETERS

U_{DRM}, U_{RRM}	up to 1600 V
$I_{T(AV)}$	80 A
I_{TSM}	1450 A
du/dt^*	1000 V/μs
di/dt	100 A/μs

* maximum (non standard) value

FEATURES

- all diffused design
- high current capabilities
- high surge current capabilities
- high rates voltages
- high du/dt
- low gate current
- dynamic gate
- low thermal impedance
- tested according to IEC standards
- compact size and small weight

APPLICATION

- High Power Drives
- DC Motor Control
- High Voltage Power Supplies

Designed for use in high power industrial and commercial power electronic circuits and equipment where high currents are encountered and high reliability is essential.

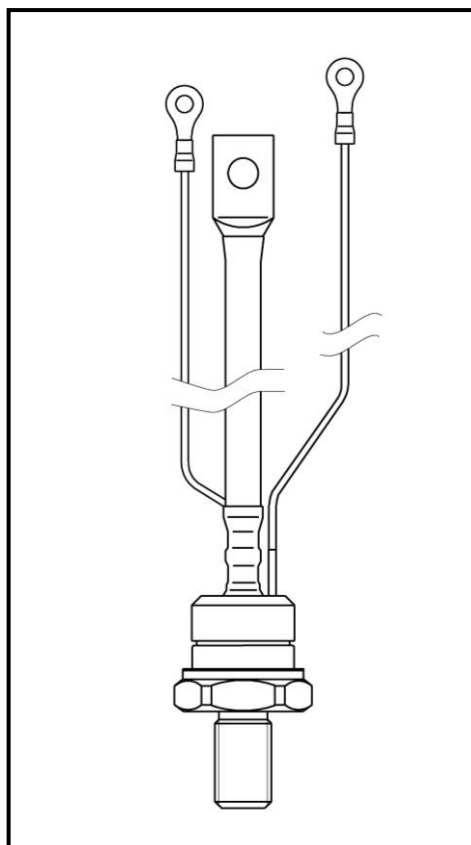

Outline type code: JEDEC TO-209AC
(TO-94)

See package details for further information

T51-80

Phase Control Thyristor



KKT5180, January 2007 version

ORDERING INFORMATION

When ordering please refer to device code builder presented below.
Please use the complete part number when ordering, quote or in any future correspondence relating to your order.

T51-80-□□

└─── voltage class (hundreds of volts)

This is standard device, with no dynamic parameters specified and standard accessory set.
Please refer to **Electrical Parameters** if specific dynamic demands have to be met.
Those information, as well as any other concerning non-standard accessories e.g. stud thread, custom leads length or lead terminal connector type should be included in the order.

ELECTRICAL PARAMETERS

Voltage ratings

Voltage class	U_{DRM}, U_{RRM}	U_{DSM}, U_{RSM}	I_{DRM}, I_{RRM}
	V	V	mA
14	1400	1500	10
16	1600	1700	

du/dt group codes

Group code	du/dt
	V/ μ s
0	no specified value
4	200
5	320
6	500
7	1000

Zakłady Elektronowe LAMINA S.A.
Puławska 34
PL-05-500 Piaseczno
POLAND

Tel.: +48-22-7572731
Tel.: +48-22-3989409
Fax.: +48-22-3989407
e-mail: sekretariat@lamina.com.pl
www.lamina.com.pl

T51-80

Phase Control Thyristor

KKT5180, January 2007 version

Electrical properties

Parameter	Unit	Test conditions	Value
Average on-state current	$I_{T(AV)}$	A	80
Case temperature	T_c	°C	90
RMS on-state current	$I_{T(RMS)}$	A	125
Surge current	I_{TSM}	A	$T_j=125^\circ\text{C}$, $U_R=0,8U_{RRM}$, $t_p=10\text{ms}$
I^2t – value	I^2t	kA^2s	10,5
On-state voltage max.	U_{TM}	V	$T_j=25^\circ\text{C}$, $I_{TM}=500\text{A}$
Threshold voltage	$U_{T(T0)}$	V	0,93
Slope resistance	r_T	$\text{m}\Omega$	3,20
Latching current	I_l	mA	$T_j=25^\circ\text{C}$, $U_D=12\text{V}$
Holding current	I_H	mA	$T_j=25^\circ\text{C}$, $U_D=12\text{V}$
Circuit commutated turn-off time (typical)	t_q	μs	$T_j=125^\circ\text{C}$, $I_{TM}=50\text{A}$, $di_R/dt=5\text{A}/\mu\text{s}$, $du/dt=20\text{V}/\mu\text{s}$, $U_D=0,67U_{DRM}$, $U_{RM}=100\text{V}$
Turn-On time (typical)	t_{on}	μs	$I_{TM}=100\text{A}$, $U_{DM}=100\text{V}$
Rate of rise of on-state current-repetitive	di/dt	$\text{A}/\mu\text{s}$	$T_j=125^\circ\text{C}$, $I_{TM}=3I_{T(AV)}$, $U_D=0,67U_{DRM}$, $f=50\text{Hz}$, $I_{GM}=1\text{A}$, $di_G/dt=1\text{A}/\mu\text{s}$
Critical rate of raise of off-state voltage	du/dt	$\text{V}/\mu\text{s}$	$T_j=125^\circ\text{C}$, $U_D=0,67U_{DRM}$, 200 - 1000
Gate current to trigger	I_{GT}	mA	$T_j=25^\circ\text{C}$, $U_D=12\text{V}$
Gate voltage to trigger	U_{GT}	V	$T_j=25^\circ\text{C}$, $U_D=12\text{V}$

Thermal properties

Parameter	Unit	Test conditions	Value
Thermal resistance, junction to case	R_{thJC}	°C/W	DC
Thermal resistance, case to heatsink	R_{thCS}	°C/W	0,25
Operating junction temperature	$T_{jmin} \dots T_{jmax}$	°C	0,12
Storage temperature	T_{stg}	°C	-40...+125

Mechanical properties

Parameter	Unit	Value
Mounting torque	M	Nm
Weight	m	g

T51-80

Phase Control Thyristor

KKT5180, January 2007 version

Package details

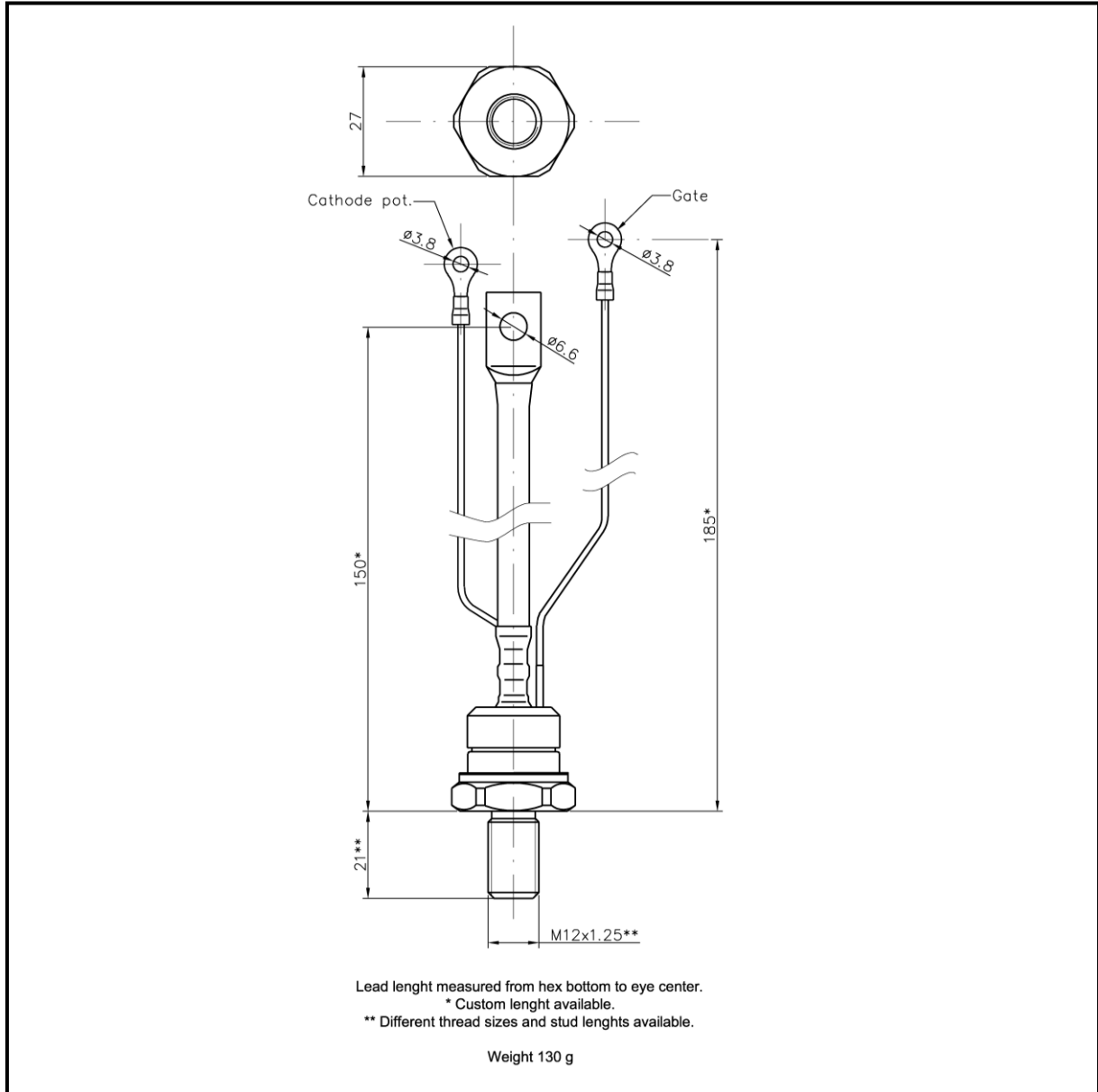

For further package information, please contact Sales & Marketing Department. All dimensions in mm, unless stated otherwise.
Do not scale.

Zakłady Elektronowe LAMINA S.A.
Puławska 34
PL-05-500 Piaseczno
POLAND

Tel.: +48-22-7572731
Tel.: +48-22-3989409
Fax.: +48-22-3989407
e-mail: sekretariat@lamina.com.pl
www.lamina.com.pl

T51-80

Phase Control Thyristor



Zakłady Elektronowe
LAMINA S.A.

KKT5180, January 2007 version

CHARACTERISTICS

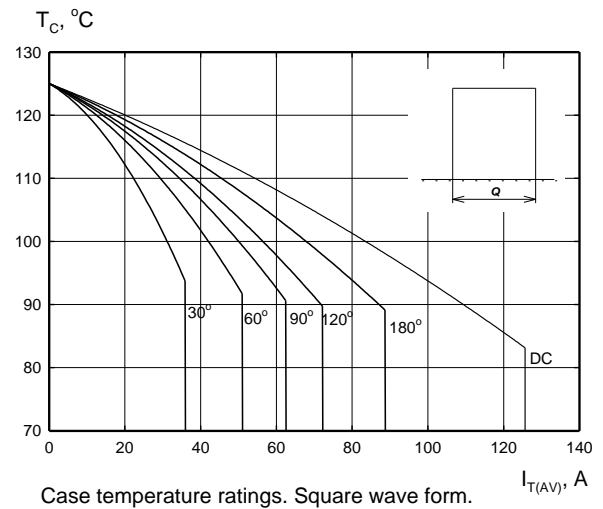
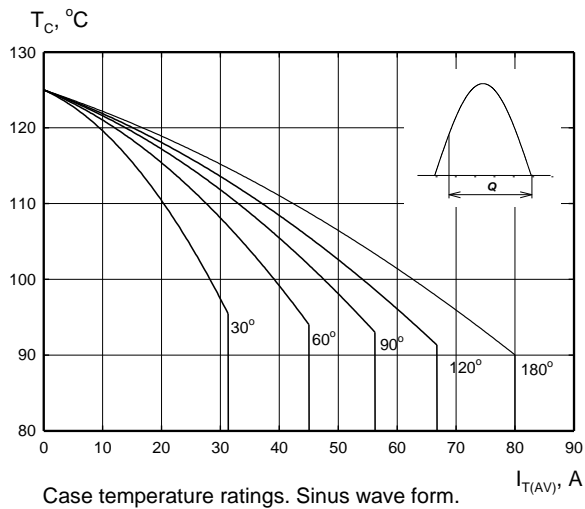
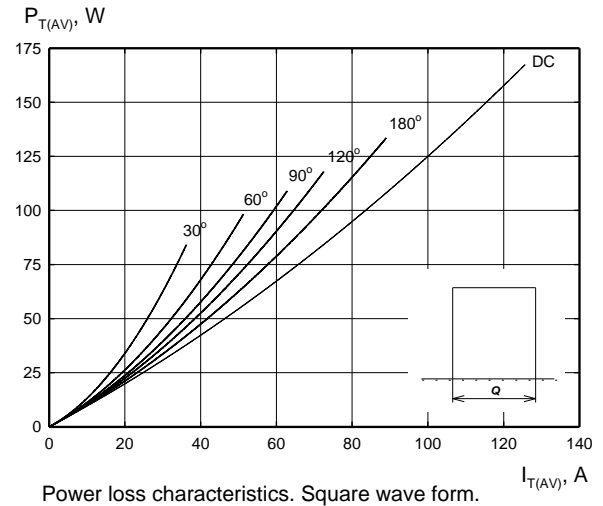
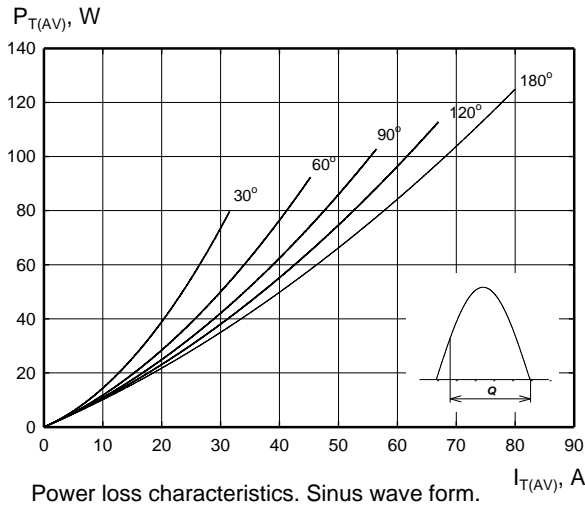

Zakłady Elektronowe LAMINA S.A.
Puławska 34
PL-05-500 Piaseczno
POLAND

Tel.: +48-22-7572731
Tel.: +48-22-3989409
Fax.: +48-22-3989407
e-mail: sekretariat@lamina.com.pl
www.lamina.com.pl

T51-80

Phase Control Thyristor

KKT5180, January 2007 version

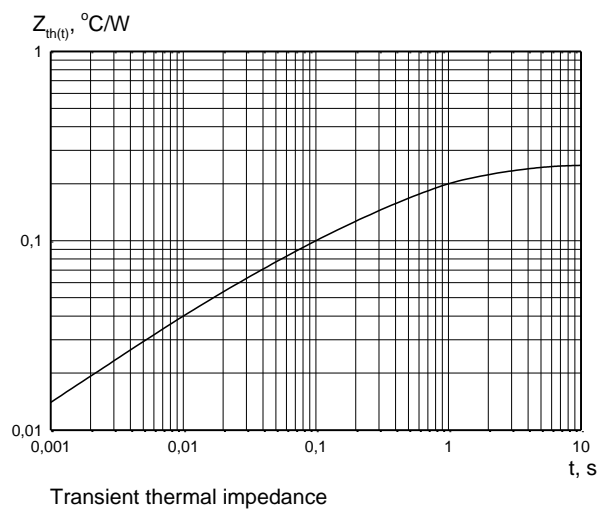
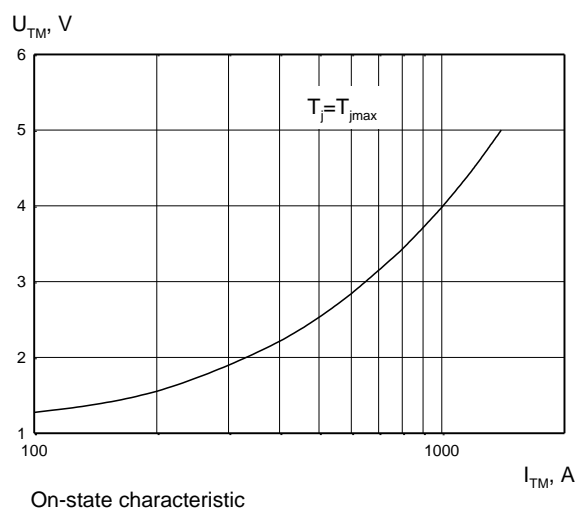
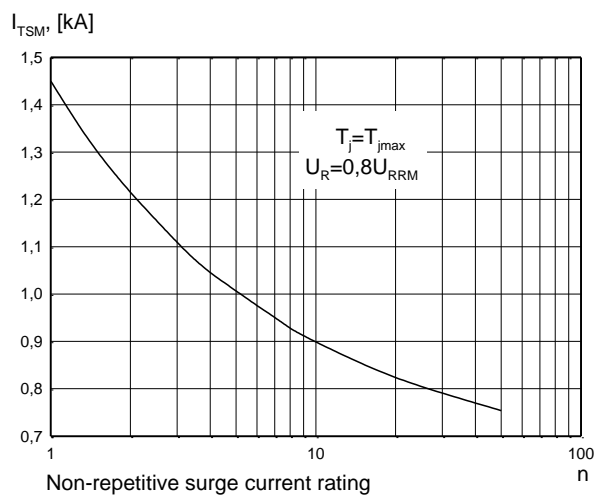

T51-80

Phase Control Thyristor

KKT5180, January 2007 version

Gate characteristics

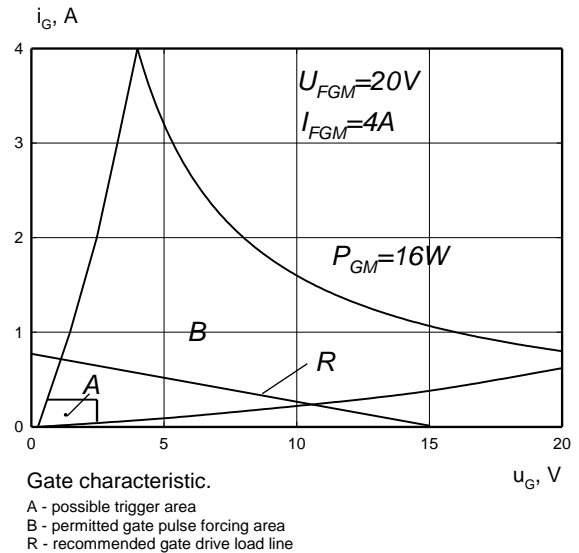
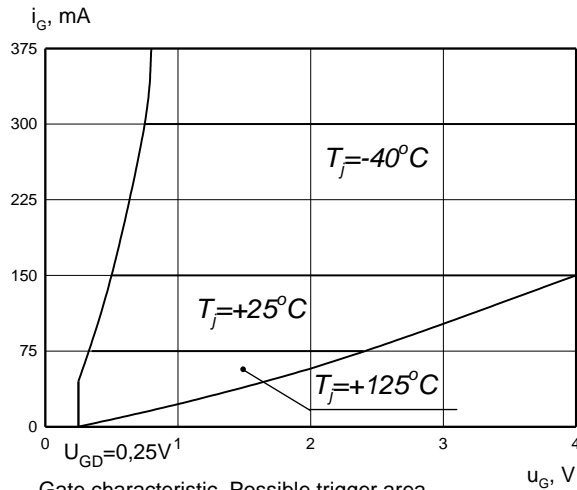

HEATSINKS

LAMINA S.I. has its own proprietary range of extruded aluminium heatsinks designed to optimise the performance of our semiconductors with natural and forced air flow. High efficiency water cooled copper heatsinks are also available.

POWER ASSEMBLY CAPABILITY

LAMINA S.I. provides a support for those customers requiring more than a basic semiconductor and offers precisely assembled Power Blocks according to factory or customer standards.

X-ON Electronics

Largest Supplier of Electrical and Electronic Components

Click to view similar products for [SCRs category](#):

Click to view products by [KUBARA LAMINA manufacturer](#):

Other Similar products are found below :

[NTE5428](#) [NTE5448](#) [NTE5457](#) [NTE5511](#) [T1500N16TOF VT](#) [T720N18TOF](#) [T880N14TOF](#) [T880N16TOF](#) [TN1205H-6G](#) [TN1215-800B-TR](#)
[TS110-7UF](#) [TT104N12KOF-A](#) [TT104N12KOF-K](#) [TT162N16KOF-A](#) [TT162N16KOF-K](#) [TT330N16AOF](#) [VS-111RKI120PBF](#) [VS-16RIA100](#)
[VS-22RIA20](#) [VS-2N5206](#) [VS-2N685](#) [VS-40TPS08A-M3](#) [VS-50RIA10](#) [057219R](#) [T1190N16TOF VT](#) [T1220N22TOF VT](#) [T201N70TOH](#)
[T830N14TOF](#) [T830N18TOF](#) [TD92N16KOF-A](#) [TT250N12KOF-K](#) [VS-ST180S12P0V](#) [VS-25RIA40](#) [VS-16RIA120](#) [VS-30TPS08PBF](#)
[TN1215-800G-TR](#) [NTE5427](#) [NTE5442](#) [X0405NF 1AA2](#) [VS-ST300S20P0PBF](#) [T2160N28TOF VT](#) [TT251N16KOF-K](#) [VS-22RIA100](#) [VS-](#)
[16RIA40](#) [CR02AM-8#F00](#) [VS-ST110S12P0VPBF](#) [TD250N16KOF-A](#) [GA301A](#) [VS-ST110S16P0](#) [VS-10RIA10](#)