

Dual-Phase PWM Controller for GPU Core Power Supply

General Description

The RT2701 is a dual-phase synchronous Buck PWM controller with integrated drivers which are optimized for high performance graphic microprocessor and computer applications. The IC integrates a PWM controller, two 12V MOSFET drivers with internal bootstrap diodes, as well as output current monitoring and protection functions into the WQFN-24L 4x4 package. The RT2701 adopts DCR and $R_{DS(ON)}$ current sensing. Over current protection is accomplished through continuous inductor DCR current sensing, while $R_{DS(ON)}$ current sensing is used for accurate channel current balance. Using both methods of current sampling utilizes the best advantages of each technique. The RT2701 also features an one-bit VID control operation in which the feedback voltage is regulated and tracks external input reference voltage. Other features include adjustable operating frequency, external compensation and enable/shutdown functions.

Ordering Information

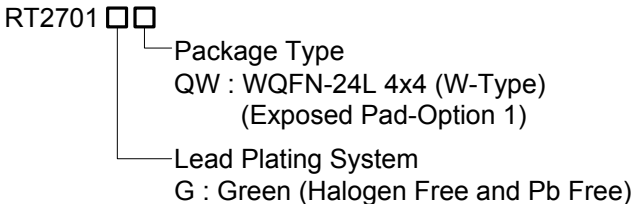

Note :

Richtek products are :

- ▶ RoHS compliant and compatible with the current requirements of IPC/JEDEC J-STD-020.
- ▶ Suitable for use in SnPb or Pb-free soldering processes.

Features

- Dual-Phase PWM Controller
- Two Embedded MOSFET Drivers and Embedded Switching Boot Diode
- Dynamic Auto Phase Control with Adjustable Threshold
- Cross-talk Jitter Suspend (CJS™)
- Remote GND Detection for High Accuracy
- Automatic Diode Emulation Mode/Or Ultrasonic Mode at Light Load
- Lossless $R_{DS(ON)}$ Current Sensing for Current Balance
- Lossless DCR Current Sensing for AVP & OCP
- Reference Voltage Output with 1% Accuracy
- External Reference Input with Soft-Start (RISS)
- Embedded One-Bit VID Control
- Adjustable OCP Threshold
- Adjustable Switching Frequency
- Reference Tracking UVP/OVP Protection
- Shoot Through Protection and Short Pulse Free Technology
- RoHS Compliant and Halogen Free

Applications

- Middle to High End GPU Core Power
- High End Desktop PC Memory Core Power
- Low Voltage, High Current DC/DC Converter
- Voltage Regulator Modules

Simplified Application Circuit

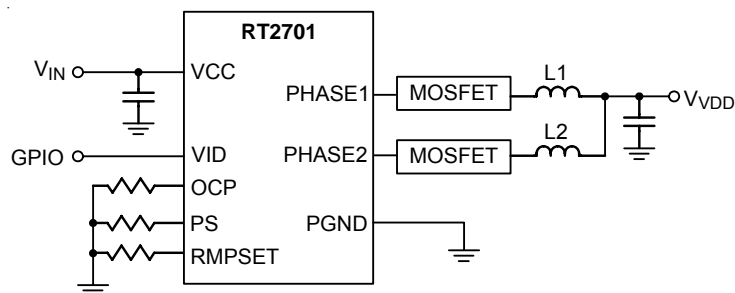

Pin Configurations

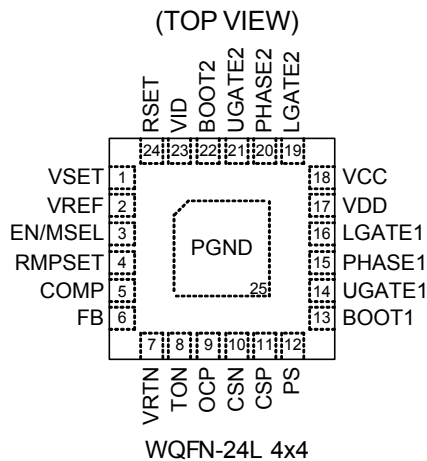

Marking Information

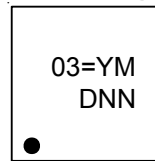

03= : Product Code
YMDNN : Date Code

Functional Pin Description

Pin No.	Pin Name	Pin Function
1	VSET	Output Voltage Setting. Connect a voltage divider from VREF to VSET to set the output voltage.
2	VREF	Reference Voltage Output (2V). The RT2701 generates a 2V reference voltage from VREF to VRTN.
3	EN/MSEL	Enable Control Input and Mode Selection. This pin is a tri-state input. Pull up this pin to be higher than 4.2V, the controller operates in DEM mode. Pull up this pin to between 1.2V to 3V, the controller operates in ASM mode. Pull down this pin to GND, the controller will shutdown.
4	RMPSET	Internal Ramp Slew Rate Setting. Connect a resistor (R_{RMP}) from RMPSET to GND to the ramp slew rate. The value of R_{RMP} must be set equal to R_{TON} .
5	COMP	Compensation Node. This pin is the output node of the error amplifier.
6	FB	Feedback Voltage Input. This pin is the negative input node of the error amplifier.
7	VRTN	Remote Differential Feedback, Invert Input. This pin is the negative node of the differential remote voltage sensing.
8	TON	Switching Frequency Setting. Connect a resistor (R_{TON}) from TON to VIN to set the switching frequency. The value of R_{TON} must be set equal to R_{RMP} .
9	OCP	OCP Level Setting. Connect a resistor from OCP to GND to set the current limit threshold.
10	CSN	Negative Input of Current Sensing.
11	CSP	Positive Input of Current Sensing.
12	PS	Dynamic Phase Control Input. Connect a resistor from PS to GND to set the auto down phase threshold.
13	BOOT1	Bootstrap Supply for High Side MOSFET Driver of Phase1.
14	UGATE1	High Side Gate Driver of Phase1. Connect this pin to the Gate of high side MOSFET.
15	PHASE1	Return node of Phase1 High Side Driver. Connect this pin to the Source of high side MOSFET together with the drain of low side MOSFET and the inductor.
16	LGATE1	Low Side Gate Driver of Phase1. Connect this pin to the Gate of low side MOSFET.

Pin No.	Pin Name	Pin Function
17	VDD	Regulator Power for Internal Circuit. The regulated voltage provides power supply for all low voltage circuits.
18	VCC	Supply Voltage Input. Connect this pin to GND by a ceramic cap larger than 1 μ F.
19	LGATE2	Low Side Gate Driver of Phase2. Connect this pin to the Gate of low side MOSFET.
20	PHASE2	Return node of Phase2 High Side Driver. Connect this pin to the Source of high side MOSFET together with the Drain low side of MOSFET and the inductor.
21	UGATE2	High Side Gate Driver of Phase2. Connect this pin to the Gate of high side MOSFET.
22	BOOT2	Bootstrap Supply for High Side MOSFET Driver of Phase2.
23	VID	Programming Output Voltage Control. When VID pin is logic high, internal N-MOSFET that connected to RSET pin is turn on.
24	RSET	Output Voltage Setting. Connect a resistor from RSET pin to VSET pin, the output voltage can be switched two levels by driving VID pin.
25 (Exposed Pad)	PGND	Power Ground. The exposed pad must be soldered to a large PCB and connected to PGND for maximum power dissipation.

Function Block Diagram

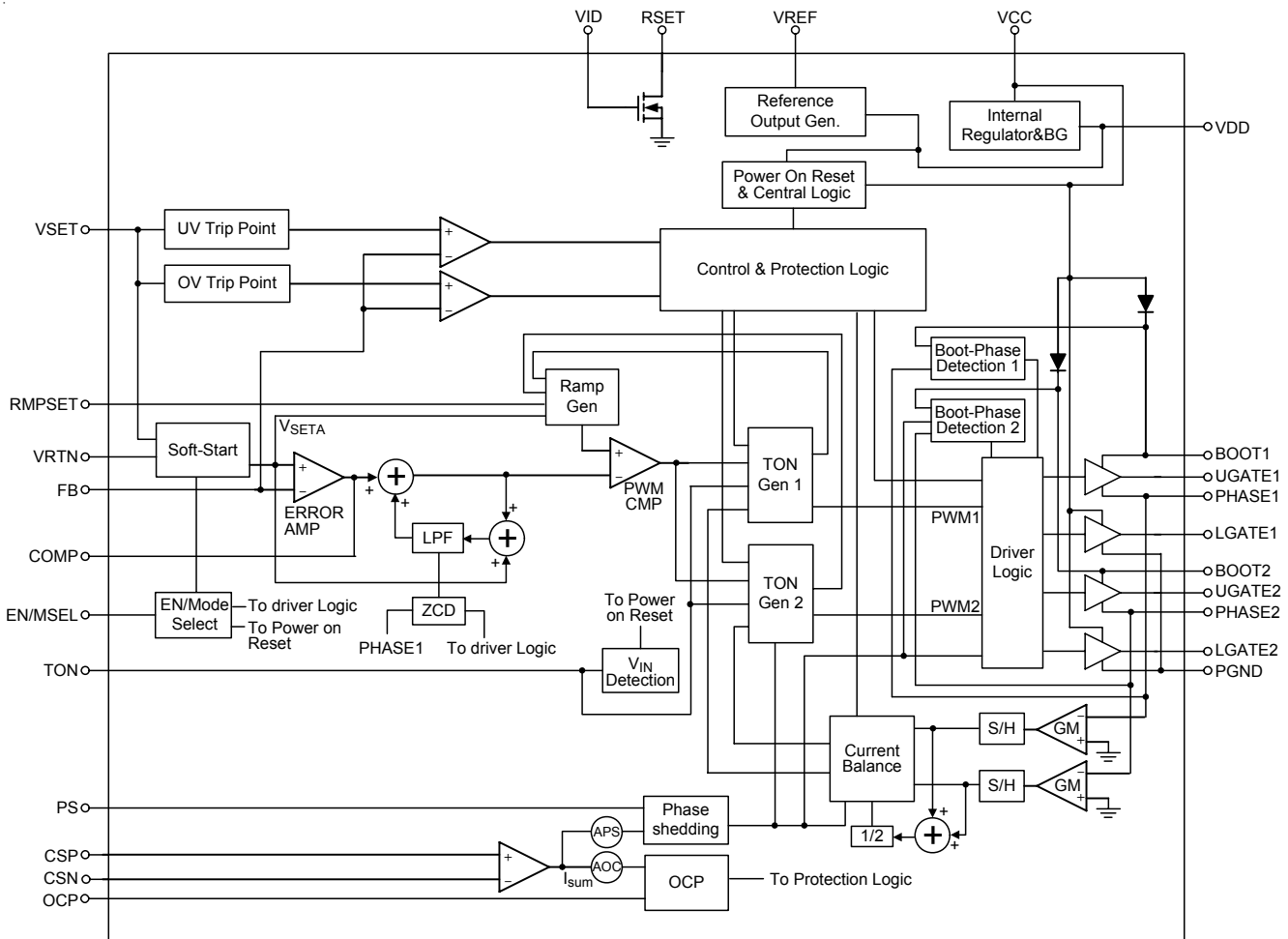

Operation

The RT2701 integrates a PWM controller, two 12V MOSFET drivers with internal bootstrap diodes, as well as output current monitoring and protection functions.

Power On Reset

The Power On Reset (POR) circuit monitors the supply voltage of the controller (VCC). When VCC exceeds the POR rising threshold, the controller will be enabled. If VCC falls below the POR falling threshold during normal operation, all MOSFETs stop switching. There is a hysteresis between the POR rising threshold and falling threshold to prevent noise mis-trigger.

Soft-Start

An internal soft-start function is used to prevent large inrush current while converter is powered-up. The FB voltage will track the internal soft-start voltage during soft-start interval. During the soft-start period, the controller will operate in dual-phase mode to ensure enough charge for output loads.

EN/Mode Select

The RT2701 supports DEM (Diode Emulation Mode) and ASM (Audio Skipping Mode) operation which can be enabled by EN/MSEL pin. When the EN/MSEL pin is pulled up above 4.2V, the controller will operate in DEM and reduce the switching frequency at light load conditions for saving power loss. If the EN/MSEL voltage is between 1.2V and 3V, the controller will operate in ASM. In ASM operation, the minimum switching frequency is limited to 30kHz to avoid acoustic noises. If the pin is pulled to GND, the RT2701 will be shut down.

Current Balance

The RT2701 implements internal current balance mechanism in the current loop. The RT2701 senses each phase current signal and compares it with the average current. If the sensed current of any particular phase is higher than average current, the on-time of this phase will be adjusted to be shorter.

OCP

Once the sensed total current exceeds the current limit threshold, the driver will be forced to turn off the gate drivers for high side power MOSFETs. Until the OCP situation is removed.

Over Voltage Protection

The RT2701 monitors the output voltage via the CSN pin for Over Voltage Protection (OVP). Once the output voltage exceeds the OVP threshold, the controller will turn off high side MOSFETs and turn on low side MOSFETs to protect the load until the OVP situation is removed.

Under Voltage Protection

The voltage on CSN pin is also monitored for Under Voltage Protection (UVP). If the output voltage is lower than the UVP threshold, the controller will turn off both high side and low side MOSFETs. When the UVP is triggered, the RT2701 will enter hiccup mode and continuously try to restart until the UVP situation is removed.

Absolute Maximum Ratings (Note 1)

- VDD, VSEN, COMP, VSET, VREF, EN/MSEL, PS, OCP, CSN, CSP, RSET, VID, RMPSET to PGND ----- -0.3V to 6V
- VCC, TON to PGND ----- -0.3V to 15V
- VRTN to PGND ----- -0.3V to 0.3V
- BOOTx to PHASEx ----- -0.3V to 15V
- PHASEx to PGND
 - DC ----- -3V to 15V
 - <20ns ----- -5V to 30V
- UGATEx to PHASEx
 - DC ----- -0.3V to BOOTx – PHASEx
 - <20ns ----- -5V to (BOOTx – PHASEx + 5V)
- LGATEx to PGND
 - DC ----- -0.3V to PVCC+ 0.3V
 - <20ns ----- -5V to (VCC + 5V)
- Power Dissipation, P_D @ T_A = 25°C
 - WQFN-24L 4x4 ----- 1.923W
- Package Thermal Resistance (Note 2)
 - WQFN-24L 4x4, θ_{JA} ----- 52°C/W
 - WQFN-24L 4x4, θ_{JC} ----- 7°C/W
- Junction Temperature ----- 150°C
- Lead Temperature (Soldering, 10 sec.) ----- 260°C
- Storage Temperature Range ----- -65°C to 150°C
- ESD Susceptibility (Note 3)
 - HBM (Human Body Model) ----- 2kV

Recommended Operating Conditions (Note 4)

- Supply Voltage, VCC ----- 4.5V to 13.2V
- Junction Temperature Range ----- -40°C to 125°C
- Ambient Temperature Range ----- -40°C to 85°C

Electrical Characteristics

(V_{CC} = 12V, No Load, T_A = -40°C to 85°C, unless otherwise specified)

Parameter	Symbol	Test Conditions	Min	Typ	Max	Unit
Supply Input						
Supply Current	I _{VCC} + I _{PVCC}	EN = 3.3V, Not Switching	--	3.5	5	mA
Shutdown Current	I _{CC} + I _{PVCC}	EN = 0V	--	--	600	μA
Power On Reset						
VCC POR Threshold	V _{VCC_th}	VCC Rising	--	4.2	4.5	V
Power On Reset Hysteresis	V _{VCC_hys}		--	0.3	--	V
Reference						
Reference Output	V _{REF}	(No Load, Active Mode)	1.98	2	2.02	V
Reference Input Range	V _{SET}	VSET pin (this max. voltage will affect V _{COMP} max.)	0.5	--	2	V
Start Up Delay						
Initial Soft-Start time	t _b	Initially, V _{OUT} = 0.1V to 1.2V	--	1.5	--	ms
Reference Change Delay Time	t _c		--	300	--	μs
Error Amplifier						
Input Offset Voltage	V _{OSEA}		-8	--	8	mV
DC Gain		R _L = 47kΩ	--	80	--	dB
Gain Bandwidth Product	GBW	C _{LOAD} = 5pF	--	10	--	MHz
Slew Rate	SR	C _{LOAD} = 10pF (Gain = -4, R _f = 47k, V _{OUT} = 0.5V to 3V)	--	5	--	V/μs
Output Voltage Range	V _{COMP}	R _L = 47kΩ (max. depend on VSET max.)	0.5	--	2	V
MAX Source Current	I _{OUTEA}	V _{COMP} = 2V	--	250	--	μA
Current Sense Amplifier (for Droop and OCP and Phase Shedding)						
Input Offset Voltage	V _{OCS}		-2	--	2	mV
Impedance at Neg. Input	R _{CSN}		1	--	--	MΩ
Impedance at Pos Input	R _{CSP}		1	--	--	MΩ
Maximum Input Range	V _{CSP} - V _{CSN}		--	--	65	mV
TON Setting						
On-Time Setting	t _{ON}	I _{RTON} = 62μA	315	350	385	ns
Protection						
Absolute Over Voltage Protection Threshold	V _{OVABS}	With Respect to V _{OUT(MAX)}	2.1	2.2	--	V
Relative Over Voltage Protection Threshold	V _{REL_OV}	With Respect to V _{OUT}	--	138	--	%

Parameter	Symbol	Test Conditions	Min	Typ	Max	Unit
Under Voltage Protection Threshold	V _{UV}	Measured at V _{SENS} with Respect to Unloaded Output Voltage (UOV)	--	50%	--	%
Current Source by OCP Pin	I _{OCP}		7.2	8	8.8	μA
Logic Inputs						
EN Threshold Voltage	V _{IL}	Low Level (SD) (Hysteresis)	--	--	0.5	V
EN Pin Mode Select Voltage		ASM Mode	1.2	--	3	V
		DEM Mode	4.5	--	--	
Leakage Current of EN		EN = 0V	-1	--	5	μA
Auto Phase Control						
Current Source by PSI Pin	I _{PS}		--	8	--	μA
Maximum Duty Cycle						
UGATE Min. Off Time			--	500	--	ns
Gate Driver						
Upper Driver Sink	R _{UGATEsk}	V _{UGATEx} - V _{PHASEx} = 0.1V, I _{UGATEx} = 50mA	1	2	3.5	Ω
Lower Driver Sink	R _{LGATEsk}	V _{LGATEx} = 0.1V, I _{LGATEx} = 50mA	0.7	1.4	2.5	Ω
Internal Boost Charging Switch On-Resistance	R _{BOOT}	PVCC to BOOTx	--	20	--	Ω

Note 1. Stresses beyond those listed “Absolute Maximum Ratings” may cause permanent damage to the device. These are stress ratings only, and functional operation of the device at these or any other conditions beyond those indicated in the operational sections of the specifications is not implied. Exposure to absolute maximum rating conditions may affect device reliability.

Note 2. θ_{JA} is measured at T_A = 25°C on a high effective thermal conductivity four-layer test board per JEDEC 51-7. θ_{JC} is measured at the exposed pad of the package.

Note 3. Devices are ESD sensitive. Handling precaution is recommended.

Note 4. The device is not guaranteed to function outside its operating conditions.

Typical Application Circuit

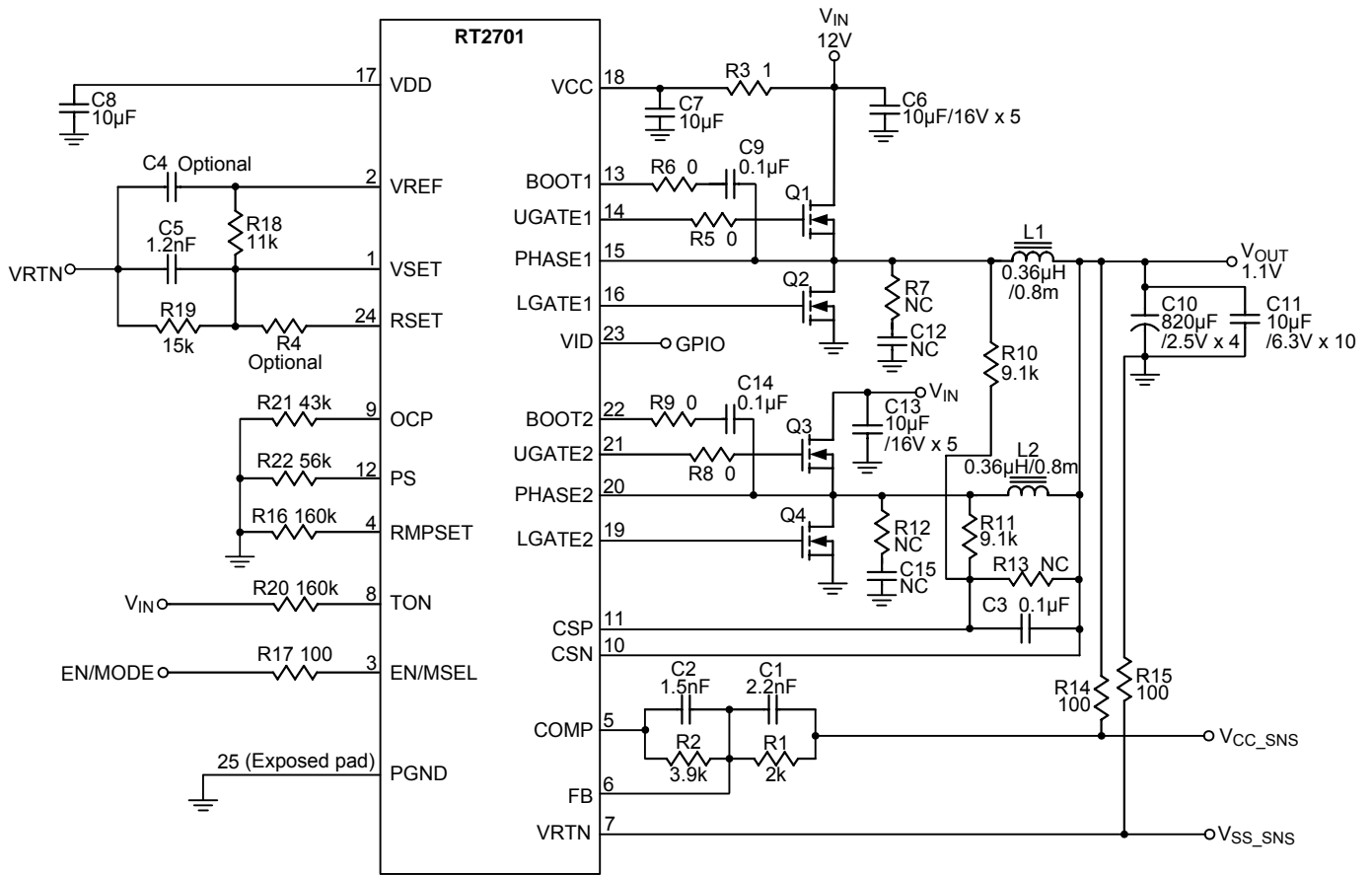

Typical Operating Characteristics

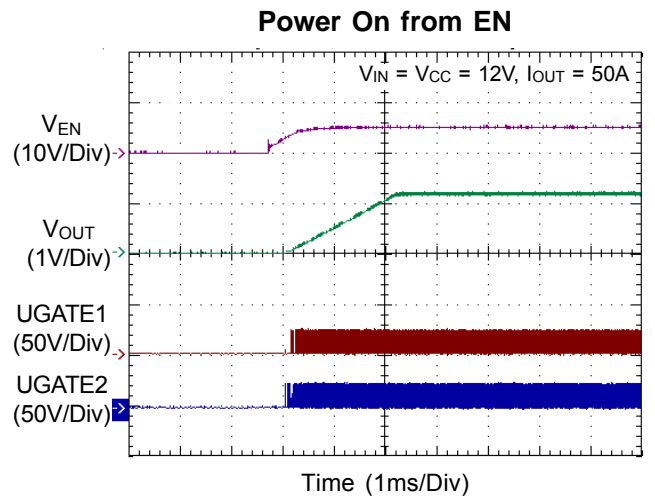
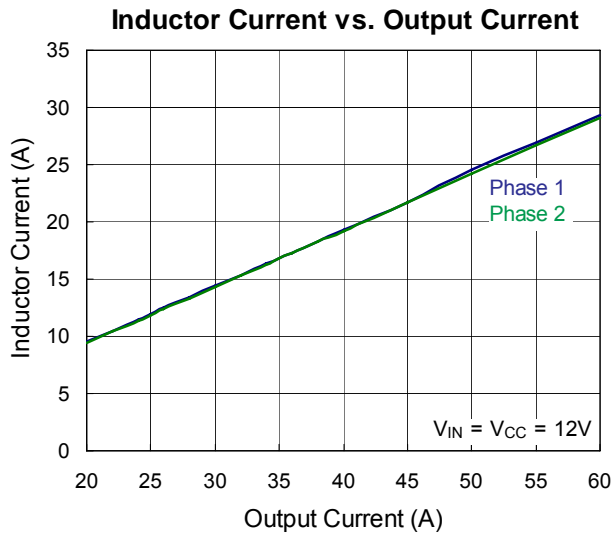
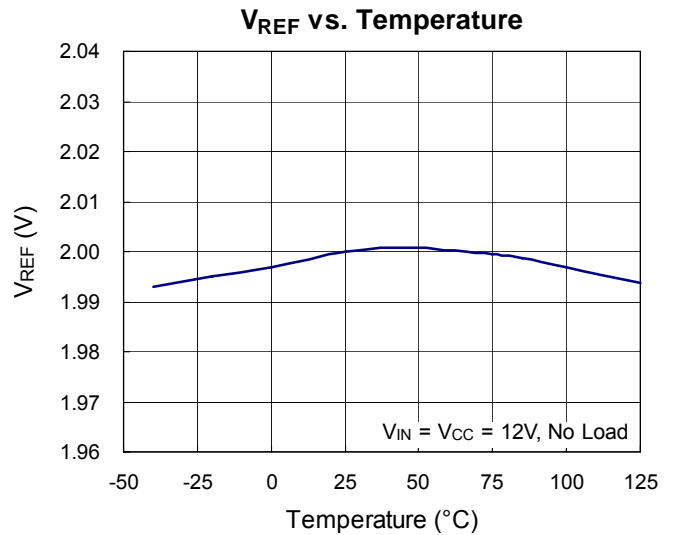
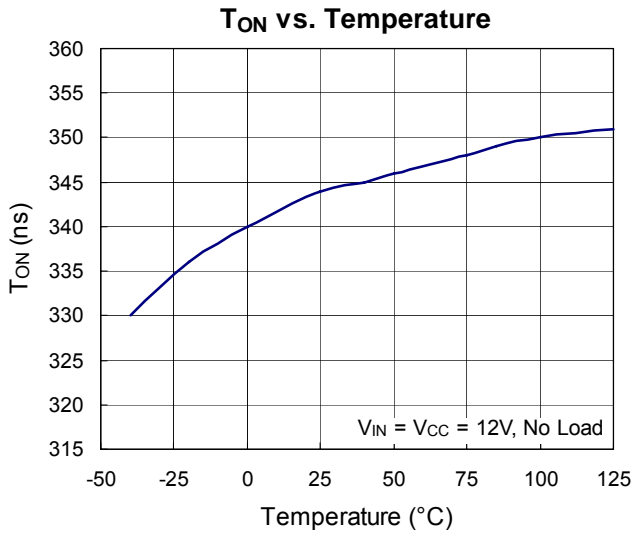
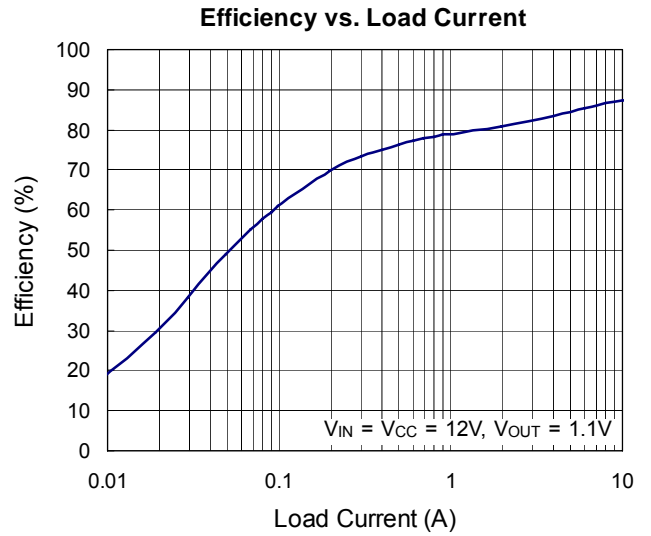
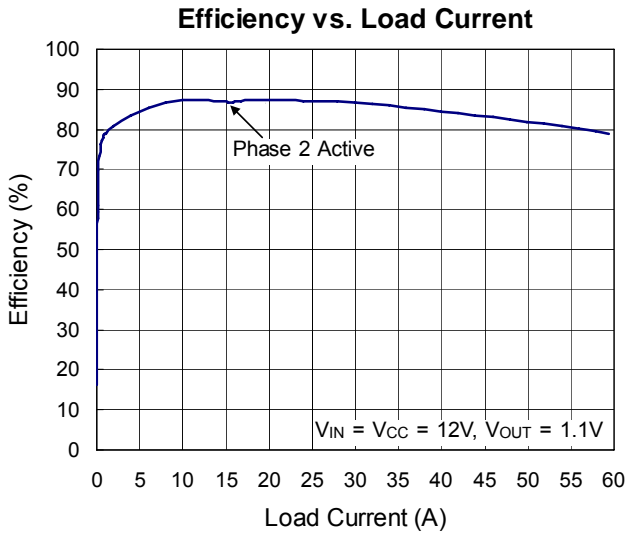

Power Off from EN

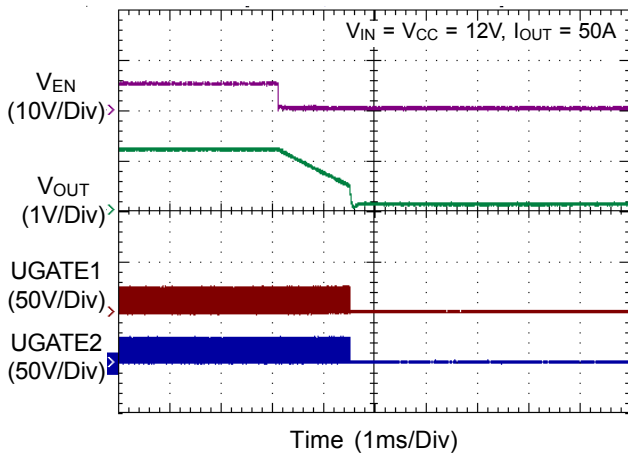

Power On from VCC

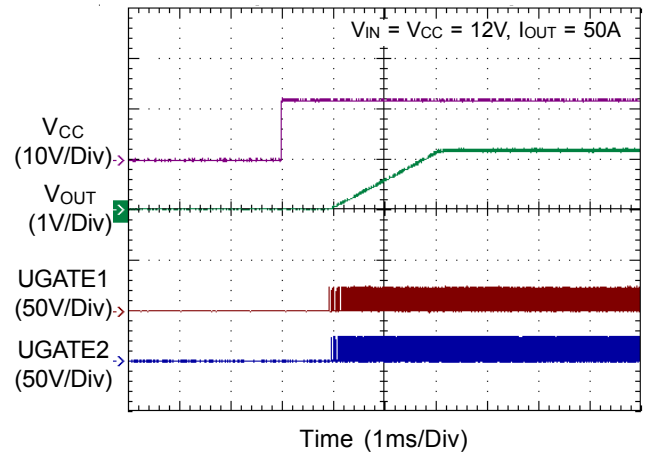

Power Off from VCC

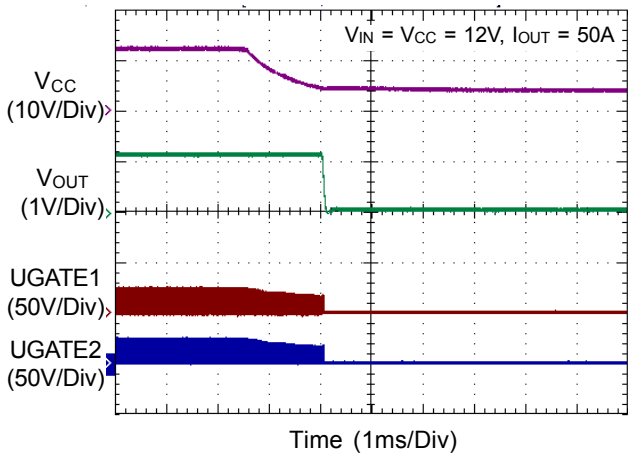

Dynamic Output Voltage Control

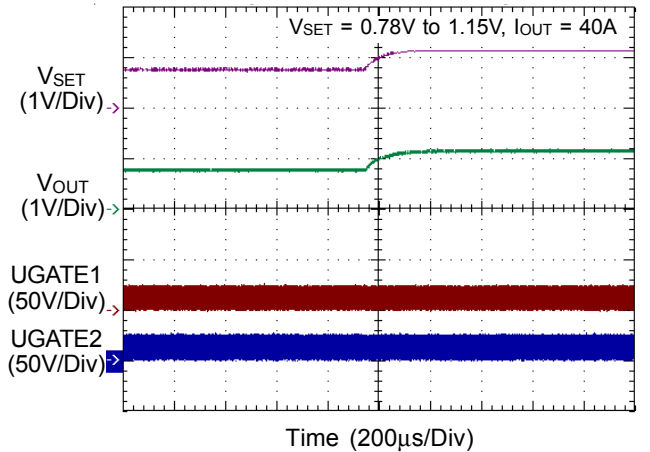

Dynamic Output Voltage Control

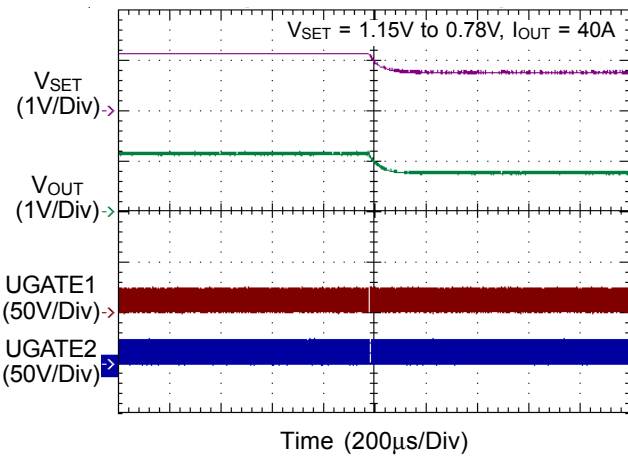

Load Transient Response

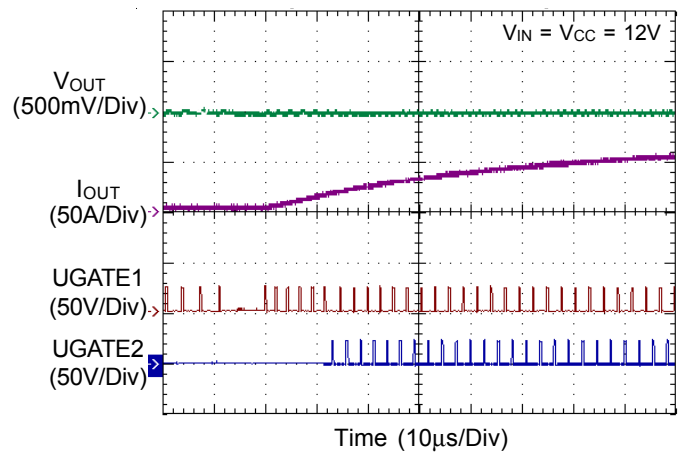

Load Transient Response

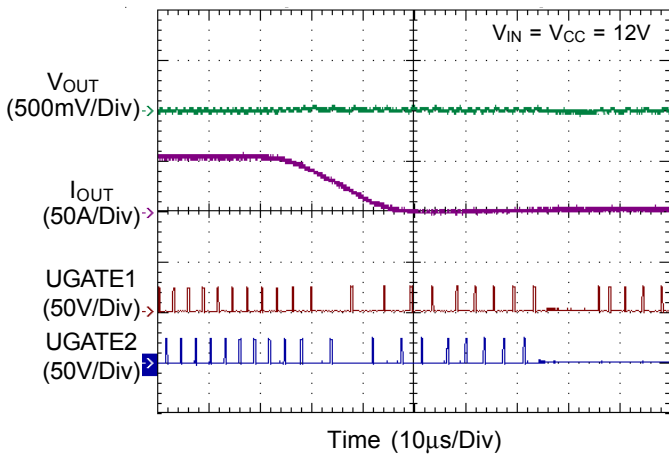

OVP

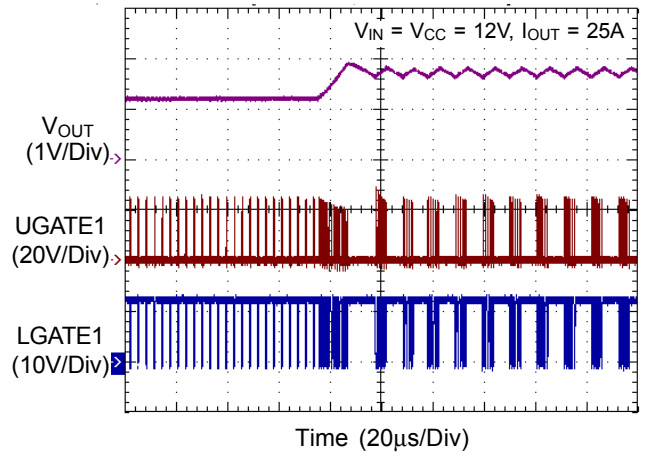

UVP

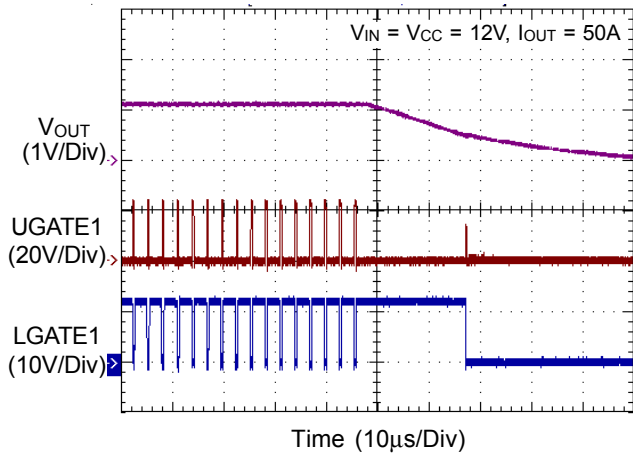

Short Circuit

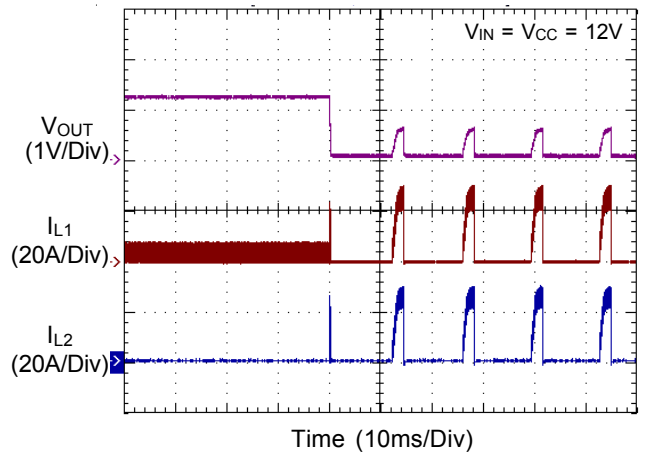

Application Information

The RT2701 is a dual-phase synchronous Buck PWM controller with integrated drivers which is optimized for high-performance graphic microprocessor and computer applications. A COT (Constant-On-Time) PWM controller and two 12V MOSFET drivers with internal bootstrap diodes are integrated so that the external circuit can be easily designed and the component count can be reduced.

The IC also adopts lossless DCR and $R_{DS(ON)}$ current sensing. Dynamic phase control and current limit are accomplished through continuous inductor DCR current sensing, while $R_{DS(ON)}$ current sensing is used for accurate channel current balance.

Dynamic mode transition function with various operating states, which include dual-phase, single phase, diode emulation and audio skipping modes is supported. These different operating states make the system efficiency as high as possible.

A one-bit VID control operation in which the feedback voltage is regulated and tracks external input reference voltage is provided. The RT2701 also features complete fault protection functions including over voltage, under voltage and current limit.

DEM/ASM Mode Selection

DEM (Diode Emulation Mode) and ASM (Audio Skipping Mode) operation can be enabled by driving the tri-state EN/MSEL pin to a logic high level. The RT2701 can switch operation into DEM when EN/MSEL pin is pulled up to above 4.2V. In DEM operation, the RT2701 automatically reduces the operation frequency at light load conditions for saving power loss. If EN/MSEL is pulled between 1.2V to 3V, the controller will switch operation into ASM. In ASM operation, the minimum switching frequency is limited to 30kHz to avoid the acoustic noise. Finally, if the pin is pulled to GND, the RT2701 will shutdown.

Power On Reset

The POR (power on reset) circuit monitors the supply voltage of the controller (V_{CC}). When V_{CC} exceeds the POR rising threshold, the controller will be enabled. During soft-start period, the output voltage will first boot to around 1V, and directly ramp to the set level. If V_{CC} falls below

the POR falling threshold during normal operation, all MOSFETs stop switching and the controller resets. The POR rising and falling threshold has a hysteresis to prevent noise mis-trigger.

Soft-Start

The RT2701 provides soft-start function. The soft-start function is used to prevent large inrush current while converter is being powered-up. The FB voltage will track the internal soft-start voltage during soft-start interval. Therefore, the duty cycle of the UGATE signal at power up as well as the input current limited. During the soft-start period, the controller will be in dual-phase operation by default to ensure enough charge during start-up.

One-Bit VID and Dynamic Output Voltage Control

The output voltage is determined by the applied voltage on the VSET pin. The RT2701 generates a 2V reference voltage from VREF to VRTN. As shown in Figure 1, connecting a resistive divider from the VREF pin to the VSET pin can set the output voltage according to the equation below :

$$V_{OUT} = 2V \times \left(\frac{R2}{R1 + R2} \right)$$

The RT2701 also features a one-bit VID control through an internal N-MOSFET also shown in Figure 1. Connecting a resistor ($R3$) from RSET pin to VSET pin, the output voltage can be switched between two levels by controlling the VID pin. When the VID pin is logic high, the internal N-MOSFET turns on to set the output voltage to a lower level. The output voltage can be calculated as below :

$$V_{OUT} = 2V \times \left[\frac{(R2 // R3)}{R1 + (R2 // R3)} \right]$$

The available setting range of the VSET voltage is from 0.5V to 2V.

One-Bit VID and Dynamic Output Voltage Control

For the RT2701, it can be set lower than 10mV/ μ s by C_{VSET} as shown in Figure 1. That is, assume the $\Delta V_{OUT} = 300mV$, $R1 = 11k\Omega$, $R2 = R3 = 27k\Omega$, the desired slew rate at falling is $SR_F = 10mV/\mu s$, and the C_{VSET} can be calculated by the formula below :

$$C_{VSET} = \frac{\Delta V_{OUT}}{5 \times (R1 // R2 // R3) \times SR_F} = 1nF$$

And then, the rising slew rate SR_R will be

$$SR_R = \frac{\Delta V_{OUT}}{5 \times (R1 // R2) \times C_{VSET}} = 7.67 \text{mV}/\mu\text{s}$$

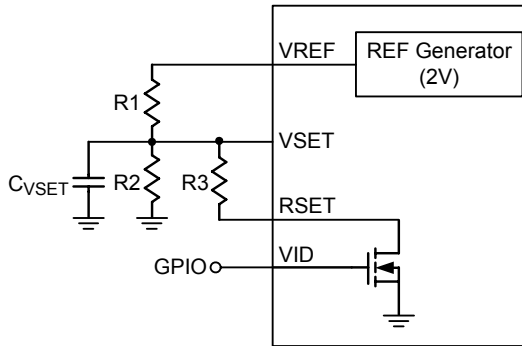

Figure 1. Output Voltage Setting with One Bit VID Control

Switching Frequency Setting

Switching frequency is a trade-off between efficiency and converter size. Higher operation frequency allows the use of smaller components. This is common in ultra portable devices where the load currents are lower and the controller is powered from a lower voltage supply. On the other hand, lower frequency operation offers higher overall efficiency at the expense of component size and board space. Figure 2 shows the On-Time Setting Circuit. Connect a resistor (R_{TON}) from TON to V_{IN} and a resistor (R_{RMP}) from RMPSET to GND to set the switching frequency according to the formula below :

$$R_{TON} = \frac{V_{IN} - V_{SET}}{f_S \times C \times V_{REF}} \times \frac{V_{SET} + I_L \times (R_{DS(ON)_L-MOS} + R_{DC} - R_{LL})}{V_{IN} + I_L \times (R_{DS(ON)_L-MOS} - R_{DS(ON)_H-MOS})}$$

Where

- f_S : Switching frequency
- R_{TON} : TON setting resistor
- C : Capacitance for on time compute (13.7pF)
- V_{REF} : Reference voltage for on time compute
- I_L : Inductor current
- $R_{DS(ON)_L-MOS}$: $R_{DS(ON)}$ of Low Side MOSFET
- $R_{DS(ON)_H-MOS}$: $R_{DS(ON)}$ of High Side MOSFET

R_{DC} : DCR of inductor

R_{LL} : Load line resistance

The value of R_{TON} can be selected using Figure 3 and the value of R_{RMP} must be set equal to R_{TON} .

The current through R_{TON} should be set between $30\mu\text{A}$ to $280\mu\text{A}$.

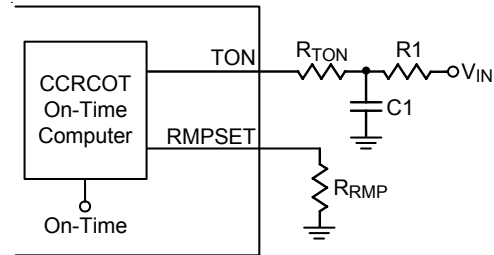

Figure 2. On-Time Setting with RC Filter

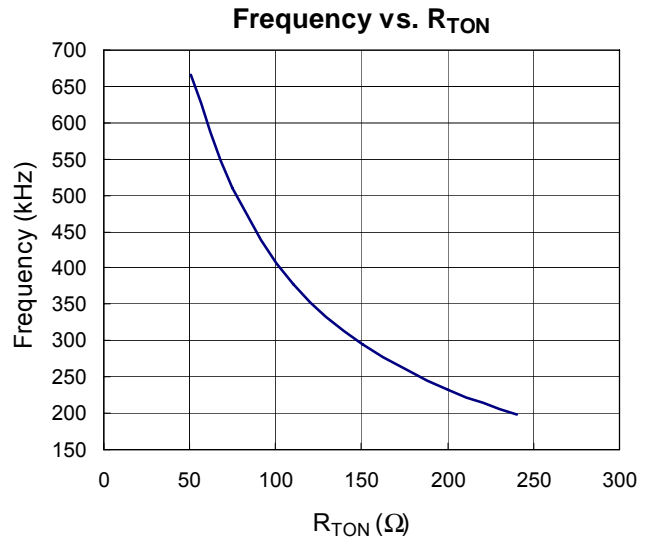

Figure 3. Frequency vs. R_{TON}

Current Sense Setting (with Temperature Compensation)

The RT2701 uses continuous inductor current sensing to make the controller less noise sensitive. Low offset amplifiers are used for loop control and over current detection. The CSP and CSN denote the positive and negative input of the current sense amplifier of any phase. Since the DCR of the inductor is temperature dependent, it affects the down phase threshold, OCP threshold and output voltage accuracy, especially at heavy load. Temperature compensation is recommended for the lossless inductor DCR current sense method. Figure 4

shows a simple but effective way to compensate the unwanted temperature variations of the inductor DCR by using an NTC thermistor.

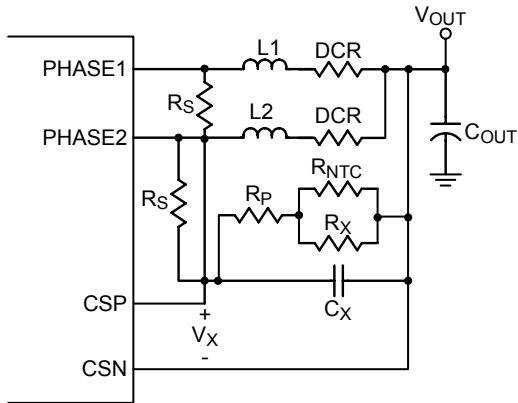

Figure 4. Inductor DCR Sensing

The RT2701 observes the voltage V_X , across the CSP and CSN pins for inductor current information. To design V_X without regard to the temperature coefficient, refer to the formula below :

$$\frac{DCR_{TH}}{DCR_{TL}} = \frac{2 + \frac{R_S}{R_{EQU_TH}}}{2 + \frac{R_S}{R_{EQU_TL}}} \quad (1)$$

where R_{EQU_TH} is equal to $R_P + R_{NTC} // R_X$ at high temperature and R_{EQU_TL} is equal to $R_P + R_{NTC} // R_X$ at low temperature. Usually, R_X is set to equal R_{NTC} (25°C). R_P and R_X are selected to linearize the NTC's temperature characteristic. For a given NTC and R_P , the design is to first obtain R_S and then C_X . Usually, set $R_X = R_{NTC}$. To solve (1), R_S must first be obtained as below :

$$R_S = \frac{2(\alpha - 1)}{\frac{1}{R_{EQU_TH}} - \frac{\alpha}{R_{EQU_TL}}} \quad (2)$$

Where α is equal to DCR_{TH}/DCR_{TL}

The standard formula for the resistance of the NTC thermistor as a function of temperature is given by :

$$R_{NTC, T^\circ C} = R_{25^\circ C} \times e^{\left\{ \beta \left[\left(\frac{1}{T+273} \right) - \left(\frac{1}{278} \right) \right] \right\}} \quad (3)$$

where $R_{25^\circ C}$ is the thermistor's nominal resistance at room temperature, β (beta) is the thermistor's material constant in Kelvins, and T is the thermistor's actual temperature in Celsius.

To calculate DCR value at different temperatures, can use the equation below :

$$DCR_{T^\circ C} = DCR_{25^\circ C} \times [1 + 0.00393 \times (T - 25)] \quad (4)$$

where the 0.00393 is the temperature coefficient of copper.

C_X can be obtained by below formula,

$$C_X = \frac{L_X \left(2 + \frac{R_S}{R_{EQU_25^\circ C}} \right)}{R_S \times DCR_{25^\circ C}} \quad (5)$$

Loop Compensation

Optimized compensation of the RT2701 allows for best possible load step response of the regulator's output. A type-I compensator with a single pole and single zero is adequate for a proper compensation. Figure 5 shows the compensation circuit. Prior design procedure shows how to determine the resistive feedback components of the error amplifier gain, C1 and C2 must be calculated for the compensation. The target is to achieve the constant resistive output impedance over the widest possible frequency range. The pole frequency, f_P , of the compensator must be set to compensate the output capacitor ESR zero :

$$f_P = \frac{1}{2\pi \times R_C \times C} \quad (6)$$

where C is the capacitance of the output capacitor, and R_C is the ESR of output capacitor. C2 can be calculated as follows :

$$C2 = \frac{R_C \times C}{R2} \quad (7)$$

The zero of compensator has to be placed at half of the switching frequency to filter the switching related noise, such that,

$$C1 = \frac{1}{R1 \times \pi \times f_S} \quad (8)$$

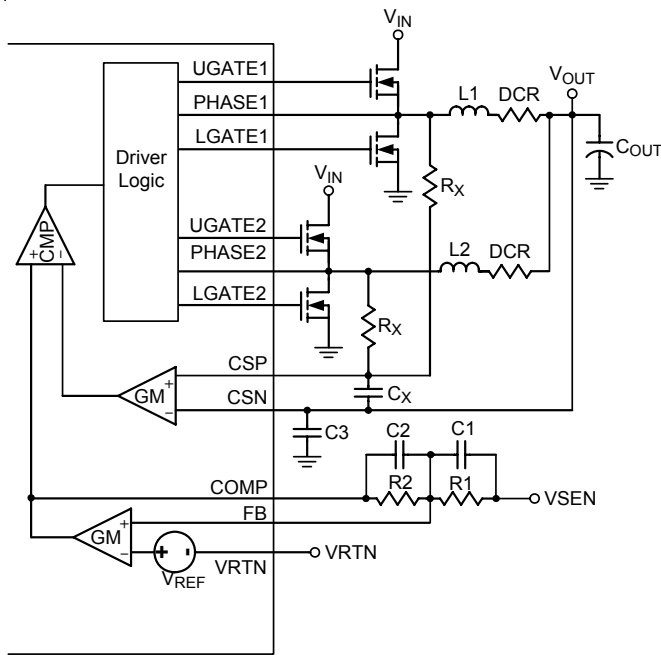

Figure 5. Compensation Circuit

Dynamic Phase Number Control

The RT2701 controls the operation phase number according to the total current. Figure 6 shows the dynamic phase number control circuit. By connecting a resistor (R_{PS}) from the PS pin to GND, the phase transition threshold can be set. The formula is :

$$R_{PS} = \frac{DCR \times I_{SUM} \times 5}{1\mu}$$

where I_{SUM} is the sum of the inductor valley current. For example, if DCR is 0.74mΩ, and the desired up phase threshold is 15A, the value of R_{PS} will be

$$R_{PS} = \frac{0.74 \times 10^{-3} \times 15 \times 5}{1 \times 10^{-6}} = 55.5k\Omega$$

Once the total inductor valley current is higher than the threshold, the controller will transit to dual-phase operation. when the total current becomes lower than the setting threshold minus around 5A hysteresis, the active phase number will return to single phase. If the PS pin is set floating, the controller will force to dual-phase operation.

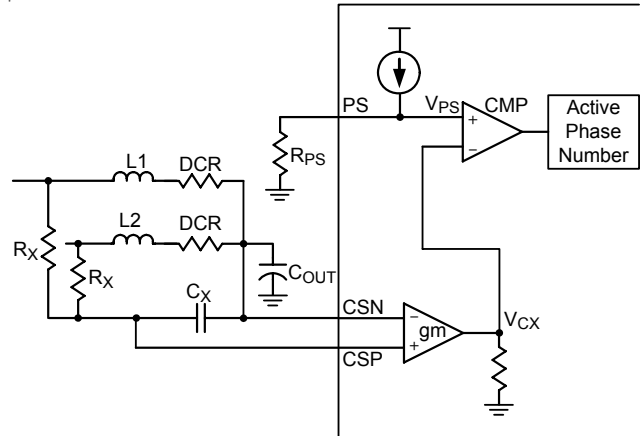

Figure 6. Dynamic Phase Number Control Circuit

Current Balance

The RT2701 implements internal current balance mechanism in the current loop. The RT2701 senses per phase current signal and compares it with the average current. If the sensed current of any particular phase is higher than average current, the on-time of this phase will be adjusted to be shorter.

Current Limit Setting

The RT2701 includes a built-in current limit protection function. Figure 7 shows the protection circuit. The current limit threshold is adjusted by an external resistor, R_{OC} , at the OCP pin. The value of R_{OC} can be set according to the following formula :

$$R_{OC} = \frac{DCR \times I_{SUM} \times 6}{8\mu}$$

where I_{SUM} is the desired current limit threshold. Once the sensed total current exceeds the current limit threshold, the driver will be forced to turn off UGATE until the OCP situation is removed.

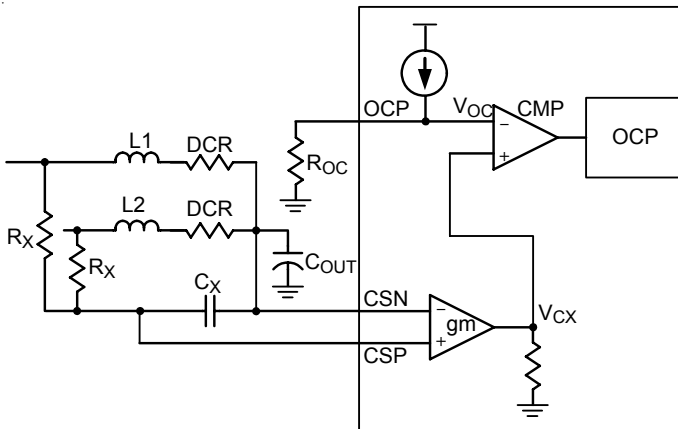

Figure 7. Over Current Protection Circuit

Over Voltage Protection

The RT2701 monitors the output voltage via the CSN pin for Over Voltage Protection (OVP). Once the output voltage exceeds the OVP threshold, OVP is triggered. The RT2701 will turn on low side MOSFETs and turn off high side MOSFETs to protect the load until the OVP situation is removed. A 4µs delay is used in the OVP detection circuit to prevent false trigger.

Under Voltage Protection

The voltage on CSN pin is also monitored for under voltage protection. If the output voltage is lower than the UVP threshold, UVP will be triggered. The RT2701 will then turn off both high side and low side MOSFETs. When UVP is triggered, the RT2701 will enter hiccup mode and continuously try to restart until the UVP situation is cleared.

Inductor Selection

The switching frequency and ripple current determine the inductor value as follows :

$$L_{(MIN)} = \frac{V_{IN} - V_{OUT}}{I_{RIPPLE(MAX)}} \times T_{ON}$$

where T_{ON} is the UGATE turn on period.

Higher inductance results in lower ripple current and higher efficiency but brings slower load transient response. Thus, more output capacitors may be required. The lower DC resistance can reduce power loss. The core must be large enough and not to be saturated at the peak inductor current.

Output Capacitor Selection

Output capacitors are used to maintain high performance for the output beyond the bandwidth of the converter itself. Two different kinds of output capacitors can be found, bulk capacitors closely located to the inductors and ceramic output capacitors close to the load. The latter are for mid-frequency decoupling with especially small ESR and ESL values while the bulk capacitors have to provide enough stored energy to overcome the low-frequency bandwidth gap between the regulator and the GPU.

Thermal Considerations

For continuous operation, do not exceed absolute maximum junction temperature. The maximum power dissipation depends on the thermal resistance of the IC package, PCB layout, rate of surrounding airflow, and difference between junction and ambient temperature. The maximum power dissipation can be calculated by the following formula :

$$P_{D(MAX)} = (T_{J(MAX)} - T_A) / \theta_{JA}$$

where $T_{J(MAX)}$ is the maximum junction temperature, T_A is the ambient temperature, and θ_{JA} is the junction to ambient thermal resistance.

For recommended operating condition specifications, the maximum junction temperature is 125°C. The junction to ambient thermal resistance, θ_{JA} , is layout dependent. For WQFN-24L 4x4 package, the thermal resistance, θ_{JA} , is 52°C/W on a standard JEDEC 51-7 four-layer thermal test board. The maximum power dissipation at $T_A = 25^\circ\text{C}$ can be calculated by the following formula :

$$P_{D(MAX)} = (125^\circ\text{C} - 25^\circ\text{C}) / (52^\circ\text{C/W}) = 1.923\text{W for WQFN-24L 4x4 package}$$

The maximum power dissipation depends on the operating ambient temperature for fixed $T_{J(MAX)}$ and thermal resistance, θ_{JA} . The derating curve in Figure 8 allows the designer to see the effect of rising ambient temperature on the maximum power dissipation.

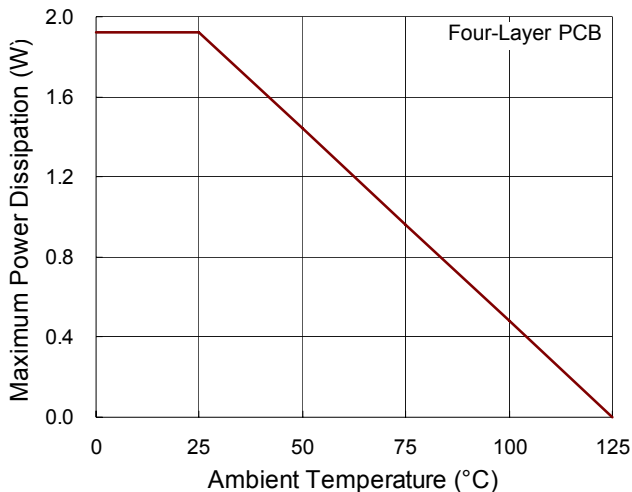

Figure 8. Derating Curve of Maximum Power Dissipation

Layout Considerations

Careful PC board layout is critical to achieving low switching losses and clean, stable operation. The switching power stage requires particular attention. If possible, mount all of the power components on the top side of the board with their ground terminals flushed against one another. Follow these guidelines for optimum PC board layout :

- ▶ Keep the high current paths short, especially at the ground terminals.
- ▶ Keep the power traces and load connections short. This is essential for high efficiency.
- ▶ When trade-offs in trace lengths must be made, it's preferable to allow the inductor charging path to be made longer than the discharging path.
- ▶ Place the current sense components close to the controller. CSP and CSN connections for current limit and voltage positioning must be made using Kelvin sense connections to guarantee the current sense accuracy. The PCB trace from the sense nodes should be paralleled back to the controller.
- ▶ Route high speed switching nodes away from sensitive analog areas (COMP, FB, CSP, CSN, etc...)

Outline Dimension

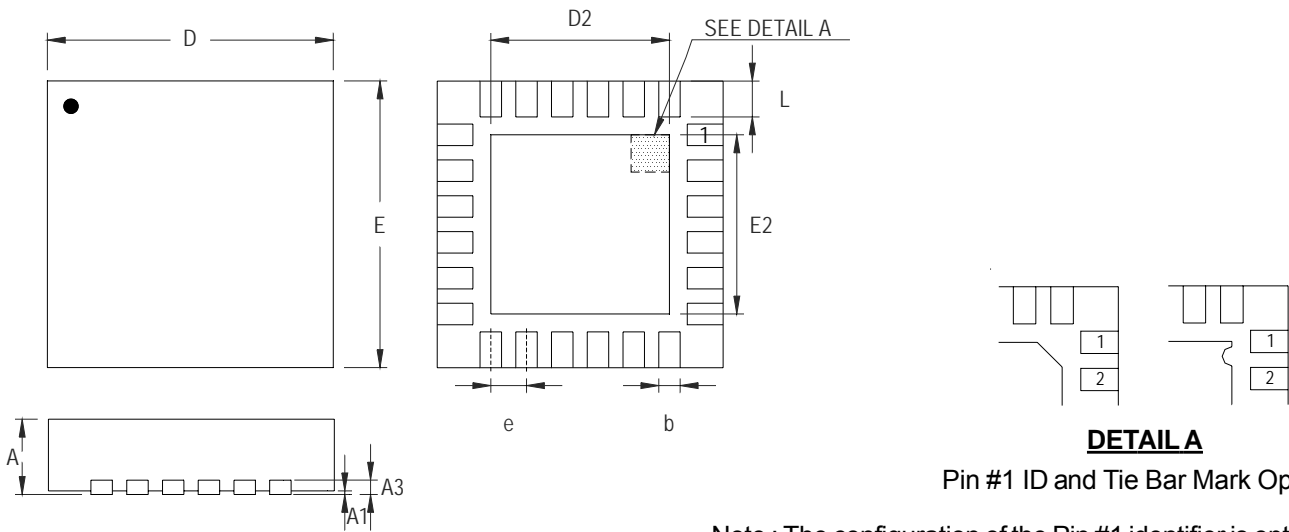

DETAIL A
Pin #1 ID and Tie Bar Mark Options

Note : The configuration of the Pin #1 identifier is optional, but must be located within the zone indicated.

Symbol	Dimensions In Millimeters		Dimensions In Inches		
	Min	Max	Min	Max	
A	0.700	0.800	0.028	0.031	
A1	0.000	0.050	0.000	0.002	
A3	0.175	0.250	0.007	0.010	
b	0.180	0.300	0.007	0.012	
D	3.950	4.050	0.156	0.159	
D2	Option 1	2.400	2.500	0.094	0.098
	Option 2	2.650	2.750	0.104	0.108
E	3.950	4.050	0.156	0.159	
E2	Option 1	2.400	2.500	0.094	0.098
	Option 2	2.650	2.750	0.104	0.108
e	0.500		0.020		
L	0.350	0.450	0.014	0.018	

W-Type 24L QFN 4x4 Package

Richtek Technology Corporation

5F, No. 20, Taiyuen Street, Chupei City
Hsinchu, Taiwan, R.O.C.
Tel: (8863)5526789

Richtek products are sold by description only. Richtek reserves the right to change the circuitry and/or specifications without notice at any time. Customers should obtain the latest relevant information and data sheets before placing orders and should verify that such information is current and complete. Richtek cannot assume responsibility for use of any circuitry other than circuitry entirely embodied in a Richtek product. Information furnished by Richtek is believed to be accurate and reliable. However, no responsibility is assumed by Richtek or its subsidiaries for its use; nor for any infringements of patents or other rights of third parties which may result from its use. No license is granted by implication or otherwise under any patent or patent rights of Richtek or its subsidiaries.

X-ON Electronics

Largest Supplier of Electrical and Electronic Components

Click to view similar products for [Richtek](#) manufacturer:

Other Similar products are found below :

[EVB_RT5047GSP](#) [EVB_RT7275GQW](#) [EVB_RT7297CHZSP](#) [RT9080N-08GJ5](#) [EVB_RT5047AGSP](#) [EVB_RT7243GQW](#)
[EVB_RT7272BGSP](#) [RT8097AHGE](#) [EVB_RT7247CHGSP](#) [EVB_RT7276GQW](#) [EVB_RT8293AHZSP](#) [EVB_RT6200GE](#)
[EVB_RT7235GQW](#) [EVB_RT7237AHGSP](#) [EVB_RT7251AZQW](#) [RT5047AGSP](#) [EVB_RT7272AGSP](#) [EVB_RT7237CHGSP](#)
[EVB_RT7247AHGSP](#) [EVB_RT7252BZSP](#) [EVB_RT7280GQW](#) [EVB_RT8292AHZSP](#) [EVB_RT8297BZQW](#) [EVB_RT7231GQW](#)
[EVB_RT7232GQW](#) [EVB_RT7236GQW](#) [EVB_RT7250BZSP](#) [EVB_RT7251BZQW](#) [EVB_RT7279GQW](#) [EVB_RT8008GB](#) [RT8207MZQW](#)
[RT8296AHZSP](#) [RT9011-JGPJ6](#) [RT8258GE](#) [RT5711AHGQW](#) [RT9081AGQZA\(2\)](#) [RT6154BGQW](#) [RT7238BGQUF](#) [RT5788AGJ8F](#)
[RT8812AGQW](#) [RT6278BHGQUF](#) [RT7270HZSP](#) [RD0004](#) [RT5789AGQUF](#) [RT9076-18GVN](#) [RT9193-15GU5](#) [RT3602AJGQW](#)
[RT8296BHZSP](#) [RT6214AHGJ6F](#) [RT9276GQW\(Z00\)](#)