



Thyristors type T95 are of modern design with pressure contacts, high alumina ceramic insulator and cold-welding encapsulation. Designed for use in power electronic circuits and equipment under normal operating conditions.

### KEY PARAMETERS

$U_{DRM}, U_{RRM}$	<b>up to 1600 V</b>
$I_{T(AV)}$	<b>1600 A</b>
$I_{TSM}$	<b>27000 A</b>
$du/dt^*$	<b>1000 V/<math>\mu</math>s</b>
$di/dt$	<b>200 A/<math>\mu</math>s</b>

\* maximum (non standard) value

### FEATURES

- all diffused design
- high current capabilities
- high surge current capabilities
- high rates voltages
- high  $du/dt$
- low gate current
- dynamic gate
- low thermal impedance
- tested according to IEC standards
- compact size and small weight

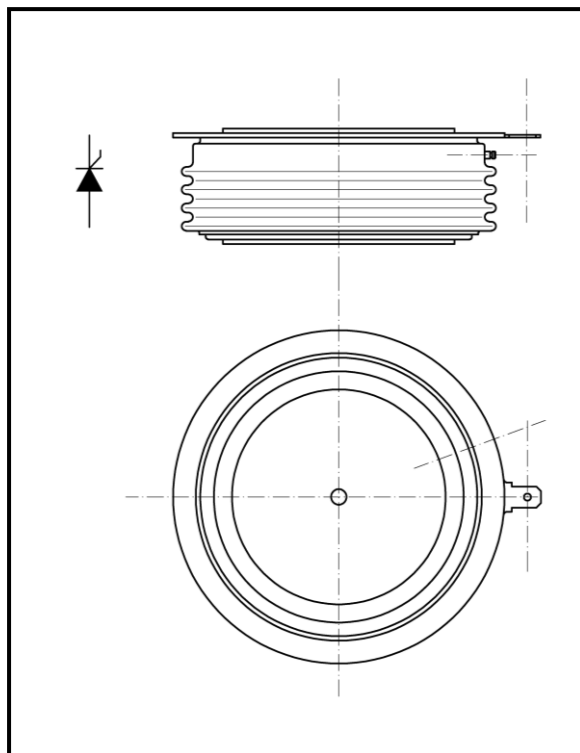

### APPLICATION

- High Power Drives
- DC Motor Control
- High Voltage Power Supplies

**Outline type code : A-24  
(K-puk)**  
See package details for further information

Designed for use in high power industrial and commercial power electronic circuits and equipment where high currents are encountered and high reliability is essential.

# T95-1600

## Phase Control Thyristor



KKT951600, November 2006 version

### ORDERING INFORMATION

When ordering please refer to device code builder presented below.

Please use the complete part number when ordering, quote or in any future correspondence relating to your order.

**T95-1600-**□□

└── voltage class (hundreds of volts)

This is standard device, with no dynamic parameters specified and standard accessory set.

Please refer to **Electrical Parameters** if specific dynamic demands have to be met.

Those information, as well as any other concerning non-standard accessories e.g. custom leads length or lead terminal connector type should be included in the order.

### ELECTRICAL PARAMETERS

#### Voltage ratings

Voltage class	$U_{DRM}, U_{RRM}$	$U_{DSM}, U_{RSM}$	$I_{DRM}, I_{RRM}$
	V	V	mA
04	400	500	100
06	600	700	
08	800	900	
10	1000	1100	
12	1200	1300	
14	1400	1500	
16	1600	1700	

#### dU/dt group codes

Group code	du/dt
	V/μs
0	no specified value
5	320
6	500
7	1000

Zakłady Elektronowe LAMINA S.A.  
Puławska 34  
PL-05-500 Piaseczno  
POLAND

Tel.: +48-22-7572731  
Tel.: +48-22-3989409  
Fax.: +48-22-3989407  
e-mail: sekretariat@lamina.com.pl  
www.lamina.com.pl

# T95-1600

## Phase Control Thyristor



Zakłady Elektronowe  
**LAMINA S.A.**

KKT951600, November 2006 version

### Electrical properties

Parameter	Unit	Test conditions	Value
Average on-state current	$I_{T(AV)}$	A	1600
Case temperature	$T_c$	°C	70
RMS on-state current	$I_{T(RMS)}$	A	2500
Surge on-state current	$I_{TSM}$	A	$T_j=125^\circ\text{C}$ , $U_R=0,8U_{RRM}$ , $t_p=10\text{ms}$
$I^2t$ – value	$I^2t$	$\text{kA}^2\text{s}$	3600
On-state voltage max.	$U_{TM}$	V	$T_j=25^\circ\text{C}$ , $I_{TM}=1500\text{A}$
Threshold voltage	$U_{T(T0)}$	V	0,78
Slope resistance	$r_T$	$\text{m}\Omega$	0,18
Latching current	$I_L$	mA	$T_j=25^\circ\text{C}$ , $U_D=12\text{V}$
Holding current	$I_H$	mA	$T_j=25^\circ\text{C}$ , $U_D=12\text{V}$
Circuit commutated turn-off time (typical)	$t_q$	$\mu\text{s}$	$T_j=125^\circ\text{C}$ , $I_{TM}=250\text{A}$ , $di_R/dt=25\text{A}/\mu\text{s}$ , $du/dt=20\text{V}/\mu\text{s}$ , $U_D=0,67U_{DRM}$ , $U_{RM}=100\text{V}$
Turn-On time (typical)	$t_{on}$	$\mu\text{s}$	$I_{TM}=100\text{A}$ , $U_{DM}=100\text{V}$
Rate of rise of on-state current-repetitive	$di/dt$	$\text{A}/\mu\text{s}$	$T_j=125^\circ\text{C}$ , $I_{TM}=3I_{T(AV)}$ , $U_D=0,67U_{DRM}$ , $f=50\text{Hz}$ , $I_{GM}=1\text{A}$ , $di_G/dt=1\text{A}/\mu\text{s}$
Critical rate of raise of off-state voltage	$du/dt$	$\text{V}/\mu\text{s}$	$T_j=125^\circ\text{C}$ , $U_D=0,67U_{DRM}$ ,
Gate current to trigger	$I_{GT}$	mA	$T_j=25^\circ\text{C}$ , $U_D=12\text{V}$
Gate voltage to trigger	$U_{GT}$	V	$T_j=25^\circ\text{C}$ , $U_D=12\text{V}$

### Thermal properties

Parameter	Unit	Test conditions	Value
Thermal resistance, junction to case	$R_{thJC}$	°C/W	two sided, DC
Thermal resistance, case to heatsink	$R_{thCS}$	°C/W	two sided
Operating junction temperature	$T_{jmin} \dots T_{jmax}$	°C	-40...+125
Storage temperature	$T_{stg}$	°C	-40...+125

### Mechanical properties

Parameter	Unit	Value
Clamping force	$F_M$	kN
Weight	m	g

Zakłady Elektronowe LAMINA S.A.  
Puławska 34  
PL-05-500 Piaseczno  
POLAND

Tel.: +48-22-7572731  
Tel.: +48-22-3989409  
Fax.: +48-22-3989407  
e-mail: sekretariat@lamina.com.pl  
www.lamina.com.pl

# T95-1600

## Phase Control Thyristor

KKT951600, November 2006 version

### Package details

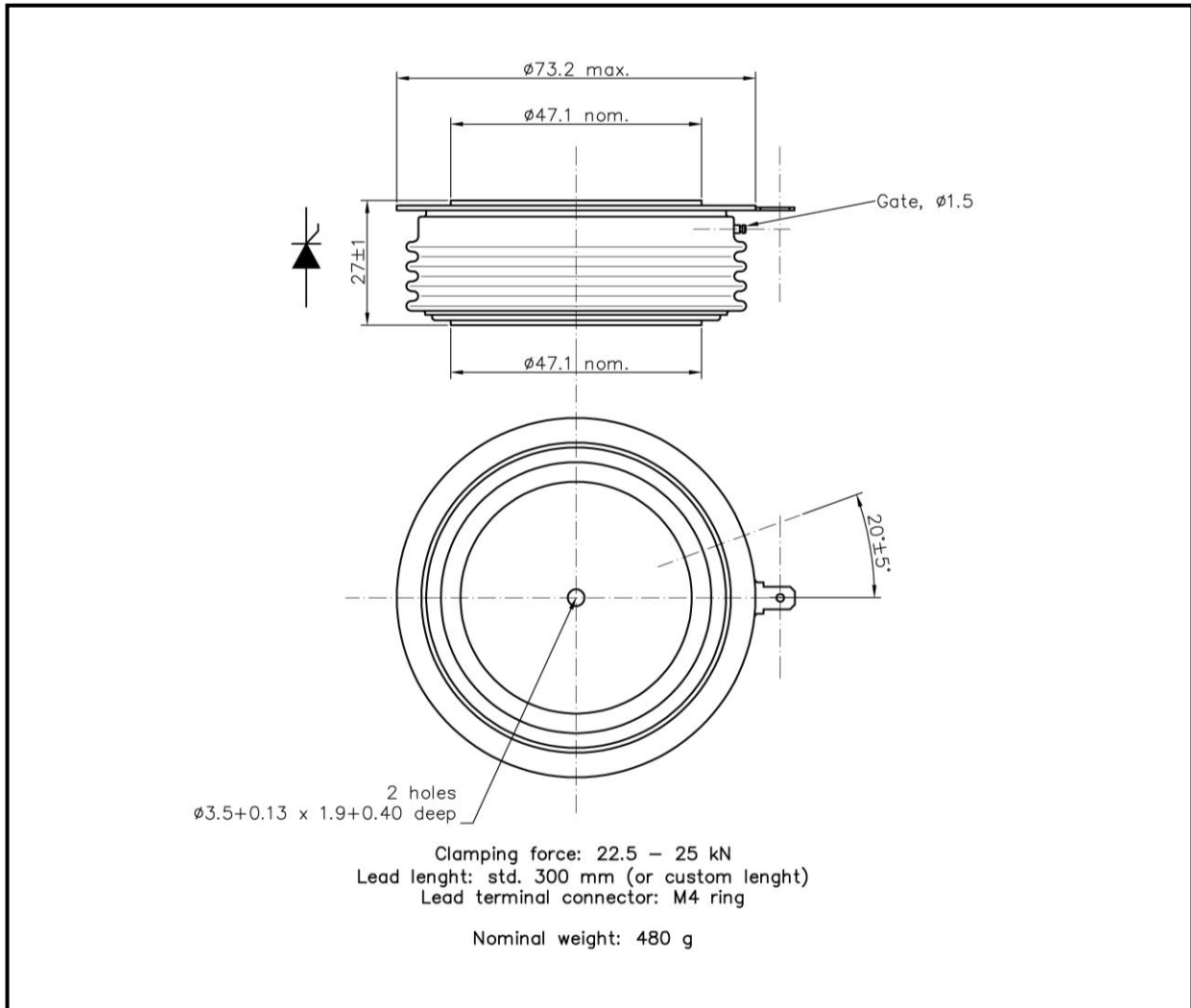

For further package information, please contact Sales & Marketing Department. All dimensions in mm, unless stated otherwise.  
Do not scale.

# T95-1600

## Phase Control Thyristor



KKT951600, November 2006 version

### CHARACTERISTICS

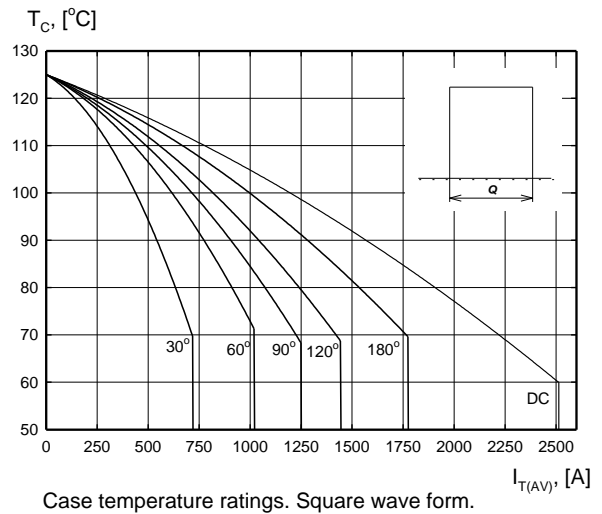
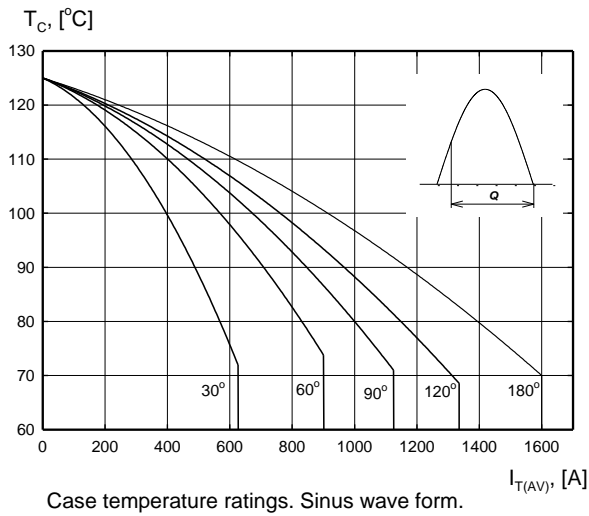
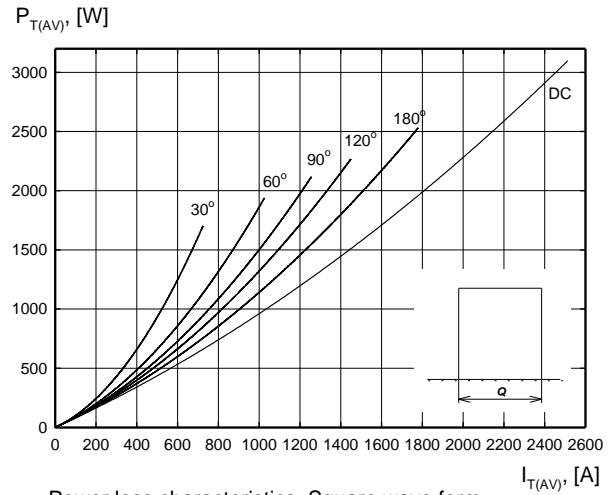
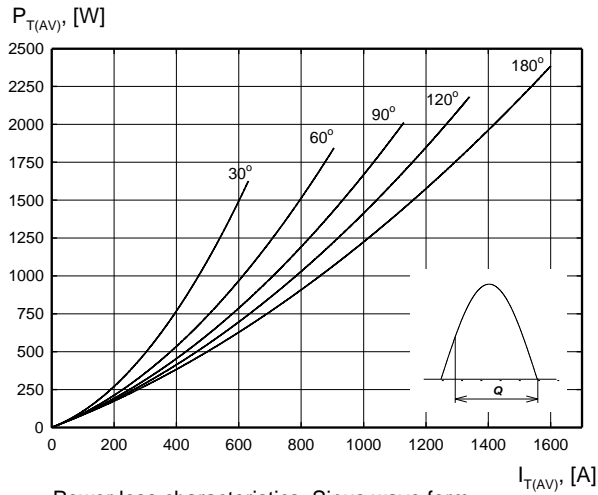

Zakłady Elektronowe LAMINA S.A.  
 Puławska 34  
 PL-05-500 Piaseczno  
 POLAND

Tel.: +48-22-7572731  
 Tel.: +48-22-3989409  
 Fax.: +48-22-3989407  
 e-mail: sekretariat@lamina.com.pl  
 www.lamina.com.pl

# T95-1600

## Phase Control Thyristor

KKT951600, November 2006 version

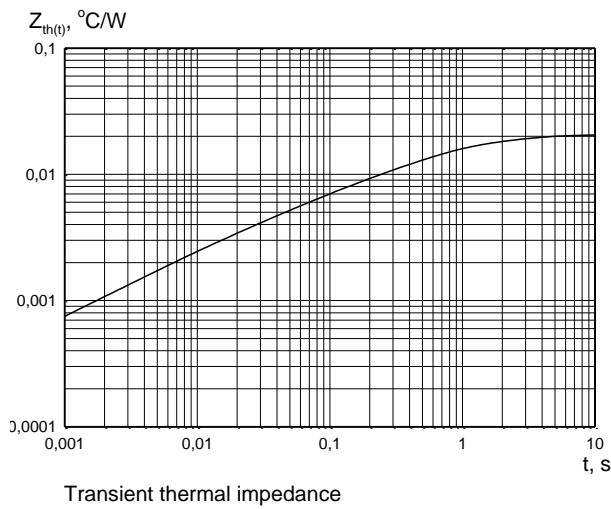
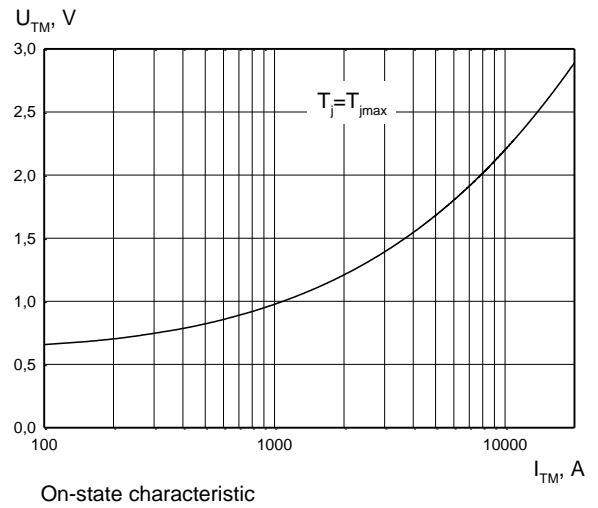
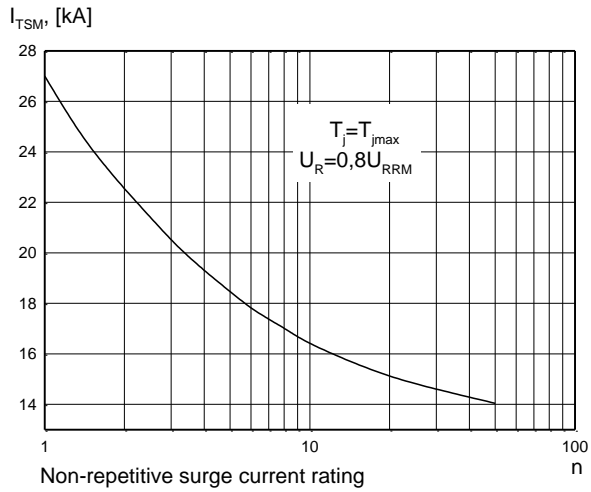

Zakłady Elektroniczne LAMINA S.A.  
Puławska 34  
PL-05-500 Piaseczno  
POLAND

Tel.: +48-22-7572731  
Tel.: +48-22-3989409  
Fax.: +48-22-3989407  
e-mail: sekretariat@lamina.com.pl  
www.lamina.com.pl

# T95-1600

## Phase Control Thyristor

KKT951600, November 2006 version

### Gate characteristics

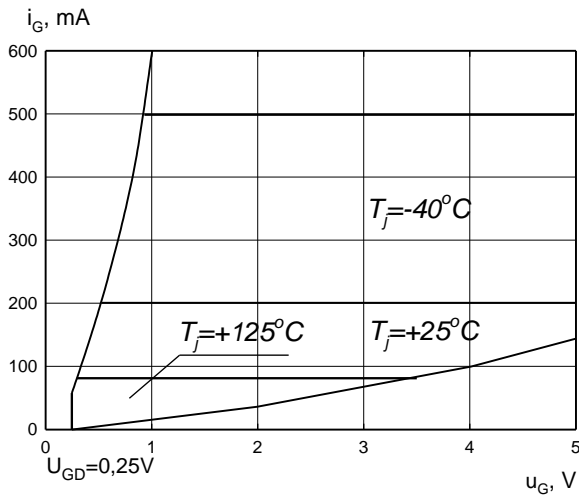

Gate characteristic. Possible trigger area.

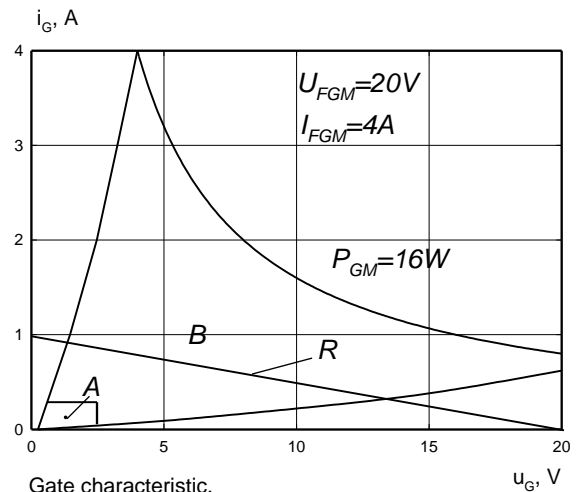

Gate characteristic.

A - possible trigger area  
B - permitted gate pulse forcing area  
R - recommended gate drive load line

## HEATSINKS

LAMINA S.I. has its own proprietary range of extruded aluminium heatsinks designed to optimise the performance of our semiconductors with natural and forced air flow. High efficiency water cooled copper heatsinks are also available.

## DEVICE CLAMPS

Disc devices require the correct clamping force to ensure their best operation. LAMINA S.I. offers a wide selection of clamps to suit all of our manufactured devices.

## POWER ASSEMBLY CAPABILITY

LAMINA S.I. provides a support for those customers requiring more than a basic semiconductor and offers precisely assembled Power Blocks according to factory or customer standards.

## X-ON Electronics

Largest Supplier of Electrical and Electronic Components

*Click to view similar products for [SCRs category](#):*

*Click to view products by [KUBARA LAMINA manufacturer](#):*

Other Similar products are found below :

[NTE5428](#) [NTE5448](#) [NTE5457](#) [NTE5511](#) [T1500N16TOF VT](#) [T720N18TOF](#) [T880N14TOF](#) [T880N16TOF](#) [TN1205H-6G](#) [TN1215-800B-TR](#)  
[TS110-7UF](#) [TT104N12KOF-A](#) [TT104N12KOF-K](#) [TT162N16KOF-A](#) [TT162N16KOF-K](#) [TT330N16AOF](#) [VS-111RKI120PBF](#) [VS-16RIA100](#)  
[VS-22RIA20](#) [VS-2N5206](#) [VS-2N685](#) [VS-40TPS08A-M3](#) [VS-50RIA10](#) [057219R](#) [T1190N16TOF VT](#) [T1220N22TOF VT](#) [T201N70TOH](#)  
[T830N14TOF](#) [T830N18TOF](#) [TD92N16KOF-A](#) [TT250N12KOF-K](#) [VS-ST180S12P0V](#) [VS-25RIA40](#) [VS-16RIA120](#) [VS-30TPS08PBF](#)  
[TN1215-800G-TR](#) [NTE5427](#) [NTE5442](#) [X0405NF 1AA2](#) [VS-ST300S20P0PBF](#) [T2160N28TOF VT](#) [TT251N16KOF-K](#) [VS-22RIA100](#) [VS-](#)  
[16RIA40](#) [CR02AM-8#F00](#) [VS-ST110S12P0VPBF](#) [TD250N16KOF-A](#) [GA301A](#) [VS-ST110S16P0](#) [VS-10RIA10](#)