



**Model Number**

**UB4000-30GM-E4-V15**

Single head system

**Features**

- **Switch output**
- **5 different output functions can be set**
- **Program input**
- **Synchronization options**
- **Deactivation option**
- **Temperature compensation**
- **Insensitive to compressed air**

**Diagrams**

**Characteristic response curve**

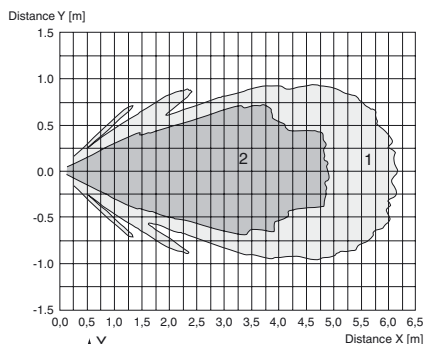

Curve 1: flat surface 100 mm x 100 mm  
Curve 2: round bar, Ø 25 mm

**Technical data**

**General specifications**

Sensing range	200 ... 4000 mm
Adjustment range	240 ... 4000 mm
Unusable area	0 ... 200 mm
Standard target plate	100 mm x 100 mm
Transducer frequency	approx. 85 kHz
Response delay	approx. 325 ms

**Indicators/operating means**

LED green	solid: Power-on flashing: program function object detected
LED yellow	solid: switching state switch output flashing: program function
LED red	normal operation: "fault" program function: no object detected

**Electrical specifications**

Operating voltage $U_B$	10 ... 30 V DC , ripple 10 % <sub>SS</sub>
No-load supply current $I_0$	≤ 50 mA

**Input/Output**

Synchronization	bi-directional 0 level: $-U_B \dots +1$ V 1 level: $+4$ V $\dots +U_B$ input impedance: > 12 KOhm synchronization pulse: ≥ 100 μs, synchronization interpulse period: ≥ 2 ms
-----------------	--

Synchronization frequency	Common mode operation ≤ 13 Hz Multiplex operation ≤ 13/n Hz, n = number of sensors
---------------------------	---

**Input**

Input type	1 program input, operating range 1: $-U_B \dots +1$ V, operating range 2: $+4$ V $\dots +U_B$ input impedance: > 4.7 kΩ; program pulse: ≥ 1 s
------------	--

**Output**

Output type	1 switch output NPN , Normally open/closed , programmable
Rated operational current $I_B$	200 mA , short-circuit/overload protected
Voltage drop $U_d$	≤ 2.5 V
Repeat accuracy	≤ 0.5 % of switching point
Switching frequency f	≤ 1.5 Hz
Range hysteresis H	1 % of the set operating distance
Temperature influence	< 2 % of far switch point

**Ambient conditions**

Ambient temperature	-25 ... 70 °C (-13 ... 158 °F)
Storage temperature	-40 ... 85 °C (-40 ... 185 °F)

**Mechanical specifications**

Connection type	Device connector M12 x 1 , 5-pin
Protection degree	IP65
Material	Housing: nickel plated brass; plastic components: PBT Transducer: epoxy resin/hollow glass sphere mixture; polyurethane foam Mass: 180 g

**Compliance with standards and directives**

Standard conformity	Standards: EN 60947-5-2:2007, IEC 60947-5-2:2007
---------------------	--

**Approvals and certificates**

UL approval	cULus Listed, General Purpose
CSA approval	cCSAus Listed, General Purpose

Release date: 2011-08-15 14:56 Date of issue: 2011-08-15 09:7970\_eng.xml

**Dimensions**

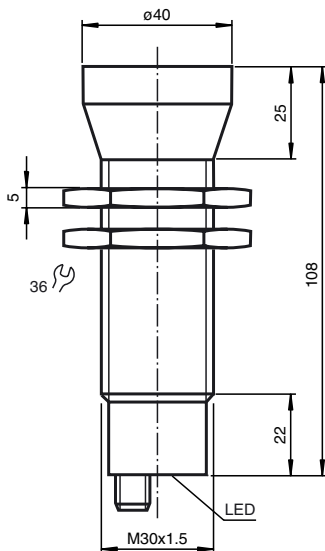

**Electrical Connection**

Standard symbol/Connections:  
(version E4, npn)

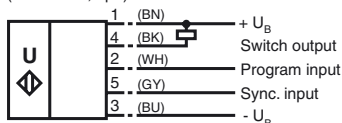

Wire colors in accordance with EN 60947-5-2.

**Pinout**

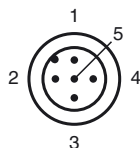

Wire colors in accordance with EN 60947-5-2

1	BN	(brown)
2	WH	(white)
3	BU	(blue)
4	BK	(black)
5	GY	(gray)

**Description of Sensor Functions**

**Programming procedure**

The sensor features a programmable switch output with two programmable switch points. Programming the switch points and the operating mode is done by applying the supply voltage  $-U_B$  or  $+U_B$  to the Program input. The supply voltage must be applied to the Program input for at least 1 s. LEDs indicate whether the sensor has recognized the

**Additional Information**

**Programmable output modes**

- Window mode, normally open mode  
A1 < A2:
- Window mode, normally closed mode  
A2 < A1:
- One switch point, normally open mode  
A1 -> ∞:
- One switch point, normally closed mode  
A2 -> ∞:
- A1 -> ∞, A2 -> ∞: Object presence detection mode  
Object detected: Switch output closed  
No object detected: Switch output open

**Accessories**

- BF 30**  
Mounting flange, 30 mm
- BF 5-30**  
Universal mounting bracket for cylindrical sensors with a diameter of 5 ... 30 mm
- UB-PROG2**  
Programming unit
- V15-G-2M-PVC**  
Cable socket, M12, 5-pin, PVC cable
- V15-W-2M-PUR**  
Cable socket, M12, 5-pin, PUR cable

target during the programming procedure.

**Note:**

If a programming adapter UB-PROG2 is used for the programming procedure, button A1 is assigned to  $-U_B$  and button A2 is assigned to  $+U_B$ .

**Programming Switch Point Modes**

**Normally open (NO) output**

1. Place the target at the desired switch point position
2. Program the switch point by applying  $+U_B$  to the Program input (yellow and green LEDs flash)
3. Cover the sensor face with hand or remove all objects from sensing range
4. Apply  $-U_B$  to the Program input (red and yellow LEDs flash)

**Normally closed (NC) output**

1. Place the target at the desired switch point position
2. Program the switch point by applying  $-U_B$  to the Program input (yellow and green LEDs flash)
3. Cover the sensor face with hand or remove all objects from sensing range
4. Apply  $+U_B$  to the Program input (red and yellow LEDs flash)

**Programming Window Modes**

**Normally open (NO) output**

1. Place the target at the near end of the desired switch window
2. Program the switch point by applying  $-U_B$  to the Program input (yellow and green LEDs flash)
3. Place the target at the far end of the desired switch window
4. Apply  $+U_B$  to the Program input (yellow and green LEDs flash)

**Normally closed (NC) output**

1. Place the target at the near end of the desired switch window
2. Program the switch point by applying  $+U_B$  to the Program input (yellow and green LEDs flash)
3. Place the target at the far end of the desired switch window
4. Apply  $-U_B$  to the Program input (yellow and green LEDs flash)

**Programming Object Detection Mode**

1. Cover the sensor face with hand or remove all objects from sensing range
2. Apply  $-U_B$  to the Program input (red and yellow LEDs flash)
3. Apply  $+U_B$  to the Program input (red and yellow LEDs flash)

**Factory settings**

Operation mode = switch window mode, normally open (NO)

Near end of the switching window = end of unusable area (see technical data)

Far end of the switching window = nominal sensing range (see technical data)

**Display**

The sensor provides LEDs to indicate various conditions.

	Green LED	Red LED	Yellow LED
<b>During Normal operation</b>			
Proper operation	On	Off	Switching state
Interference (e.g. compressed air)	Off	Flashing	remains in previous state
<b>During sensor programming</b>			
Object detected	Flashing	Off	Off
No object detected	Flashing	Off	On
Object uncertain (programming invalid)	Off	Flashing	Off

**Synchronization**

This sensor features a synchronization input for suppressing ultrasonic mutual interference ("cross talk"). If this input is not connected, the sensor will operate using internally generated clock pulses. It can be synchronized by applying an external square wave. The pulse duration must be  $\geq 100 \mu s$ . Each falling edge of the synchronization pulse triggers transmission of a single ultrasonic pulse. If the synchronization signal remains low for  $\geq 1$  second, the sensor will revert to normal operating mode. Normal operating mode can also be activated by opening the signal connection to the synchronization input. (See note below)

If the synchronization input goes to a high level for  $> 1$  second, the sensor will switch to standby mode, indicated by the green LED. In this mode, the outputs will remain in the last valid output state.

**Note:**

If the option for synchronization is not used, the synchronization input has to be connected to ground (0 V) or the sensor must be operated via a V1 cordset (4-pin).

The synchronization function cannot be activated during programming mode and vice versa.

**The following synchronization modes are possible:**

1. Several sensors (max. number see technical data) can be synchronized together by interconnecting their respective synchronization inputs. In this case, each sensor alternately transmits ultrasonic pulses in a self multiplexing mode. No two sensors will transmit pulses at the same time. (See note below)
2. Multiple sensors can be controlled by the same external synchronization signal. In this mode the sensors are triggered in parallel and are synchronized by a common external synchronization pulse.
3. A separate synchronization pulse can be sent to each individual sensor. In this mode the sensors operate in external multiplex mode. (See note below)
4. A high level ( $+U_B$ ) on the synchronization input switches the sensor to standby mode.

**Note:**

Sensor response times will increase proportionally to the number of sensors that are in the synchronization string. This is a result of the multiplexing of the ultrasonic transmit and receive signal and the resulting increase in the measurement cycle time.

**Installation conditions**

If the sensor is installed in an environment where the temperature can fall below  $0^\circ C$ , one of these mounting flanges must be used for mounting: BF30, BF30-F, or BF 5-30. If the sensor is mounted in a through hole using the included steel nuts, it must be mounted at the middle of the threaded housing. If it must be mounted at the front end of the threaded housing, plastic nuts with centering ring (optional accessories) must be used.

Release date: 2011-08-15 14:56 Date of issue: 2011-08-15 09:37:0\_eng.xml

## X-ON Electronics

Largest Supplier of Electrical and Electronic Components

*Click to view similar products for [Proximity Sensors](#) category:*

*Click to view products by [Pepperl & Fuchs](#) manufacturer:*

Other Similar products are found below :

[01.001.5653.1](#) [70.340.1028.0](#) [70.360.2428.0](#) [70.364.4828.0](#) [70.810.1053.0](#) [72.360.1628.0](#) [73.363.6428.0](#) [980659-1](#) [QT-12](#)  
[E2ECQC2D1M1GJT03M](#) [E2EX10D1NN](#) [E2E-X14MD1-G](#) [E2E-X2D1-G](#) [E2EX2ME2N](#) [E2E-X3D1-N](#) [10M](#) [E2E-X4MD1-G](#)  
[E2FMX1R5D12M](#) [E2K-F10MC1](#) [5M](#) [EC3016PPASL-1](#) [EI1204TBOSL-6](#) [EI5515NPAP](#) [BSA-08-25-08](#) [IC08ANC15PO-K](#) [25.161.3253.0](#)  
[25.332.0653.1](#) [25.352.0653.0](#) [25.352.0753.0](#) [25.523.3253.0](#) [922FS1.5C-A4P-Z774](#) [SC606ABV0S30](#) [SM552A100](#) [SM952A126100LE](#)  
[SM956A132600](#) [A1220EUA-T](#) [F3S-A162-U](#) [CL18](#) [QT-08L](#) [34.110.0010.0](#) [TL-C2MF1-M3-E4](#) [IA08BLF15NOM5](#) [IA08BSF15NOM5](#)  
[IA12ASF04DOM1](#) [IS2](#) [IS31SE5000-UTLS2-TR](#) [34.110.0021.0](#) [34.110.0022.0](#) [CA150-120VACDC](#) [VM18VA3000Q](#) [XS508BSCBL2](#)  
[XS512BLNAM12](#)