



Order Code

UC6000-30GM-IUR2-V15

Features

- Parameterisation interface for the application-specific adjustment of the sensor setting via the service program ULTRA 3000
- Current and voltage output
- Synchronisation options
- Adjustable acoustic power and sensitivity
- Temperature compensation

Electrical Connection

Standard symbol/Connection:
(version IU)

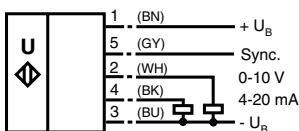

Core colours in accordance with EN 60947-5-2.

Connector V15



Dimensions

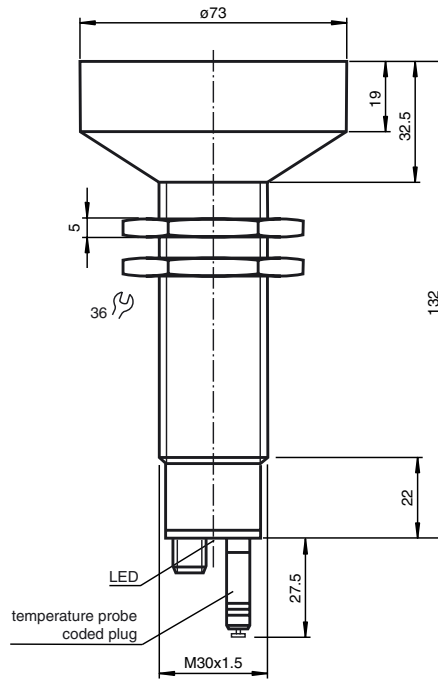

Technical Data

General specifications

Sensing range	350 ... 6000 mm
Adjustment range	400 ... 6000 mm
Unusable area	0 ... 350 mm
Standard target plate	100 mm x 100 mm
Transducer frequency	approx. 65 kHz
Response delay	285 ms minimum 850 ms factory setting

Indicators/operating means

LED green	permanent: Power-on flashing: Standby mode or TEACH-IN function object detected
LED yellow 1	permanent: object in evaluation range flashing: TEACH-IN function
LED yellow 2	permanent: object in detection range flashing: TEACH-IN function
LED red	permanent: temperature/TEACH-IN plug not connected flashing: fault or TEACH-IN function object not detected
Temperature/TEACH-IN connector	temperature compensation, TEACH-IN for evaluation range, output function setting

Electrical specifications

Operating voltage	10 ... 30 V DC, ripple 10 % _{SS}
Power consumption P ₀	≤ 900 mW

Interface

Interface type	RS 232, 9600 Bit/s, no parity, 8 data bits, 1 stop bit
----------------	--

Input/output

Synchronisation	bi-directional 0 level: -U _B ...+1 V 1 level: +4 V...+U _B input impedance: > 12 KOhm synchronisation pulse: ≥ 100 µs, synchronisation interpulse period: ≥ 2 ms
-----------------	---

Synchronisation frequency	≤ 7 Hz
Common mode operation	≤ 7 Hz
Multiplex operation	≤ 7/n Hz, n = number of sensors

Output

Output type	1 current output 4 ... 20 mA 1 voltage output 0 ... 10 V evaluation range [mm]/4000, but ≥ 0.35 mm
-------------	--

Resolution	≤ 0.2 % of full-scale value
Deviation of the characteristic curve	≤ 0.1 % of full-scale value
Repeat accuracy	≤ 0.1 % of full-scale value
Load impedance	current output: ≤ 500 Ohm Voltage output: ≥ 1000 Ohm
Temperature influence	≤ 2 % from full-scale value (with temperature compensation) ≤ 0.2 %/K (without temperature compensation)

Standard conformity

Standards	EN 60947-5-2
-----------	--------------

Ambient conditions

Ambient temperature	-25 ... 70 °C (248 ... 343 K)
Storage temperature	-40 ... 85 °C (233 ... 358 K)

Mechanical specifications

Protection degree	IP65
Connection	connector V15 (M12 x 1), 5 pin
Material	stainless steel 1.4303 plastic parts PBT
Housing	epoxy resin/hollow glass sphere mixture; polyurethane foam
Transducer	280 g
Mass	

Release date: 2008-03-26 09:20 Issue date: 2008-03-26 10:4095_ENG.xml

Description of the sensor functions

This ultrasonic sensor features a four-pole temperature/programming plug, that can be connected in four different positions. These have the following significance.

Plug position	Meaning
A1	Programming of evaluation limit A1
A2	Programming of evaluation limit A2
E2/E3	Rising/falling ramp/output characteristic of the voltage output by zero point
T	Temperature compensation

Description of the programming procedure

Programming the evaluation limits 1 or 2

- Disconnect supply voltage
- Remove the programming plug to activate the programming mode
- Reconnect supply voltage
- Place the target at the desired position (A1 or A2)
- Momentarily insert the programming plug in the desired position for configuring the evaluation limit A1 or A2, and then remove. This will program the selected evaluation limit.
- Caution:** Removing the programming plug, saves the new evaluation limit into the device memory.
- The programming status is indicated by the LED. A flashing green LED indicates that the target is detected. A flashing red LED indicates, that no target is detected.
- Insert the programming plug in position T. This completes the programming procedure and saves the distance.
- The sensor will now operate in normal mode

Programming the analogue function

- Disconnect supply voltage
- Remove the programming plug to activate the programming mode
- Reconnect supply voltage
- Insert the programming plug in position E2/E3. Now by removing and re-inserting the plug, you can toggle through three different modes of operation. The selected mode is indicated by the LEDs as shown below:
 - 1) Rising ramp, LED A2 flashes,
 - 2) Falling ramp, LED A1 flashes,
 - 3) Zero line, LED A1 and A2 flash
- Once the desired mode is selected, insert the programming plug in position T. This completes the programming procedure and saves the selected mode of operation.
- The sensor now operates in normal mode

Note: The programming plug also functions as the temperature compensation sensor. If the programming plug has not been inserted in the T position within 5 minutes, the sensor will return to normal operating mode with the latest saved values without temperature compensation.

Synchronisation

The sensor features a synchronisation input for the possible suppression of ultrasonic mutual interference. If this input is not connected, the sensor will operate using internally generated clock pulses. It can be synchronised by applying an external square wave. The synchronisation pulse falling edge triggers each transmission of a single ultrasonic pulse. If the synchronisation signal remains low for > 1 second, the sensor will revert to non synchronised mode. Non synchronised mode can also be activated by opening the signal connection to the synchronisation input (see note below).

If the synchronisation input goes to a high level for > 1 second the sensor will switch to standby mode indicated by green LED. In this mode the outputs will remain in the last valid output state.

The synchronisation function cannot be activated during programming mode and vice versa.

The following synchronisation modes are possible:

1. Two to five sensors can be synchronised together by interconnecting their respective synchronisation inputs. In this case, each sensor alternately transmits ultrasonic pulses in a self multiplexing mode. No two sensors will transmit pulses at the same time.
2. Multiple sensors can be controlled by the same external synchronisation signal. In this mode the sensors are triggered in parallel and are synchronised by a common external synchronisation pulse. All synchronised sensors will transmit ultrasonic pulses at the same time.
3. A separate synchronisation pulse can be sent to each individual sensor. In this mode the sensors operate in external multiplex mode.
4. A high level on the synchronisation input disables the sensor.

Sensor response times will increase proportionally to the number of sensors that are in the synchronisation string. This is a result of the multiplexing of the ultrasonic transmit and receive signal and the resulting increase in the measurement cycle time.

Characteristic Curves/Additional Information

Characteristic response curve

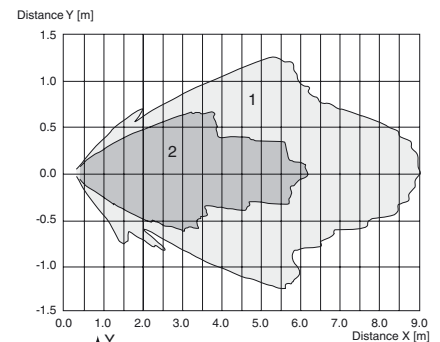

Curve 1: flat surface 100 mm x 100 mm
Curve 2: round bar, Ø 25 mm

Programmed analogue output function

Analogue function

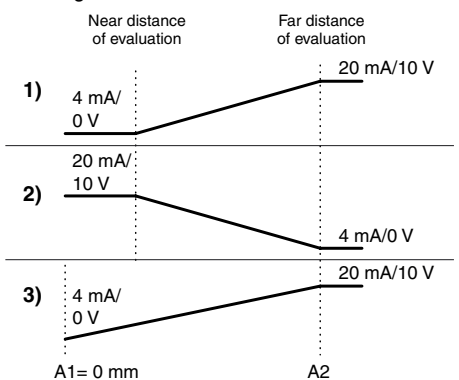

Accessories

- BF 30 Mounting flange
- BF 30-F Mounting flange
- UC-30GM-TEMP Accessories
- UC-30GM-PROG Accessories
- ULTRA3000 Software for ultrasonic sensors, comfort line
- UC-30GM-R2 Accessories
- DA5-IU-2K-V Process control and indication equipment
- V15-G-2M-PVC Cable connector
- V15-W-2M-PUR Cable connector

Release date: 2008-03-26 09:20 Issue date: 2008-03-26 10:40:55_ENG.xml

Note:

If the option for synchronisation is not used, the synchronisation input must be connected to ground (0V) or the sensor must be operated using a V1 cordset (4-pin).

Default setting

A1: unusable area
 A2: nominal sensing range
 Mode of operation: rising ramp

LED Displays/Analogue output

Displays in dependence on operating mode	Dual LED green	Dual-LED red	LED yellow A1	LED yellow A2	analogue output
TEACH-IN evaluation limit A1 object detected object not detected	flashing off	off flashing	flashing flashing	off off	unchanged
TEACH-IN evaluation limit A2 object detected object not detected	flashing off	off flashing	off off	flashing flashing	unchanged
TEACH-IN mode of operation (E2/E3) rising ramp falling ramp zero line	on on on	off off off	off flashing flashing (syn- chronised)	flashing off flashing (syn- chronised)	unchanged
Normal mode temperature compensated plug pulled/shorted	on off	off on	on, if target in evaluation range	on, if target in detection range	analogue value
Standby	flashing	off	previous state	previous state	unchanged
Interference (e.g. compressed air)	off	flashing	previous state	previous state	unchanged or error value

LED-Window

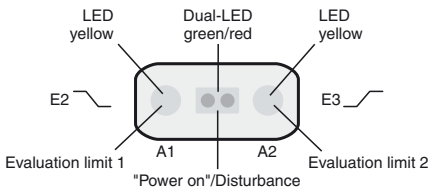

RS 232-connection

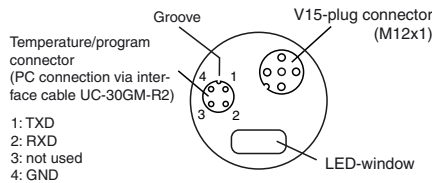

Note on communication with the UC-30GM-R2 interface cable

The UC-30GM-R2 interface cable allows for communication with the ultrasonic sensor using the ULTRA 3000 service program. The cable creates a connection between the PC-internal RS 232 interface and the plug-in connection for the temperature/program plug on the sensor. When setting up the connection on the sensor, make certain the plug is lined up correctly; otherwise no communication will be possible. The protrusion of the round plug must be inserted into the groove of the plug connection on the sensor side and **not** into the arrow symbol on the sensor.

Adjustable parameter with service program ULTRA 3000

- Evaluation limits A1 and A2
- Rising/falling ramp/zero line
- Mode of operation
- Sonic speed
- Temperature offset (The inherent temperature-rise of the sensor can be considered in the temperature compensation)
- Expansion of the unusable area (for suppression of unusable area echoes)
- Reduction of the detection range (for suppression of remote range echoes)
- Time of measuring cycle
- Acoustic power (interference of the burst duration)
- Sensitivity
- Behaviour of the sensor in case of echo loss
- Behaviour of the sensor in case of a fault
- Average formation via an allowed number of measuring cycles
- Selection of the parameter set, RS 232 or manually.

X-ON Electronics

Largest Supplier of Electrical and Electronic Components

Click to view similar products for [Proximity Sensors](#) category:

Click to view products by [Pepperl & Fuchs](#) manufacturer:

Other Similar products are found below :

[01.001.5653.1](#) [70.340.1028.0](#) [70.360.2428.0](#) [70.364.4828.0](#) [70.810.1053.0](#) [72.360.1628.0](#) [73.363.6428.0](#) [980659-1](#) [QT-12](#)
[E2ECQC2D1M1GJT03M](#) [E2EX10D1NN](#) [E2E-X14MD1-G](#) [E2E-X2D1-G](#) [E2EX2ME2N](#) [E2E-X3D1-N](#) [10M](#) [E2E-X4MD1-G](#)
[E2FMX1R5D12M](#) [E2K-F10MC1](#) [5M](#) [EC3016PPASL-1](#) [EI1204TBOSL-6](#) [EI5515NPAP](#) [BSA-08-25-08](#) [IC08ANC15PO-K](#) [25.161.3253.0](#)
[25.332.0653.1](#) [25.352.0653.0](#) [25.352.0753.0](#) [25.523.3253.0](#) [922FS1.5C-A4P-Z774](#) [SC606ABV0S30](#) [SM552A100](#) [SM952A126100LE](#)
[SM956A132600](#) [A1220EUA-T](#) [F3S-A162-U](#) [CL18](#) [QT-08L](#) [34.110.0010.0](#) [TL-C2MF1-M3-E4](#) [IA08BLF15NOM5](#) [IA08BSF15NOM5](#)
[IA12ASF04DOM1](#) [IS2](#) [IS31SE5000-UTLS2-TR](#) [34.110.0021.0](#) [34.110.0022.0](#) [CA150-120VACDC](#) [VM18VA3000Q](#) [XS508BSCBL2](#)
[XS512BLNAM12](#)